



Installation instructions

Akrapovič Exhaust System
Evolution and Racing Line
A607.05.999.000
A674.05.899.044



509416

EN
Revision 1.0 02/2026

www.akrapovic.com

Congratulations on purchasing the Akrapovič exhaust system. The Akrapovič exhaust system is a product of Akrapovič d.d., Malo Hudo 8a, 1295 Ivančna Gorica, Slovenia ("Akrapovič").

Please read this entire installation manual carefully prior to installing and using the Akrapovič exhaust system.

Akrapovič exhaust system should only be installed by persons skilled in motorcycle exhaust system installation and performance. The instructions provided in this manual should be followed to ensure proper installation and safe use of the Akrapovič exhaust system. Akrapovič and/or its partners shall not be held liable for any damage or personal injury (including direct, indirect, or consequential damage) sustained as a result of improper installation of the Akrapovič exhaust system or its use and maintenance contrary to the instructions and warnings contained herein.

If you have any questions regarding the installation and/or proper use of the Akrapovič exhaust system or this manual, please contact your local Akrapovič partner.

GENERAL INFORMATION

Your safety is our number one priority. Please ride your motorcycle responsibly, safely and always obey local traffic rules.

All statements made with regard to the exhaust system's compliance are made in respect of the exhaust system "as is". Any modifications of the Akrapovič exhaust system or its improper installation, use or maintenance that is not in accordance with this Installation manual, may result in severe damage to the exhaust system and/ or engine, as well as personal injury, and may affect the exhaust system's compliance with the legal requirements, such as exhaust system's air and/ or noise emissions (as an example, the motorcycle may not be suitable for use on public roads any longer).

The exhaust system may only be used in accordance with relevant laws and regulations, including state and federal, where applicable.

Technical specifications of Akrapovič exhaust systems and related products are subject to change without notice.

COPYRIGHT AND OTHER RIGHTS NOTICE

The Akrapovič trademark, including corporate logos and emblems, are subject to copyright as well as trademark rights of Akrapovič, its licensors, or third persons authorizing Akrapovič to use them.

Any reproduction, technical or other manipulation, translation, or other use of the copyright and/or trademark rights contained herein is prohibited without the explicit prior written consent of Akrapovič. The same especially applies to the entire contents of this manual and/or any of its parts, including but not limited to technical specifications, instructions, graphs, photographs, and so on included in this manual.

The shape of the exhaust system is protected under a registered Community Design No. RCD 002747246-001.

Akrapovič takes all copyright and other rights infringement cases under serious consideration. If you have any reason to believe that your exhaust system is not an original Akrapovič product, please contact our local partners or Akrapovič at info@akrapovic.com.

SAFETY AND COMPLIANCE WARNING, PLEASE READ CAREFULLY

BEFORE REMOVING THE STOCK EXHAUST SYSTEM AND BEGINNING THE INSTALLATION OF YOUR NEW AKRAPOVIČ EXHAUST, PLEASE MAKE SURE THAT ALL ITEMS LISTED BELOW ARE VERIFIED:

- THIS MANUAL IS SPECIFIC TO THE MOTORCYCLE INDICATED ON THE COVER PAGE, FOR WHICH IT IS DESIGNED. INSTALLATION PROCEDURES VARY DEPENDING ON THE TYPE OF MOTORCYCLE. PLEASE VERIFY THAT THE AKRAPOVIČ **EXHAUST SYSTEM AND THIS INSTALLATION MANUAL CORRESPOND TO THE TYPE OF YOUR MOTORCYCLE.**
- THE EXHAUST SYSTEM CAN GET EXTREMELY HOT DURING AND AFTER IT IS USED. MAKE SURE NOT TO TOUCH THE EXHAUST SYSTEM UNTIL IT IS COMPLETELY COOL. **ALLOW THE EXHAUST AND ENGINE TO COOL DOWN BEFORE BEGINNING INSTALLATION OR ANY OTHER WORK ON THE EXHAUST SYSTEM.**
- MAKE SURE THE MOTORCYCLE IS **SECURELY POSITIONED TO PREVENT TIPPING OVER** AND DAMAGE TO YOURSELF AND OTHERS, OR THE MOTORCYCLE.
- PLEASE MAKE SURE THAT YOU HAVE **ALL THE PARTS NECESSARY FOR THE INSTALLATION** OF YOUR NEW AKRAPOVIČ EXHAUST SYSTEM, SEE PARTS LIST ON PAGE 5. IF ANY OF THE PARTS IS MISSING, PLEASE DO NOT PROCEED WITH UNINSTALLING YOUR STOCK EXHAUST SYSTEM/ INSTALLING THE AKRAPOVIČ EXHAUST SYSTEM AND CONTACT THE RETAILER WHERE YOU PURCHASED THE AKRAPOVIČ EXHAUST SYSTEM.
- ALWAYS **SECURE YOUR MOTORCYCLE'S GROUND CLEARANCE.** FOR ADVANCED USERS, WE RECOMMEND YOU CHECK THE MOTORCYCLE SPRING PRELOAD SETTINGS TO OPTIMIZE GROUND CLEARANCE WHERE POSSIBLE.
- EVERY EXHAUST SYSTEM MUFFLER HAS ITS UNIQUE SERIAL NUMBER, WHICH IDENTIFIES THE AUTHENTICITY OF THE PRODUCT. YOU CAN FIND THE SERIAL NUMBER ON THE MUFFLER'S INLET PIPE. PLEASE REFER TO THE PICTURE BELOW. PLEASE VERIFY THAT YOUR EXHAUST SYSTEM IS AN ORIGINAL AKRAPOVIČ PRODUCT. IF YOU HAVE ANY DOUBTS, PLEASE CONTACT THE RESELLER WHERE YOU PURCHASED THE EXHAUST SYSTEM.

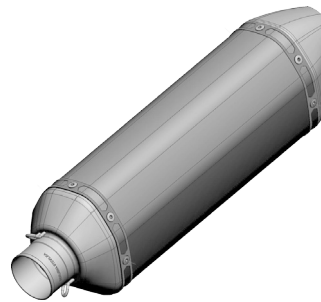
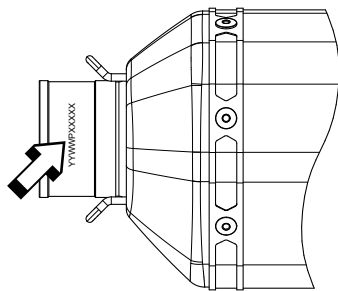

SERIAL NUMBER POSITION

NOISE AND EMISSION WARNINGS

General warning

Because of the world-wide distribution of Akrapovič d.d. products, neither Akrapovič d.d. nor any of its subsidiaries make any representation that the products comply with the air and/or noise emissions laws, or labeling laws, of any jurisdiction. The purchasers are entirely responsible for informing themselves of the applicable laws where the products are to be used and to comply with those law.

USA WARNING

Various U.S. states and the U.S. federal government have individual laws regulating the use of aftermarket exhaust parts and systems, especially as those parts and systems modify, remove, or replace original equipment catalysts. Please consult the appropriate laws in your area before installing any aftermarket part or system on your vehicle to ensure compliance with all applicable laws. Neither Akrapovic d.d. nor any of their subsidiaries or the sellers of the parts or systems make any representation that any of their parts or systems comply with any such laws.

CALIFORNIA WARNING

California laws prohibit the use of any aftermarket exhaust part or system that modifies, removes or replaces original equipment catalysts unless the California Air Resources Board has issued an Executive Order regarding such part or system or unless the part or system is exempted by being used only on racing vehicles on closed courses. Neither Akrapovic d.d. nor any of their subsidiaries make any representation that any of their parts or systems has received such an Executive Order or that any of their parts or systems conform with the racing vehicles exemption. The purchasers are entirely responsible for informing themselves of applicable California laws and to comply with those laws.

GENERAL NOTE

Photographs and other illustrations in this manual are symbolic and are intended to help represent individual steps for proper installation and use, as well as for a general overview. The actual component parts of the Akrapovič exhaust system may not entirely correspond to the photographs and other illustrations.

SYMBOLS

The following symbols are used throughout these installation instructions:



TOOLS AND PROTECTIVE EQUIPMENT REQUIRED



TIGHTENING TORQUE



LUBRICATION



HAND TIGHTEN



INSTALLATION TIP



CAUTION OR IMPORTANT

USE BOLT SEALANT



Apply 3 to 4 small drops of bolt sealant onto the cleaned and degreased threads before tightening the bolts.

WARNING! Avoid contact with skin, eyes and mucous membranes. Do not inhale fumes. Keep out of reach of children.

USE ANTI-SEIZE LEAD-FREE COPPER PASTE (black tube)



Provides trouble-free and long-lasting protection against seizing, corrosion and rusting of bolts, threaded ends, nuts, joints, etc. Also protects against vibration, wear and impact.

WARNING! Avoid eye contact. Keep out of reach of children.

USE ANTI-SEIZING GREASE (white tube)



Prevents seizing, corrosion and excessive wear between the titanium components of your exhaust system.

WARNING! Avoid eye contact. Keep out of reach of children.

Tools & equipment

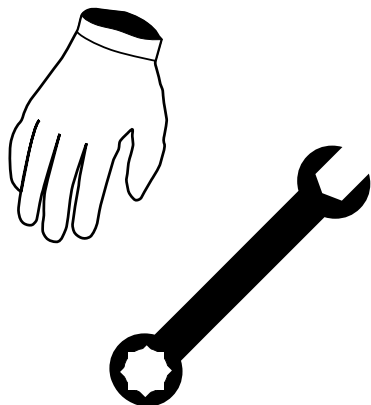

- Torx 25 wrench
- Torx 30 wrench
- Torx 40 wrench
- Torx 45 wrench
- Torx 50 wrench
- Combination 13 mm wrench
- Combination 22 mm wrench
- T- handle swivelling 10 mm wrench
- T- handle swivelling 13 mm wrench

PARTS LIST

The following parts should be found in the box:

- Installation Manual
- Homologation certificate/ compliance documents if applicable
- Fitting material
- Muffler and/or pipes
- Parts depicted on schematic view

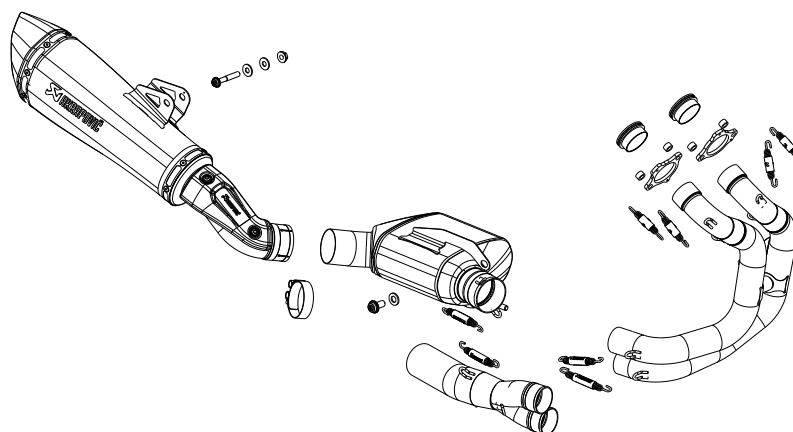

REMOVAL OF STOCK EXHAUST SYSTEM:

The process of uninstalling the original exhaust system may vary depending on the existing exhaust system. Please follow the original exhaust system manufacturer's instructions for uninstalling the original exhaust system.

If you for any reason decide otherwise, please note that any information provided in this respect herein should be considered as general information provided for your convenience only.

In case your Akrapovič exhaust system may not be used on certain roads or under certain conditions, please keep the stock or other exhaust system that you can use in such circumstances legally.

REMOVAL OF STOCK EXHAUST SYSTEM:

1. Put the motorcycle on a stand, we recommend a central racing stand. Make sure, that surface is solid and flat.
2. Unhook the marked springs and unscrew the marked muffler's bracket bolt then carefully remove the muffler off the motorcycle (F 01, 02).

! **CAUTION:** be careful not to injure yourself or damage any part of the motorcycle during this procedure!

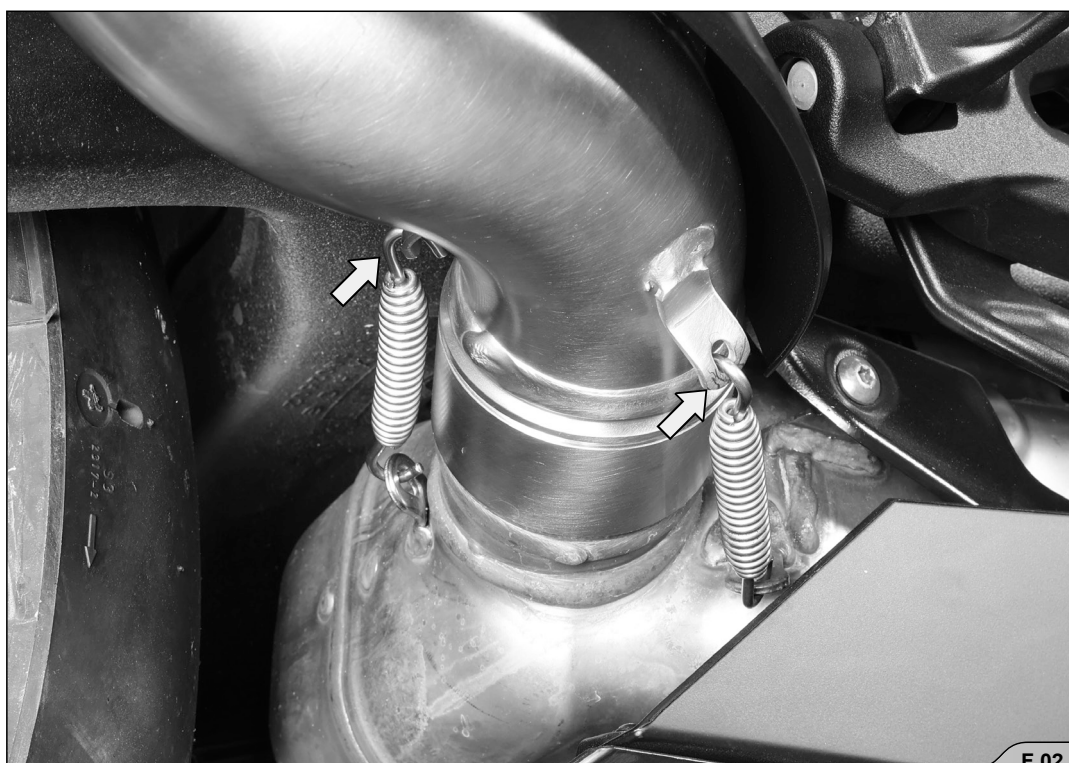

3. For KTM RC 990R model only; unscrew the marked bolts on both sides of the motorcycle and carefully remove the lower parts of the cowling off the motorcycle (F 03, 04, 05, 06).

! CAUTION: be careful not to injure yourself or damage any part of the motorcycle during this procedure!



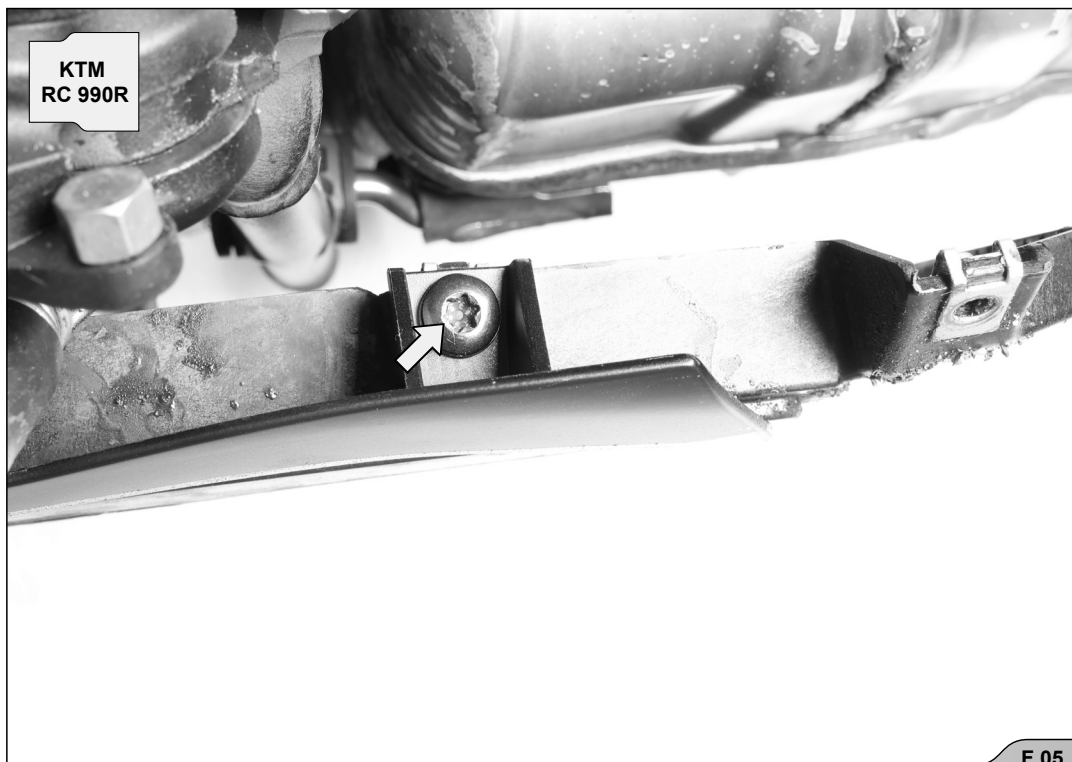

4. For KTM RC 990R model only; unscrew the marked bolts and remove plastic fasteners on both sides of the motorcycle (F 07, 08).

! CAUTION: be careful not to injure yourself or damage any part of the motorcycle during this procedure!



5. **For KTM RC 990R model only;** unscrew the marked bolt on both sides of the motorcycle and remove the plastic cover (F 09).

! CAUTION: be careful not to injure yourself or damage any part of the motorcycle during this procedure!



6. **For KTM RC 990R model only;** unscrew the marked bolts and remove plastic fasteners on both sides of the motorcycle and just partially remove the cowling off the motorcycle (F 10).

! CAUTION: be careful not to injure yourself or damage any part of the motorcycle during this procedure!

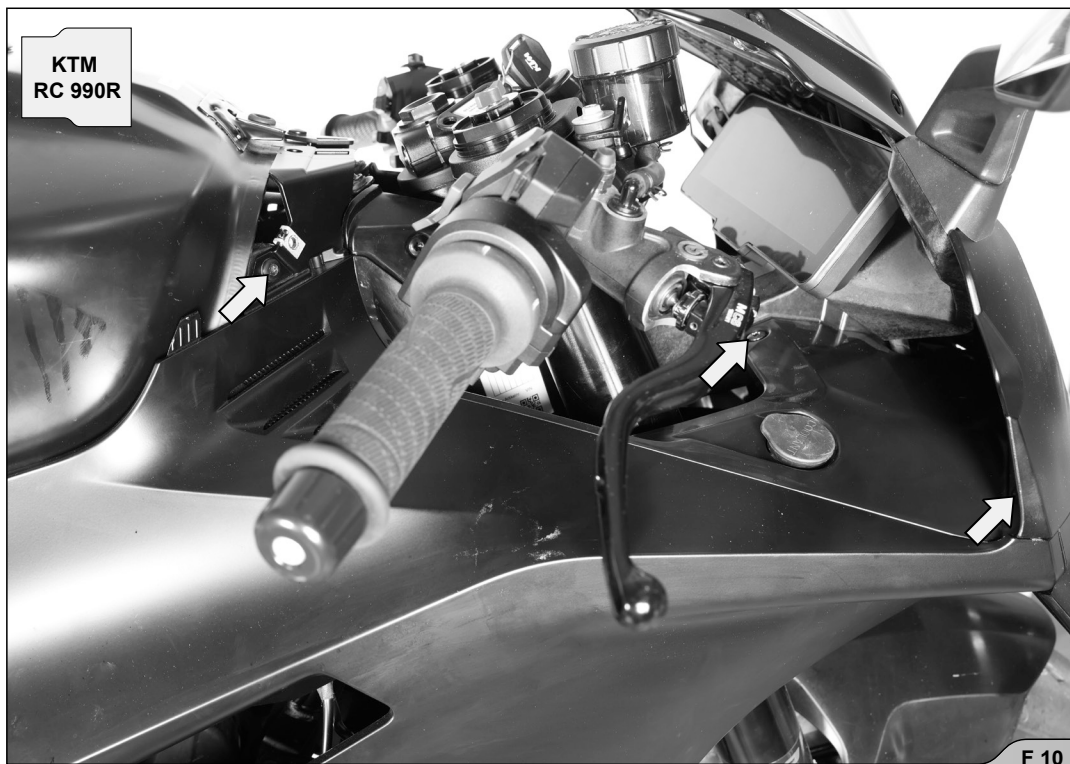



7. Loosen the marked bolt and partially remove the clamp off the joint (F 12).

! CAUTION: be careful not to injure yourself or damage any part of the motorcycle during this procedure!

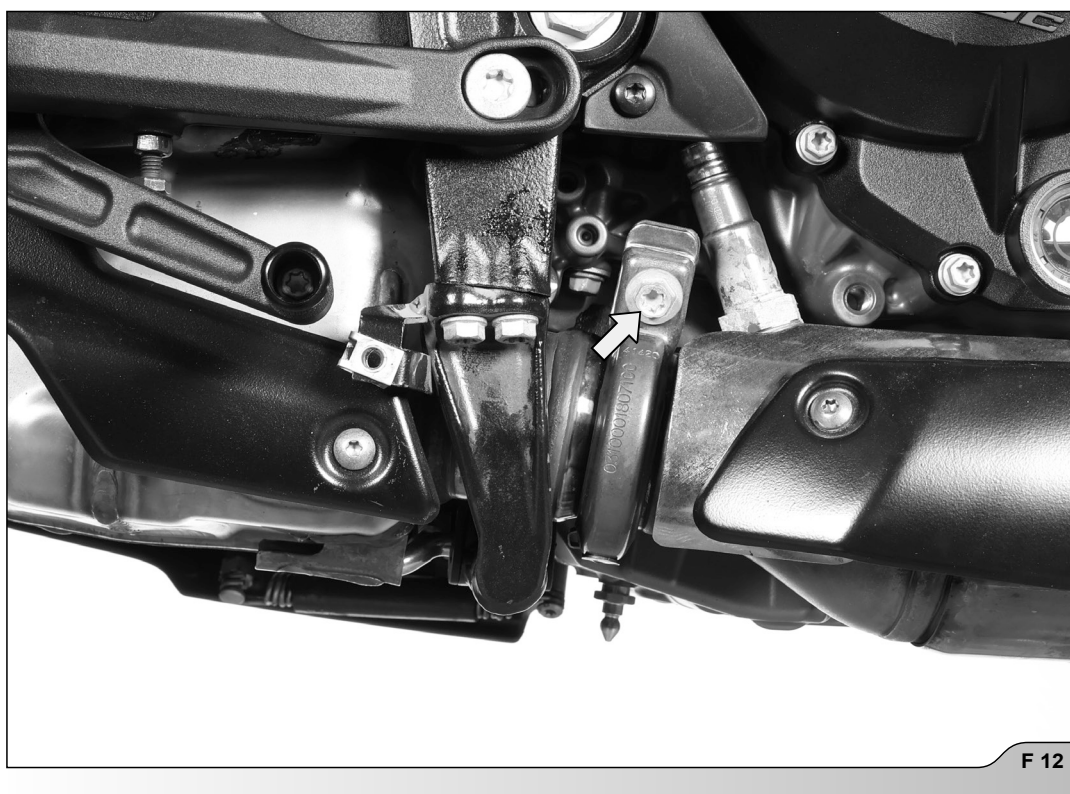

8. Unscrew marked bolts and remove the plastic cover off the motorcycle (F 13).

! **CAUTION:** be careful not to injure yourself or damage any part of the motorcycle during this procedure!



9. Unscrew the marked lambda sensor, unplug the lambda sensor connection, carefully undo the zip ties and remove the lambda sensor off the motorcycle (F 14, 15, 16, 17).

! **IMPORTANT:** make sure not to damage the lambda sensor's electrical lead during this process!

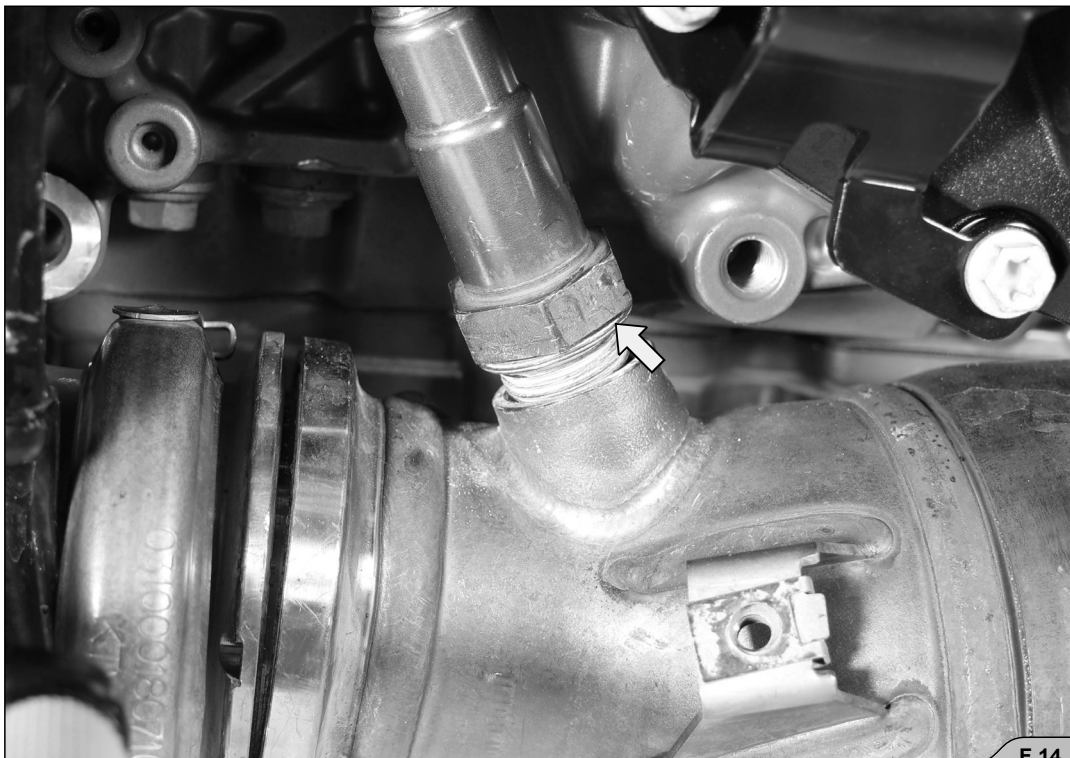

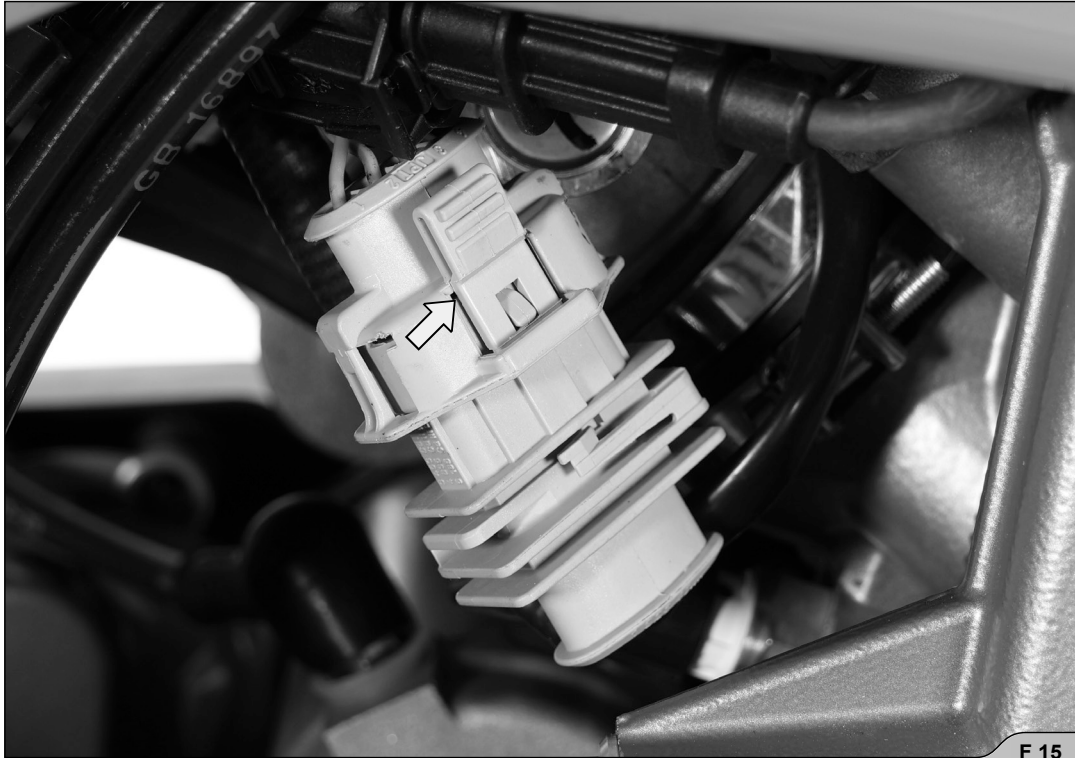

F 15



F 16



F 17

10. Mark and unscrew the lambda sensors out off the header pipes (F 18).

! IMPORTANT: make sure not to damage the lambda sensor's electrical lead during this process!

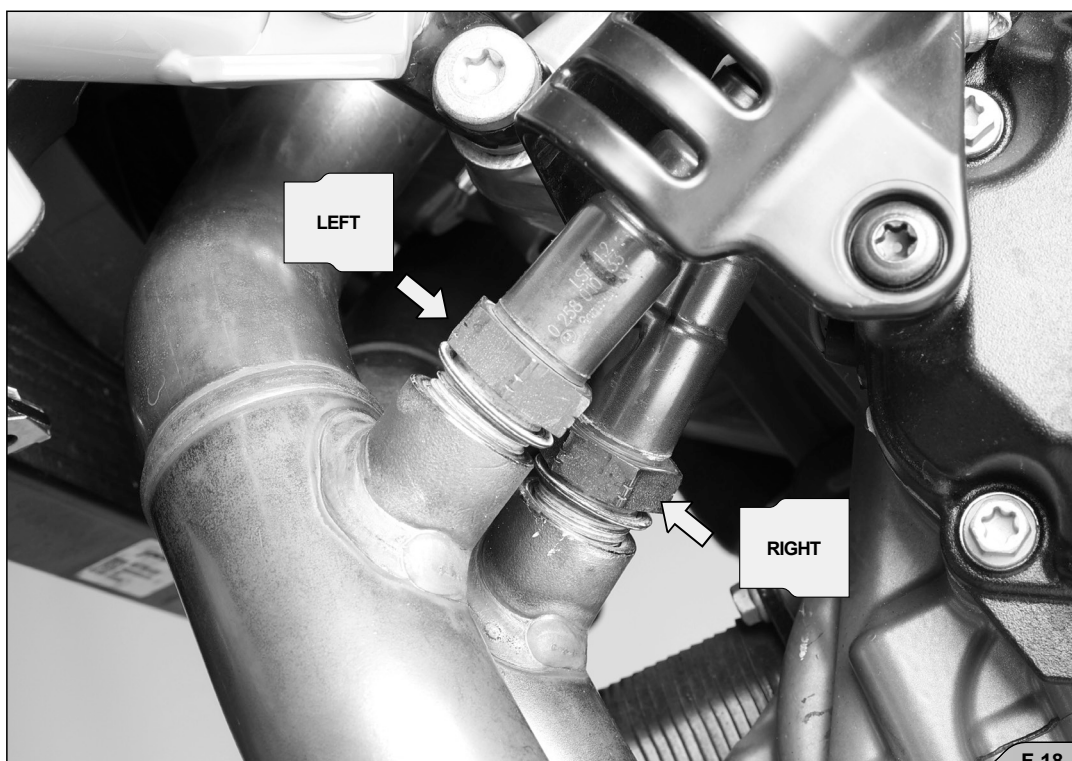

F 18

11. Unscrew the flange nuts, and carefully remove the headers off the motorcycle (F 19).

! **CAUTION:** be careful not to damage the radiator or any other part of the motorcycle during this process!

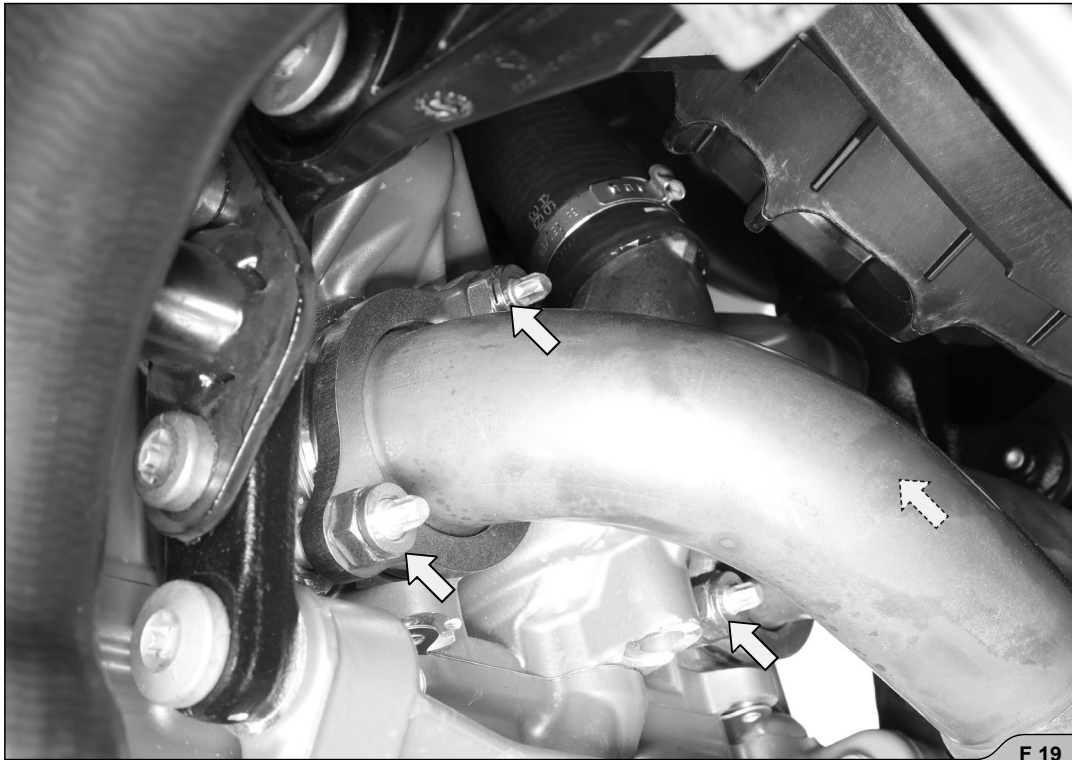

F 19

12. Unscrew the marked bolt, and partially remove the shift lever off the motorcycle (F 20).

! **CAUTION:** be careful not to injure yourself or damage any part of the motorcycle during this procedure!



F 20

13. Unscrew marked bolts and partially remove the bracket off the motorcycle (F 21, 22).

! **CAUTION:** be careful not to injure yourself or damage any part of the motorcycle during this procedure!

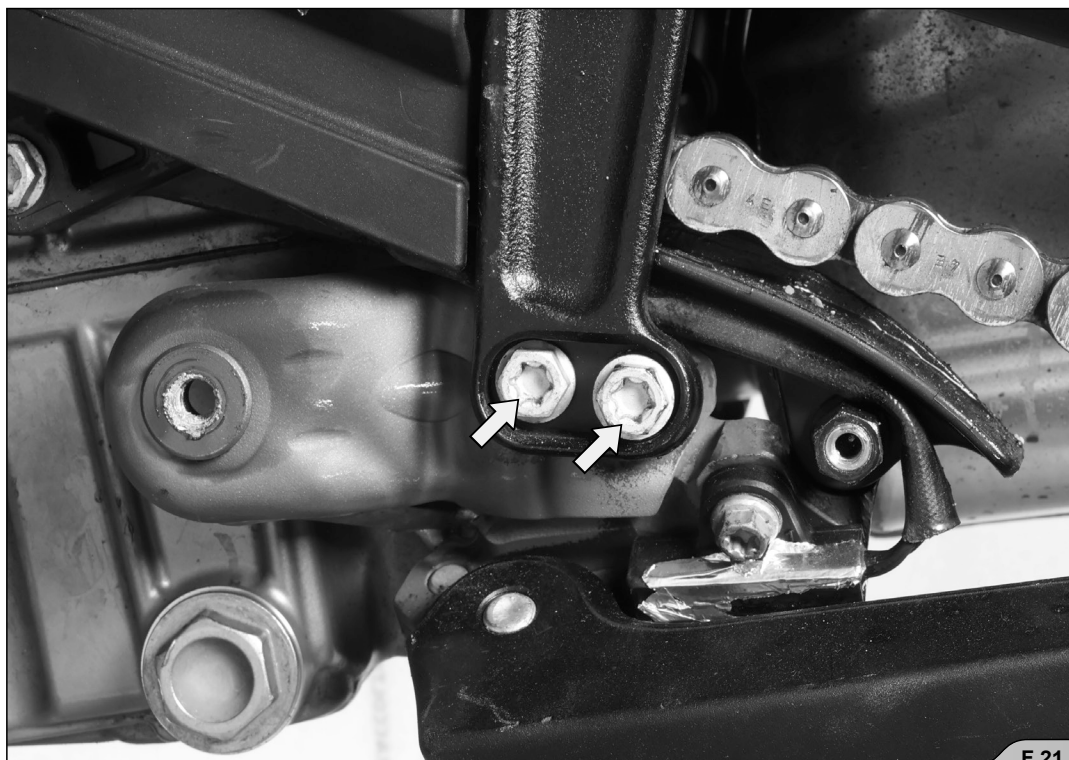

14. Unscrew marked bolts and remove the pre muffler off the motorcycle (F 23).

! **CAUTION:** be careful not to injure yourself or damage any part of the motorcycle during this procedure!



F 23

15. Carefully remove the clip on nuts off the motorcycle (F 24).

! **CAUTION:** be careful not to injure yourself or damage any part of the motorcycle during this procedure!

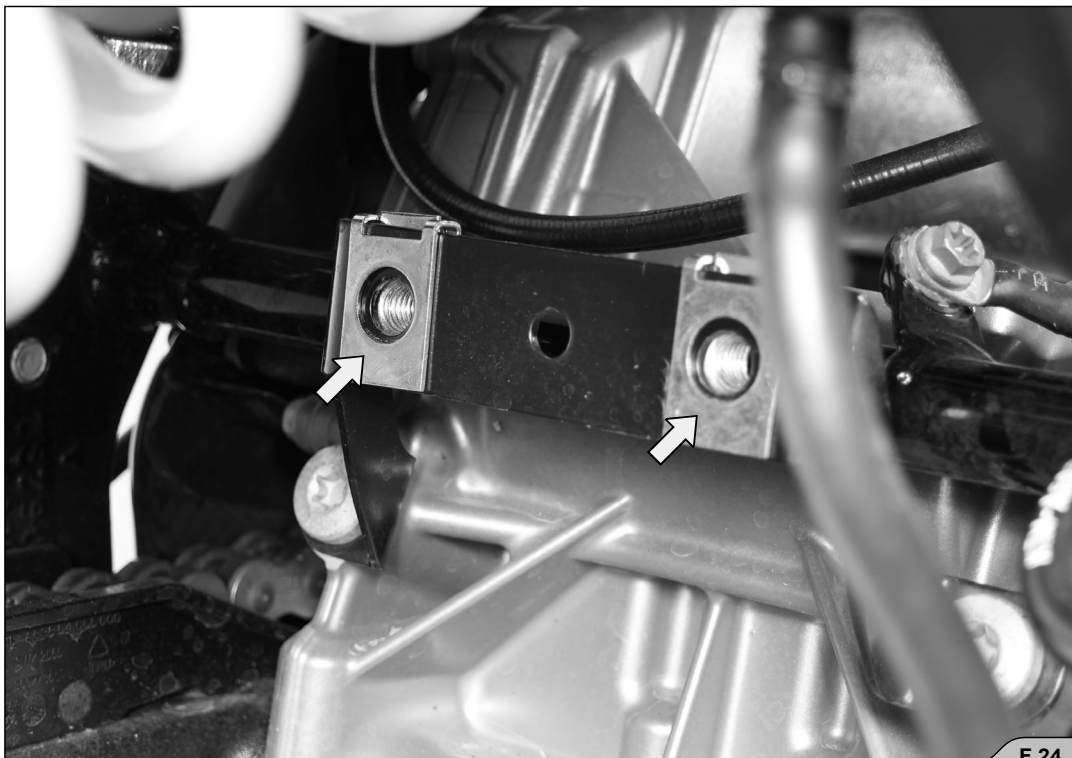

F 24

INSTALLATION OF THE AKRAPOVIČ EXHAUST SYSTEM:

1. Set up and hand tighten the flanges together with the sleeves and bushes onto the cylinder head, using stock nuts; bare in mind the right position of the engraved numbers (F 25, 26, 27).

! IMPORTANT: do not fully tighten the flanges yet!

✂ INSTALLATION TIP: use new stock exhaust port gaskets.

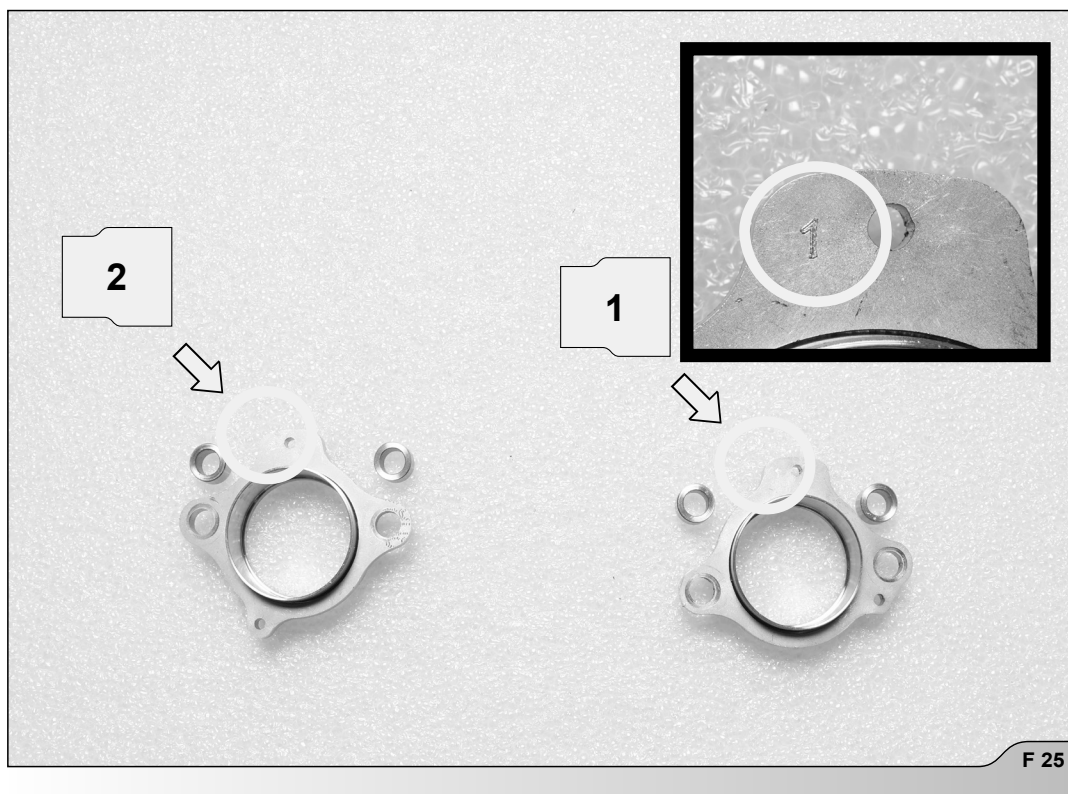

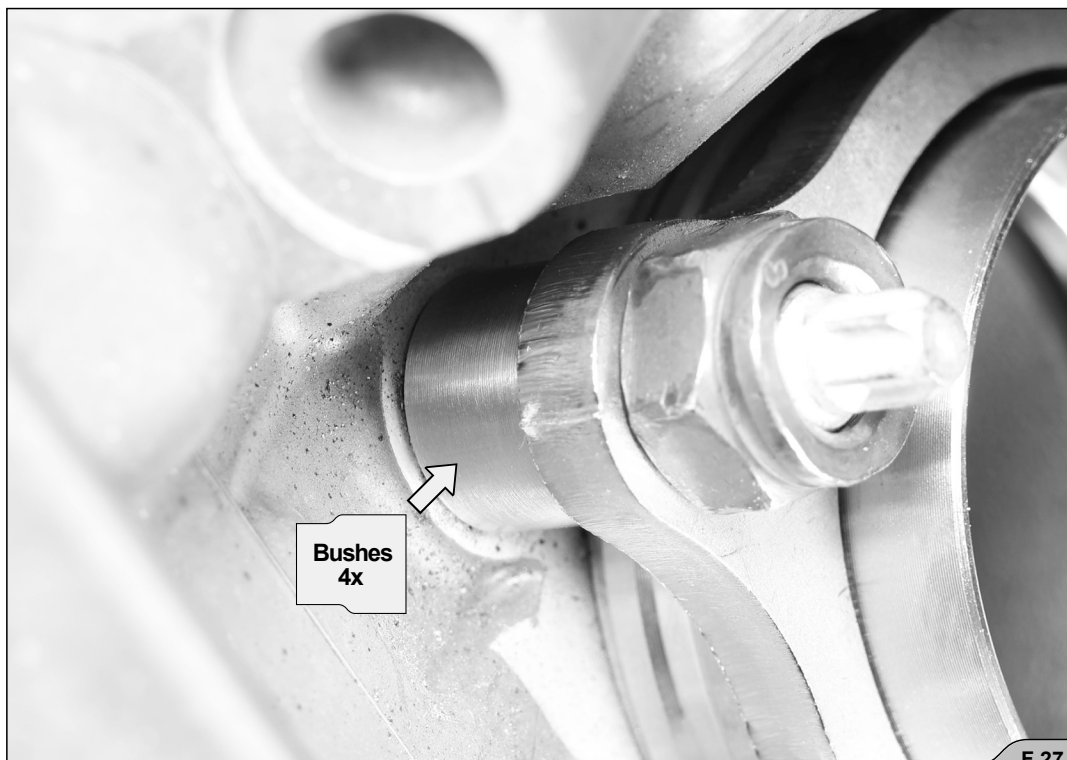

F 27

2. Set up the springs, as shown (F 28).

! **CAUTION:** be careful not to injure yourself or damage any part of the motorcycle during this procedure!



F 28

3. Insert the header tubes into the sleeves and attach the springs (F 29, 30).

! IMPORTANT: make sure, that springs pull the header tubes all the way into the sleeves – use rubber mallet if necessary to tap the connection into place!

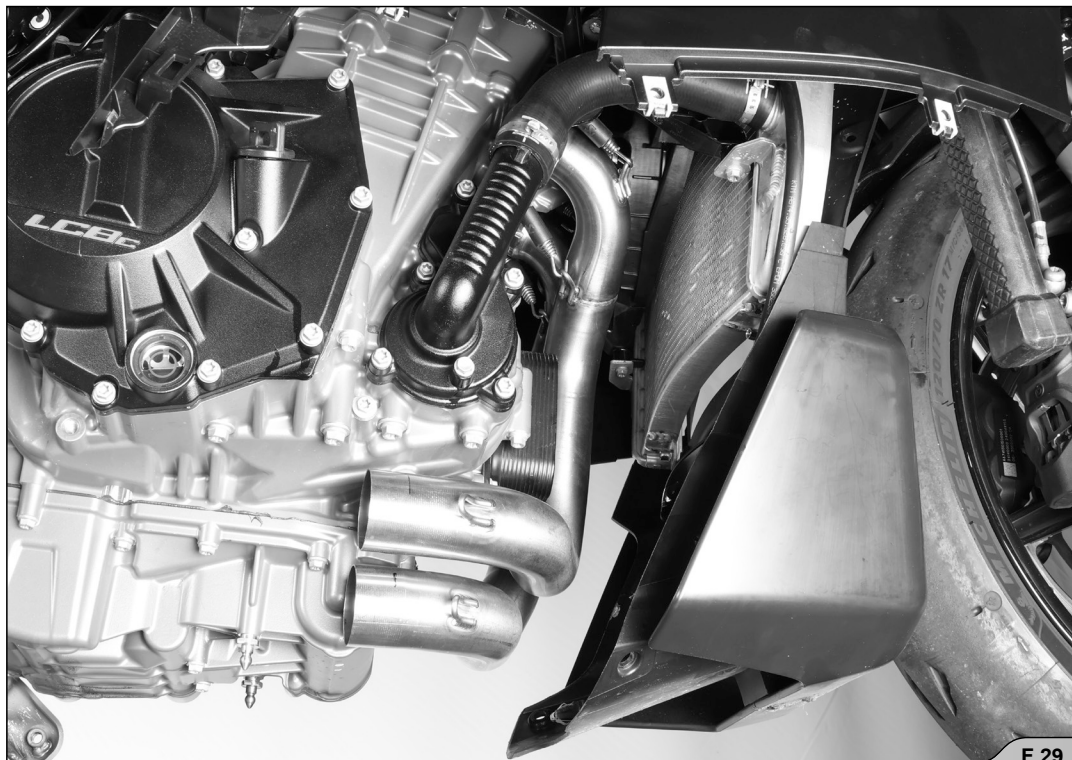

4. Install the lambda sensors into the headers, and tighten them to the specified torque (F 31).
! **IMPORTANT:** make sure not to damage the lambda sensor's electrical leads during this procedure!

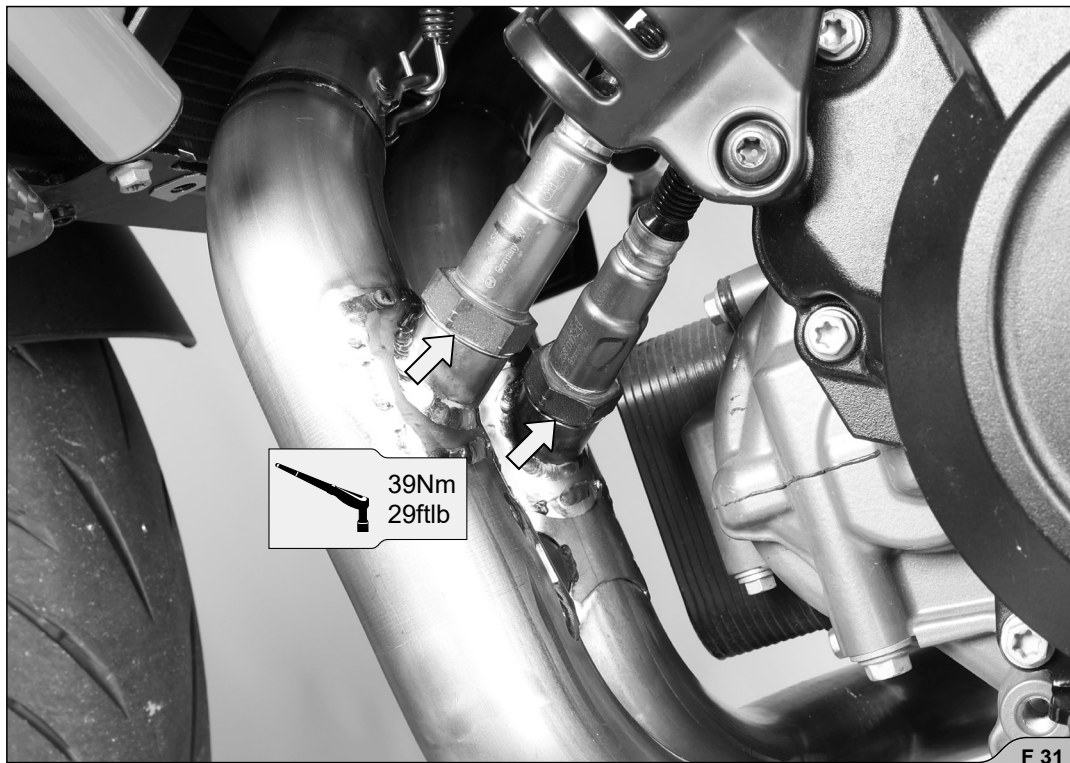

5. Slide the collector onto the headers and attach the springs (F 32).
! **IMPORTANT:** make sure, that springs pull the collector all the way onto the header tubes – use rubber mallet if necessary to tap the connection into place!
✂ **INSTALLATION TIP** (for Evolution exhaust system only): coat the interior side of the inlet bushes of the titanium collector with Akrapovič ceramic anti-seizing grease (white tube).

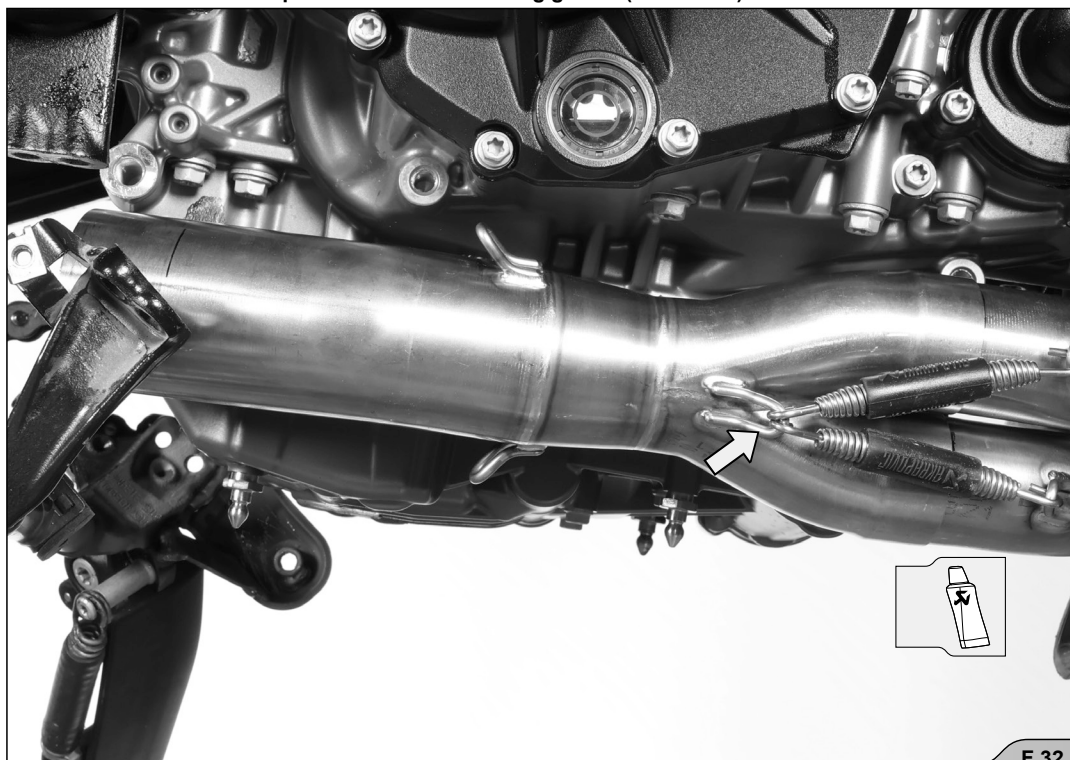

- Slide the pre muffler onto the collector, attach the springs and hand tighten the bracket using bolt and washer from Akrapovič installation kit (F 33, 34).

! **IMPORTANT:** make sure, that springs pull the pre muffler all the way onto the collector tube – use rubber mallet if necessary to tap the connection into place!

W **INSTALLATION TIP** (for Evolution exhaust system only): coat the interior side of the inlet bush of the titanium pre muffler with Akrapovič ceramic anti-seizing grease (white tube).

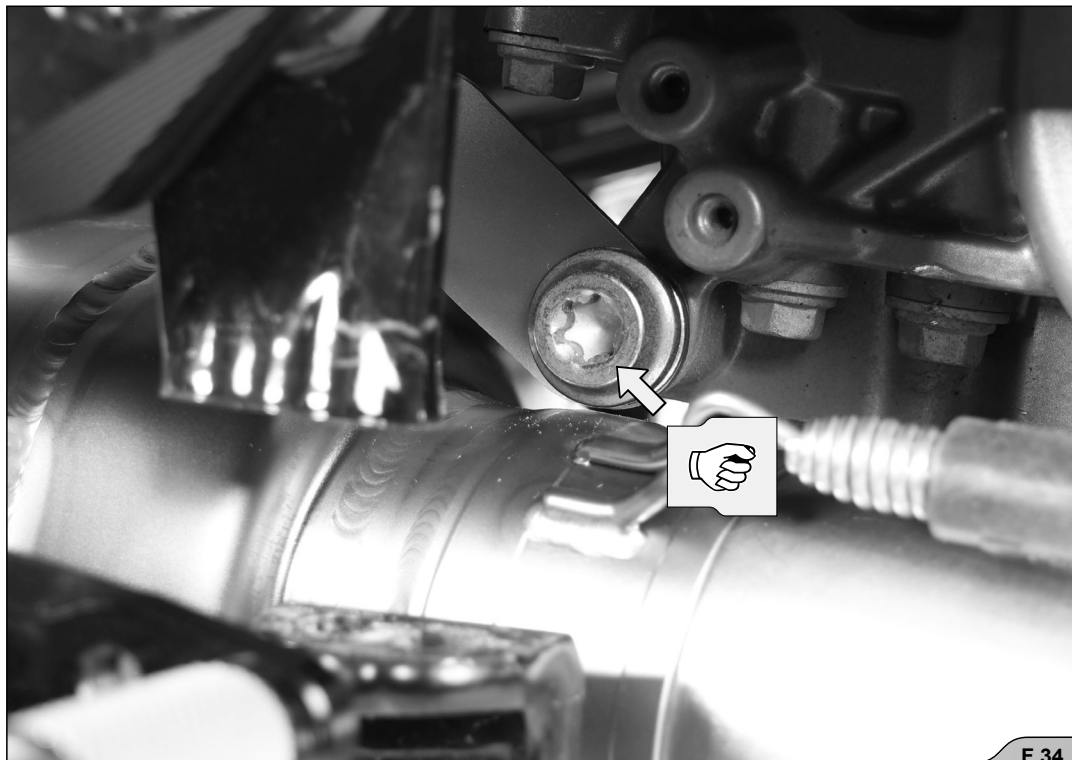
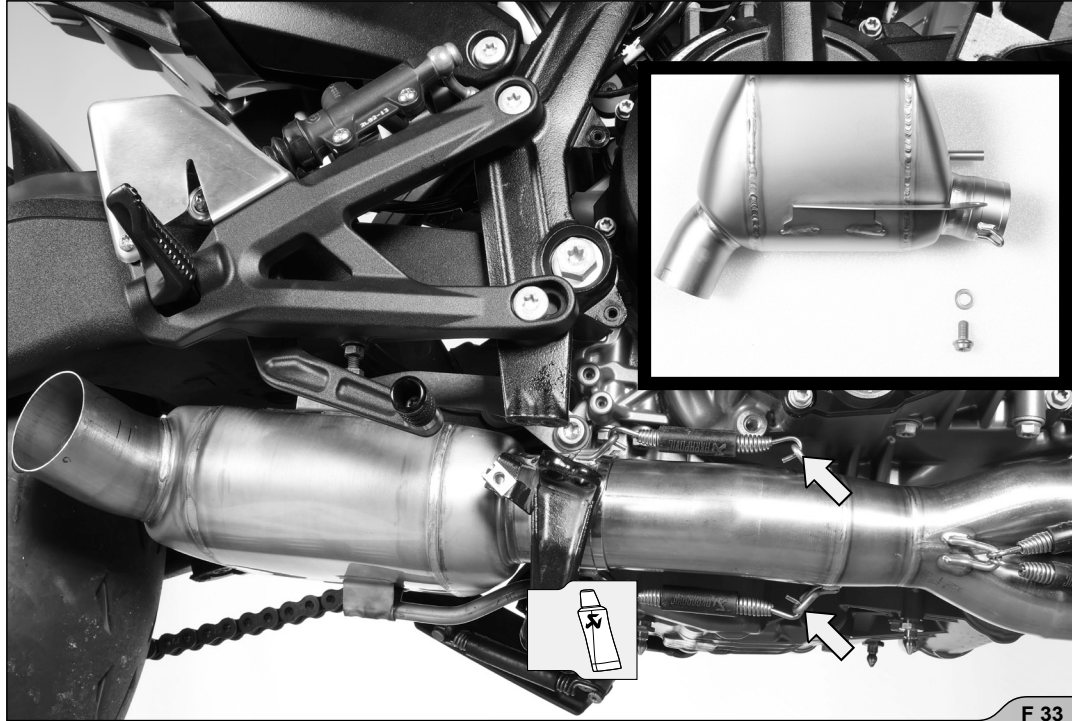

7. Make sure that the pre muffler's bracket is positioned all the way into the bottom of the rubber bracket, as shown (F 35).
✘ INSTALLATION TIP: for easier installation, lubricate the stock rubber damper (WD-40®)*.

*WD-40® is a trademark of the WD-40 Company.

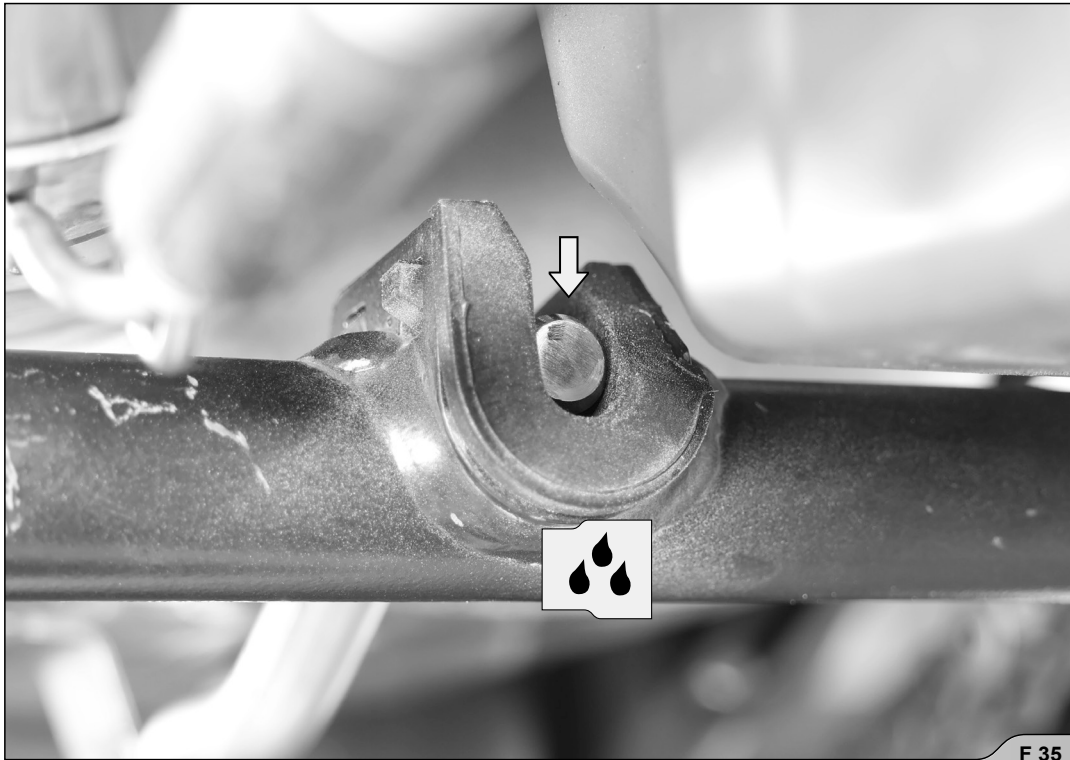

8. Reinstall the bracket onto the motorcycle and tighten the bolts to the specified torque (F 36, 37).
! IMPORTANT: use bolt sealant on marked bolt threads!

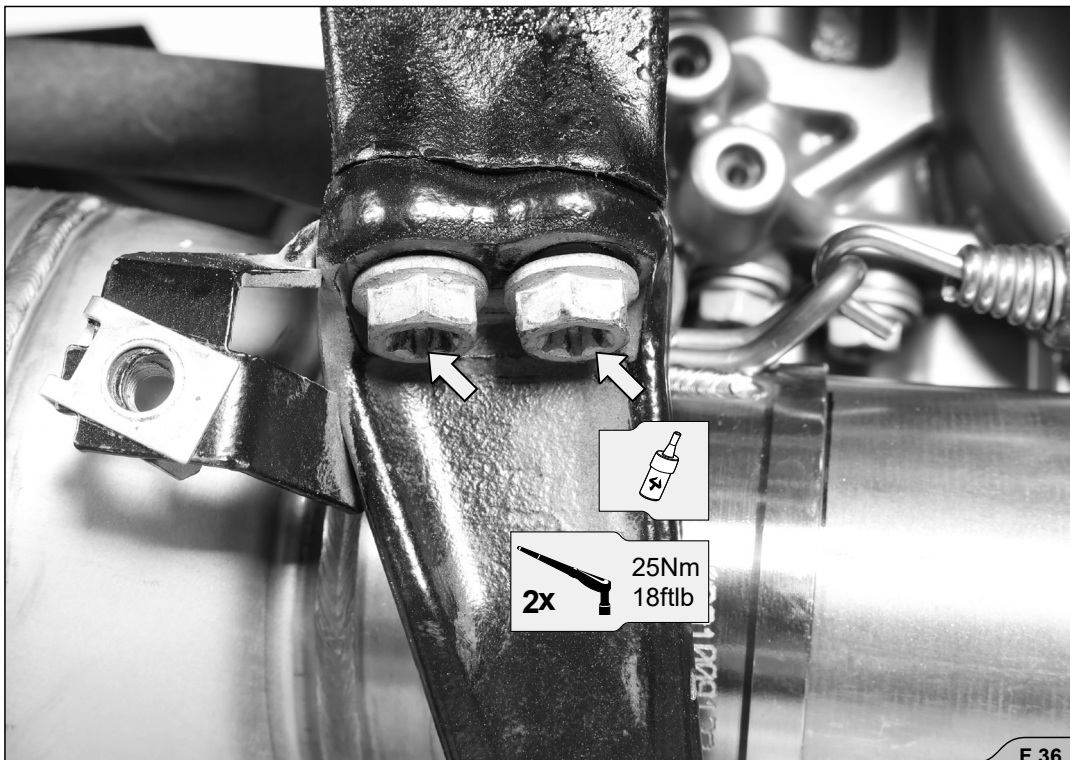

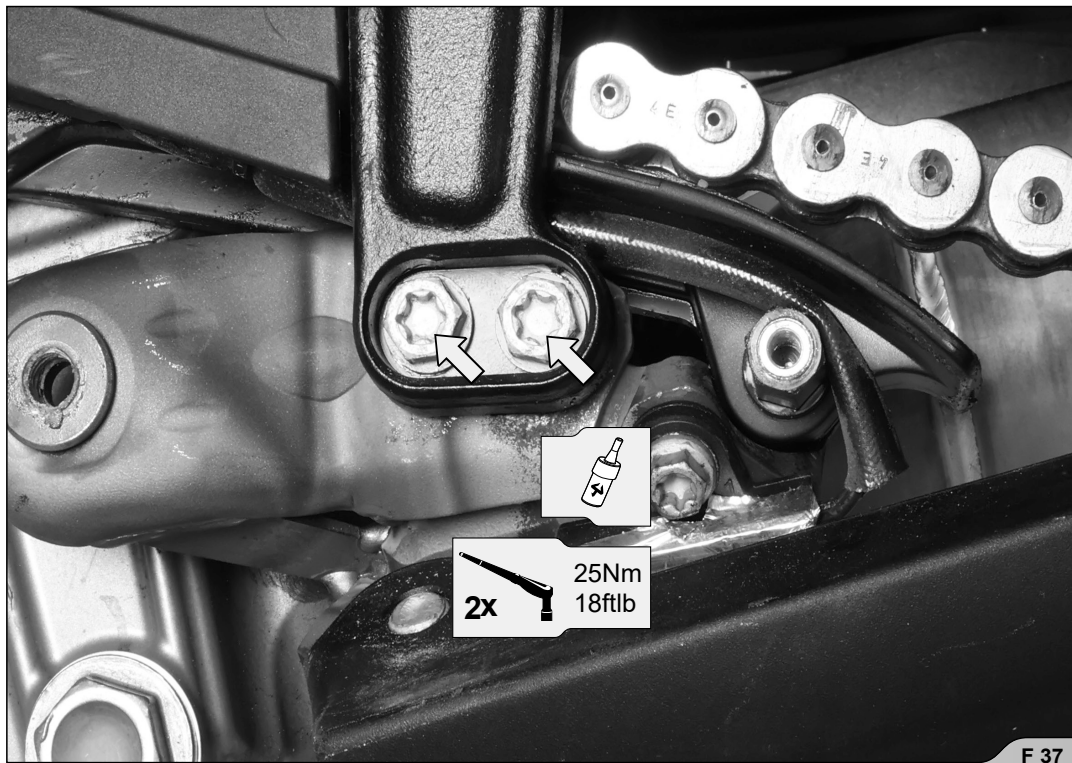

9. Reinstall the shift lever and tighten the bolts to the specified torque (F 38).

! **IMPORTANT:** use bolt sealant on marked bolt threads!

! **CAUTION:** be careful not to injure yourself or damage any part of the motorcycle during this procedure!



10. Install the clamp from Akrapovič installation kit onto the muffler's inlet bush, as shown (F 39).



11. Position the muffler correctly, slide it onto the outlet side of the pre muffler, tighten it to the specified torque onto the bracket using bolt, washers and nut from Akrapovič installation kit (F 40).

✘ INSTALLATION TIP: coat the interior side of the inlet bush of the muffler with Akrapovič ceramic anti-seizing grease (white tube).

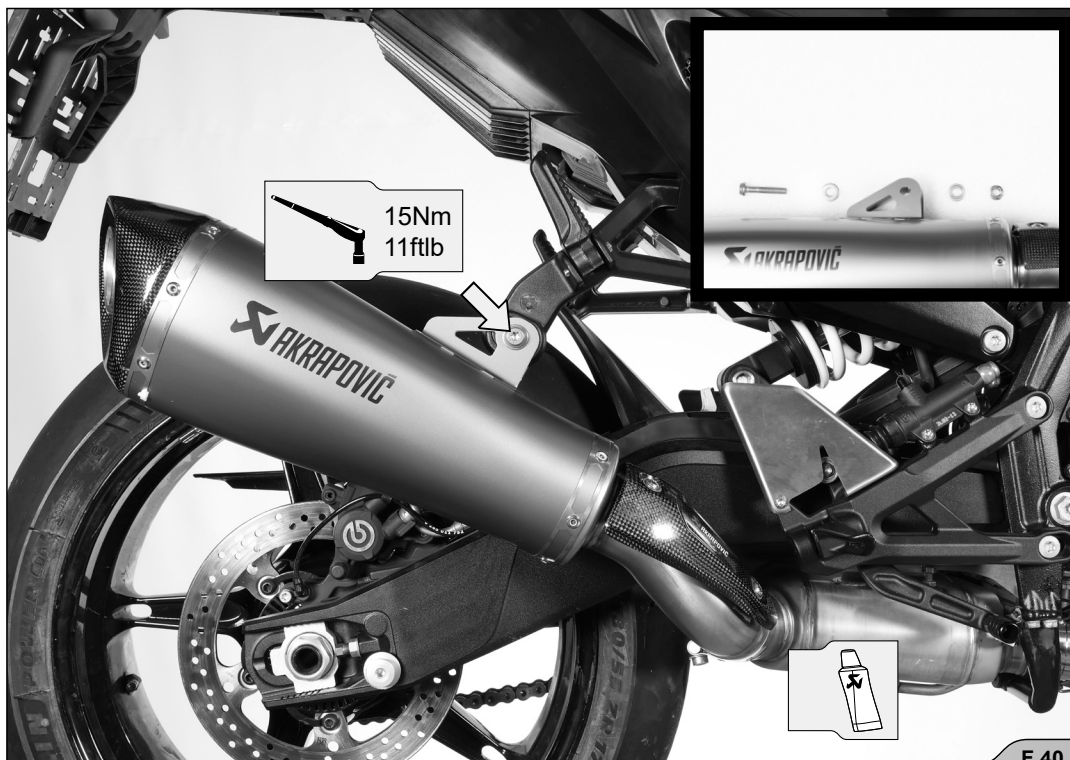

12. Tighten the clamp to the specified torque (F 41).

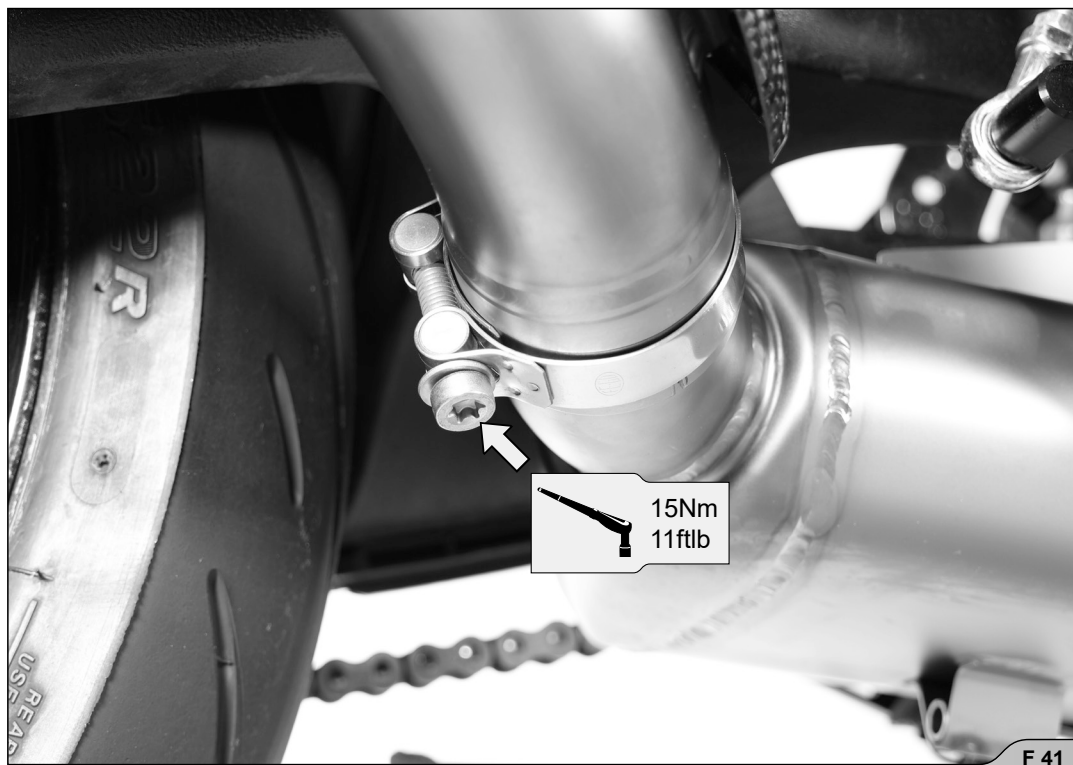

13. Tighten the bracket bolt to the specified torque (F 42).

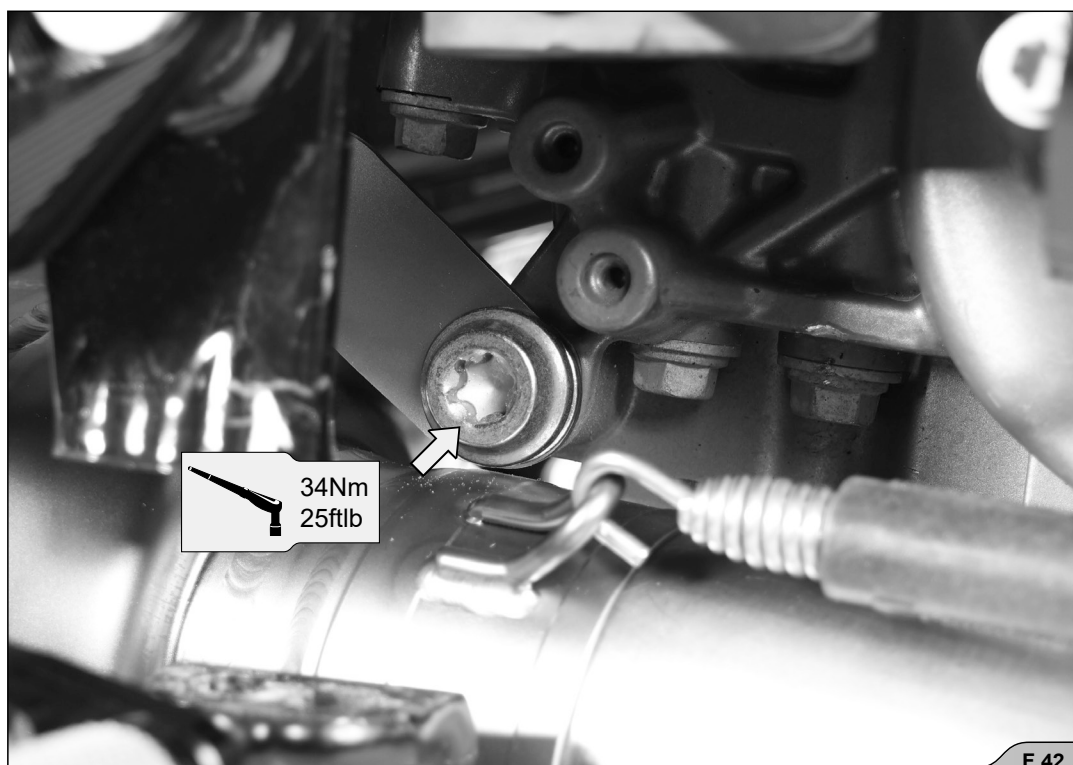

14. Tighten the flange nuts to the specified torque (F 43).

! **CAUTION:** be careful not to injure yourself or damage any part of the motorcycle during this procedure!

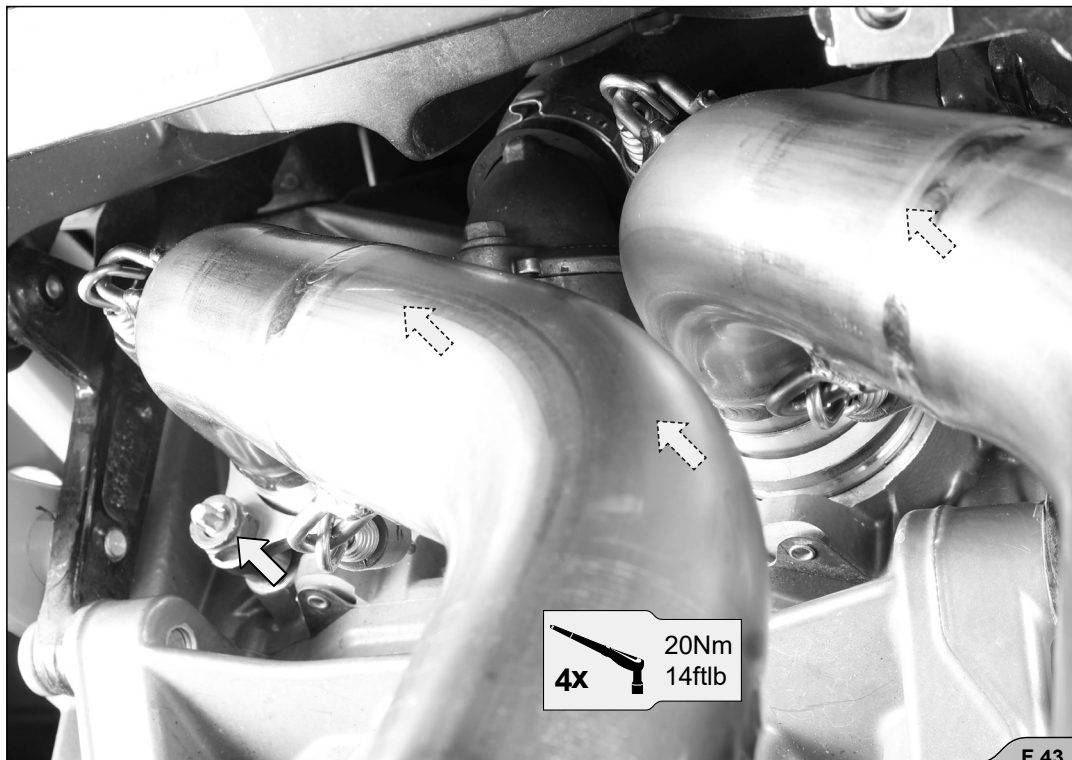

15. For KTM RC 990R model only; reinstall all plastic panels, tighten the bolts and reinstall the plastic fasteners (F 44, 45, 46, 47, 48, 49).

! **IMPORTANT:** make sure not to damage any part of the motorcycle during this procedure!

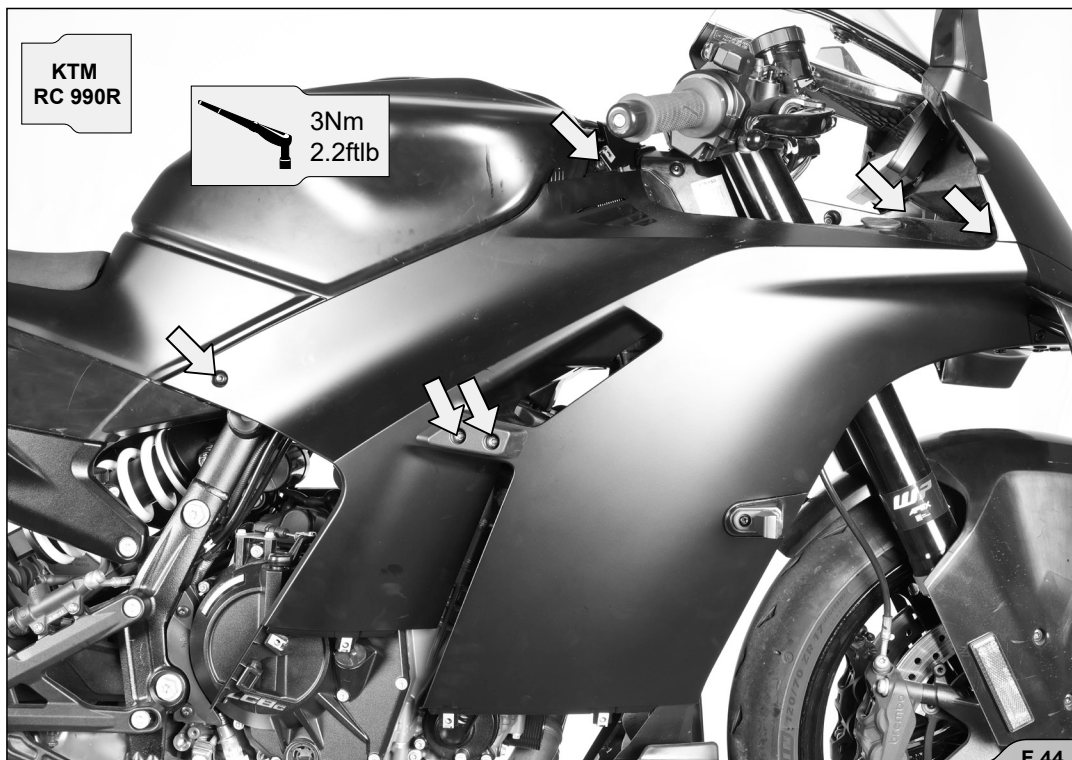

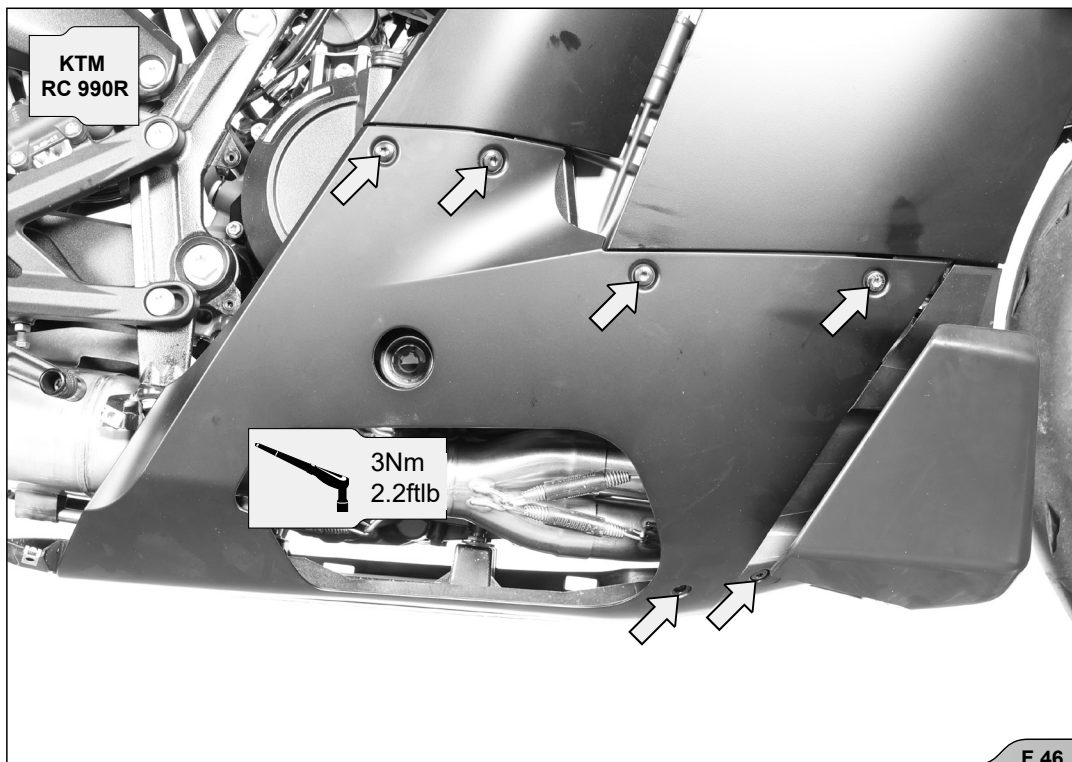
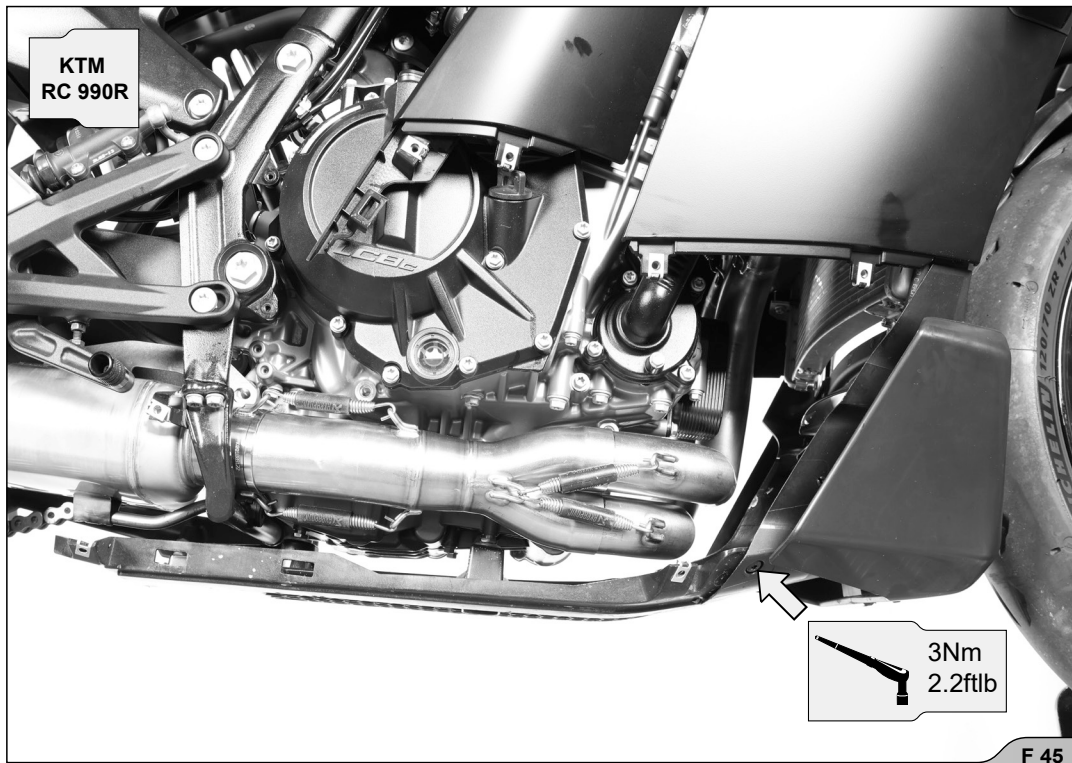

KTM
RC 990R



F 47

KTM
RC 990R



F 48

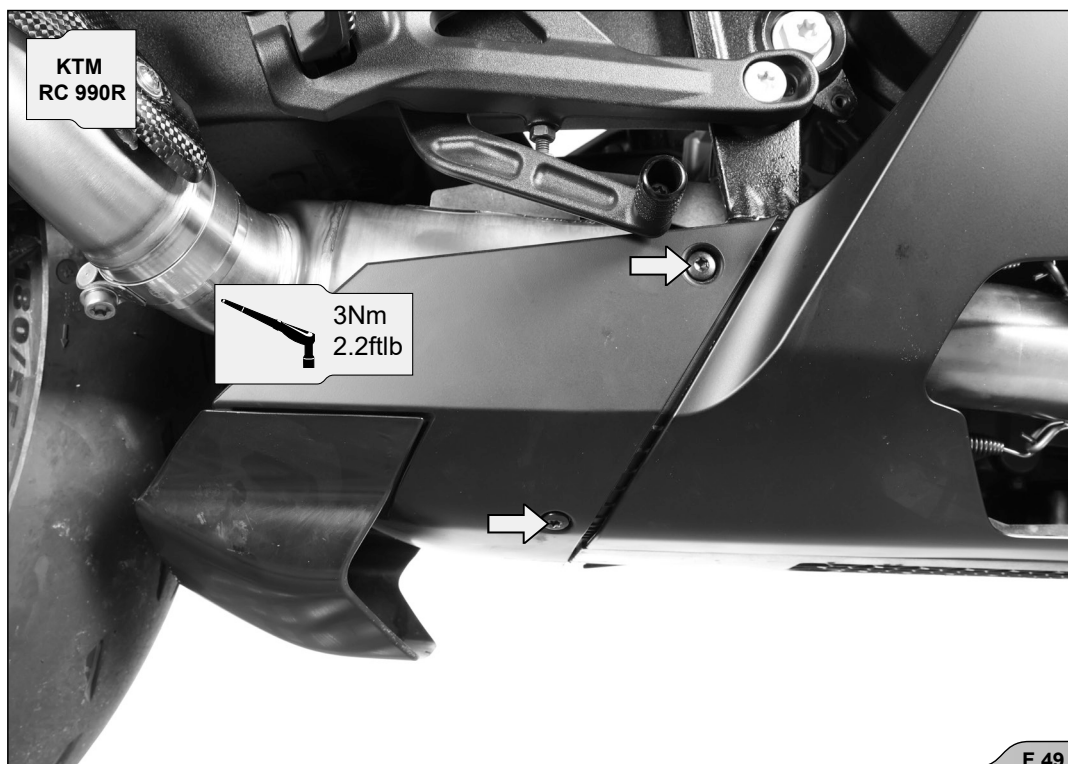

16. Reinstall the plastic cover onto the motorcycle and tighten the bolts to the specified torque (F 50).

! CAUTION: be careful not to injure yourself or damage any part of the motorcycle during this procedure!

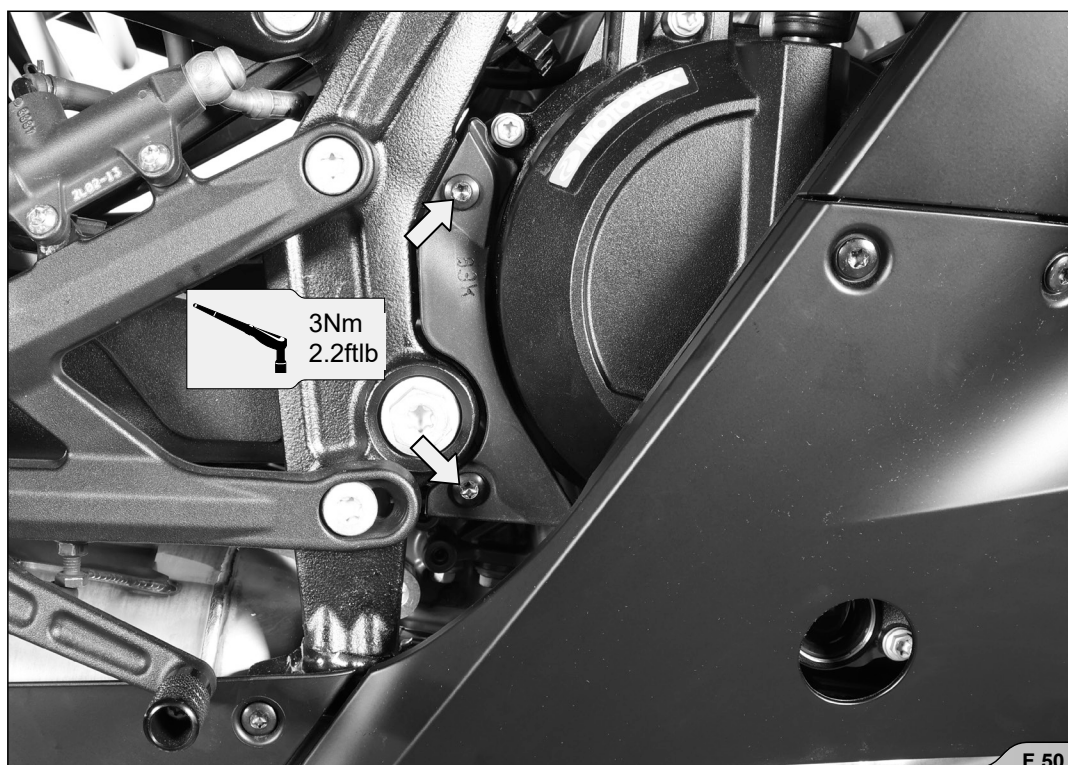

[EMPTY PAGE]

FINAL INSTALLATION AND MAINTENANCE:

Clean grease spots off all exhaust system surfaces, when installation is finished. Cleaning will prevent spots from burning onto the surface. Do not use aggressive chemical cleaners, because they can damage the surface or sticker.

1. Muffler – titanium outer sleeve: use a soft cloth sprayed with a multi-purpose spray lubricant (WD-40® or equivalent)*.
2. Muffler – carbon-fiber outer sleeve: use a soft dry cloth sprayed with all purpose foam cleaner, then wipe with a soft dry cloth.
3. Muffler – carbon-fiber outlet cap: use a soft dry cloth sprayed with all purpose foam cleaner, then wipe with a soft dry cloth.
4. Painted mufflers and parts – use a soft cloth sprayed with all purpose foam cleaner, then wipe with a soft dry cloth.
5. Chrome plated mufflers and parts: use a soft cloth sprayed with all purpose foam cleaner, then wipe with a soft dry cloth.
6. Stainless steel pipes: use a soft cloth sprayed with a contact cleaner, then wipe with a soft dry cloth.
7. Titanium pipes: use a soft cloth sprayed with a multi-purpose spray lubricant (WD-40® or equivalent)*.

*WD-40® is a trademark of the WD-40 Company.

Periodically make sure all the bolts and springs are sufficiently tight.



IMPORTANT: make sure all the bolts are sufficiently tightened. In case the exhaust system touches the cowling or other parts repeat the adjustment of the exhaust system or contact your authorized dealer!



CAUTION: after running engine for 30 minutes, retighten the bolts of the Akrapovič carbon-fiber heat shield!



INSTALLATION TIP: IT IS NORMAL IF WHITE SMOKE COMES OUT OF THE MUFFLER DURING THE FIRST 100 KM AFTER REPLACEMENT.



INSTALLATION TIP: A CHANGE IN THE COLOR OF THE EXHAUST SYSTEM IS NORMAL DUE TO THE HIGH TEMPERATURES.



CAUTION: DO NOT STAND BEHIND THE MUFFLER AT ANY TIME.



IMPORTANT: DO NOT USE AUTOMOTIVE WHEEL CLEANERS OR ANY CLEANING PRODUCTS WHICH CONTAIN ACIDIC ADDITIVES TO CLEAN AKRAPOVIČ EXHAUST SYSTEMS.

TROUBLESHOOTING:

Problem	Possible cause	Solution
Exhaust gas leaks out of the muffler/pipe clamp connections	loosened clamp	tighten the clamp to specified torque
	connection is not completely joined	tap the connection into place and tighten the clamp to specified torque

