

50 SX
50 SX FACTORY EDITION

ART. NO. 3240036EN



Congratulations on your decision to purchase a KTM motorcycle. You are now the owner of a state-of-the-art sports vehicle that will continue to give you and your child pleasure for a long time if you maintain it properly.

We hope your child has many safe and enjoyable rides!

Enter the serial numbers of your vehicle below.

Vehicle identification number (📖 p. 12)	Dealer's stamp
Engine number (📖 p. 12)	

The Owner's Manual contained the latest information for this model series at the time of publication. However, minor differences due to further developments in design cannot be ruled out completely.

All specifications contained herein are non-binding. KTM Sportmotorcycle GmbH specifically reserves the right to modify or delete technical specifications, prices, colors, forms, materials, services, designs, equipment, etc., without prior notice and without specifying reasons, to adapt these to local conditions, as well as to stop production of a particular model without prior notice. KTM accepts no liability for delivery options, deviations from figures and descriptions, misprints, and other errors. The models portrayed partly contain special equipment that does not belong to the regular scope of supply.

© 2024 KTM Sportmotorcycle GmbH, Mattighofen Austria

All rights reserved

Reproduction, even in part, as well as copying of all kinds, is permitted only with the express written permission of the copyright owner.



ISO 9001(12 100 6061)

KTM applies quality assurance processes that lead to the highest possible product quality as defined in the ISO 9001 international quality management standard.

Issued by: TÜV SÜD Management Service GmbH

REG.NO. 12 100 6061

KTM Sportmotorcycle GmbH
Stallhofnerstraße 3
5230 Mattighofen, Austria

This document is valid for the following models:

50 SX (F6001Y4)







50 SX FACTORY EDITION (F6001Y5)



3240036en

24.09.2024

TABLE OF CONTENTS

1	MEANS OF REPRESENTATION	5	8	RIDING INSTRUCTIONS	21
1.1	Symbols used	5	8.1	Checks and maintenance measures when preparing for use	21
1.2	Formats used	5	8.2	Starting the vehicle	21
2	SAFETY ADVICE	6	8.3	Starting off	22
2.1	Use definition – intended use	6	8.4	Riding	22
2.2	Misuse	6	8.5	Braking	23
2.3	Safety advice	6	8.6	Stopping, parking	23
2.4	Degrees of risk and symbols	6	8.7	Transporting	24
2.5	Tampering warning	7	8.8	Refueling	24
2.6	Safe operation	7	9	SERVICE SCHEDULE	26
2.7	Protective clothing	7	9.1	Additional information	26
2.8	Work rules	8	9.2	Service schedule	26
2.9	Environment	8	10	TUNING THE CHASSIS	28
2.10	Owner's Manual	8	10.1	Checking the basic chassis setting with rider's weight	28
3	IMPORTANT NOTES	9	10.2	Air suspension XACT 5235	28
3.1	Manufacturer warranty, implied warranty	9	10.3	Compression damping of the shock absorber	29
3.2	Fuel, auxiliary substances	9	10.4	Adjusting the low-speed compression damping of the shock absorber	29
3.3	Spare parts, accessories	9	10.5	Adjusting the high-speed compression damping of the shock absorber	30
3.4	Service	9	10.6	Adjusting the rebound damping of the shock absorber	30
3.5	Figures	9	10.7	Measuring the dimension of the rear wheel unloaded	31
3.6	Customer service	9	10.8	Checking the static sag of the shock absorber	31
4	VIEW OF VEHICLE	10	10.9	Checking the rider sag of the shock absorber	32
4.1	View of vehicle, left side (example)	10	10.10	Adjusting the spring preload of the shock absorber 	32
4.2	View of vehicle, right side (example)	11	10.11	Adjusting the riding sag 	33
5	SERIAL NUMBERS	12	10.12	Checking the basic setting of the fork	34
5.1	Vehicle identification number	12	10.13	Adjusting the fork air pressure	34
5.2	Frame label	12	10.14	Adjusting the rebound damping of the fork	35
5.3	Engine number	12	10.15	Handlebar position	36
5.4	Fork article number	12	10.16	Adjusting the handlebar position 	36
5.5	Shock absorber article number	13	11	SEAT HEIGHT	38
6	CONTROLS	14	11.1	Seat height adjustment options	38
6.1	Hand brake lever	14	11.2	Adjusting the seat height on the shock absorber 	38
6.2	Throttle grip	14	11.3	Adjusting the seat height on the fork 	39
6.3	Stop button	14	11.4	Adjusting the seat height on the frame 	40
6.4	Opening the fuel tank filler cap	14			
6.5	Closing the fuel tank filler cap	15			
6.6	Fuel tap	15			
6.7	Choke	16			
6.8	Kick starter lever	16			
6.9	Foot brake lever	16			
6.10	Plug-in stand	16			
6.11	Service hour counter	17			
7	PREPARING FOR USE	18			
7.1	Advice on preparing for first use	18			
7.2	Running in the engine	20			

12	SERVICE WORK ON THE CHASSIS.....	43	12.44	Adjusting the chain guide 🛠.....	68
12.1	Raising the motorcycle with a lift stand.....	43	12.45	Checking the frame 🛠.....	69
12.2	Removing the motorcycle from the lift stand.....	43	12.46	Checking the link fork 🛠.....	69
12.3	Bleeding the fork legs.....	43	12.47	Checking the throttle cable routing	69
12.4	Cleaning the dust boots of the fork legs.....	44	12.48	Checking the rubber grip	70
12.5	Removing the fork protector	44	13	BRAKE SYSTEM	71
12.6	Installing the fork protector.....	45	13.1	Checking play of handbrake lever	71
12.7	Removing the fork legs 🛠.....	45	13.2	Adjusting the basic position of the hand brake lever	71
12.8	Installing the fork legs 🛠.....	46	13.3	Checking the brake discs	71
12.9	Removing the lower triple clamp 🛠.....	47	13.4	Checking the front brake fluid level ...	72
12.10	Installing the lower triple clamp 🛠.....	48	13.5	Adding front brake fluid 🛠.....	73
12.11	Checking the steering head bearing play	50	13.6	Checking that the brake linings of the front brake are secured	74
12.12	Adjusting the steering head bearing play 🛠.....	50	13.7	Changing the front brake linings 🛠.....	75
12.13	Lubricating the steering head bearing 🛠.....	51	13.8	Checking the free travel of the foot brake lever	78
12.14	Removing the fuel tank 🛠.....	51	13.9	Adjusting the free travel of the foot brake lever 🛠.....	78
12.15	Installing the fuel tank 🛠.....	52	13.10	Adjusting the basic position of the foot brake lever 🛠.....	79
12.16	Removing the start number plate.....	54	13.11	Checking the rear brake fluid level.....	79
12.17	Installing the start number plate.....	54	13.12	Adding rear brake fluid 🛠.....	80
12.18	Removing front fender.....	55	13.13	Checking that the brake linings of the rear brake are secured.....	81
12.19	Installing front fender.....	55	13.14	Changing the rear brake linings 🛠.....	82
12.20	Removing the left side cover	55	14	WHEELS, TIRES	85
12.21	Installing the left side cover	56	14.1	Removing the front wheel 🛠.....	85
12.22	Removing the right side cover	56	14.2	Installing the front wheel 🛠.....	85
12.23	Installing the right side cover	57	14.3	Removing the rear wheel 🛠.....	86
12.24	Preparing the side cover for securing 🛠.....	57	14.4	Installing the rear wheel 🛠.....	87
12.25	Removing the shock absorber 🛠.....	58	14.5	Checking the tire condition	88
12.26	Installing the shock absorber 🛠.....	58	14.6	Checking tire pressure	89
12.27	Removing the seat	59	14.7	Checking the spoke tension.....	89
12.28	Mounting the seat	59	15	COOLING SYSTEM	91
12.29	Removing the frame protector	59	15.1	Cooling system	91
12.30	Installing the frame protector	60	15.2	Checking the antifreeze and coolant level	91
12.31	Removing the air filter 🛠.....	60	15.3	Checking the coolant level	92
12.32	Installing the air filter 🛠.....	60	15.4	Draining the coolant 🛠.....	92
12.33	Cleaning the air filter and air filter box 🛠.....	61	15.5	Refilling with coolant 🛠.....	93
12.34	Removing the main silencer	61	15.6	Changing the coolant 🛠.....	94
12.35	Installing the main silencer.....	62	16	TUNING THE ENGINE.....	96
12.36	Changing the rock wool on the main silencer 🛠.....	62	16.1	Checking the play in the throttle cable	96
12.37	Removing the engine sprocket cover	63	16.2	Adjusting the play in the throttle cable 🛠.....	96
12.38	Installing the engine sprocket cover ...	63	16.3	Carburetor – idle setting	97
12.39	Checking the chain for dirt.....	64	16.4	Carburetor – adjusting the idle speed 🛠.....	97
12.40	Cleaning the chain	64	16.5	Checking the clutch setting 🛠.....	98
12.41	Checking the chain tension	65			
12.42	Adjusting the chain tension.....	65			
12.43	Checking the chain, rear sprocket, engine sprocket, and chain guide	66			

TABLE OF CONTENTS

16.6	Removing the clutch cover	99
16.7	Adjusting the clutch	99
16.8	Installing the clutch cover	102
17	SERVICE WORK ON THE ENGINE	103
17.1	Checking the gear oil level	103
17.2	Changing the gear oil	103
17.3	Adding the gear oil	104
18	CARBURETOR	106
18.1	Removing the carburetor	106
18.2	Installing the carburetor	108
19	CLEANING, CARE	111
19.1	Cleaning the motorcycle	111
20	STORAGE	113
20.1	Storage	113
20.2	Preparing for use after storage	114
21	TROUBLESHOOTING	115
22	TECHNICAL SPECIFICATIONS	117
22.1	Engine	117
22.2	Engine tightening torques	117
22.3	Carburetor with carburetor tuning	118
22.3.1	Carburetor tuning (Option: Low seat position)	118
22.3.2	Carburetor tuning (Option: High seat position)	119
22.4	Capacities	120
22.4.1	Gear oil	120
22.4.2	Coolant	120
22.4.3	Fuel	120
22.5	Chassis	120
22.6	Tires	121
22.7	Fork	121
22.8	Shock absorber	122
22.9	Chassis tightening torques	122
23	SUBSTANCES	125
24	AUXILIARY SUBSTANCES	127
25	STANDARDS	129
26	LIST OF ABBREVIATIONS	130
	INDEX	132

1.1 Symbols used

The meaning of specific symbols is described below.



Indicates an expected reaction (e.g., of a work step or a function).



Indicates an unexpected reaction (e.g., of a work step or a function).



Indicates work that requires expert knowledge and technical understanding. In the interest of the safety of your child, have these jobs performed in an authorized KTM workshop. Your motorcycle will be cared for there to the highest degree by specially trained experts using the special tools required.



Indicates a page reference (more information is provided on the specified page).



Indicates information with more details or tips.



Indicates the result of a testing step.



Indicates the end of an activity, including potential reworking.

1.2 Formats used

The typographical formats used in this document are explained below.

Proprietary name	Indicates a proprietary name.
Name®	Indicates a protected name.
Brand™	Indicates a brand available on the open market.
<u>Underlined terms</u>	Refer to technical details of the vehicle or indicate technical terms, which are explained in the glossary.

2.1 Use definition – intended use

This vehicle has been designed and built to withstand the normal stresses and strains of racing. This vehicle complies with the currently valid regulations and categories of the top international motorsports organizations.



Info

Only operate this vehicle in closed-off areas remote from public road traffic.

2.2 Misuse

The vehicle must only be used as intended.

Dangers can arise for people, property and the environment through use not as intended.

Any use of the vehicle beyond the intended and defined use constitutes misuse.

Misuse also includes the use of operating and auxiliary fluids which do not meet the required specification for the respective use.

2.3 Safety advice

A number of safety instructions need to be followed to operate the product described safely. Therefore read this instruction and all further instructions included carefully. The safety instructions are highlighted in the text and are referred to at the relevant passages.



Info

Various information and warning labels are attached in prominent locations on the product described. Do not remove any information or warning labels. If they are missing, you or others may not recognize dangers and may therefore be injured.

2.4 Degrees of risk and symbols



Danger

Identifies a danger that will immediately and invariably lead to fatal or serious permanent injury if the appropriate measures are not taken.



Warning

Identifies a danger that is likely to lead to fatal or serious injury if the appropriate measures are not taken.



Caution

Identifies a danger that may lead to minor injuries if the appropriate measures are not taken.

Note

Identifies a danger that will lead to considerable machine and material damage if the appropriate measures are not taken.



Note

Indicates a danger that will lead to environmental damage if the appropriate measures are not taken.

2.5 Tampering warning

Tampering with the noise control system is prohibited. Federal law prohibits the following acts or the causing thereof:

- 1 The removal or rendering inoperative by any person other than for purposes of servicing, repair, or replacement, of any device or element of design incorporated into any new vehicle for the purpose of noise control prior to its sale or delivery to the ultimate purchaser or while it is in use, or
- 2 the use of the vehicle after such device or element of design has been removed or rendered inoperative by any person.

Among those acts presumed to constitute tampering are the acts listed below:

- 1 Removal or puncturing of the main silencers, baffles, header pipes or any other components which conduct exhaust gases.
- 2 Removal or puncturing of parts of the intake system.
- 3 Lack of proper maintenance.
- 4 Replacing moving parts of the vehicle, or parts of the exhaust system or intake system, with parts other than those specified by the manufacturer.

2.6 Safe operation



Danger

Danger of accidents A rider who is not fit to ride poses a danger to him or herself and others.

- Do not operate the vehicle if you are not fit to ride due to alcohol, drugs or medication.
- Do not operate the vehicle if you are physically or mentally impaired.



Danger

Danger of poisoning Exhaust gases are toxic and inhaling them may result in unconsciousness and death.

- Always make sure there is sufficient ventilation when running the engine.
- Use effective exhaust extraction when starting or running the engine in an enclosed space.



Warning

Danger of burns Some vehicle components become hot when the vehicle is operated.

- Do not touch any parts such as the exhaust system, radiator, engine, damper, or brake system before the vehicle parts have cooled down.
- Let the vehicle parts cool down before you perform any work on the vehicle.

Only operate the vehicle when it is in perfect technical condition, in accordance with its intended use, and in a safe and environmentally compatible manner.

The vehicle should only be used by trained persons.

Have malfunctions that impair safety promptly eliminated by an authorized KTM workshop.

Adhere to the information and warning labels on the vehicle.

2.7 Protective clothing



Warning

Risk of injury Missing or poor protective clothing presents an increased safety risk.

- Ensure your child wears appropriate protective clothing such as helmet, boots, gloves as well as trousers and a jacket with protectors on all rides.
- Always use protective clothing for your child that is in good condition and meets the legal requirements.
- When you ride a motorcycle, set an example for your child and wear suitable protective clothing.

2.8 Work rules

Unless specified otherwise, the ignition must be turned off during all work (models with ignition lock, models with transponder key) or the motor must be at a standstill (models without ignition lock or transponder key). Special tools are necessary for certain tasks. If these special tools are not included in the scope of supply of the vehicle, the special tools can be ordered using the specified article number. Example: bearing puller (15112017000)

Unless otherwise noted, normal conditions apply to all tasks and descriptions.

Ambient temperature	20 °C (68 °F)
Ambient air pressure	1,013 mbar (14.69 psi)
Relative air humidity	60 ± 5 %

During assembly, use new parts to replace parts which cannot be reused (e.g. self-locking screws and nuts, expansion screws, seals, sealing rings, O-rings, pins, and lock washers).

In the case of certain screw connections, a thread locker (e.g., **Loctite®**) is required. Observe the manufacturer's instructions.

If a thread locker (e.g. **Precote®**) has already been applied to a new part, do not apply any additional thread locker.

After disassembly, clean the parts that are to be reused and check them for damage and wear. Change damaged or worn parts.

Ensure that the work area is clean and clean components before disassembly if necessary. Penetrating dirt can lead to increased wear and consequential damage.

After completing a repair or service work, check the operating safety of the vehicle.

2.9 Environment

If you use your motorcycle responsibly, you can ensure that problems and conflicts do not occur. To protect the future of the motorcycle sport, make sure that you use your motorcycle legally, display environmental consciousness, and respect the rights of others.

When disposing of used oil, other operating and auxiliary fluids, and used components, comply with the laws and regulations of the respective country.

Because motorcycles are not subject to the EU regulations governing the disposal of used vehicles, there are no legal regulations that pertain to the disposal of an end-of-life motorcycle. Your authorized KTM dealer will be glad to advise you.

2.10 Owner's Manual

It is important that you read this Owner's Manual carefully and completely before your child makes his or her first trip. The Owner's Manual contains useful information and many tips for you and your child on how to operate, handle, and service your motorcycle. This is the only way for you to find out how to ideally tune the vehicle and how to protect your child from injury.

Tip

Store the Owner's Manual on your terminal device, for example, so that you can read it whenever you need to.

If you would like to know more about the vehicle or have questions on the material you read, please contact an authorized KTM dealer.

The Owner's Manual is an important component of the vehicle. If the vehicle is sold, the Owner's Manual must be downloaded again by the new owner.

The Owner's Manual can be downloaded several times using the QR code or the link on the delivery certificate.

The Owner's Manual is also available for download from your authorized KTM dealer and on the KTM website. A printed copy can also be ordered from your authorized KTM dealer.

International KTM Website: KTM.COM

3.1 Manufacturer warranty, implied warranty

The work prescribed in the service schedule must be carried out in an authorized KTM workshop only and confirmed in the electronic proof of service, since otherwise no warranty claims will be recognized. Damage or secondary damage caused by tampering with and/or conversions on the vehicle are not covered by the manufacturer warranty.

3.2 Fuel, auxiliary substances



Note

Environmental hazard Improper handling of fuel is a danger to the environment.

- Do not allow fuel to enter the groundwater, the soil, or the sewage system.

Use fuels and auxiliary substances in accordance with the Owner's Manual and specification.

3.3 Spare parts, accessories

For the safety of your child, only use spare parts and accessory products that are approved and/or recommended by KTM and have them installed by an authorized KTM workshop. KTM accepts no liability for other products and any resulting damage or loss.

Certain spare parts and accessory products are specified in parentheses in the descriptions. Your authorized KTM dealer will be glad to advise you.

The current **KTM PowerParts** for your vehicle can be found on the KTM website.
International KTM Website: KTM.COM

3.4 Service

A prerequisite for perfect operation and prevention of premature wear is that the service, care, and tuning work on the engine and chassis is properly carried out as described in the Owner's Manual. An incorrect suspension setting can lead to damage and breakage of chassis components.

Use of the vehicle under difficult conditions, such as on sand or on wet, dusty and muddy surfaces, can result in significantly increased wear of components, such as the drive train, brake system, air filter or suspension components. For this reason, it may be necessary to inspect or replace parts before the next scheduled service.

It is imperative that you adhere to the stipulated run-in times and service intervals. If you observe these exactly, you will ensure a much longer service life for your motorcycle.

The relevant mileage or time interval is whichever occurs first.

3.5 Figures

The figures contained in the manual may depict special equipment.

In the interest of clarity, some components may be shown disassembled or may not be shown at all. It is not always necessary to disassemble the component to perform the activity in question. Please follow the instructions in the text.

3.6 Customer service

Your authorized KTM dealer will be happy to answer any questions you may have on your vehicle and KTM.

A list of authorized KTM dealers can be found on the KTM website.
International KTM Website: KTM.COM

4 VIEW OF VEHICLE

4.1 View of vehicle, left side (example)

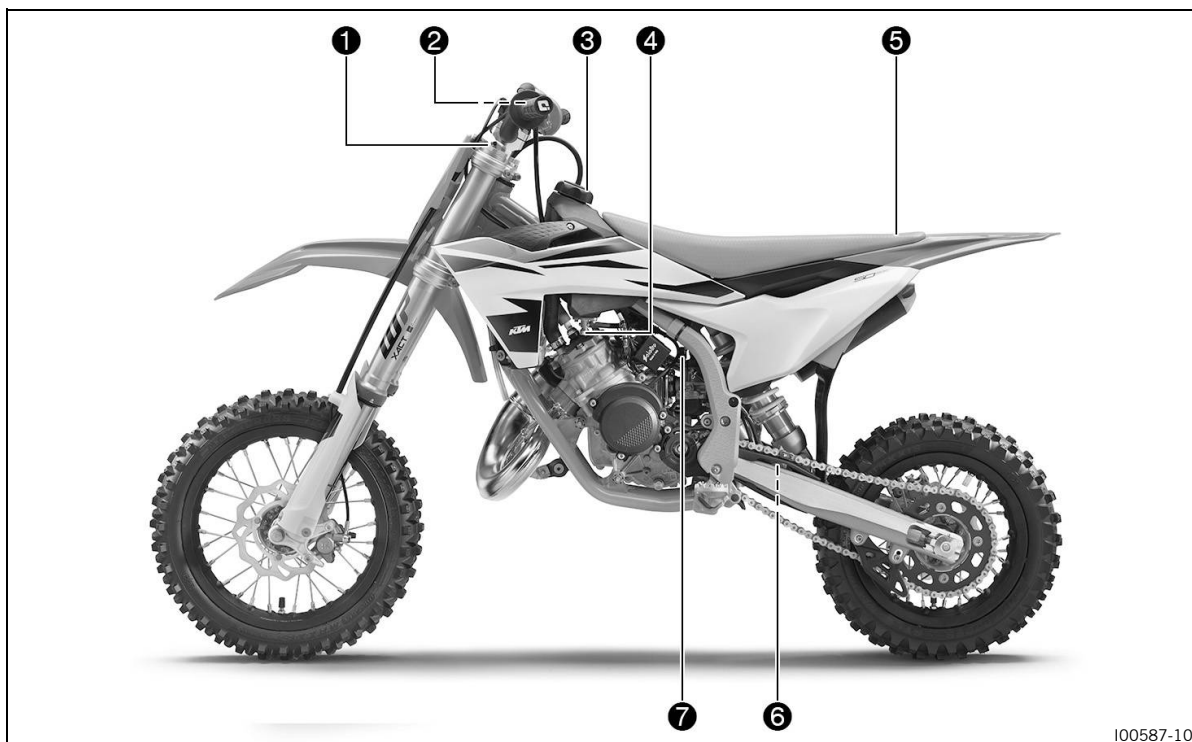

I00587-10

- ❶ Valve for fork airpump
- ❷ Stop button (📖 p. 14)
- ❸ Fuel tank filler cap
- ❹ Fuel tap (📖 p. 15)
- ❺ Quick release of seat
- ❻ Shock absorber compression adjustment
- ❼ Choke

4.2 View of vehicle, right side (example)

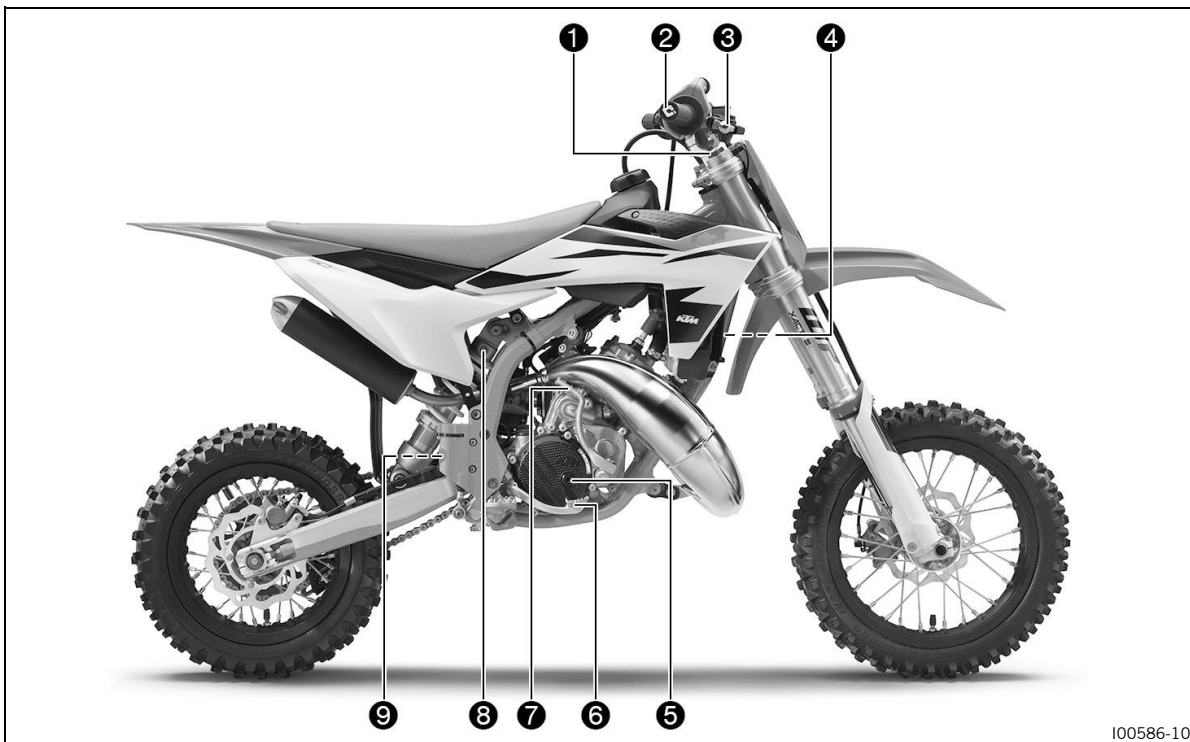

I00586-10

- ❶ Fork rebound adjustment
- ❷ Throttle grip (📖 p. 14)
- ❸ Hand brake lever (📖 p. 14)
- ❹ Vehicle identification number (📖 p. 12)
- ❺ Clutch adjuster
- ❻ Foot brake lever (📖 p. 16)
- ❼ Kick starter lever (📖 p. 16)
- ❽ Shock absorber rebound adjuster
- ❾ Level viewer for brake fluid, rear

5 SERIAL NUMBERS

5.1 Vehicle identification number

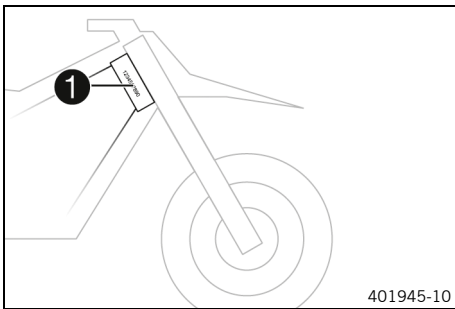

The vehicle identification number **1** is stamped on the right side of the steering head.

5.2 Frame label

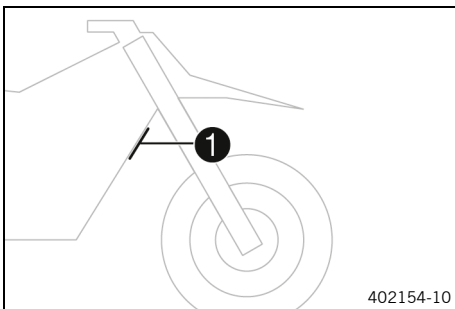

Frame label **1** is located on the front frame tube.

5.3 Engine number

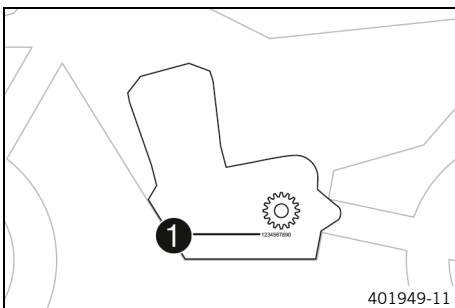

The engine number **1** is located on the left side of the engine under the engine sprocket.

5.4 Fork article number

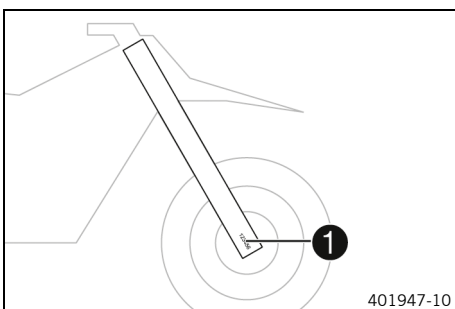

The fork article number **1** is stamped on the outside of the axle clamp.

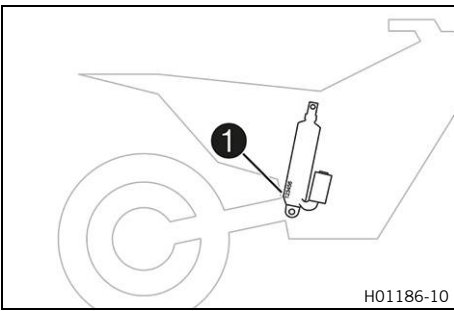
5.5 Shock absorber article number

The shock absorber article number **1** is stamped on the bottom of the shock absorber toward the right-hand side.

6.1 Hand brake lever

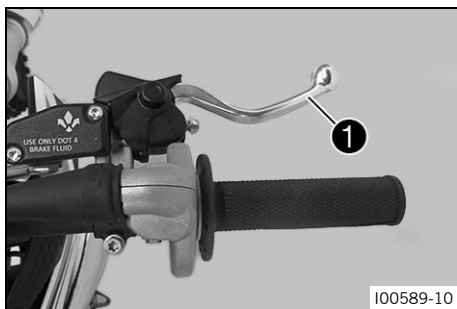

Hand brake lever **1** is fitted on the right side of the handlebar. The hand brake lever is used to activate the front brake.

6.2 Throttle grip

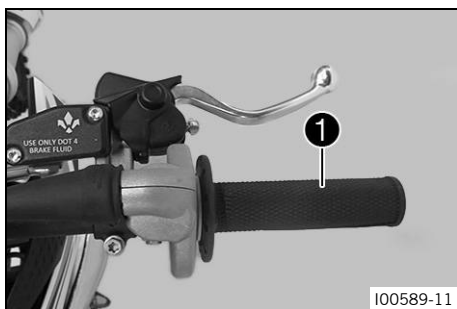

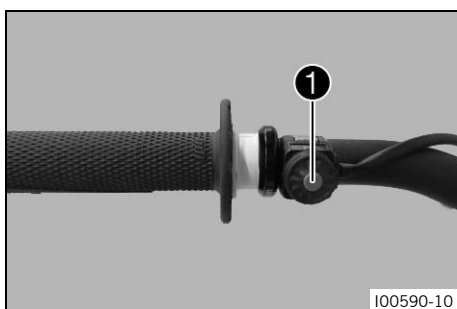

Throttle grip **1** is fitted on the right side of the handlebar.

6.3 Stop button



The stop button **1** is fitted on the left side of the handlebar.

Possible states

- The stop button  is in the basic position – In this position, the ignition circuit is closed and the engine can be started.
- Stop button  pressed – In this position, the ignition circuit is interrupted, a running engine stops, and a non-running engine will not start.

6.4 Opening the fuel tank filler cap



Danger

Fire hazard Fuel is highly flammable.

The fuel in the fuel tank expands when warm and can escape if overfilled.

- Do not fuel the vehicle in the vicinity of open flames or lit cigarettes.
- Switch off the engine for refueling.
- Make sure that no fuel is spilled; particularly not on hot parts of the vehicle.
- If any fuel is spilled, wipe it off immediately.
- Observe the specifications for refueling.



Warning

Danger of poisoning Fuel is harmful to health.

- Avoid skin, eye and clothing contact with fuel.
- Immediately consult a doctor if you swallow fuel.
- Do not inhale fuel vapors.
- Rinse the affected area immediately with plenty of water in the event of contact with the skin.
- Rinse the eyes thoroughly with water, and consult a doctor in case of fuel contact with the eyes.
- Change your clothing if fuel spills on them.
- Keep fuels correctly in a suitable canister, and out of the reach of children.



Note

Environmental hazard Improper handling of fuel is a danger to the environment.

- Do not allow fuel to enter the groundwater, the soil, or the sewage system.

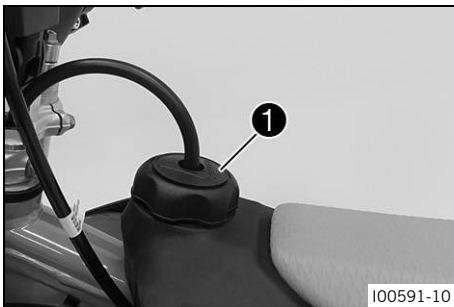

- Turn fuel tank filler cap **1** counterclockwise and lift it off.

6.5 Closing the fuel tank filler cap

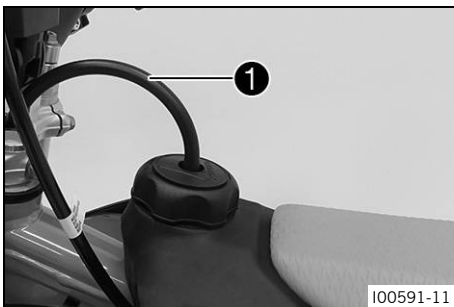

- Mount the fuel tank filler cap and turn it clockwise until the fuel tank is tightly closed.



Info

Route fuel tank breather hose **1** without kinks.

6.6 Fuel tap

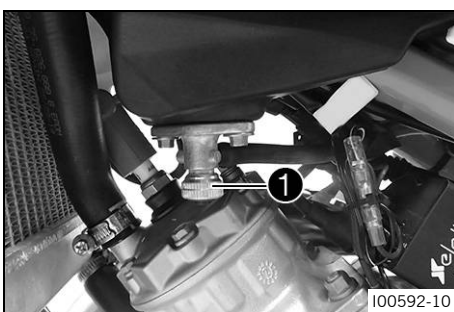

Fuel tap **1** is on the left of the fuel tank.

Possible states

- Fuel tap is closed – The knurled screw is turned all the way clockwise. Fuel cannot flow out of the fuel tank.
- Fuel tap is open – The knurled screw is turned all the way counterclockwise. Fuel can flow out of the fuel tank.

6.7 Choke

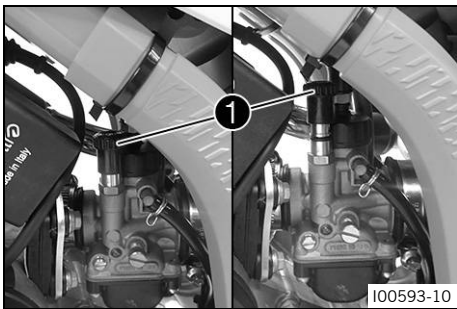

Choke ❶ is fitted on the left side of the carburetor. Activating the choke function frees a drill hole in the carburetor through which the engine can draw extra fuel. This results in a richer fuel-air mixture, which is needed for a cold start.

i Info
If the engine is warm, the choke function must be deactivated.

Possible states

- Choke function activated – The choke lever is pulled out to the stop.
- Choke function deactivated – The choke lever is pushed in to the stop.

6.8 Kick starter lever

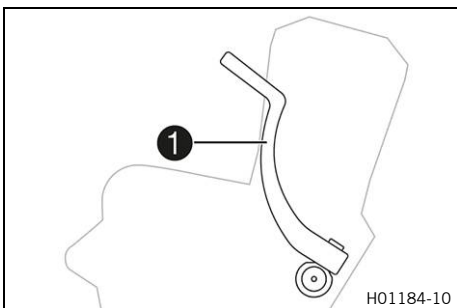

Kick starter lever ❶ is fitted on the right side of the engine. The kick starter lever can be swiveled.

i Info
Before riding, swing the kick starter lever inwards towards the engine.

6.9 Foot brake lever

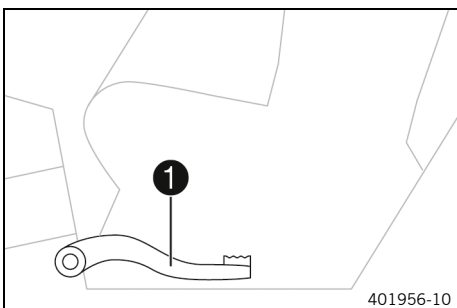

Foot brake lever ❶ is located in front of the right footrest. The rear brake is engaged with the foot brake lever.

6.10 Plug-in stand

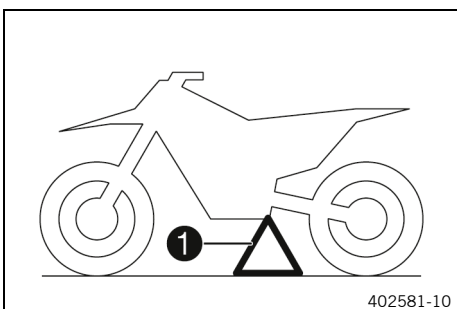

The fixture for plug-in stand ❶ is located on the frame on the left side of the vehicle. The plug-in stand is used to park the motorcycle.

i Info
Remove the plug-in stand before riding.

6.11 Service hour counter

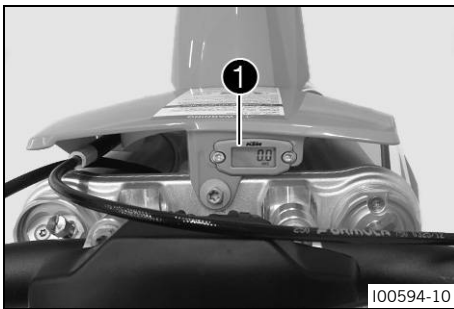

Service hour counter ① is attached to the top of the start number plate.

It shows the total number of service hours of the engine.

The service hour counter begins counting when the engine is started and stops when the engine is switched off.



Info

The value indicated by the service hour counter cannot be cleared or adjusted.

7.1 Advice on preparing for first use



Warning

Danger of accidents A lack of physical and mental readiness on the part of the child poses a major risk.

Children often underestimate or fail to recognize dangerous situations.

- Your child must already be able to ride a bicycle.
- Your child must be able to put the vehicle upright independently after a fall.
- Your child must understand that regulations and instructions from you or from other guardians must be followed.
- Make it clear to your child that they should not, under any circumstances, operate the vehicle without supervision.
- Make it clear to your child that he or she may only drive at speeds corresponding to the child's riding abilities and the road conditions.
- Do not ask too much of your child.
Make sure that their stamina, riding technique and motivation are at the necessary levels.
- Only let your child ride on the vehicle if they are physically and mentally ready.



Warning

Risk of injury Missing or poor protective clothing presents an increased safety risk.

- Ensure your child wears appropriate protective clothing such as helmet, boots, gloves as well as trousers and a jacket with protectors on all rides.
- Always use protective clothing for your child that is in good condition and meets the legal requirements.
- When you ride a motorcycle, set an example for your child and wear suitable protective clothing.



Warning

Danger of crashing Different tire tread patterns on the front and rear wheel impair the handling characteristic.

Different tire tread patterns can make the vehicle significantly more difficult to control.

- Make sure that only tires with a similar tire tread pattern are fitted to the front and rear wheel.



Warning

Danger of accidents An unadapted riding style constitutes a major risk.

- Ensure that your child adapts the riding speed to the road conditions and to his or her riding abilities.



Warning

Danger of accidents The vehicle is not designed to carry passengers.

- Make it clear to your child that he or she must not carry a passenger.



Warning

Danger of accidents The brake system fails in the event of overheating.

If the foot brake lever is not released, the brake linings drag continuously.

- Ensure that your child raises his or her foot from the foot brake lever if he or she does not want to brake.



Warning

Danger of accidents The suspension components will become damaged or destroyed if overloaded.

- Do not exceed the maximum permissible weight of the rider.



Warning

Risk of injury People who act without authorization may not be familiar with the vehicle.

- Do not leave the vehicle unattended if the engine is running.
- Protect the vehicle against access by unauthorized persons.



Info

When using the motorcycle, remember that others may be disturbed by excessive noise.

- Ensure that the pre-sales inspection work has been carried out by an authorized KTM workshop.
- ✓ You will receive a delivery certificate when the vehicle is handed over.
- Read through the entire Owner's Manual together with your child before riding for the first time.



Info

Pay special attention to the safety instructions and to the risk of injury. Explain to your child the techniques of riding and falling, e.g., how shifting weight can influence handling characteristics.

- Familiarize your child with the controls.
- Adjust basic position of the hand brake lever. (📖 p. 71)
- Adjust the basic position of the foot brake lever. 🦶 (📖 p. 79)
- Before using the vehicle for the first time, ensure that the basic settings of the chassis are suitable for the weight of your child.



Info

Contact your authorized KTM workshop for information on different throttle variants.

- Allow your child to become accustomed to the handling of the motorcycle on suitable terrain, preferably on a large, open meadow.



Info

To give your child a feeling for the brake system, you should push your child at first. Do not start the engine until your child is able to apply the necessary front brake pressure. Initially, let your child ride to another person who can help your child stop and turn.

- Erect obstacles for your child to navigate around so that your child becomes accustomed to handling the vehicle.
- Your child should also try to ride as slowly as possible and in a standing position to get a better feeling for the motorcycle.
- Your child should not ride on terrain that exceeds your child's capabilities and experience.
- Your child should hold the handlebar firmly with both hands and keep his or her feet on the footrests when riding.
- Make sure the maximum permissible weight of the rider is not exceeded.

Guideline

Maximum rider weight	45 kg (99 lb.)
Maximum rider size	< 130 cm (< 51.2 in)

- Check the spoke tension. (📖 p. 89)



Info

The spoke tension must be checked after half an hour of operation.

- Run the engine in. (📖 p. 20)



7.2 Running in the engine

- During the running-in time, do not exceed the specified engine load.

Guideline

Maximum engine performance	
During the first 3 operating hours	< 70 %
During the first 5 operating hours	< 100 %

- Avoid fully opening the throttle.



8.1 Checks and maintenance measures when preparing for use

i Info

Before every trip, check the condition of the vehicle and ensure that it is safe to operate. The vehicle must be in perfect technical condition when it is being operated.

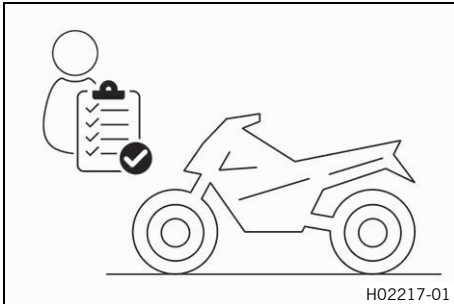

- Check the gear oil level. (📖 p. 103)
- Check the front brake fluid level. (📖 p. 72)
- Check the rear brake fluid level. (📖 p. 79)
- Check that the brake linings of the front brake are secured. (📖 p. 74)
- Check that the brake linings of the rear brake are secured. (📖 p. 81)
- Check that the brake system is functioning properly.
- Check the coolant level. (📖 p. 92)
- Check the chain for dirt. (📖 p. 64)
- Check the chain, rear sprocket, engine sprocket, and chain guide. (📖 p. 66)
- Check the chain tension. (📖 p. 65)
- Check the tire condition. (📖 p. 88)
- Check tire pressure. (📖 p. 89)
- Check the spoke tension. (📖 p. 89)

i Info

The spoke tension must be checked regularly as incorrect spoke tension will strongly impair riding safety.

- Clean the dust boots of the fork legs. (📖 p. 44)
- Bleed the fork legs. (📖 p. 43)
- Check the air filter.
- Check the settings of all controls and ensure that they can be operated smoothly.
- Check all screws, nuts, and hose clamps regularly for tightness.
- Check the fuel level.



8.2 Starting the vehicle



Danger

Danger of poisoning Exhaust gases are toxic and inhaling them may result in unconsciousness and death.

- Always make sure there is sufficient ventilation when running the engine.
- Use effective exhaust extraction when starting or running the engine in an enclosed space.

Note

Engine failure High rpm with a cold engine negatively impacts the lifespan of the engine.

- Ensure that the engine is always warmed up at low engine speeds.

i Info

If the motorcycle is unwilling to start, the cause can be old fuel in the float chamber. The flammable elements of the fuel evaporate after a long time of standing.
If the float chamber is filled with fresh fuel, the engine starts immediately.

Preliminary work

- Raise the motorcycle with a lift stand. (📖 p. 43)

The motorcycle has been out of use for more than 1 week

- Empty the carburetor float chamber. 🛠️
- Turn the knurled screw on the fuel tap all the way counterclockwise.
 - ✓ Fuel can flow from the fuel tank to the carburetor.

The engine is cold

- Pull the choke knob up all the way to the stop and turn it by a max. ¼ turn.
- Forcefully step on the kick starter lever, pushing it all the way forward.

i Info

Do not open the throttle.

i Info

If the motorbike does not start after 5 actuations of the kick-start lever, apply the front brake and lift the motorbike up by the rear wheel for 3 seconds.

Final steps

- Remove the motorcycle from the lift stand. (📖 p. 43)

8.3 Starting off

i Info

The plug-in stand must be removed before riding.

- Open the throttle carefully.

8.4 Riding

i Info

If unusual noises occur while riding, stop immediately, switch off the engine and contact an authorized KTM workshop.

- If the choke function has been activated, deactivate it after the engine has warmed up.
- After reaching maximum speed by fully opening the throttle grip, turn the throttle back so it is ¾ open. This will barely reduce the speed, but fuel consumption will be considerably lower.
- Your child should always open the throttle only as much as the engine can handle – abruptly opening the throttle increases fuel consumption.
- Your child should switch off the engine if prolonged operation at idle speed or while stationary is imminent.

Guideline

≥ 2 min

8.5 Braking



Warning

Danger of accidents Excessively forceful application of the brakes blocks the wheels.

- Explain to your child that he or she must adapt the braking to the traffic situation and the road conditions.



Warning

Danger of accidents A spongy pressure point on the front or rear brake reduces braking efficiency.

- Check the brake system and do not allow your child to continue riding until the problem is eliminated. (Your authorized KTM workshop will be glad to help.)



Warning

Danger of accidents Moisture and dirt impair the brake system.

- Explain to your child that he or she must brake carefully several times to dry out and remove dirt from the brake linings and the brake discs.

- On sandy, wet, or slippery surfaces, use mostly the rear brake if possible.
- Try to complete the braking procedure before riding into a curve.



8.6 Stopping, parking



Warning

Risk of injury People who act without authorization may not be familiar with the vehicle.

- Do not leave the vehicle unattended if the engine is running.
- Protect the vehicle against access by unauthorized persons.



Warning

Danger of burns Some vehicle components become hot when the vehicle is operated.

- Do not touch any parts such as the exhaust system, radiator, engine, damper, or brake system before the vehicle parts have cooled down.
- Let the vehicle parts cool down before you perform any work on the vehicle.

Note

Material damage The vehicle may be damaged by incorrect procedure when parking.

Significant damage may be caused if the vehicle rolls away or falls over.

The components for parking the vehicle are designed only for the weight of the vehicle.

- Park the vehicle on a firm and level surface.
- Ensure that nobody sits on the vehicle when the vehicle is parked on a stand.

Note

Fire hazard Hot vehicle components pose a fire hazard and explosion risk.

- Do not park the vehicle near to materials which are highly flammable or explosive.
- Allow the vehicle to cool down before covering it.

- Apply the brakes on the motorcycle.
- Press and hold the stop button  while the engine is idling until the engine stops.
- Turn the knurled screw on the fuel tap all the way clockwise.
- Park the motorcycle on firm ground.



8.7 Transporting

Note

Material damage The vehicle may be damaged by incorrect procedure when parking.

Significant damage may be caused if the vehicle rolls away or falls over.

The components for parking the vehicle are designed only for the weight of the vehicle.

- Park the vehicle on a firm and level surface.
- Ensure that nobody sits on the vehicle when the vehicle is parked on a stand.

Note

Fire hazard Hot vehicle components pose a fire hazard and explosion risk.

- Do not park the vehicle near to materials which are highly flammable or explosive.
- Allow the vehicle to cool down before covering it.

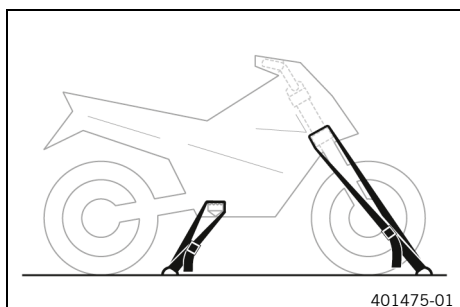

- Switch off the engine.
- Use tension belts or other suitable devices to secure the motorcycle against falling over or rolling away.

8.8 Refueling



Danger

Fire hazard Fuel is highly flammable.

The fuel in the fuel tank expands when warm and can escape if overfilled.

- Do not fuel the vehicle in the vicinity of open flames or lit cigarettes.
- Switch off the engine for refueling.
- Make sure that no fuel is spilled; particularly not on hot parts of the vehicle.
- If any fuel is spilled, wipe it off immediately.
- Observe the specifications for refueling.



Warning

Danger of poisoning Fuel is harmful to health.

- Avoid skin, eye and clothing contact with fuel.
- Immediately consult a doctor if you swallow fuel.
- Do not inhale fuel vapors.
- Rinse the affected area immediately with plenty of water in the event of contact with the skin.
- Rinse the eyes thoroughly with water, and consult a doctor in case of fuel contact with the eyes.
- Change your clothing if fuel spills on them.



Note

Environmental hazard Improper handling of fuel is a danger to the environment.

- Do not allow fuel to enter the groundwater, the soil, or the sewage system.

- Switch off the engine.
- Open the fuel tank filler cap. (📖 p. 14)

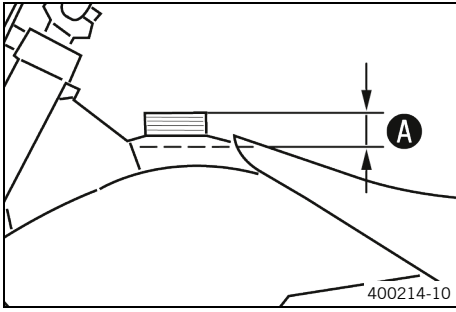

- Fill the fuel tank with fuel up to a maximum of level **A**.

Guideline

Dimension A	35 mm (1.38 in)	
Fuel tank capacity, approx.	2.3 l (2.4 qt.)	Super unleaded (95 octane) mixed with 2-stroke engine oil (1:60) (📖 p. 126)

- Close the fuel tank filler cap. (📖 p. 15)



9 SERVICE SCHEDULE

9.1 Additional information

Any further work that results from the service work must be ordered separately and invoiced separately. Different service intervals may apply in your country, depending on the local operating conditions. Individual service intervals and scopes may change in the course of technical developments. The most up-to-date service schedule is available for authorized KTM dealers for the electronic proof of service. Your authorized KTM dealer will be happy to advise you.

9.2 Service schedule

	every 24 months				
	Every 90 operating hours				
	Every 45 operating hours				
	Every 15 operating hours				
	After 1 operating hour				
Check that the brake linings of the front brake are secured. (📖 p. 74)	○	●	●	●	●
Check that the brake linings of the rear brake are secured. (📖 p. 81)	○	●	●	●	●
Check the brake discs. (📖 p. 71)	○	●	●	●	●
Check the brake lines for damage and tightness.	○	●	●	●	●
Check the front brake fluid level. (📖 p. 72)	○	●	●		
Change the front brake fluid. 🛠️				●	●
Check the rear brake fluid level. (📖 p. 79)	○	●	●		
Change the rear brake fluid. 🛠️				●	●
Check the play of the handbrake lever. (📖 p. 71)	○	●	●	●	●
Check the free travel of the foot brake lever. (📖 p. 78)	○	●	●	●	●
Check the idle speed. 🛠️	○	●	●	●	●
Change the gear oil. 🛠️ (📖 p. 103)	○	●	●	●	●
Check all hoses (e.g. fuel, cooling, bleeder, drainage hoses, etc.) and sleeves for cracking, tightness, and correct routing. 🛠️	○	●	●	●	●
Check the cables for damage and that there are no kinks in the routing. 🛠️	○	●	●	●	●
Check that the throttle cables are undamaged, routed without kinks, and set correctly.	○	●	●	●	●
Check the frame. 🛠️ (📖 p. 69)		●	●	●	
Check the link fork. 🛠️ (📖 p. 69)		●	●	●	
Check the fork bearing for play. 🛠️		●	●	●	
Check the shock absorber heim joint for play. 🛠️		●	●	●	
Check the tire condition. (📖 p. 88)	○	●	●	●	●
Check tire pressure. (📖 p. 89)	○	●	●	●	●
Check the wheel bearing for play. 🛠️		●	●	●	
Check the wheel hubs. 🛠️		●	●	●	
Check the rim run-out. 🛠️	○	●	●	●	
Check the spoke tension. (📖 p. 89)	○	●	●	●	
Check the chain, rear sprocket, engine sprocket, and chain guide. (📖 p. 66)	○	●	●	●	
Check the chain tension. (📖 p. 65)	○	●	●	●	●
Grease all moving parts (e.g., hand lever, chain, etc.) and check for smooth operation. 🛠️	○	●	●	●	●
Change the spark plug and spark plug connector. 🛠️		●	●	●	
Clean the air filter and air filter box. 🛠️ (📖 p. 61)	○	●	●	●	●
Change the rock wool on the main silencer. 🛠️ (📖 p. 62)			●	●	
Service the fork. 🛠️			●	●	

					every 24 months
				Every 90 operating hours	
				Every 45 operating hours	
				Every 15 operating hours	
				After 1 operating hour	
Perform the shock absorber service. 🛠️				•	•
Check all screws, nuts, and hose clips for a tight fit. 🛠️	○	•	•	•	•
Check the clutch setting. 🛠️ (📖 p. 98)		•	•	•	
Check the antifreeze and coolant level. (📖 p. 91)	○	•	•	•	
Change the coolant. 🛠️ (📖 p. 94)					•
Check the steering head bearing play. (📖 p. 50)	○	•			
Lubricate the steering head bearing. 🛠️ (📖 p. 51)			•	•	•
Check/set the carburetor components. 🛠️			•	•	•
Check the cylinder and piston. 🛠️		•	•	•	
Perform minor engine service. (Check the clutch. Check the inlet membrane. Change the piston.) 🛠️			•	•	
Perform major engine service including removing and installing the engine. (Change the connecting rod, conrod bearing, and crank pin. Check the transmission. Change the crankshaft bearing. Change the intake flange. Change all engine bearings.) 🛠️					•
Final check: check the operating safety of the vehicle and take for a test ride. 🛠️	○	•	•	•	•
Enter electronic proof of service in the dealer portal. 🛠️	○	•	•	•	•

- One-time interval
- Periodic interval

10.1 Checking the basic chassis setting with rider's weight

i Info

When adjusting the basic chassis setting, first adjust the shock absorber and then the fork.

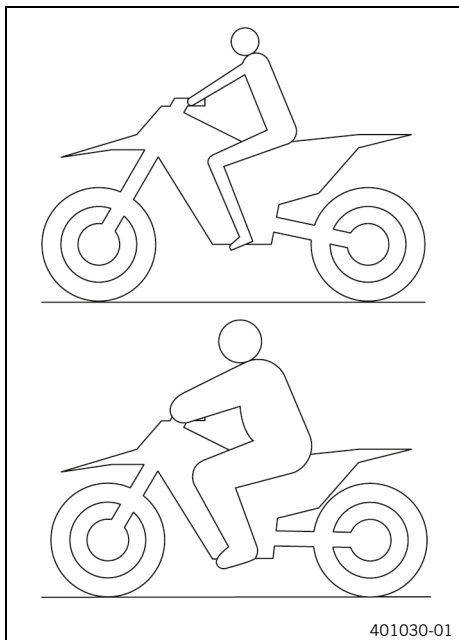

- For optimal motorcycle riding characteristics and to avoid damage to forks, shock absorbers, link fork and frame, the basic settings of the suspension components must match the rider's weight.
- This vehicle is delivered pre-set for a standard rider's weight (with full protective clothing).

Guideline

Standard rider weight	25 ... 35 kg (55 ... 77 lb.)
-----------------------	------------------------------

- If the rider's weight is above or below this range, the basic setting of the suspension components must be adjusted accordingly.
- Small weight differences can be compensated by adjusting the spring preload, but in the case of large weight differences, the springs must be replaced.

10.2 Air suspension XACT 5235

Air suspension **WP XACT 5235** is used in the fork.

In this system, suspension is located in the left fork leg and damping in the right fork leg.

As fork springs are no longer required, a significant weight advantage is achieved when compared to conventional forks. The response on slightly uneven surfaces is significantly improved.

In normal driving mode, suspension is provided exclusively by an air cushion. A steel spring is located in the left fork leg as an end stop.

i Info

If the fork is frequently overloaded, then the air pressure in the fork must be increased to avoid damage to the fork and frame.

The air pressure in the fork can be quickly adjusted to the rider's weight, surface conditions and the rider's preference using a fork airpump. The fork does not have to be dismantled. The time consuming mounting of harder or softer fork springs is not required.

If the air chamber loses air due to a damaged seal, the fork will still not sag. In this case the air is retained in the fork. The suspension travel is maintained as far as possible. The damping becomes harder and the riding comfort reduces.

The rebound damping can be adjusted.

The rebound adjustment is located at the upper end of the right fork leg.

10.3 Compression damping of the shock absorber

The compression damping of the shock absorber is divided into two ranges: high-speed and low-speed. High-speed and low-speed refer to the compression speed of the rear wheel suspension and not to the vehicle speed. The high-speed compression adjuster has an effect, for example, when landing after a jump: the rear wheel suspension compresses quickly. The low-speed compression adjuster has an effect, for example, when riding over long ground swells: the rear wheel suspension compresses slowly. These two ranges can be adjusted separately, although the transition between high-speed and low-speed is gradual. Thus, modifications in the high-speed range affect the compression damping in the low-speed range and vice versa.

10.4 Adjusting the low-speed compression damping of the shock absorber



Caution

Risk of injury Parts of the shock absorber will move around if the shock absorber is detached incorrectly. The shock absorber is filled with highly compressed nitrogen.
 – Please follow the description provided. (Your authorized KTM workshop will be glad to help.)



Info

The effect of the low-speed compression adjuster can be seen in slow to normal compression of the shock absorber.

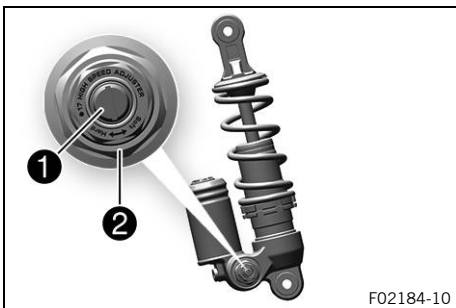

F02184-10

- Turn adjusting screw ① clockwise with a screwdriver as far as the last perceptible click.



Info

Do not loosen fitting ②!

- Turn counterclockwise by the number of clicks corresponding to the shock absorber type.

Guideline

Low-speed compression damping	
Comfort	18 clicks
Standard	15 clicks
Sport	12 clicks



Info

Turn clockwise to increase damping; turn counterclockwise to reduce damping.



10.5 Adjusting the high-speed compression damping of the shock absorber



Caution

Risk of injury Parts of the shock absorber will move around if the shock absorber is detached incorrectly.

The shock absorber is filled with highly compressed nitrogen.

- Please follow the description provided. (Your authorized KTM workshop will be glad to help.)



Info

The effect of the high speed compression adjuster can be seen in the fast compression of the shock absorber.

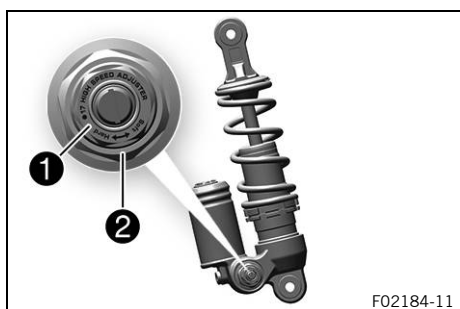

- Push the splash protector to the side.
- Using an open end wrench, turn adjusting screw ❶ clockwise all the way.



Info

Do not loosen fitting ❷!

- Turn counterclockwise by the number of turns corresponding to the shock absorber type.

Guideline

High-speed compression damping	
Comfort	2.5 turns
Standard	2 turns
Sport	1.5 turns



Info

Turn clockwise to increase damping; turn counterclockwise to reduce damping.

- Position the splash protector.

10.6 Adjusting the rebound damping of the shock absorber



Caution

Risk of injury Parts of the shock absorber will move around if the shock absorber is detached incorrectly.

The shock absorber is filled with highly compressed nitrogen.

- Please follow the description provided. (Your authorized KTM workshop will be glad to help.)

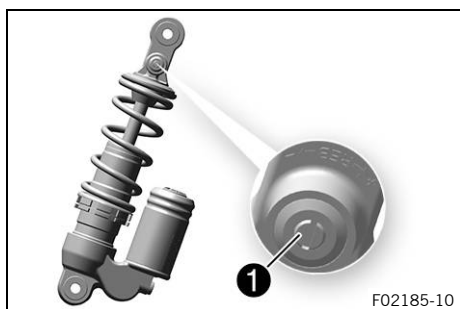

- Turn adjusting screw ❶ clockwise up to the last perceptible click.
- Turn counterclockwise by the number of clicks corresponding to the shock absorber type.

Guideline

Rebound damping	
Comfort	18 clicks
Standard	15 clicks
Sport	12 clicks



Info

Turn clockwise to increase the damping; turn counter-clockwise to reduce damping when the shock absorber rebounds.



10.7 Measuring the dimension of the rear wheel unloaded

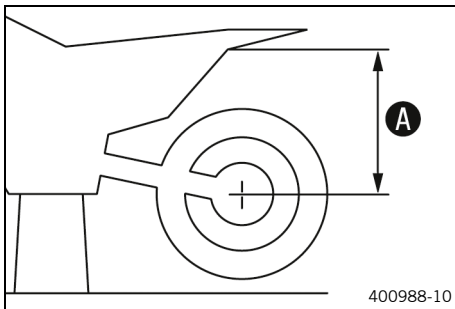

Preparatory work

- Raise the motorcycle with a lift stand. (📖 p. 43)

Main work

- Measure the vertical distance between the rear axle and a fixed point, such as a marking on the side cover.
- Note the value as dimension **A**.

Finishing work

- Remove the motorcycle from the lift stand. (📖 p. 43)



10.8 Checking the static sag of the shock absorber

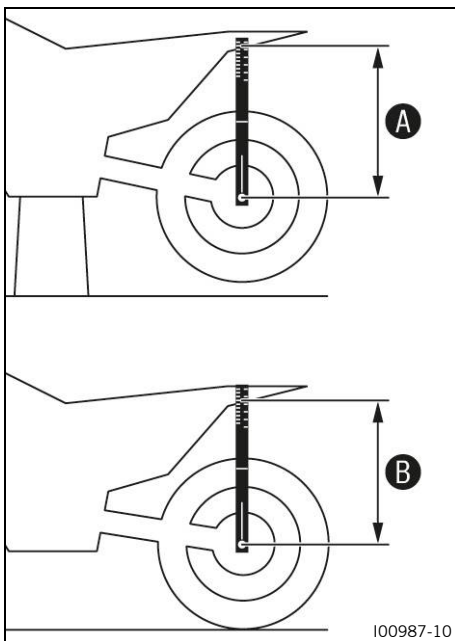

- Measure dimension **A** of rear wheel unloaded. (📖 p. 31)
- Hold the motorcycle upright with aid of an assistant.
- Measure the distance between rear axle and fixed point again.
- Note the value as dimension **B**.



Info

The static sag is the difference between measurements **A** and **B**.

- Check the static sag.

Static sag	30 mm (1.18 in)
------------	-----------------

- » If the static sag is less or more than the specified value:
 - Adjust the spring preload of the shock absorber. (📖 p. 32)



10.9 Checking the rider sag of the shock absorber

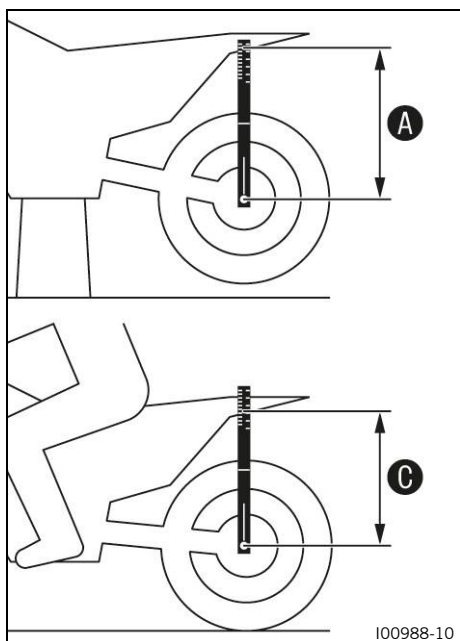

- Measure dimension **A** of rear wheel unloaded. (📖 p. 31)
- With another person holding the motorcycle, the rider, wearing full protective clothing, sits on the seat in a normal sitting position (feet on footrests) and bounces up and down a few times.
 - ✓ The rear wheel suspension levels out.
- Another person now measures the distance between the rear axle and the fixed point.
- Note the value as dimension **C**.

i Info
The rider sag is the difference between measurements **A** and **C**.

- Check the rider sag.

Rider sag	80 mm (3.15 in)
-----------	-----------------

- » If the rider sag differs from the specified measurement:
 - Adjust the rider sag. 🛠️ (📖 p. 33)

10.10 Adjusting the spring preload of the shock absorber 🛠️



Caution

Risk of injury Parts of the shock absorber will move around if the shock absorber is detached incorrectly.

The shock absorber is filled with highly compressed nitrogen.

- Please follow the description provided. (Your authorized KTM workshop will be glad to help.)

Preparatory work

- Raise the motorcycle with a lift stand. (📖 p. 43)
- Remove the shock absorber. 🛠️ (📖 p. 58)
- After removing the shock absorber, clean it thoroughly.

Main work

- Measure the full spring length while it is under tension and note down the value.
- Loosen retaining ring **1**.
- Turn adjusting ring **2** until the spring is no longer under tension.

Hook wrench (T304)
Hook wrench (T1533)

i Info
If the spring cannot be fully released, the spring must be removed to accurately measure the spring length.

- Measure the total spring length while the spring is not under tension.
- Tighten the spring to the specified measurement by turning adjusting ring **2**.

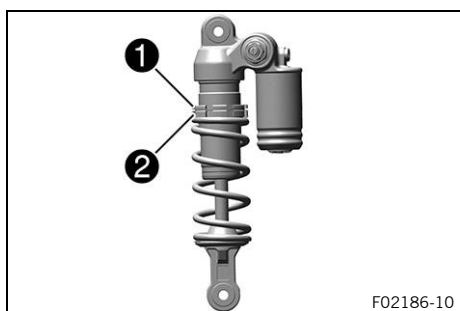

Guideline

Spring preload	5 mm (0.2 in)
----------------	---------------



Info

The spring preload is the difference between the relaxed spring length and the tensioned spring length. Depending on the static sag and/or the rider sag, it may be necessary to increase or decrease the spring preload.

- Tighten retaining ring ①.

Finishing work

- Install the shock absorber. 🛠️ (📖 p. 58)
- Remove the motorcycle from the lift stand. (📖 p. 43)



10.11 Adjusting the riding sag 🛠️

Preparatory work

- Raise the motorcycle with a lift stand. (📖 p. 43)
- Remove the shock absorber. 🛠️ (📖 p. 58)
- After removing the shock absorber, clean it thoroughly.

Main work

- Select and mount a suitable spring.

Guideline

Spring rate	
Weight of rider: 15 ... 25 kg (33 ... 55 lb.)	25 N/mm (143 lb/in)
Weight of rider (standard): 25 ... 35 kg (55 ... 77 lb.)	30 N/mm (171 lb/in)
Weight of rider: 35 ... 45 kg (77 ... 99 lb.)	35 N/mm (200 lb/in)



Info

The spring rate is shown on the outside of the spring. Smaller weight differences can be compensated by changing the spring preload.

Finishing work

- Install the shock absorber. 🛠️ (📖 p. 58)
- Remove the motorcycle from the lift stand. (📖 p. 43)
- Check the static sag of the shock absorber. (📖 p. 31)
- Check the rider sag of the shock absorber. (📖 p. 32)
- Adjust the rebound damping of the shock absorber. (📖 p. 30)

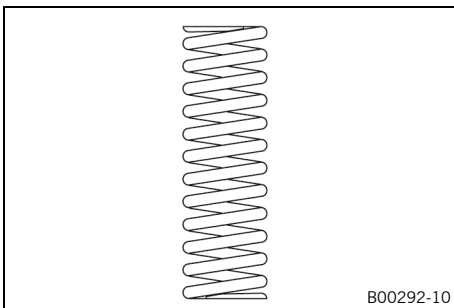

10.12 Checking the basic setting of the fork

i Info

For various reasons, no exact rider sag can be determined for the fork.

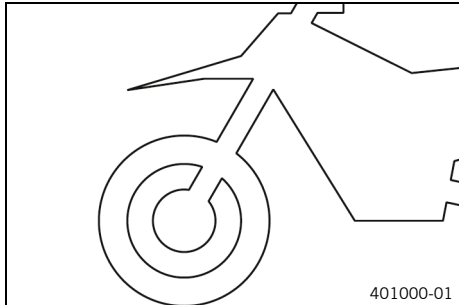

- Smaller differences in the rider's weight can be compensated for by the fork air pressure.
- However, if the fork frequently bottoms out (hard end stop on compression), the fork air pressure must be increased, within the specified values, to avoid damage to the fork and frame.

10.13 Adjusting the fork air pressure



Warning

Danger of accidents Modifications to the suspension setting may seriously alter the handling characteristic.

Modifications which are not coordinated with others to the suspension setting may cause a serious deterioration in the handling characteristic and overload components.

- Only make adjustments within the recommended range.
- Make sure your child rides slowly to start with after making adjustments in order that he or she can assess the new handling characteristic.

i Info

Check or adjust the air pressure under the same conditions at the earliest 5 minutes after switching off the engine.

The air suspension is located in the left fork leg. The rebound damping is located in the right fork leg.

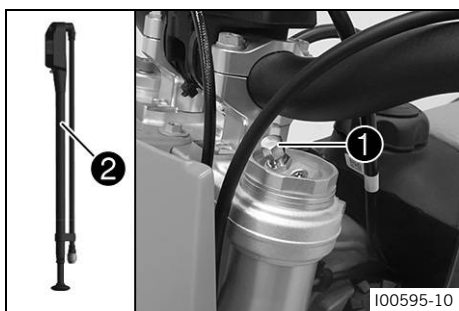

Preparatory work

- Raise the motorcycle with a lift stand. (📖 p. 43)

Main work

- Remove protection cap ①.
- Push together fork airpump ② fully.

Fork airpump (79412966100)



Info

The fork airpump is included as part of the motorcycle's accessory pack.

- Connect the fork airpump to the left fork leg.
 - ✓ The fork airpump indicator switches on automatically.
 - ✓ A little air escapes from the fork leg when connecting.

i Info
 This is due to the volume of the hose and not due to a defect in the fork airpump or the fork.
 Read the accompanying **KTM PowerParts** instructions.

- Adjust the air pressure as specified.

Guideline

Air pressure	1 bar (15 psi)
Gradual changing of the air pressure in steps of	0.2 bar (3 psi)
Minimum air pressure	0.5 bar (7 psi)
Maximum air pressure	5 bar (73 psi)

i Info
 Never adjust the air pressure to a value outside the stated range.

- Disconnect the fork airpump from the left fork leg.
 - ✓ When disconnecting, excess pressure will escape from the hose – the fork leg itself does not lose any air.
 - ✓ The fork airpump indicator switches off automatically after 80 seconds.
- Mount the protection cap.

i Info
 Only mount the protection cap by hand.

Finishing work

- Remove the motorcycle from the lift stand. (📖 p. 43)



10.14 Adjusting the rebound damping of the fork

i Info
 The hydraulic rebound damping determines the fork suspension behavior.



- Turn adjuster ① clockwise all the way to the stop.

i Info
 Adjuster ① is located at the upper end of the right fork leg.

- Turn counterclockwise by the number of clicks corresponding to the fork type.

Guideline

Rebound damping	
Comfort	15 clicks
Standard	12 clicks
Sport	10 clicks

i Info

Turn clockwise to increase the damping; turn counter-clockwise to reduce damping when the shock absorber rebounds.

10.15 Handlebar position

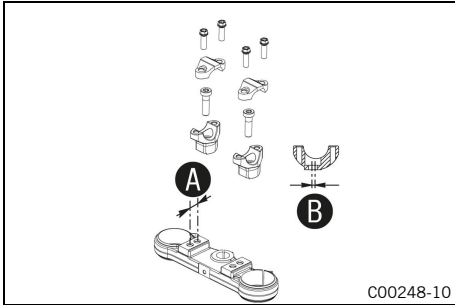

On the upper triple clamp, there are 2 holes at a distance of **A** to each other.

Hole distance A	16 mm (0.63 in)
------------------------	-----------------

The holes on the handlebar supports are placed at a distance of **B** from the center.

Hole distance B	3.5 mm (0.138 in)
------------------------	-------------------

The handlebar supports can be mounted in four different positions. This allows the handlebar to be mounted in the most comfortable position for the rider.

10.16 Adjusting the handlebar position



Warning

Danger of accidents A repaired handlebar poses a safety risk.

If the handlebar is bent or straightened, the material becomes fatigued. The handlebar may break as a result.

- Change the handlebar if the handlebar is damaged or bent.

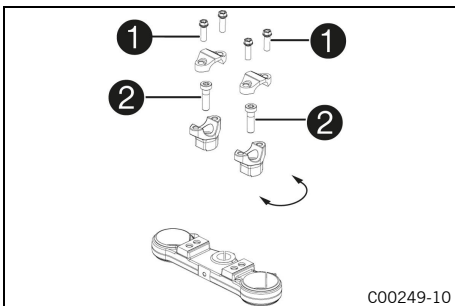

- Remove screws **1**. Take off the handlebar clamps. Remove the handlebar and lay it to one side.

i Info

Cover the components to protect them against damage. Do not kink the cables and lines.

- Remove screws **2**. Take off handlebar supports.
- Place handlebar supports in required position. Mount and tighten screws **2**.

Guideline

Screw, handlebar support	M10	40 Nm (29.5 lbf ft) Loctite®243™
--------------------------	-----	--

- Position the handlebar.

i Info

Make sure the cables and wiring are positioned correctly.

- Position the handlebar clamps. Mount screws **1** and tighten evenly.

Guideline

Screw, handlebar clamp	M8	20 Nm (14.8 lbf ft)
------------------------	----	---------------------



Info

Make sure the installed gaps are even.



11.1 Seat height adjustment options

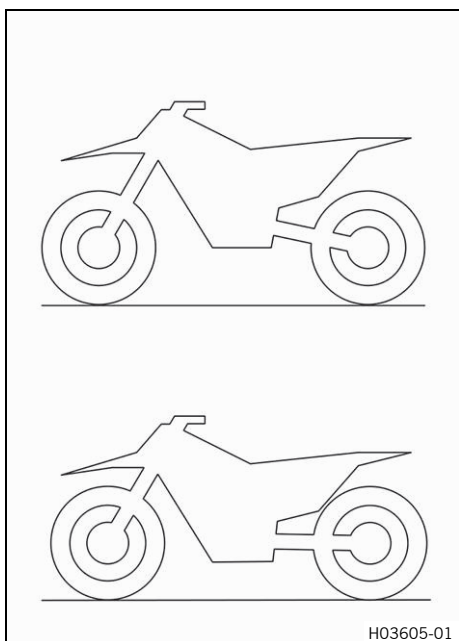

This vehicle offers several options for adjusting the seat height to the rider's height.

The seat height can be changed with the mounting position of the fork, shock absorber, and frame.

i Info

When adjusting the seat height on the fork and shock absorber, make sure that the vehicle is as straight as possible after completing the work.

If the seat height on the shock absorber is set low, the fork should be pushed through further and vice versa.

11.2 Adjusting the seat height on the shock absorber



Warning

Danger of accidents Modifications to the suspension setting may seriously alter the handling characteristic.

- Make sure your child rides slowly to start with after making adjustments in order that he or she can assess the new handling characteristic.

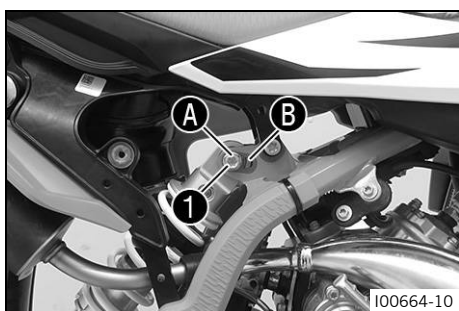

Preparatory work

- Raise the motorcycle with a lift stand. (🛠️ p. 43)

Main work

- Hold the rear wheel with the link fork and remove screw **1**.
- Position the shock absorber according to the required seat height.

Guideline

High seat position	A
Low seat position	B

- Mount and tighten screw **1**.

Guideline

Screw, top shock absorber	M10	45 Nm (33.2 lbf ft) Loctite®243™
---------------------------	-----	--

Finishing work

- Remove the motorcycle from the lift stand. (🛠️ p. 43)

11.3 Adjusting the seat height on the fork 🛠️



Warning

Danger of accidents Modifications to the suspension setting may seriously alter the handling characteristic.

- Make sure your child rides slowly to start with after making adjustments in order that he or she can assess the new handling characteristic.



Info

The seat height can be infinitely adjusted by pushing the fork legs through.
If the seat height is adjusted on the fork, the seat height should also be adjusted on the shock absorber.

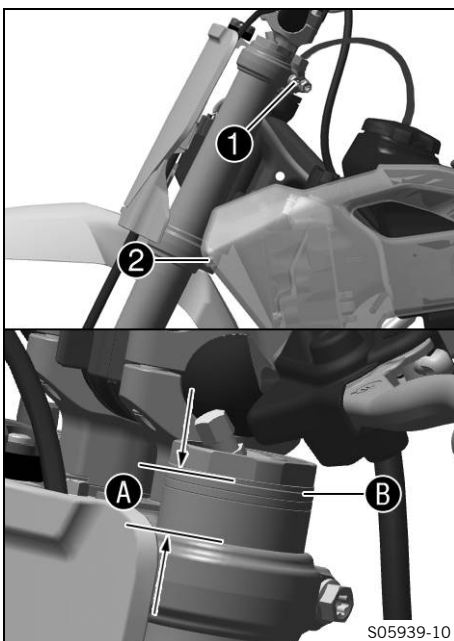

Preparatory work

- Raise the motorcycle with a lift stand. (📖 p. 43)
- Remove the front wheel. 🛠️ (📖 p. 85)

Main work

- Loosen screw ①.
- Loosen screw ②.
- Position the fork leg according to the required seat height.

Guideline

Condition

Seat position as low as possible, fork fully inserted

Maximum distance A between lower edge of screw cap and upper edge of triple clamp	18 mm (0.71 in)
---	-----------------

Condition

Seat position as high as possible, fork pulled out completely

Bottom edge of screw cap B closes flush with the upper edge of the triple clamp
--

Position the fork leg only within the described range.
--

- Tighten screw ②.

Guideline

Screw, bottom triple clamp	M8	15 Nm (11.1 lbf ft)
-------------------------------	----	---------------------

- Tighten screw ①.

Guideline

Screw, top triple clamp	M8	20 Nm (14.8 lbf ft)
----------------------------	----	---------------------

- Repeat the procedure on the other fork leg.

Guideline

Position both fork legs equally.

Finishing work

- Install the front wheel. 🛠️ (📖 p. 85)

11.4 Adjusting the seat height on the frame 🛠️

Preparatory work

- Remove the seat. (📖 p. 59)
- Turn the knurled screw on the fuel tap all the way clockwise.
- Remove the fuel tank. 🛠️ (📖 p. 51)
- Remove the right side cover. (📖 p. 56)
- Remove main silencer. (📖 p. 61)

Main work

- Loosen hose clip ❶.

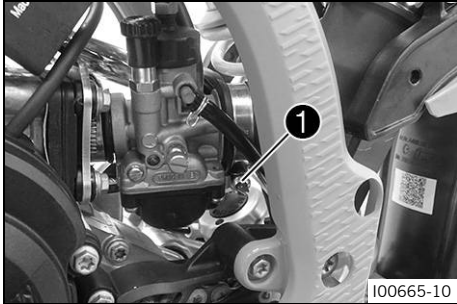

- Remove screws ❷ on the right and left side.
- Remove subframe with air filter box.

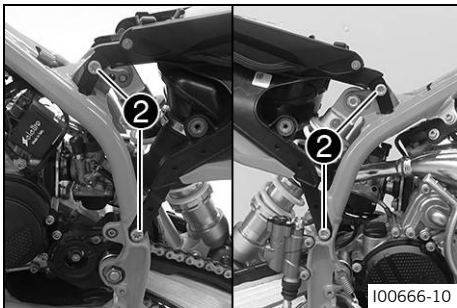

- Loosen hose clip ❸ and slide the intake snorkel to the desired position.

Guideline

High seat position	Position A
Low seat position	Position B

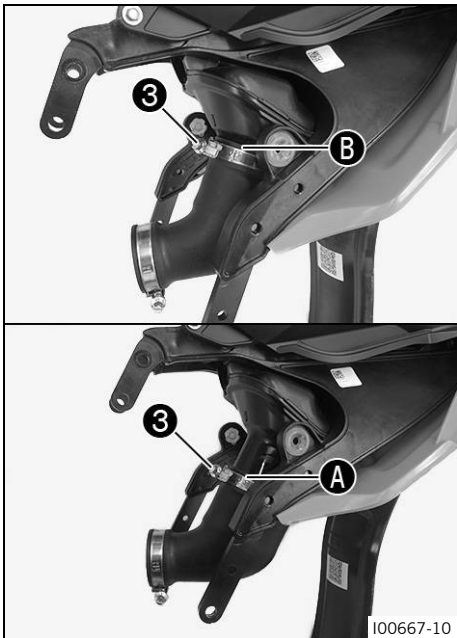

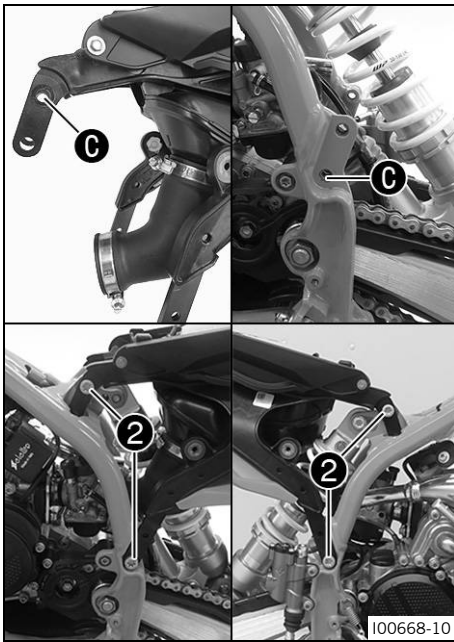

Condition

Low seat position

- Position subframe in position **C** with screws **2** on the right and left side and tighten.

Guideline

Screw, tail assembly	M8	30 Nm (22.1 lbf ft) Loctite®243™
----------------------	----	--

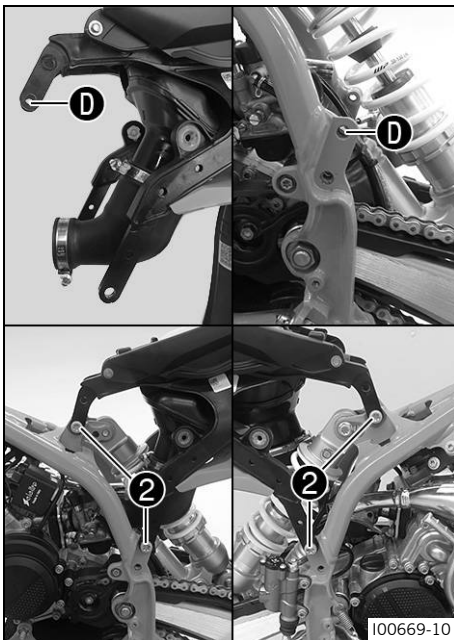

Condition

High seat position

- Position subframe in position **D** with screws **2** on the right and left side and tighten.

Guideline

Screw, tail assembly	M8	30 Nm (22.1 lbf ft) Loctite®243™
----------------------	----	--

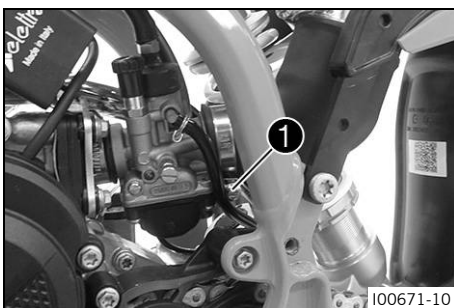

- Position the intake flange on the carburetor and tighten hose clip **1**.

Guideline

Hose clip, carburetor	-	2.8 Nm (2.07 lbf ft)
-----------------------	---	-------------------------

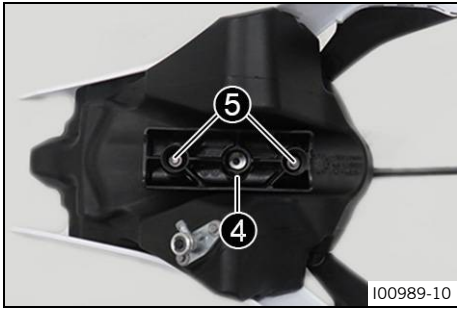

Condition

Low seat position

- Make sure that tank extension ④ is removed.

Condition

High seat position

- Make sure that tank extension ④ is fitted to the fuel tank using screws ⑤ supplied.

Guideline

Tank extension screw	EJOT	2 Nm (1.5 lbf ft)
----------------------	-------------	-------------------

- Install the fuel tank. 🛠️ (📖 p. 52)
- Attach the throttle cable wire to the top tube in the area ① with a cable tie.

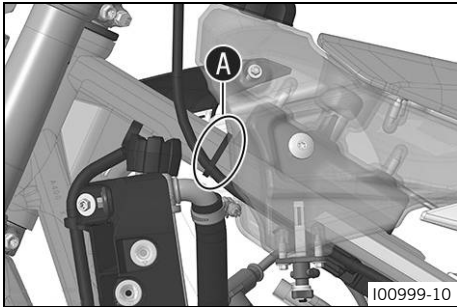

Finishing work

- Install the main silencer. (📖 p. 62)
- Install the right side cover. (📖 p. 57)
- Install the fuel tank. 🛠️ (📖 p. 52)
- Mount the seat. (📖 p. 59)

12.1 Raising the motorcycle with a lift stand

Note

Danger of damage The parked vehicle can roll away or fall over.

- Park the vehicle on a firm and level surface.

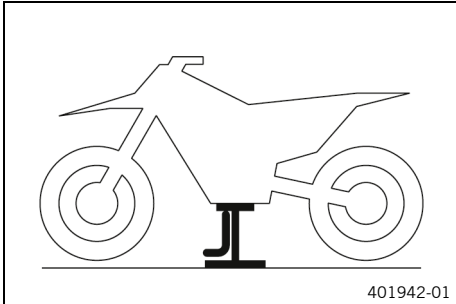

- Raise the motorcycle at the frame underneath the engine.

Lift stand (78929955100)

- ✓ Neither wheel is in contact with the ground.
- Secure the motorcycle against falling over.



12.2 Removing the motorcycle from the lift stand

Note

Danger of damage The parked vehicle can roll away or fall over.

- Park the vehicle on a firm and level surface.

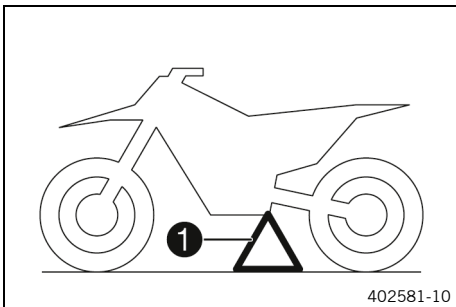

- Remove the motorcycle from the lift stand.
- Remove the lift stand.
- To park the motorcycle, insert plug-in stand ① into the plug-in stand bracket on the left side of the vehicle.



Info

Remove the plug-in stand before riding.



12.3 Bleeding the fork legs

Preparatory work

- Raise the motorcycle with a lift stand. (📖 p. 43)

Main work

- Release bleeder screws ①.
- ✓ Any excess pressure escapes from the interior of the fork.
- Tighten the bleeder screws.

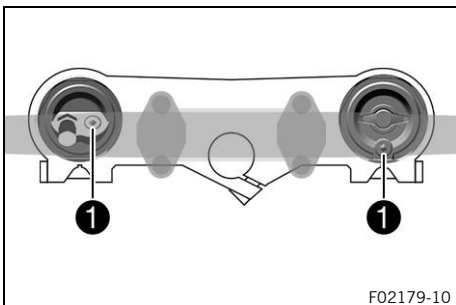

Finishing work

- Remove the motorcycle from the lift stand. (📖 p. 43)



12.4 Cleaning the dust boots of the fork legs

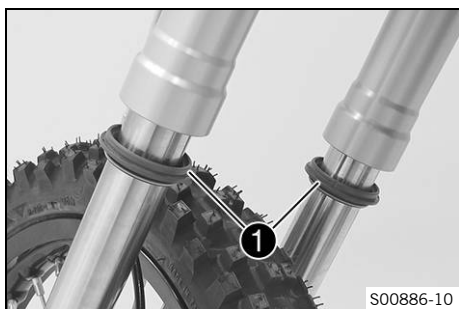

Preparatory work

- Raise the motorcycle with a lift stand. (📖 p. 43)
- Remove the fork protector. (📖 p. 44)

Main work

- Push dust boots ❶ of both fork legs downward.

Info

The dust boots remove dust and coarse dirt particles from the inside fork tubes. Over time, dirt can accumulate behind the dust boots. If this dirt is not removed, the seals rings behind can start to leak.



Warning

Danger of accidents Oil or grease on the brake discs reduces the braking effect.

- Always keep the brake discs free of oil and grease.
- Clean the brake discs with brake cleaner when necessary.

- Clean and oil the dust boots and inside fork tubes of both fork legs.

Universal oil spray (📖 p. 128)

- Press the dust boots back into the installation position.
- Remove the excess oil.

Finishing work

- Install the fork protector. (📖 p. 45)
- Remove the motorcycle from the lift stand. (📖 p. 43)

12.5 Removing the fork protector

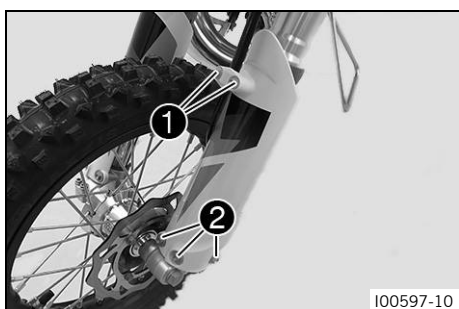

- Remove screws ❶ and take off the clamp.
- Remove screws ❷ on the left fork leg. Take off the fork protector.

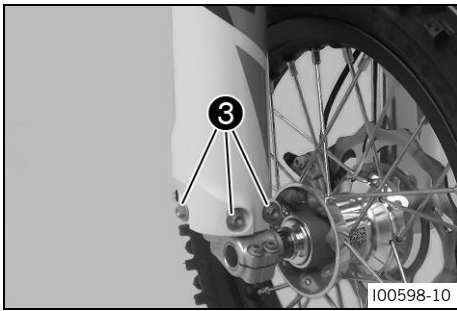

- Remove screws ③ on the right fork leg. Take off the fork protector.



12.6 Installing the fork protector

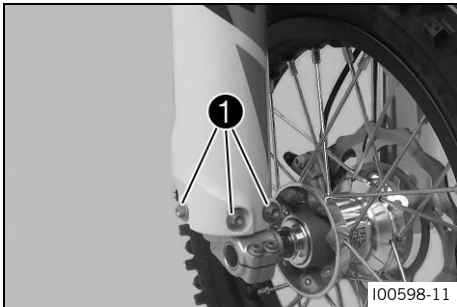

- Position fork protector on the right fork leg. Mount and tighten screws ①.

Guideline

Remaining screws, chassis	M6	10 Nm (7.4 lbf ft)
---------------------------	----	--------------------

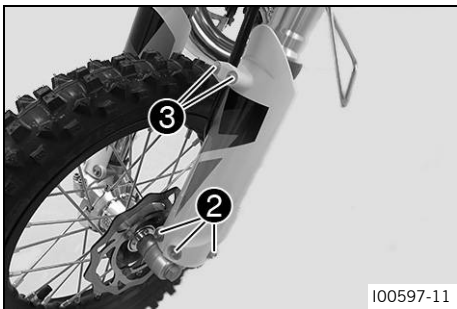

- Position fork protector on left fork leg. Mount and tighten screws ②.

Guideline

Remaining screws, chassis	M6	10 Nm (7.4 lbf ft)
---------------------------	----	--------------------

- Position the brake line and the clamp. Mount and tighten screws ③.

Guideline

Screw, brake line holder	EJOT PT K60x20-Z	2 Nm (1.5 lbf ft)
--------------------------	----------------------------	-------------------



12.7 Removing the fork legs

Preparatory work

- Raise the motorcycle with a lift stand. (📖 p. 43)
- Remove the front wheel. 🛠️ (📖 p. 85)

Main work

- Remove screws ① and take off the clamp.
- Remove screws ② and take off the brake caliper.
- Allow the brake caliper and the brake line to hang loosely to the side.

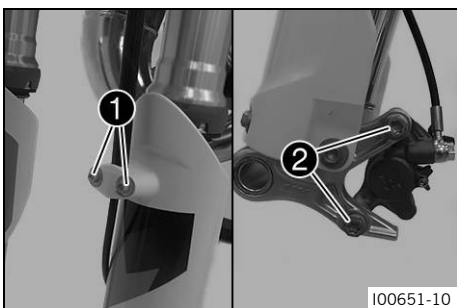

Info

Do not kink the brake line.

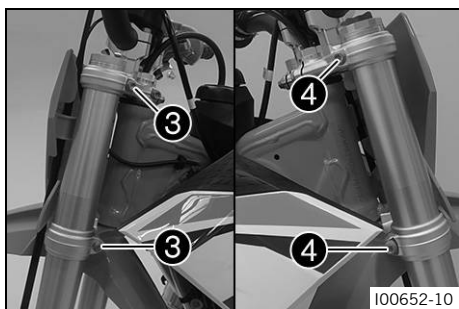

- Loosen screws **3**. Remove the left fork leg.
- Loosen screws **4**. Remove the right fork leg.

12.8 Installing the fork legs

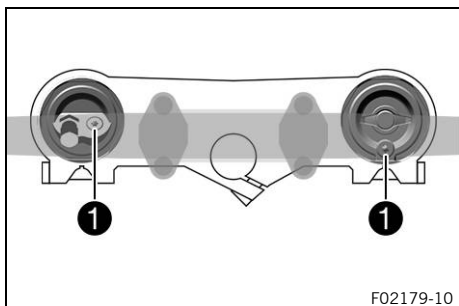

Main work

- Position the fork legs.
- ✓ Bleeder screws **1** are positioned toward the rear.



Info

The second milled groove in the fork leg must be flush with the upper edge of the upper triple clamp.

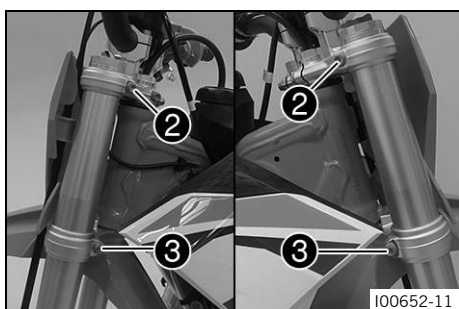

- Tighten screws **2**.

Guideline

Screw, top triple clamp	M8	20 Nm (14.8 lbf ft)
-------------------------	----	---------------------

- Tighten screws **3**.

Guideline

Screw, bottom triple clamp	M8	15 Nm (11.1 lbf ft)
----------------------------	----	---------------------

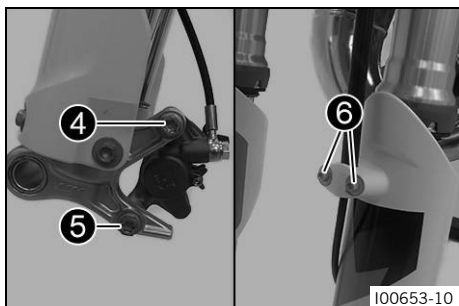

- Position the brake caliper, mount screw **4**, and tighten.

Guideline

Screw, front brake caliper	M8x35	20 Nm (14.8 lbf ft) Loctite®243™
----------------------------	-------	--

- Mount and tighten screw **5**.

Guideline

Screw, front brake caliper	M8x35	20 Nm (14.8 lbf ft) Loctite®243™
----------------------------	-------	--

- Position the brake line and the clamp. Mount and tighten screws **6**.

Guideline

Screw, brake line holder	EJOT PT K60x20-Z	2 Nm (1.5 lbf ft)
--------------------------	----------------------------	-------------------

Finishing work

- Install the front wheel. (🔧 p. 85)

12.9 Removing the lower triple clamp

Preparatory work

- Raise the motorcycle with a lift stand. (p. 43)
- Remove the front wheel. (p. 85)
- Remove the fork legs. (p. 45)
- Remove the start number plate. (p. 54)
- Remove front fender. (p. 55)

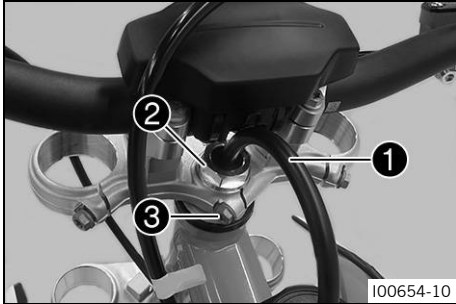

Main work

- Pull fuel tank breather **1** out of the steering stem.
- Remove nut **2**.
- Release screw **3**, take off the upper triple clamp with the handlebar and set aside.



Info

Cover the components to protect them against damage. Do not kink the cables and lines.

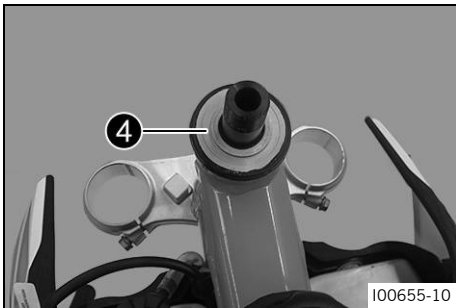

- Remove protective ring **4**.
- Remove the lower triple clamp with the steering stem.
- Remove the upper steering head bearing.



12.10 Installing the lower triple clamp

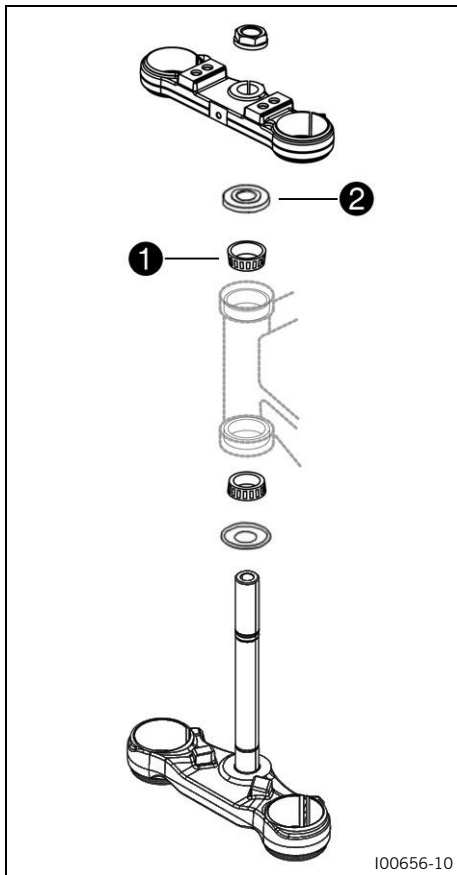

Main work

- Clean the bearing and sealing elements, check for damage, and grease.

High viscosity grease (p. 127)

- Insert the lower triple clamp with the steering stem. Mount upper steering head bearing 1.
- Push on protective ring 2.

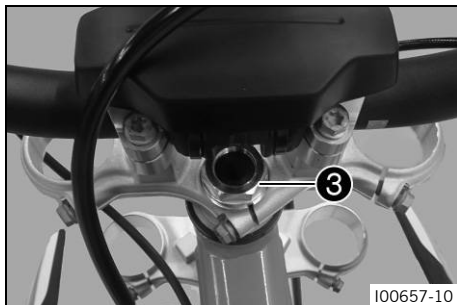

- Position the upper triple clamp and handlebar.
- Mount nut 3, but do not tighten yet.

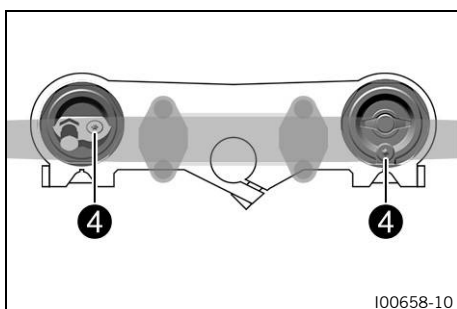

- Position the fork legs.
- ✓ Bleeder screws 4 are positioned toward the rear.

Info

The second milled groove (from the top) must be flush with the upper edge of the upper triple clamp.

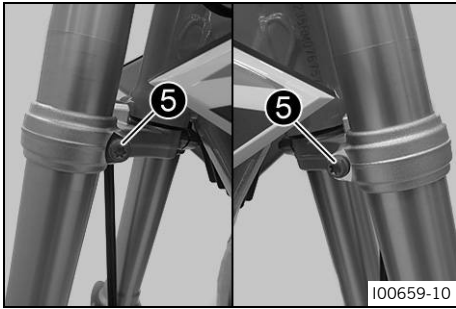

- Tighten screws **5**.

Guideline

Screw, bottom triple clamp	M8	15 Nm (11.1 lbf ft)
----------------------------	----	---------------------

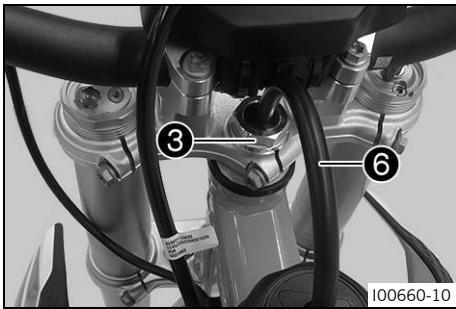

- Tighten nut **3**.

Guideline

Nut, steering head	M20x1.5	10 Nm (7.4 lbf ft)
--------------------	---------	--------------------

- Position the fuel tank breather **6** in the steering stem.

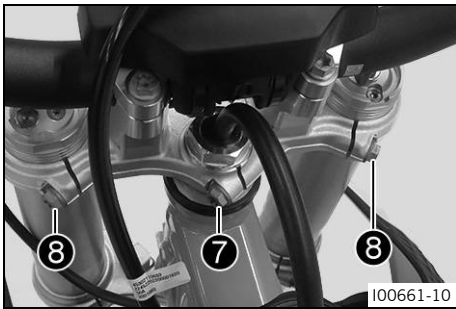

- Tighten bolt **7**.

Guideline

Screw, top triple clamp	M8	20 Nm (14.8 lbf ft)
-------------------------	----	---------------------

- Using a plastic hammer, tap lightly on the upper triple clamp to avoid stresses.

- Tighten screws **8**.

Guideline

Screw, top triple clamp	M8	20 Nm (14.8 lbf ft)
-------------------------	----	---------------------

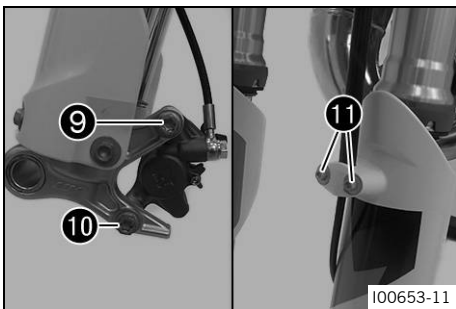

- Position the brake caliper, mount screw **9**, and tighten.

Guideline

Screw, front brake caliper	M8x35	20 Nm (14.8 lbf ft) Loctite®243™
----------------------------	-------	--

- Mount and tighten screw **10**.

Guideline

Screw, front brake caliper	M8x35	20 Nm (14.8 lbf ft) Loctite®243™
----------------------------	-------	--

- Position the brake line and the clamp. Mount and tighten screws **11**.

Guideline

Screw, brake line holder	EJOT PT K60x20-Z	2 Nm (1.5 lbf ft)
--------------------------	----------------------------	-------------------

Finishing work

- Install front fender. (📖 p. 55)
- Install the start number plate. (📖 p. 54)
- Check the wiring harness, cables, and brake and clutch lines for freedom of movement and correct routing.
- Install the front wheel. 🛠️ (📖 p. 85)
- Check the steering head bearing play. (📖 p. 50)

- Remove the motorcycle from the lift stand. (📖 p. 43)

12.11 Checking the steering head bearing play



Warning

Danger of accidents Incorrect steering head bearing play impairs the handling characteristic and damages components.

- Correct incorrect steering head bearing play immediately. (Your authorized KTM workshop will be glad to help.)



Info

If the vehicle is operated for a lengthy period with play in the steering head bearing, the bearings and the bearing seats in the frame can become damaged over time.

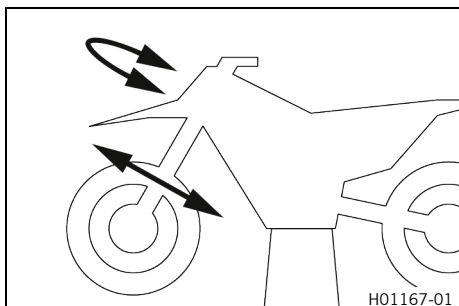

Preparatory work

- Raise the motorcycle with a lift stand. (📖 p. 43)

Main work

- Move the handlebar to the straight-ahead position. Move the fork legs to and fro in the direction of travel.

Play should not be detectable on the steering head bearing.

» If there is detectable play:

- Adjust the steering head bearing play. (📖 p. 50)

- Move the handlebar to and fro over the entire steering range.

It must be possible to move the handlebar easily over the entire steering range. There should be no detectable detent positions.

» If detent positions are detected:

- Adjust the steering head bearing play. (📖 p. 50)
- Check the steering head bearing and replace if required.

Finishing work

- Remove the motorcycle from the lift stand. (📖 p. 43)

12.12 Adjusting the steering head bearing play

Preparatory work

- Raise the motorcycle with a lift stand. (📖 p. 43)

Main work

- Pull fuel tank breather ① out of the steering stem.
- Loosen screws ②.
- Loosen screw ③.
- Loosen and retighten nut ④.

Guideline

Nut, steering head	M20x1.5	10 Nm (7.4 lbf ft)
--------------------	---------	--------------------

- Using a plastic hammer, tap lightly on the upper triple clamp to avoid stresses.

- Tighten screw ③.

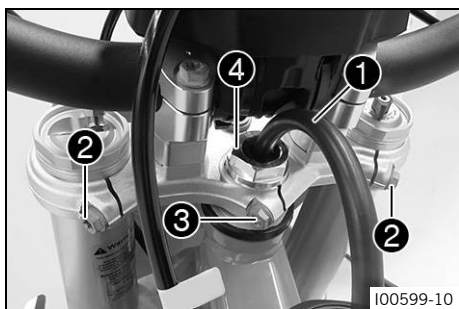

Guideline

Screw, top triple clamp	M8	20 Nm (14.8 lbf ft)
-------------------------	----	---------------------

- Tighten screws ②.

Guideline

Screw, top triple clamp	M8	20 Nm (14.8 lbf ft)
-------------------------	----	---------------------

- Position the fuel tank breather ① in the steering stem.

Finishing work

- Check the steering head bearing play. (📖 p. 50)
- Remove the motorcycle from the lift stand. (📖 p. 43)



12.13 Lubricating the steering head bearing 🛠️

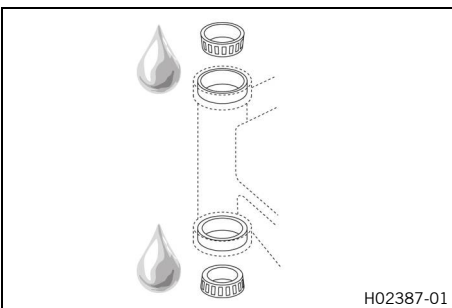

- Remove the lower triple clamp. 🛠️ (📖 p. 47)
- Install the lower triple clamp. 🛠️ (📖 p. 48)

i Info

The steering head bearing is cleaned and lubricated in the course of removal and installation of the lower triple clamp.



12.14 Removing the fuel tank 🛠️



Danger

Fire hazard Fuel is highly flammable.

The fuel in the fuel tank expands when warm and can escape if overfilled.

- Do not fuel the vehicle in the vicinity of open flames or lit cigarettes.
- Switch off the engine for refueling.
- Make sure that no fuel is spilled; particularly not on hot parts of the vehicle.
- If any fuel is spilled, wipe it off immediately.
- Observe the specifications for refueling.



Warning

Danger of poisoning Fuel is harmful to health.

- Avoid skin, eye and clothing contact with fuel.
- Immediately consult a doctor if you swallow fuel.
- Do not inhale fuel vapors.
- Rinse the affected area immediately with plenty of water in the event of contact with the skin.
- Rinse the eyes thoroughly with water, and consult a doctor in case of fuel contact with the eyes.
- Change your clothing if fuel spills on them.
- Keep fuels correctly in a suitable canister, and out of the reach of children.

Preparatory work

- Remove the seat. (📖 p. 59)
- Turn the knurled screw on the fuel tap all the way clockwise.

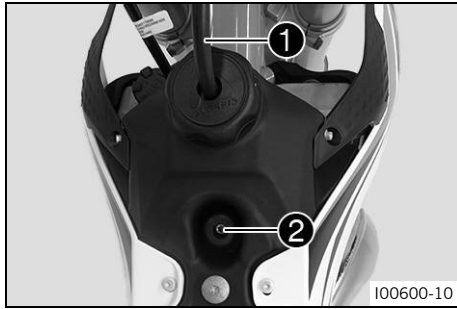

Main work

- Pull fuel tank breather ① out of the steering stem.
- Remove screw ②.



- Pull off fuel hose ③.



Info

Remaining fuel may flow out of the fuel hose.

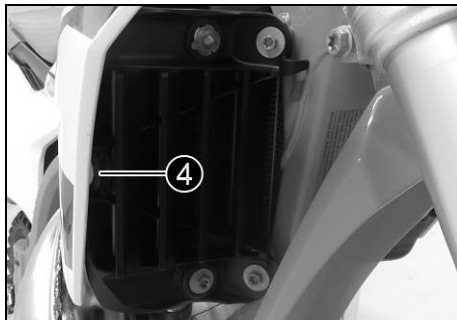

- Pull the fuel tank guard out of rubber bushing ④.
- Raise the fuel tank.
- Take off the fuel tank.

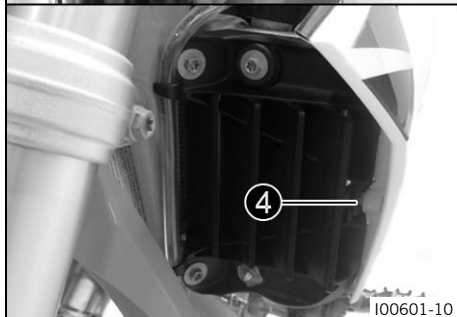

12.15 Installing the fuel tank ↩



Danger

Fire hazard Fuel is highly flammable.

The fuel in the fuel tank expands when warm and can escape if overfilled.

- Do not fuel the vehicle in the vicinity of open flames or lit cigarettes.
- Switch off the engine for refueling.
- Make sure that no fuel is spilled; particularly not on hot parts of the vehicle.
- If any fuel is spilled, wipe it off immediately.
- Observe the specifications for refueling.



Warning

Danger of poisoning Fuel is harmful to health.

- Avoid skin, eye and clothing contact with fuel.
- Immediately consult a doctor if you swallow fuel.
- Do not inhale fuel vapors.
- Rinse the affected area immediately with plenty of water in the event of contact with the skin.
- Rinse the eyes thoroughly with water, and consult a doctor in case of fuel contact with the eyes.
- Change your clothing if fuel spills on them.
- Keep fuels correctly in a suitable canister, and out of the reach of children.

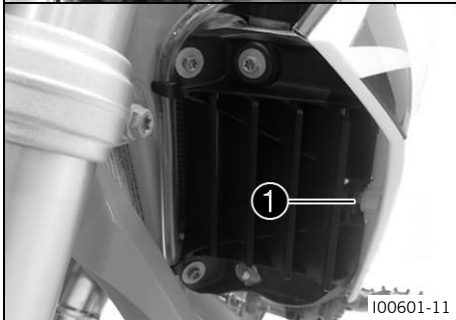
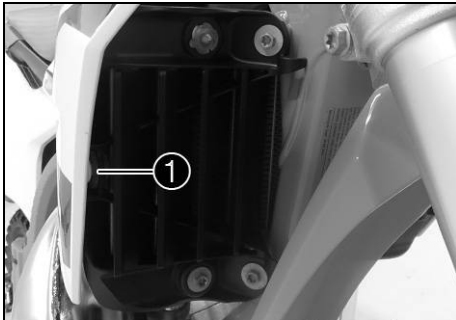

Main work

- Position the fuel tank.
- Make sure that no cables or throttle cables are trapped or damaged.
- Press fuel tank guard into rubber bushing **1**.
- Check the throttle cable routing. (📖 p. 69)

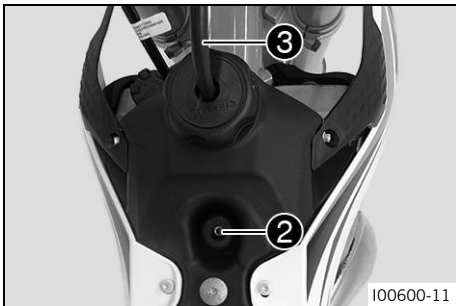

- Mount and tighten screw **2**.

Guideline

Remaining screws, chassis	M6	10 Nm (7.4 lbf ft)
------------------------------	----	--------------------

- Position the fuel tank breather **3** in the steering stem.

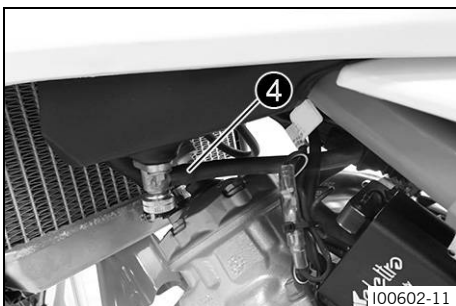

- Mount fuel hose **4**.
- Turn the knurled screw on the fuel tap all the way counter-clockwise.

Finishing work

- Mount the seat. (📖 p. 59)



12.16 Removing the start number plate

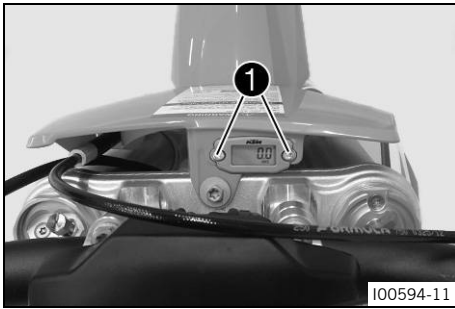

- Remove screws **1**.
- Hang the service hour counter to the side.

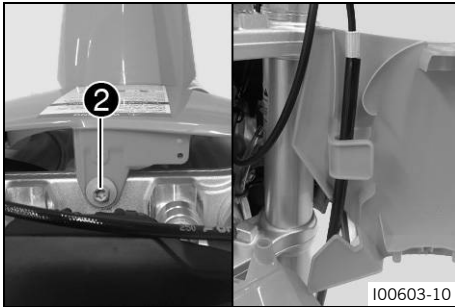

- Remove screw **2**.
- Unhook the start number plate from the brake line and remove it.

12.17 Installing the start number plate

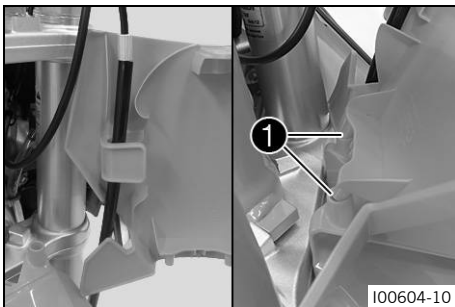

- Attach the start number plate to the brake line.
- Position the start number plate.
- ✓ Holding lugs **1** engage in the fender.

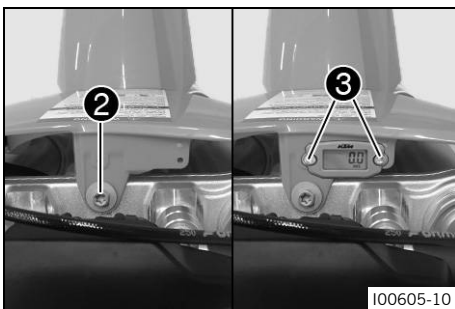

- Mount and tighten screw **2**.

Guideline

Screw, start number plate	M6	4 Nm (3 lbf ft)
---------------------------	----	-----------------

- Mount service hour counter and tighten with screws **3**.

Guideline

Remaining screws, chassis	M6	10 Nm (7.4 lbf ft)
---------------------------	----	--------------------

12.18 Removing front fender

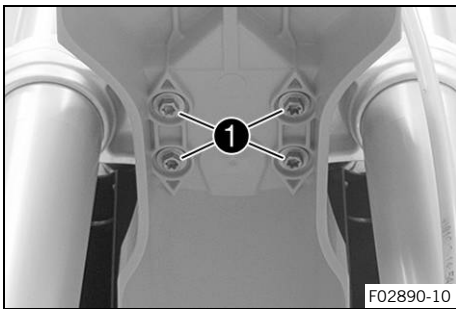

- Remove screws ①. Take off the front fender.



12.19 Installing front fender

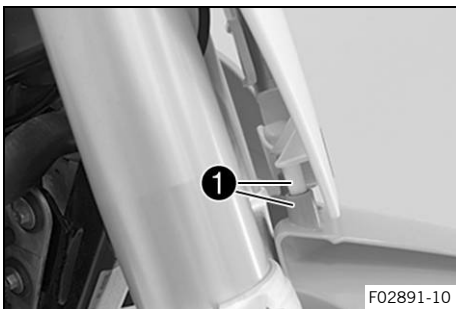

- Position the fender with drill holes ① in the holding lugs on the start number plate.

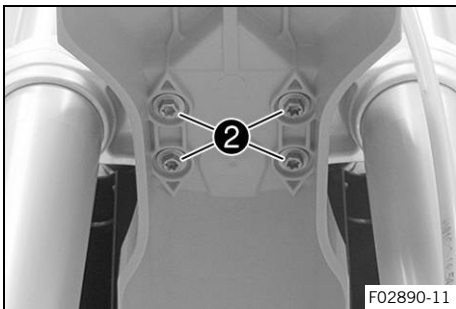

- Position front fender. Mount and tighten screws ②.

Guideline

Screw, fender	M6	6 Nm (4.4 lbf ft)
---------------	----	-------------------



12.20 Removing the left side cover

Preparatory work

- Remove the seat. (📖 p. 59)

Main work

- Remove left side cover from the rubber bushings in the areas A and B.
- Take off the left side cover.

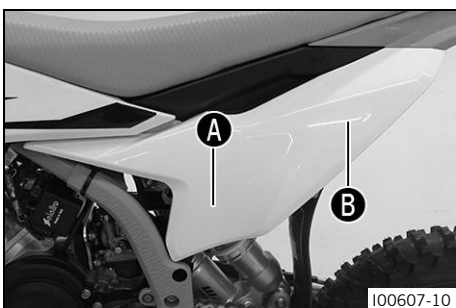

12.21 Installing the left side cover

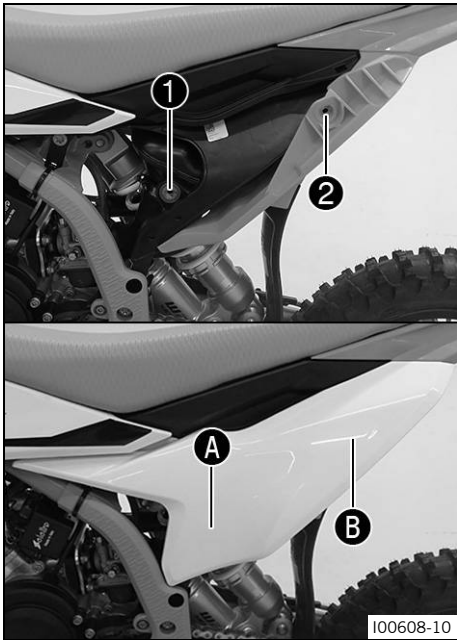

Main work

- Press the left side cover in area **A** into rubber bushing **1** and press into rubber bushing **B** in area **2**.

Finishing work

- Mount the seat. (📖 p. 59)

12.22 Removing the right side cover

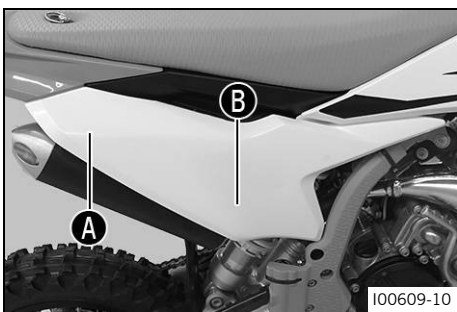

- Remove the side cover from the rubber bushings in areas **A** and **B**.
- Remove the right side cover.

12.23 Installing the right side cover

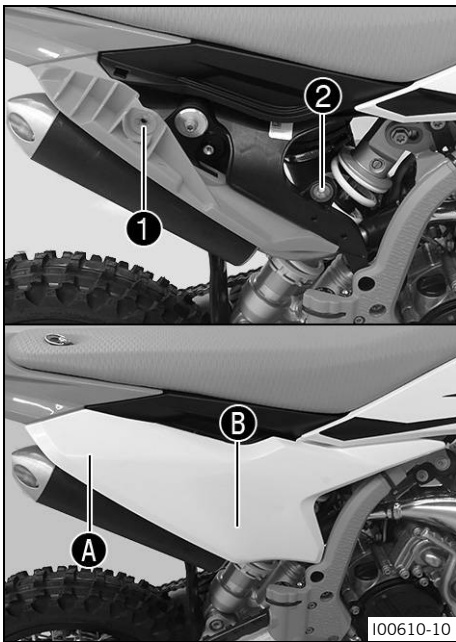

Main work

- Press the right side cover in the area **A** into rubber bushing **1** and press into rubber bushing **B** in area **2**.

Finishing work

- Mount the seat. (📖 p. 59)



12.24 Preparing the side cover for securing 🛠️

Preparatory work

- Remove the seat. (📖 p. 59)
- Remove the left side cover. (📖 p. 55)
- Remove the right side cover. (📖 p. 56)

Main work

- Drill a hole at the markings in area **A**.

Guideline

Diameter	5.5 mm (0.217 in)
----------	-------------------

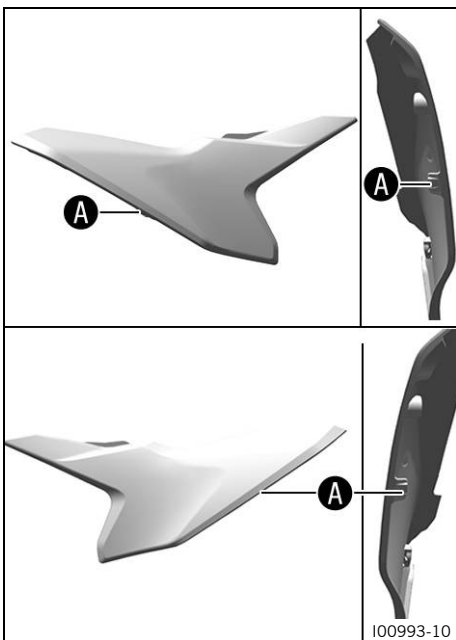

Finishing work

- Install the left side cover. (📖 p. 56)
- Install the right side cover. (📖 p. 57)
- Mount the seat. (📖 p. 59)

12.25 Removing the shock absorber 🛠️

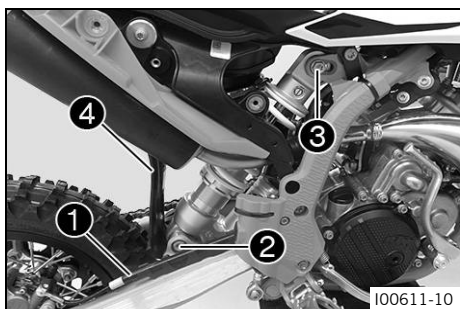

Preparatory work

- Raise the motorcycle with a lift stand. (📖 p. 43)

Main work

- Pull brake line **1** out of the holder.
- Remove screw **2** and lower the link fork carefully.
- Remove screw **3**, push splash protector **4** to the side, and remove the shock absorber.

12.26 Installing the shock absorber 🛠️



Warning

Danger of accidents Modifications to the suspension setting may seriously alter the handling characteristic.

- Ride slowly to start with after making adjustments to get the feel of the new handling characteristic.

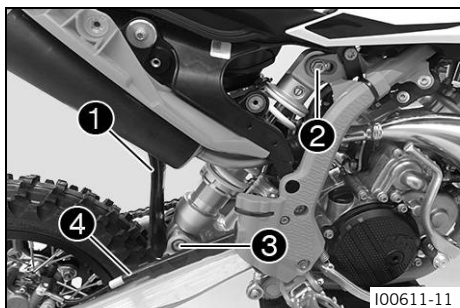

Main work

- Push splash protector **1** to the side.
- Position the shock absorber with screw **2**, depending on the desired seating height.
- Raise the link fork, mount and tighten the shock absorber with screw **3**.

Guideline

Screw, bottom shock absorber	M10	45 Nm (33.2 lbf ft) Loctite®243™
------------------------------	-----	--

- Tighten screw **2**.

Guideline

Screw, top shock absorber	M10	45 Nm (33.2 lbf ft) Loctite®243™
---------------------------	-----	--

- Attach brake line **4** to the holder.

Finishing work

- Remove the motorcycle from the lift stand. (📖 p. 43)

12.27 Removing the seat

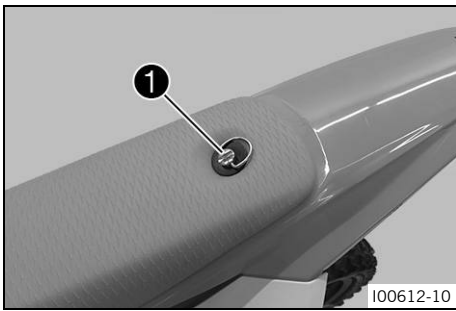

- Open quick release **1** and raise the rear of the seat.
- Pull back the seat and remove it.



12.28 Mounting the seat

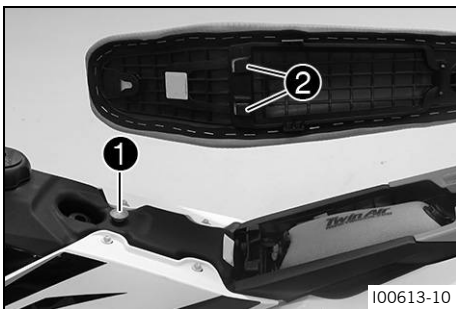

- Hook seat onto screw **1** and lower the seat at the rear and push it forward.
- ✓ Holding lug **2** hooks into the fuel tank.

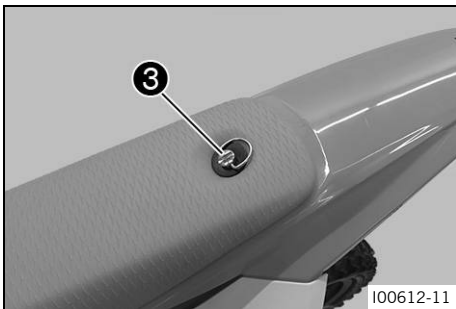

- Close quick release **3**.



12.29 Removing the frame protector

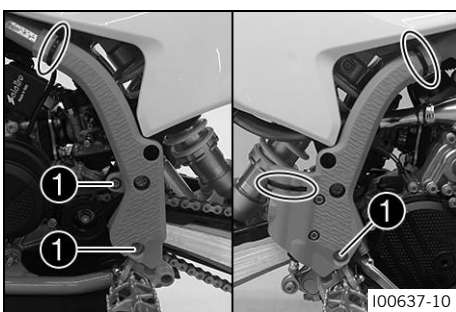

- Remove the cable ties.
- Remove screws **1** with the bushings.
- Take off the left frame protector.
- Push the right frame protector to the front and take off at the bottom.



12.30 Installing the frame protector

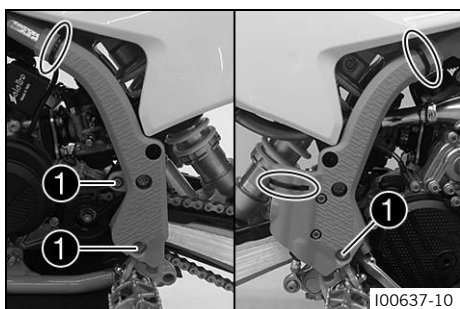

- Position the left frame protector.
- Insert the right frame protector from below and push it to the rear.
- Mount screws ① with the bushings and tighten.

Guideline

Remaining screws, chassis	M5	5 Nm (3.7 lbf ft)
---------------------------	----	-------------------

- Secure the frame protector with cable ties.

12.31 Removing the air filter

Note

Engine damage Unfiltered intake air has a negative effect on the service life of the engine.

Dust and dirt will enter the engine without an air filter.

- Only operate the vehicle if it is equipped with an air filter.



Note

Environmental hazard Hazardous substances cause environmental damage.

- Dispose of oils, grease, filters, fuel, cleaning agents, brake fluid, etc., correctly and in compliance with the applicable regulations.

Preparatory work

- Remove the seat. (📖 p. 59)

Main work

- Detach retaining tab ①. Remove the air filter to the front.



12.32 Installing the air filter



Main work

- Insert a clean air filter in area A.
- Secure air filter with retaining pin ①.



Info

If the air filter is not mounted correctly, dust and dirt may enter the engine and result in damage.

Finishing work

- Mount the seat. (📖 p. 59)

12.33 Cleaning the air filter and air filter box ↘



Note

Environmental hazard Hazardous substances cause environmental damage.

- Dispose of oils, grease, filters, fuel, cleaning agents, brake fluid, etc., correctly and in compliance with the applicable regulations.



Info

Do not clean the air filter with fuel or petroleum since these substances attack the foam.

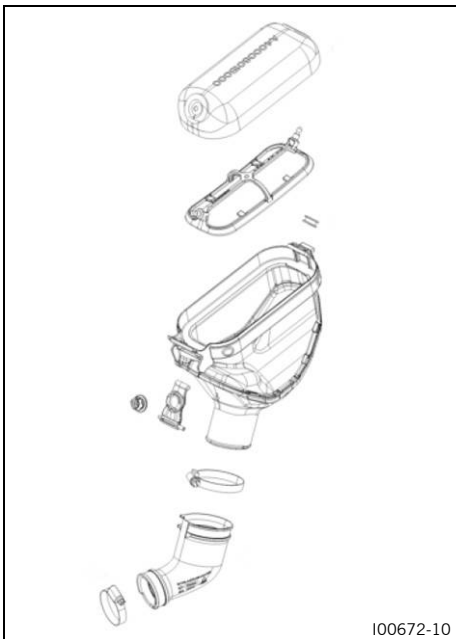

Preparatory work

- Remove the seat. (📖 p. 59)
- Remove the air filter. ↘ (📖 p. 60)

Main work

- Wash the air filter thoroughly in special cleaning liquid and allow it to dry properly.

Air filter cleaner (📖 p. 127)



Info

Only press the air filter to dry it, never wring it out.

- Oil the dry air filter with a high-grade air filter oil.

Oil for foam air filter (📖 p. 127)

- Clean the air filter box.
- Check intake flange for damage and looseness.

Finishing work

- Install the air filter. ↘ (📖 p. 60)
- Mount the seat. (📖 p. 59)



12.34 Removing the main silencer



Warning

Danger of burns The exhaust system gets hot when the vehicle is driven.

- Allow the exhaust system to cool down before performing any work on the vehicle.

Preparatory work

- Remove the right side cover. (📖 p. 56)

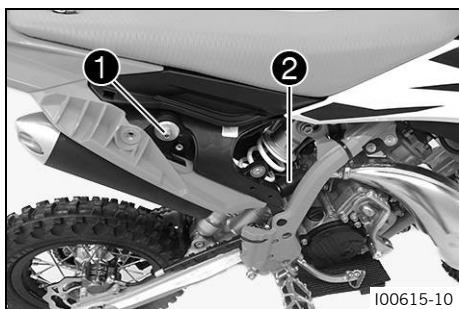

Main work

- Remove screw ①.
- Pull off the main silencer from the manifold at sleeve ②.

12.35 Installing the main silencer

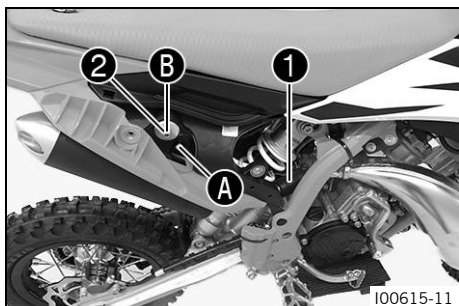

Main work

- Position the main silencer.
- Mount the main silencer with sleeve ①.

Guideline

High seat position	①
Low seat position	②

- Mount and tighten screw ②.

Guideline

Remaining screws, chassis	M6	10 Nm (7.4 lbf ft)
---------------------------	----	--------------------

Finishing work

- Install the right side cover. (📖 p. 57)
- Mount the seat. (📖 p. 59)

12.36 Changing the rock wool on the main silencer



Warning

Danger of burns The exhaust system gets hot when the vehicle is driven.

- Allow the exhaust system to cool down before performing any work on the vehicle.



Info

Over time, the rock wool fibers disappear, and the main silencer “burns out”. Not only is the noise level higher, but the performance characteristics change.

Preparatory work

- Remove the right side cover. (📖 p. 56)
- Remove main silencer. (📖 p. 61)

Main work

(50 SX)

- Remove screws with toothed washers ① from the silencer cap ②.
- Remove end cap and outer tube ③.
- Remove rock wool ④ from the inner tube.
- Clean the parts that need to be reinstalled and check for damage.
- Fit new rock wool on the inner tube.

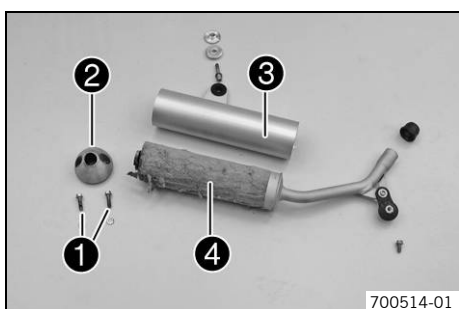

- Slide outer tube over the rock wool.
- Insert the silencer cap into the outer tube.
- Mount and tighten the screws with the toothed washers.

Guideline

Remaining screws, chassis	M6	10 Nm (7.4 lbf ft)
---------------------------	----	--------------------

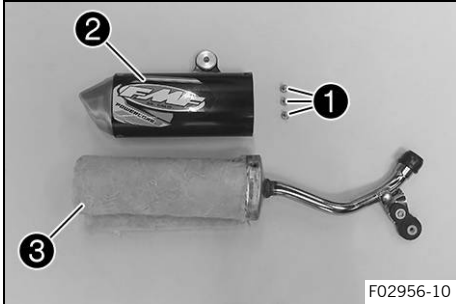

(FACTORY EDITION)

- Remove screws ① of the outer tube.
- Take off the outer tube and silencer cap ②.
- Remove rock wool ③ from the inner tube.
- Clean the parts that need to be reinstalled and check for damage.
- Fit new rock wool on the inner tube.
- Slide outer tube and silencer cap ② over the rock wool.
- Mount and tighten the screws.

Guideline

Screws on main silencer	M5	9 Nm (6.6 lbf ft) Loctite®243™
-------------------------	----	--

Finishing work

- Install the main silencer. (📖 p. 62)
- Install the right side cover. (📖 p. 57)
- Mount the seat. (📖 p. 59)

12.37 Removing the engine sprocket cover

Preparatory work

- Raise the motorcycle with a lift stand. (📖 p. 43)

Main work

- Remove screws ①.
- Remove screw ②.
- Take off the engine sprocket cover.

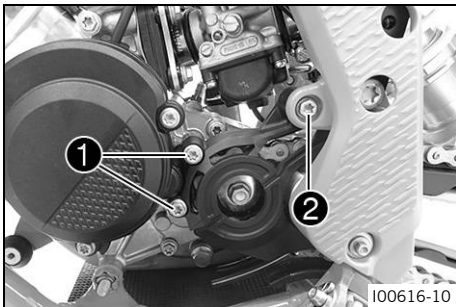

12.38 Installing the engine sprocket cover

Main work

- Position the engine sprocket cover. Mount screws ①, but do not tighten yet.
- Mount and tighten screw ②.

Guideline

Screw, engine sprocket cover	M6	8 Nm (5.9 lbf ft)
------------------------------	----	-------------------

- Tighten screws ①.

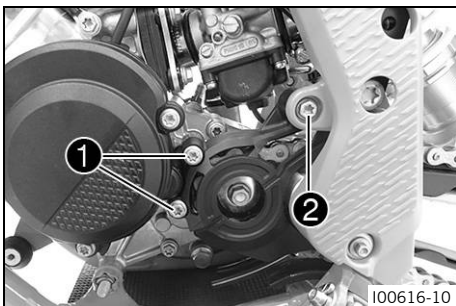

Guideline

Screw, engine sprocket cover	M6	8 Nm (5.9 lbf ft)
------------------------------	----	-------------------

Finishing work

- Remove the motorcycle from the lift stand. (📖 p. 43)

12.39 Checking the chain for dirt

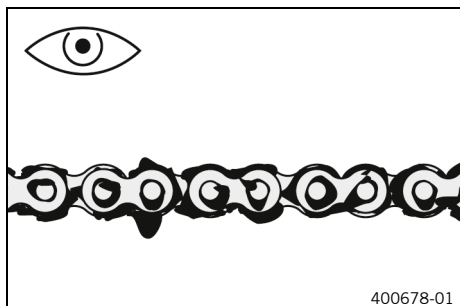

- Check the chain for coarse dirt accumulation.
 - » If the chain is very dirty:
 - Clean the chain. (📖 p. 64)

12.40 Cleaning the chain



Warning

Danger of accidents Lubricants on the tires reduces the road grip.

- Remove lubricants from the tires using a suitable cleaning agent.



Warning

Danger of accidents Oil or grease on the brake discs reduces the braking effect.

- Always keep the brake discs free of oil and grease.
- Clean the brake discs with brake cleaner when necessary.



Note

Environmental hazard Hazardous substances cause environmental damage.

- Dispose of oils, grease, filters, fuel, cleaning agents, brake fluid, etc., correctly and in compliance with the applicable regulations.



Info

The service life of the chain depends largely on its maintenance.

Preparatory work

- Raise the motorcycle with a lift stand. (📖 p. 43)

Main work

- Rinse off loose dirt with a soft jet of water.
- Remove old grease residue with chain cleaner.

Chain cleaner (📖 p. 127)

- After drying, apply chain spray.

Off-road chain spray (📖 p. 127)

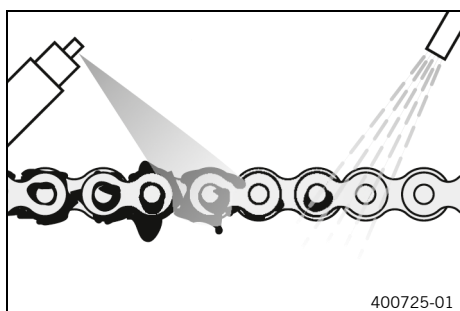

Finishing work

- Remove the motorcycle from the lift stand. (📖 p. 43)



12.41 Checking the chain tension



Warning

Danger of accidents Incorrect chain tension damages components and results in accidents.

If the chain is tensioned too much, the chain, engine sprocket, rear sprocket, transmission and rear wheel bearings wear more quickly. Some components may break if overloaded.

If the chain is too loose, the chain may fall off the engine sprocket or the rear sprocket. As a result, the rear wheel locks or the engine will be damaged.

- Check the chain tension regularly.
- Set the chain tension in accordance with the specification.

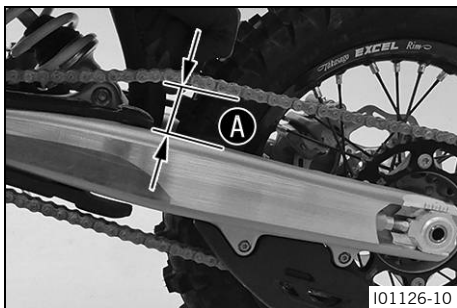

Preparatory work

- Raise the motorcycle with a lift stand. (📖 p. 43)

Main work

- Press the chain upward at the end of the chain sliding piece and determine chain tension **A**.



Info

Chain wear is not always even, so repeat this measurement at different positions on the chain.

Chain tension	35 ... 38 mm (1.38 ... 1.5 in)
---------------	--------------------------------

- » If the chain tension does not meet the specification:
 - Adjust the chain tension. (📖 p. 65)

Finishing work

- Remove the motorcycle from the lift stand. (📖 p. 43)



12.42 Adjusting the chain tension



Warning

Danger of accidents Incorrect chain tension damages components and results in accidents.

If the chain is tensioned too much, the chain, engine sprocket, rear sprocket, transmission and rear wheel bearings wear more quickly. Some components may break if overloaded.

If the chain is too loose, the chain may fall off the engine sprocket or the rear sprocket. As a result, the rear wheel locks or the engine will be damaged.

- Check the chain tension regularly.
- Set the chain tension in accordance with the specification.

Preparatory work

- Raise the motorcycle with a lift stand. (📖 p. 43)
- Check the chain tension. (📖 p. 65)

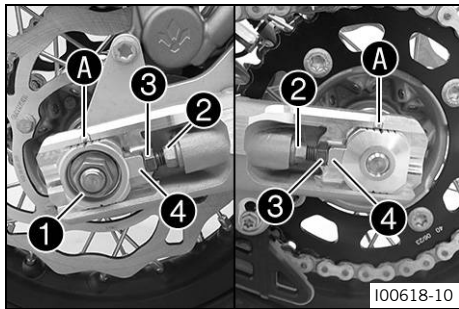

Main work

- Loosen nut ①.
- Loosen nuts ②.
- Adjust the chain tension by turning adjusting screws ③ left and right.

Guideline

Chain tension	35 ... 38 mm (1.38 ... 1.5 in)	
Turn adjusting screws ③ on the left and right so that the markings on left and right chain adjusters ④ are in the same position relative to reference marks A. The rear wheel is then correctly aligned.		

- Tighten nuts ②.
- Make sure that chain adjusters ④ are fitted correctly on adjusting screws ③.
- Tighten nut ①.

Guideline

Rear wheel spindle nut	M12x1	70 Nm (51.6 lbf ft)
------------------------	-------	---------------------

Finishing work

- Remove the motorcycle from the lift stand. (📖 p. 43)

12.43 Checking the chain, rear sprocket, engine sprocket, and chain guide

Preparatory work

- Raise the motorcycle with a lift stand. (📖 p. 43)
- Remove the engine sprocket cover. (📖 p. 63)

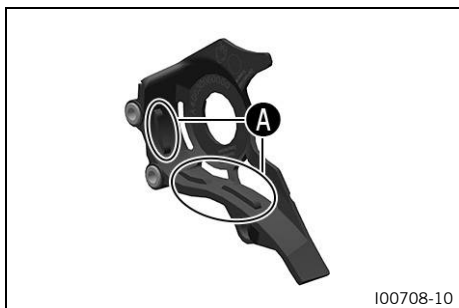

Main work

- Check the engine sprocket cover for wear.
 - » If the engine sprocket cover is worn through in the marked area A:
 - Change the engine sprocket cover. 🛠️
- Check the engine sprocket cover for tightness.
 - » If the engine sprocket cover is loose:
 - Tighten the engine sprocket cover.

Guideline

Screw, engine sprocket cover	M6	8 Nm (5.9 lbf ft)
------------------------------	----	-------------------

- Check the rear sprocket and the engine sprocket for wear.
 - » If the rear sprocket or engine sprocket is worn:
 - Change the drivetrain kit. 🛠️

Info

The engine sprocket, rear sprocket and chain should always be replaced together. When fitting the chain joint, always make sure that the closed side of the joint faces forward (direction of travel).

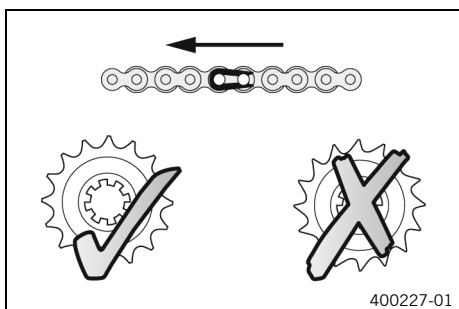

- Check the chain for wear.

- » If the chain is worn:
 - Change the drivetrain kit. 🛠️

i Info

When a new chain is mounted, the rear sprocket and the engine sprocket should also be changed.
New chains wear out faster on old, worn sprockets.

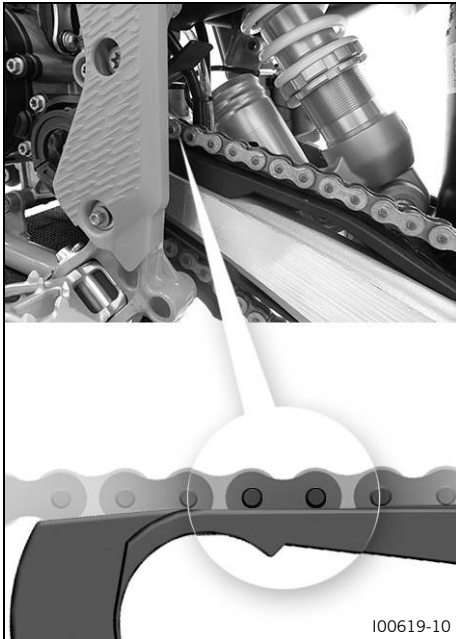

- Check the chain sliding guard for wear.
 - » If the ridge is worn down to the level of the main corpus:
 - Change the chain sliding guard. 🛠️
- Check that the chain sliding guard is firmly seated.
 - » If the chain sliding guard is loose:
 - Tighten the screw of the chain sliding guard.

Guideline

Remaining screws, chassis	M6	10 Nm (7.4 lbf ft)
---------------------------	----	-----------------------

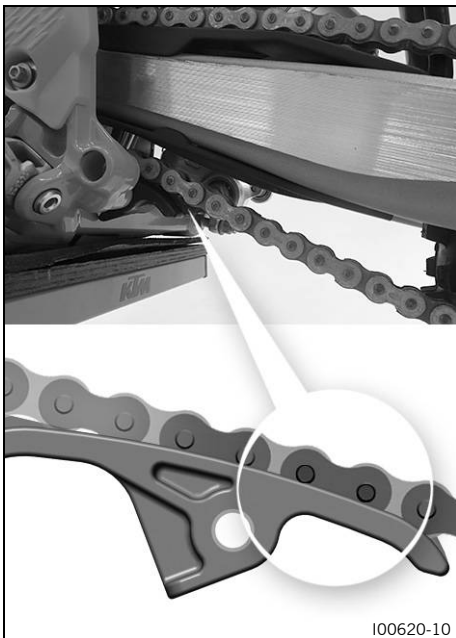

- Check the chain sliding piece for wear.
 - » If the lower edge of the chain pins is in line with or below the chain sliding piece:
 - Change the chain sliding piece. 🛠️
- Check that the chain sliding piece is firmly seated.
 - » If the chain sliding piece is loose:
 - Tighten the chain sliding piece.

Guideline

Screw, chain sliding piece	M8	15 Nm (11.1 lbf ft)
----------------------------	----	------------------------

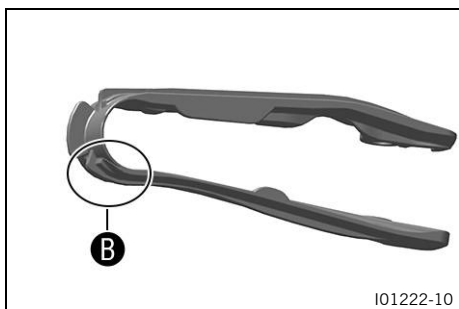

- Check the chain sliding piece for wear.
 - » If the chain sliding piece is worn through in the marked area **B**:
 - Change the chain sliding piece. 🛠️

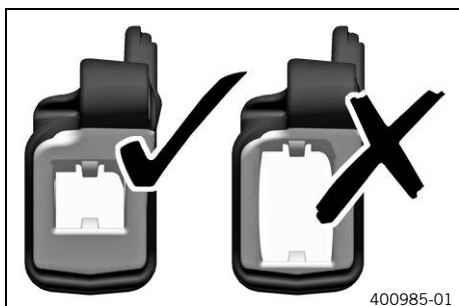

- Check the chain guide for wear.

i Info
Wear can be seen on the front of the chain guide.

- » If the light part of the chain guide is worn:
 - Change the chain guide. 🛠️



- Check that the chain guide is firmly seated.
 - » If the chain guide is loose:
 - Tighten the screws on the chain guide.

Guideline

Remaining screws, chassis	M6	10 Nm (7.4 lbf ft)
---------------------------	----	--------------------

Finishing work

- Install the engine sprocket cover. (📖 p. 63)
- Remove the motorcycle from the lift stand. (📖 p. 43)

12.44 Adjusting the chain guide 🛠️

i Info
The size of the chain wheel varies with the number of teeth. The chain guide can be adjusted on small sprockets.

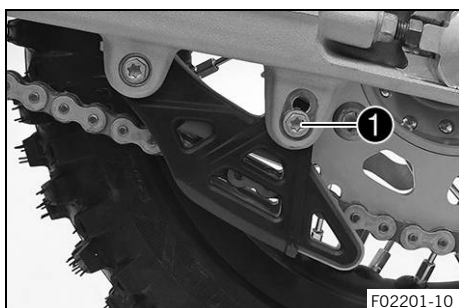

- Remove screw **1**.
- Position the chain guide.
- Mount and tighten screw **1**.

Guideline

Remaining screws, chassis	M6	10 Nm (7.4 lbf ft)
---------------------------	----	--------------------

12.45 Checking the frame ↩

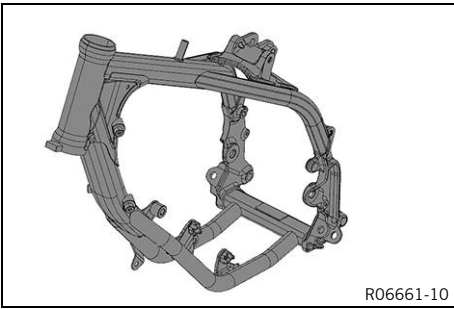

- Check the frame for damage, cracks, and deformation.
 - » If the frame shows signs of damage, cracks, or deformation:

- Change the frame. ↩

Guideline

Repairs on the frame are not permitted.

12.46 Checking the link fork ↩

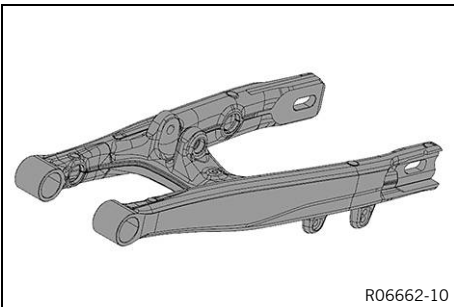

- Check the link fork for damage, cracks, and deformation.
 - » If the link fork shows signs of damage, cracks, or deformation:

- Change the link fork. ↩

Guideline

Repairs on the link fork are not permitted.

12.47 Checking the throttle cable routing



Warning

Danger of accidents The throttle cable can become kinked, trapped or blocked if it is not routed correctly.

If the throttle cable is kinked, trapped or blocked, the speed can no longer be controlled.

- Make sure that the throttle cable routing and the play in throttle cable complies with the specification.

Preparatory work

- Remove the seat. (📖 p. 59)
- Turn the knurled screw on the fuel tap all the way clockwise.
- Remove the fuel tank. ↩ (📖 p. 51)

Main work

- Check the throttle cable routing.

The throttle cable must be routed to the carburetor at the rear of the handlebar, above the fuel tank bracket. It must not be hooked into the handlebar cushion.

- » If the throttle cable routing is not as specified:
 - Correct the throttle cable routing.

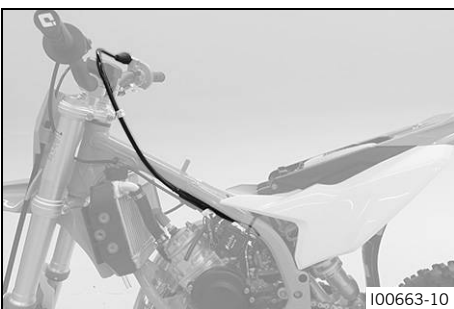

Finishing work

- Install the fuel tank. ↩ (📖 p. 52)
- Mount the seat. (📖 p. 59)

12.48 Checking the rubber grip

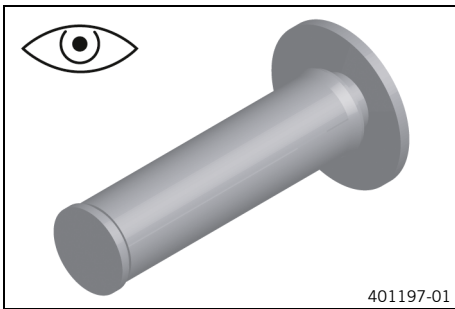

- Check the rubber grips on the handlebar for damage, wear, and looseness.



Info

The rubber grips are vulcanized onto a sleeve on the left and onto the handle tube of the throttle grip on the right. The left sleeve is clamped onto the handlebar. The rubber grip can only be replaced with the sleeve or the throttle tube.

- » If a rubber grip is damaged or worn:
 - Change the rubber grip.

- Check that screw **1** is firmly seated.

Guideline

Screw, fixed grip	M4	5 Nm (3.7 lbf ft) Loctite®243™
-------------------	----	--

Diamond **A** must be located at the top.

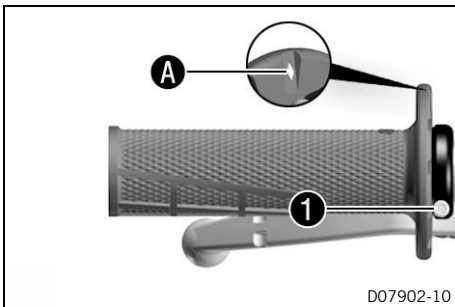

13.1 Checking play of handbrake lever



Warning

Danger of accidents The brake system fails in the event of overheating.

If there is no free travel on the hand brake lever, pressure builds up on the front brake circuit.

- Set the free travel on the hand brake lever in accordance with the specification.

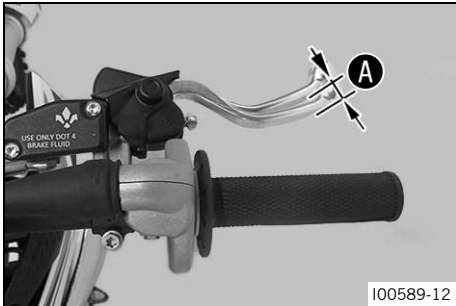

- Push the handbrake lever forwards and check play **A**.

Play of hand brake lever	3 ... 5 mm (0.12 ... 0.2 in)
--------------------------	------------------------------

» If the play does not meet specifications:

- Adjust the play of the hand brake lever.

13.2 Adjusting the basic position of the hand brake lever

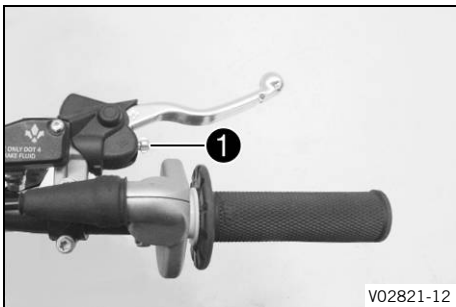

- Adjust the basic position of the hand brake lever using adjusting screw **1**.

i Info

Turn the adjusting screw clockwise to increase the distance between the hand brake lever and the handlebar.

Turn the adjusting screw counterclockwise to decrease the distance between the hand brake lever and the handlebar.

The range of adjustment is limited.

Turn the adjusting screw by hand only, and do not apply any force.

Do not make any adjustments while riding.

13.3 Checking the brake discs



Warning

Danger of accidents Worn-out brake discs reduce the braking effect.

- Make sure that worn-out brake discs are replaced immediately. (Your authorized KTM workshop will be glad to help.)

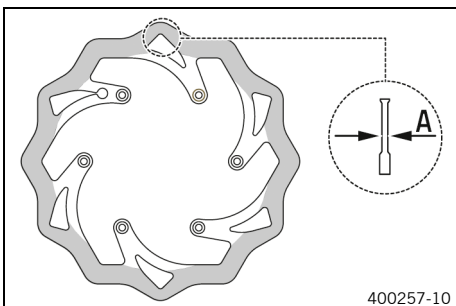

- Check the front and rear brake disc thickness at multiple points for the dimension **A**.

i Info

Wear reduces the thickness of the brake disc around the contact surface of the brake linings.

Brake discs - wear limits	
front	2.2 mm (0.087 in)

rear	2.2 mm (0.087 in)
------	-------------------

- » If the brake disc thickness is less than the specified value:
 - Change the front brake disc. 🛠️
 - Change the rear brake disc. 🛠️
- Check the front and rear brake discs for damage, cracking, and deformation.
 - » If the brake disc exhibits damage, cracking, or deformation:
 - Change the front brake disc. 🛠️
 - Change the rear brake disc. 🛠️

13.4 Checking the front brake fluid level



Warning

Danger of accidents An insufficient brake fluid level will cause the brake system to fail.

If the brake fluid level drops below the specified marking or the specified value, the brake system is leaking or the brake linings are worn down.

- Check the brake system and do not continue riding until the problem is eliminated. (Your authorized KTM workshop will be glad to help.)



Warning

Skin irritation Brake fluid is a harmful substance.

- Keep brake fluid out of the reach of children.
- Wear suitable protective clothing and safety glasses.
- Do not allow brake fluid to come into contact with the skin, the eyes or clothing.
- Consult a doctor immediately if brake fluid has been swallowed.
- Rinse the affected area with plenty of water in the event of contact with the skin.
- Rinse eyes thoroughly with water immediately and consult a doctor if brake fluid comes into contact with the eyes.
- If brake fluid spills on to your clothing, change the clothing.



Warning

Danger of accidents Brake fluid which is too old or of the wrong type impairs the function of the brake system.

- Make sure that brake fluid for the front and rear brake is changed in accordance with the service schedule. (Your authorized KTM workshop will be glad to help.)
- Make sure that only clean, approved brake fluid from a tightly sealed container is used. (Your authorized KTM workshop will be glad to help.)



Note

Environmental hazard Hazardous substances cause environmental damage.

- Dispose of oils, grease, filters, fuel, cleaning agents, brake fluid, etc., correctly and in compliance with the applicable regulations.



Info

Avoid contact between brake fluid and painted parts. Brake fluid corrodes paint.

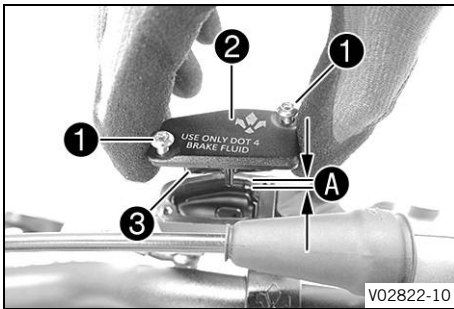

- Move the brake fluid reservoir mounted on the handlebar to a horizontal position.
- Remove screws ①.
- Take off cover ② with membrane ③.
- Check the brake fluid level.

Guideline

Level A (fluid level below container rim)	4 mm (0.16 in)
--	----------------

- » If the brake fluid level does not meet specifications:
 - Add front brake fluid. 📖 (p. 73)
- Position the cover with the membrane. Mount and tighten the screws.



Info

Use water to immediately clean up any brake fluid that has overflowed or spilled.



13.5 Adding front brake fluid 📖



Warning

Danger of accidents An insufficient brake fluid level will cause the brake system to fail.

If the brake fluid level drops below the specified marking or the specified value, the brake system is leaking or the brake linings are worn down.

- Check the brake system and do not continue riding until the problem is eliminated. (Your authorized KTM workshop will be glad to help.)



Warning

Skin irritation Brake fluid is a harmful substance.

- Keep brake fluid out of the reach of children.
- Wear suitable protective clothing and safety glasses.
- Do not allow brake fluid to come into contact with the skin, the eyes or clothing.
- Consult a doctor immediately if brake fluid has been swallowed.
- Rinse the affected area with plenty of water in the event of contact with the skin.
- Rinse eyes thoroughly with water immediately and consult a doctor if brake fluid comes into contact with the eyes.
- If brake fluid spills on to your clothing, change the clothing.



Warning

Danger of accidents Brake fluid which is too old or of the wrong type impairs the function of the brake system.

- Make sure that brake fluid for the front and rear brake is changed in accordance with the service schedule. (Your authorized KTM workshop will be glad to help.)
- Make sure that only clean, approved brake fluid from a tightly sealed container is used. (Your authorized KTM workshop will be glad to help.)



Note

Environmental hazard Hazardous substances cause environmental damage.

- Dispose of oils, grease, filters, fuel, cleaning agents, brake fluid, etc., correctly and in compliance with the applicable regulations.

i Info

Avoid contact between brake fluid and painted parts. Brake fluid corrodes paint.

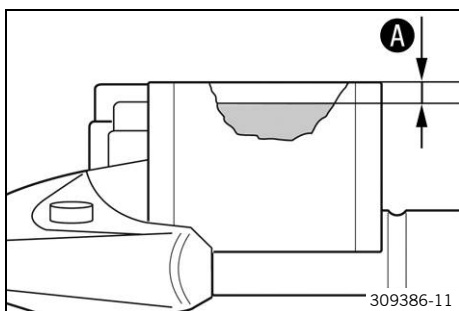
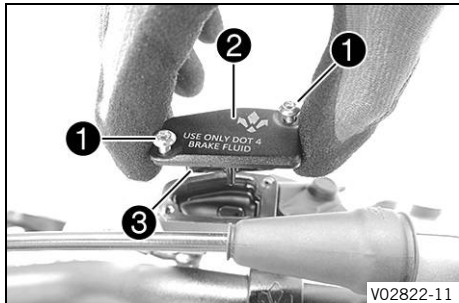

Preparatory work

- Check that the brake linings of the front brake are secured. (📖 p. 74)

Main work

- Move the brake fluid reservoir mounted on the handlebar to a horizontal position.
- Remove screws ①.
- Take off cover ② with membrane ③.

- Add brake fluid up to level A.

Guideline

Level A (brake fluid level below reservoir rim)	4 mm (0.16 in)
---	----------------

Brake fluid DOT 4 / DOT 5.1 (📖 p. 125)
--

- Position the cover with the membrane. Mount and tighten the screws.

i Info

Use water to immediately clean up any brake fluid that has overflowed or spilled.

13.6 Checking that the brake linings of the front brake are secured

Warning

Danger of accidents Worn-out brake linings reduce the braking effect.

- Ensure that worn-out brake linings are replaced immediately. (Your authorized KTM workshop will be glad to help.)

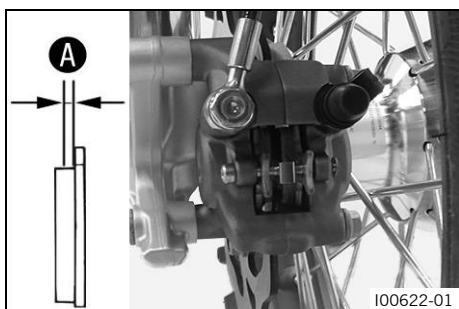

- Check the brake linings for lining thickness A.

Minimum thickness A	≥ 1 mm (≥ 0.04 in)
---------------------	--------------------

- » If it is less than the minimum thickness:
 - Change the brake linings of the front brake. (📖 p. 75)
- Check the brake linings for damage and cracking.
 - » If there is damage or cracking:
 - Change the brake linings of the front brake. (📖 p. 75)
- Check that the brake linings are secured.
 - » If the brake linings are not secured correctly:
 - Secure brake linings, replace with new parts if necessary.

13.7 Changing the front brake linings ↩



Warning

Danger of accidents Incorrect servicing will cause the brake system to fail.

- Ensure that service work and repairs are performed professionally. (Your authorized KTM workshop will be glad to help.)



Warning

Skin irritation Brake fluid is a harmful substance.

- Keep brake fluid out of the reach of children.
- Wear suitable protective clothing and safety glasses.
- Do not allow brake fluid to come into contact with the skin, the eyes or clothing.
- Consult a doctor immediately if brake fluid has been swallowed.
- Rinse the affected area with plenty of water in the event of contact with the skin.
- Rinse eyes thoroughly with water immediately and consult a doctor if brake fluid comes into contact with the eyes.
- If brake fluid spills on to your clothing, change the clothing.



Warning

Danger of accidents Brake fluid which is too old or of the wrong type impairs the function of the brake system.

- Make sure that brake fluid for the front and rear brake is changed in accordance with the service schedule. (Your authorized KTM workshop will be glad to help.)
- Make sure that only clean, approved brake fluid from a tightly sealed container is used. (Your authorized KTM workshop will be glad to help.)



Warning

Danger of accidents Brake linings which have not been approved alter the braking efficiency.

Not all brake linings are tested and approved for KTM motorcycles. The structure and friction coefficient of the brake linings, and thus their brake power, may vary greatly from that of original brake linings.

If brake linings are used that differ from the original equipment, compliance with the original homologation is not guaranteed. In this case, the vehicle no longer corresponds to its condition at delivery and the manufacturer warranty shall be void.

- Only use brake linings approved and recommended by KTM.



Note

Environmental hazard Hazardous substances cause environmental damage.

- Dispose of oils, grease, filters, fuel, cleaning agents, brake fluid, etc., correctly and in compliance with the applicable regulations.



Info

Avoid contact between brake fluid and painted parts. Brake fluid corrodes paint.

Preparatory work

- Raise the motorcycle with a lift stand. (📖 p. 43)

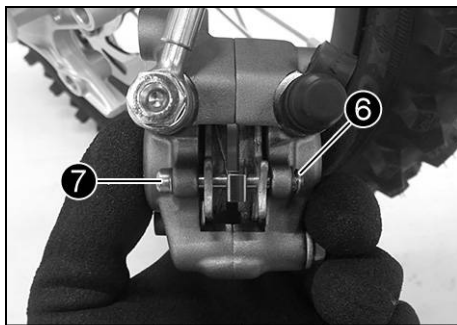
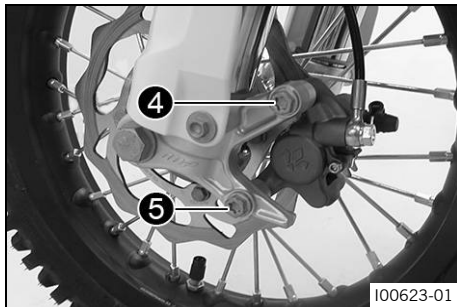
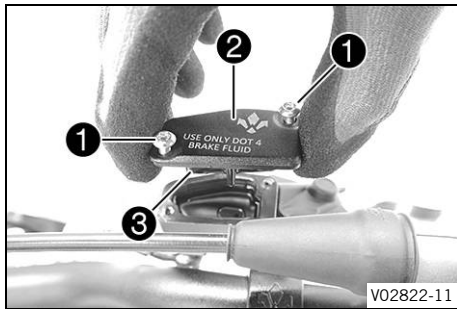

Main work

- Move the brake fluid reservoir mounted on the handlebar to a horizontal position.
- Remove screws ①.
- Take off cover ② with membrane ③.
- Remove screw ④ and screw ⑤.
- Press back the brake linings by slightly tilting the brake caliper laterally on the brake disc. Carefully pull the brake caliper backward from the brake disc.
- Press the brake piston back into the basic position and ensure that brake fluid does not flow out of the brake fluid reservoir; extract some if necessary.
- Remove lock ring ⑥.
- Remove screw ⑦.
- Remove the brake linings.
- Clean the brake caliper and the brake caliper bracket.



Warning

Danger of accidents Brake linings which have not been approved alter the braking efficiency.

Not all brake linings are tested and approved for KTM motorcycles. The structure and friction coefficient of the brake linings, and thus their brake power, may vary greatly from that of original brake linings.

If brake linings are used that differ from the original equipment, compliance with the original homologation is not guaranteed. In this case, the vehicle no longer corresponds to its condition at delivery and the manufacturer warranty shall be void.

- Only use brake linings approved and recommended by KTM.

- Position the new brake linings.



Info

Always change the brake linings in pairs. Ensure that the brake linings are correctly positioned in the holding spring.

- Mount and tighten screw ⑦.

Guideline

Screw, brake linings	M5	5 Nm (3.7 lbf ft)
----------------------	----	-------------------

- Mount lock ring ⑥.



Warning

Danger of accidents Oil or grease on the brake discs reduces the braking effect.

- Always keep the brake discs free of oil and grease.
- Clean the brake discs with brake cleaner when necessary.

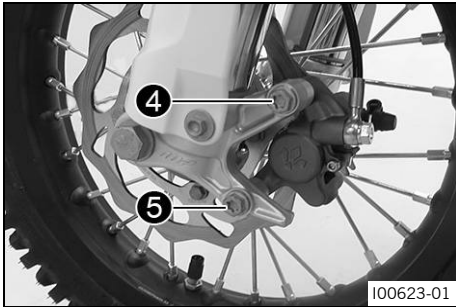

- Check the brake discs. (📖 p. 71)
- Position the brake caliper.
- Mount screw **4**, but do not tighten it yet.

Guideline

Screw, front brake caliper	M8x35	20 Nm (14.8 lbf ft) Loctite®243™
----------------------------	-------	--

- Mount screw **5**, but do not tighten it yet.

Guideline

Screw, front brake caliper	M8x35	20 Nm (14.8 lbf ft) Loctite®243™
----------------------------	-------	--

- Operate the hand brake lever repeatedly until the brake linings are in contact with the brake disc and there is a pressure point. Secure the hand brake lever in the activated position.

✓ The brake caliper straightens.

- Tighten screw **4**.

Guideline

Screw, front brake caliper	M8x35	20 Nm (14.8 lbf ft) Loctite®243™
----------------------------	-------	--

- Tighten screw **5**.

Guideline

Screw, front brake caliper	M8x35	20 Nm (14.8 lbf ft) Loctite®243™
----------------------------	-------	--

- Remove the locking piece of the hand brake lever.

- Correct the brake fluid level.

Guideline

Brake fluid level below reservoir rim	5 mm (0.2 in)
---------------------------------------	---------------

Brake fluid DOT 4 / DOT 5.1 (📖 p. 125)

- Position cover **2** with membrane **3**.
- Mount and tighten screws **1**.

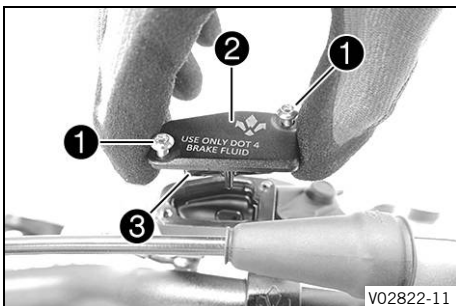

Info

Use water to immediately clean up any brake fluid that has overflowed or spilled.

Finishing work

- Remove the motorcycle from the lift stand. (📖 p. 43)

13.8 Checking the free travel of the foot brake lever



Warning

Danger of accidents The brake system will fail if it overheats or is adjusted incorrectly.

If there is no free travel on the foot brake lever, pressure builds up in the brake system on the rear brake.

- Set the free travel on the foot brake lever in accordance with the specification.
- Ensure that the adjustment steps are performed properly. (Your authorized KTM workshop will be glad to help.)

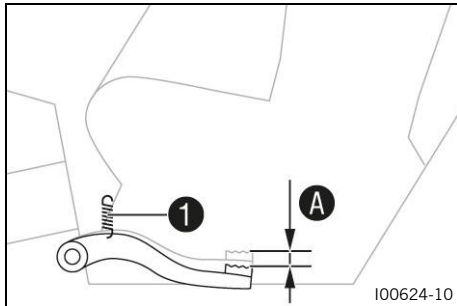

- Detach spring **1**.
- Move the foot brake lever back and forth between the end stop and the contact to the foot brake cylinder piston and check free travel **A**.

Guideline

Free travel of foot brake lever	3 ... 5 mm (0.12 ... 0.2 in)
---------------------------------	------------------------------

» If the free travel does not match the specification:

- Adjust the free travel of the hand brake lever. (📖 p. 78)
- Attach spring **1**.

13.9 Adjusting the free travel of the foot brake lever



Warning

Danger of accidents The brake system will fail if it overheats or is adjusted incorrectly.

If there is no free travel on the foot brake lever, pressure builds up in the brake system on the rear brake.

- Set the free travel on the foot brake lever in accordance with the specification.
- Ensure that the adjustment steps are performed properly. (Your authorized KTM workshop will be glad to help.)

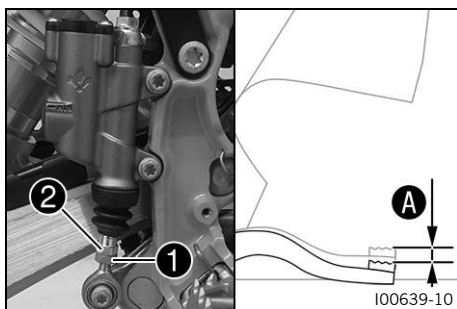

- Detach the foot brake lever spring.
- Loosen nut **1**.
- Turn push rod **2** accordingly until you have free travel **A**.

Guideline

Free travel of foot brake lever	3 ... 5 mm (0.12 ... 0.2 in)
---------------------------------	------------------------------

- Hold push rod **2** and tighten nut **1**.

Guideline

Nut, push rod, foot brake lever	M6	6 Nm (4.4 lbf ft)
---------------------------------	----	-------------------

- Attach the foot brake lever spring.
- Check whether the basic position of the foot brake lever is suitable for the rider.
 - » When the basic position of the foot brake lever needs to be adjusted:
 - Adjust the basic position of the foot brake lever. (📖 p. 79)

13.10 Adjusting the basic position of the foot brake lever ↩



Warning

Danger of accidents The brake system will fail if it overheats or is adjusted incorrectly.

If there is no free travel on the foot brake lever, pressure builds up in the brake system on the rear brake.

- Set the free travel on the foot brake lever in accordance with the specification.
- Ensure that the adjustment steps are performed properly. (Your authorized KTM workshop will be glad to help.)

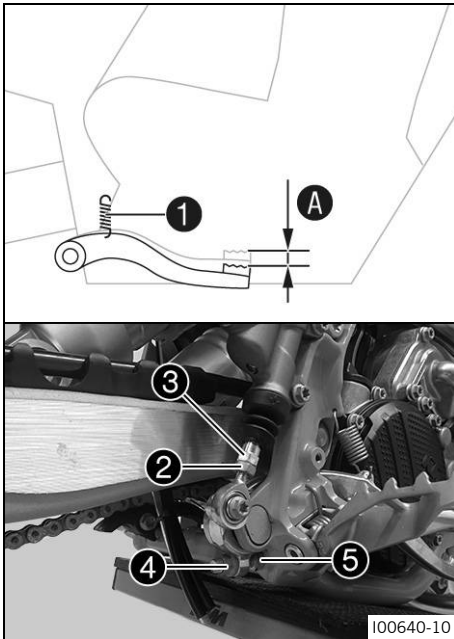

- Detach spring ①.
- Loosen nut ② and, with push rod ③, turn it back until you have maximum free travel.
- To adjust the basic position of the foot brake lever to individual requirements, loosen nut ④ and turn screw ⑤ accordingly.



Info

The range of adjustment is limited.

- Turn push rod ③ accordingly until you have free travel A. If necessary, adjust the basic position of the foot brake lever.

Guideline

Free travel of foot brake lever	3 ... 5 mm (0.12 ... 0.2 in)
---------------------------------	------------------------------

- Hold screw ⑤ and tighten nut ④.

Guideline

Remaining nuts, chassis	M6	10 Nm (7.4 lbf ft)
-------------------------	----	--------------------

- Hold push rod ③ and tighten nut ②.

Guideline

Remaining nuts, chassis	M6	10 Nm (7.4 lbf ft)
-------------------------	----	--------------------

- Attach spring ①.



13.11 Checking the rear brake fluid level



Warning

Danger of accidents An insufficient brake fluid level will cause the brake system to fail.

If the brake fluid level drops below the specified marking or the specified value, the brake system is leaking or the brake linings are worn down.

- Check the brake system and ensure that nobody drives the vehicle before the problem is eliminated. (Your authorized KTM workshop will be glad to help.)



Warning

Danger of accidents Brake fluid which is too old or of the wrong type impairs the function of the brake system.

- Make sure that brake fluid for the front and rear brake is changed in accordance with the service schedule. (Your authorized KTM workshop will be glad to help.)
- Make sure that only clean, approved brake fluid from a tightly sealed container is used. (Your authorized KTM workshop will be glad to help.)

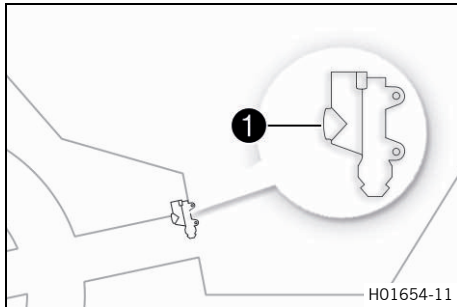

- Stand the vehicle upright.
- Check the brake fluid level in level viewer **1**.
 - » If an air bubble is visible in viewer **1**:
 - Add rear brake fluid. 🛠️ (📖 p. 80)

13.12 Adding rear brake fluid 🛠️



Warning

Danger of accidents An insufficient brake fluid level will cause the brake system to fail.

If the brake fluid level drops below the specified marking or the specified value, the brake system is leaking or the brake linings are worn down.

- Check the brake system and ensure that nobody drives the vehicle before the problem is eliminated. (Your authorized KTM workshop will be glad to help.)



Warning

Skin irritation Brake fluid is a harmful substance.

- Keep brake fluid out of the reach of children.
- Wear suitable protective clothing and safety glasses.
- Do not allow brake fluid to come into contact with the skin, the eyes or clothing.
- Consult a doctor immediately if brake fluid has been swallowed.
- Rinse the affected area with plenty of water in the event of contact with the skin.
- Rinse eyes thoroughly with water immediately and consult a doctor if brake fluid comes into contact with the eyes.
- If brake fluid spills on to your clothing, change the clothing.



Warning

Danger of accidents Brake fluid which is too old or of the wrong type impairs the function of the brake system.

- Make sure that brake fluid for the front and rear brake is changed in accordance with the service schedule. (Your authorized KTM workshop will be glad to help.)
- Make sure that only clean, approved brake fluid from a tightly sealed container is used. (Your authorized KTM workshop will be glad to help.)



Note

Environmental hazard Hazardous substances cause environmental damage.

- Dispose of oils, grease, filters, fuel, cleaning agents, brake fluid, etc., correctly and in compliance with the applicable regulations.

i Info

Avoid contact between brake fluid and painted parts. Brake fluid corrodes paint.

Preparatory work

- Raise the motorcycle with a lift stand. (📖 p. 43)
- Check that the brake linings of the rear brake are secured. (📖 p. 81)

Main work

- Remove screws ①.
- Take off cover ② with membrane ③.

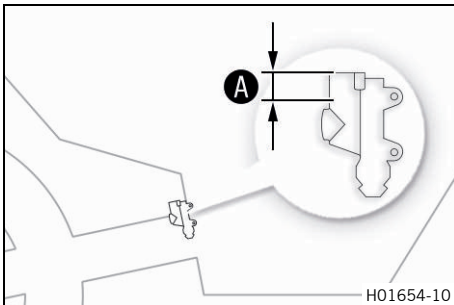
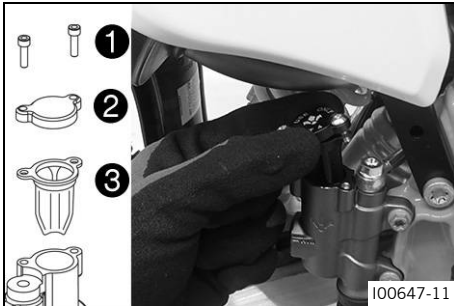

- Add brake fluid up to level A.

Guideline

Level A (brake fluid level below reservoir rim)	10 mm (0.39 in)
---	-----------------

Brake fluid DOT 4 / DOT 5.1 (📖 p. 125)
--

- Position cover with washer and membrane.
- Mount and tighten the screws.

i Info

Use water to immediately clean up any brake fluid that has overflowed or spilled.

Finishing work

- Remove the motorcycle from the lift stand. (📖 p. 43)

13.13 Checking that the brake linings of the rear brake are secured

Warning

Danger of accidents Worn-out brake linings reduce the braking effect.

- Ensure that worn-out brake linings are replaced immediately. (Your authorized KTM workshop will be glad to help.)

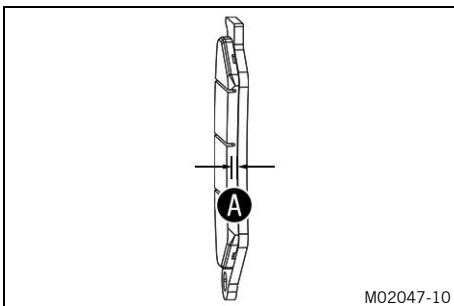

- Check the brake linings for minimum thickness A.

Minimum thickness A	≥ 1 mm (≥ 0.04 in)
---------------------	--------------------

- » If the minimum thickness is less than specified:
 - Change the rear brake linings. (📖 p. 82)
- Check the brake linings for damage and cracking.
 - » If damage or wear is encountered:
 - Change the rear brake linings. (📖 p. 82)
- Check that the brake linings are secured.
 - » If the brake linings are not secured correctly:

- Secure brake linings, replace with new parts if necessary.

13.14 Changing the rear brake linings



Warning

Danger of accidents Incorrect servicing will cause the brake system to fail.

- Ensure that service work and repairs are performed professionally. (Your authorized KTM workshop will be glad to help.)



Warning

Skin irritation Brake fluid is a harmful substance.

- Keep brake fluid out of the reach of children.
- Wear suitable protective clothing and safety glasses.
- Do not allow brake fluid to come into contact with the skin, the eyes or clothing.
- Consult a doctor immediately if brake fluid has been swallowed.
- Rinse the affected area with plenty of water in the event of contact with the skin.
- Rinse eyes thoroughly with water immediately and consult a doctor if brake fluid comes into contact with the eyes.
- If brake fluid spills on to your clothing, change the clothing.



Warning

Danger of accidents Brake fluid which is too old or of the wrong type impairs the function of the brake system.

- Make sure that brake fluid for the front and rear brake is changed in accordance with the service schedule. (Your authorized KTM workshop will be glad to help.)
- Make sure that only clean, approved brake fluid from a tightly sealed container is used. (Your authorized KTM workshop will be glad to help.)



Warning

Danger of accidents Oil or grease on the brake discs reduces the braking effect.

- Always keep the brake discs free of oil and grease.
- Clean the brake discs with brake cleaner when necessary.



Warning

Danger of accidents Brake linings which have not been approved alter the braking efficiency.

Not all brake linings are tested and approved for KTM motorcycles. The structure and friction coefficient of the brake linings, and thus their brake power, may vary greatly from that of original brake linings.

If brake linings are used that differ from the original equipment, compliance with the original homologation is not guaranteed. In this case, the vehicle no longer corresponds to its condition at delivery and the manufacturer warranty shall be void.

- Only use brake linings approved and recommended by KTM.



Note

Environmental hazard Hazardous substances cause environmental damage.

- Dispose of oils, grease, filters, fuel, cleaning agents, brake fluid, etc., correctly and in compliance with the applicable regulations.



Info

Avoid contact between brake fluid and painted parts. Brake fluid corrodes paint.

Preparatory work

- Raise the motorcycle with a lift stand. (📖 p. 43)

Main work

- Remove lock ring ①.
- Remove screw ②.
- Remove screw ③ and screw ④.

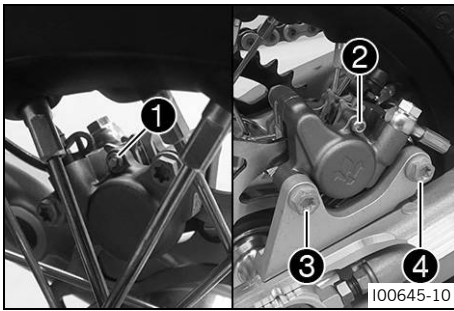

I00645-10

- Take off the brake caliper.



Info

Do not kink or damage the brake line.

- Remove the brake linings.
- Clean the brake caliper and the brake caliper bracket.
- Allow the brake caliper and the brake line to hang loosely to the side.
- Check the brake discs. (📖 p. 71)

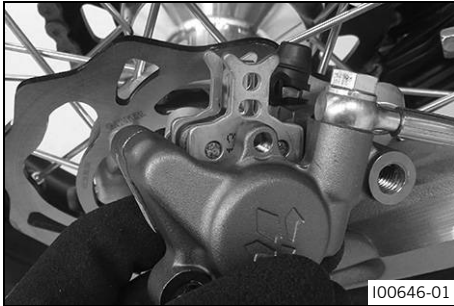

I00646-01

- Remove screws ⑤.
- Take off cover ⑥ with membrane ⑦.
- Press the brake piston back into the basic position and ensure that brake fluid does not flow out of the brake fluid reservoir; extract some if necessary.

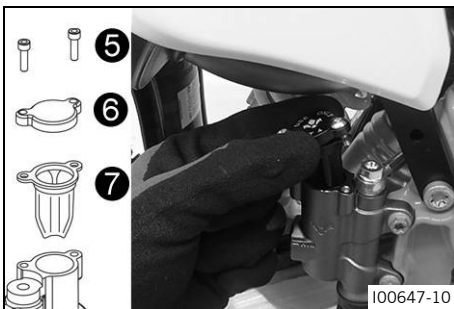

I00647-10

- Position the new brake linings.



Info

Always change the brake linings in pairs.
Ensure that the brake linings are correctly positioned in the holding spring.

- Position the brake caliper on the brake disc.
✓ The brake linings are correctly positioned.

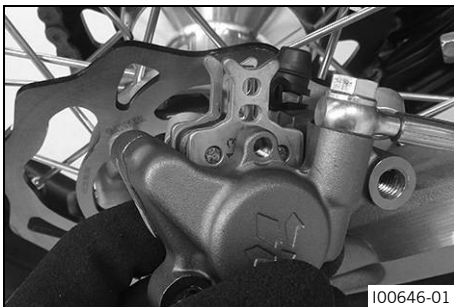

I00646-01

- Mount and tighten screw ③.

Guideline

Rear brake caliper screw	M8	20 Nm (14.8 lbf ft) Loctite®243™
--------------------------	----	--

- Mount and tighten screw ④.

Guideline

Rear brake caliper screw	M8	20 Nm (14.8 lbf ft) Loctite®243™
--------------------------	----	--

- Mount screw ②.

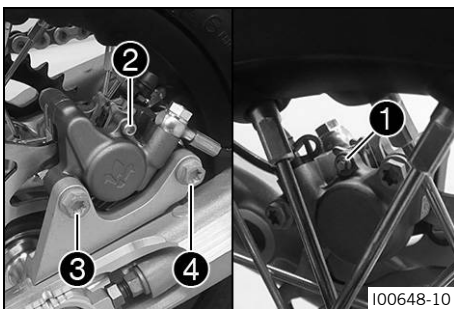

I00648-10

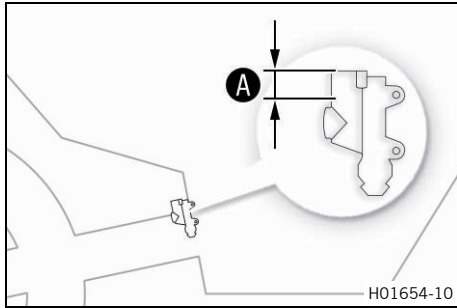

Guideline

Screw, brake linings	M5	5 Nm (3.7 lbf ft)
----------------------	----	-------------------

- Mount lock ring ❶.
- Operate the foot brake lever repeatedly until the brake linings are in contact with the brake disc and there is a pressure point.
- Add brake fluid up to level ❶.

Guideline

Level ❶ (brake fluid level below reservoir rim)	10 mm (0.39 in)
---	-----------------

Brake fluid DOT 4 / DOT 5.1 (📖 p. 125)
--

- Position cover with washer and membrane.
- Mount and tighten the screws.



Info

Use water to immediately clean up any brake fluid that has overflowed or spilled.

Finishing work

- Remove the motorcycle from the lift stand. (📖 p. 43)

14.1 Removing the front wheel ↩

Preparatory work

- Raise the motorcycle with a lift stand. (📖 p. 43)

Main work

- Remove screw ①.
- Loosen screws ②.

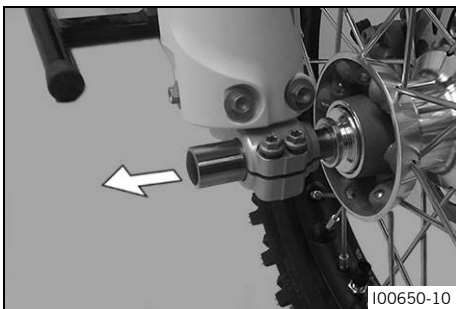
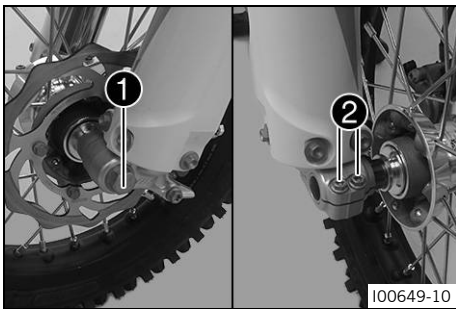

Warning

Danger of accidents Damaged brake discs reduce the braking effect.

- Always lay the wheel down in such a way that the brake disc is not damaged.

- Hold the front wheel and remove the wheel spindle. Take the front wheel out of the fork.



Info

Do not actuate the hand brake lever when the front wheel is removed.

- Remove spacers ③.

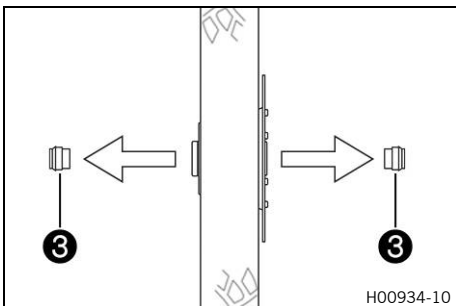

14.2 Installing the front wheel ↩



Warning

Danger of accidents Oil or grease on the brake discs reduces the braking effect.

- Always keep the brake discs free of oil and grease.
- Clean the brake discs with brake cleaner when necessary.

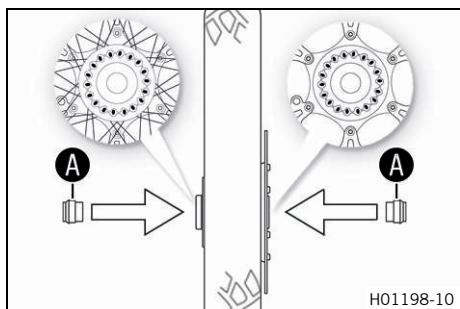

- Check the wheel bearing for damage and wear.
 - » If the wheel bearing is damaged or worn:
 - Change front wheel bearing. 🛠️
- Clean and grease the contact surfaces **A** of the spacers.

Long-life grease (📖 p. 127)

- Insert the spacers.

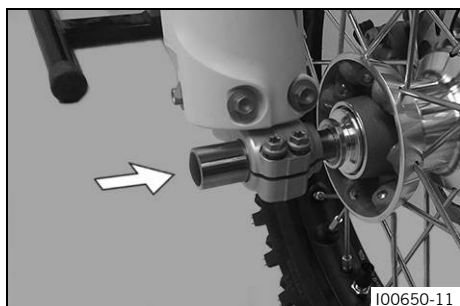

- Clean and grease the wheel spindle.

Long-life grease (📖 p. 127)

- Position the front wheel.
 - ✓ The brake linings are correctly positioned.
- Insert the wheel spindle.

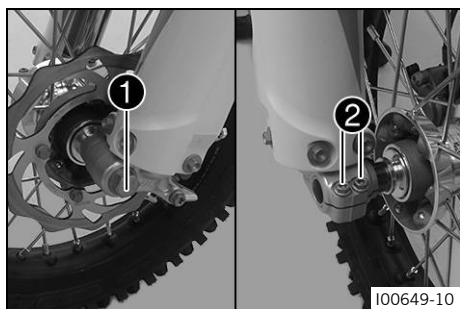

- Mount and tighten screw **1**.

Guideline

Screw, front wheel spindle	M10	40 Nm (29.5 lbf ft) Loctite®243™
----------------------------	-----	--

- Operate the hand brake lever several times until the brake linings are seated correctly against the brake disc.
- Remove the motorcycle from the lift stand. (📖 p. 43)
- Operate the front brake and compress the fork a few times firmly.
 - ✓ The fork legs straighten.
- Tighten screws **2**.

Guideline

Screw, fork stub	M6	10 Nm (7.4 lbf ft)
------------------	----	--------------------

14.3 Removing the rear wheel 🛠️

Preparatory work

- Raise the motorcycle with a lift stand. (📖 p. 43)

Main work

- Remove nut **1**.
- Take off chain adjuster **2**.

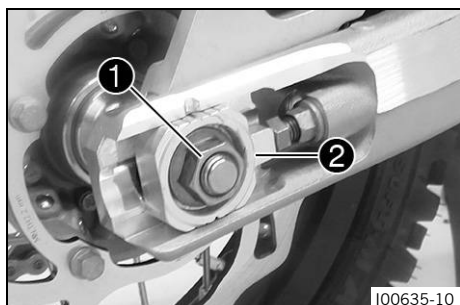

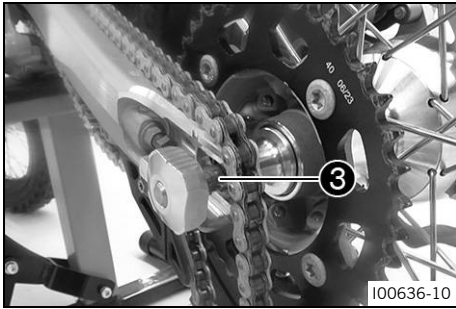

- Pull out wheel spindle **3** far enough to allow the rear wheel to be pushed forward.
- Push the rear wheel forward as far as possible. Remove the chain from the rear sprocket.

i Info
Cover the components to protect them against damage.

! Warning
Danger of accidents Damaged brake discs reduce the braking effect.

- Always lay the wheel down in such a way that the brake disc is not damaged.

- Hold the rear wheel and remove the wheel spindle. Take the rear wheel out of the link fork.

i Info
Do not operate the foot brake lever when the rear wheel is removed.

- Remove spacers **4**.

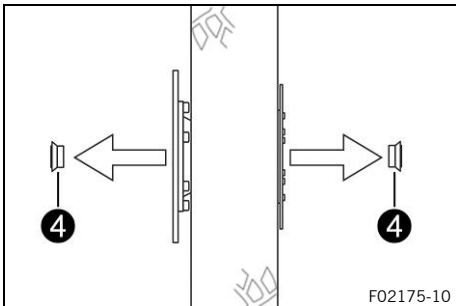

14.4 Installing the rear wheel

! Warning
Danger of accidents Oil or grease on the brake discs reduces the braking effect.

- Always keep the brake discs free of oil and grease.
- Clean the brake discs with brake cleaner when necessary.

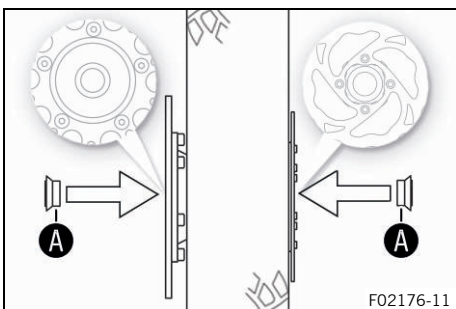

Main work

- Check the wheel bearing for damage and wear.
 - » If the wheel bearing is damaged or worn:
 - Change the rear wheel bearing.
- Clean and grease the contact surfaces **A** of the spacers.

Long-life grease (p. 127)

- Insert the spacers.

i Info
Insert the wide spacer on the left in the direction of travel.

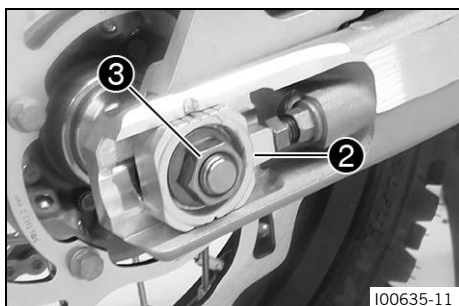
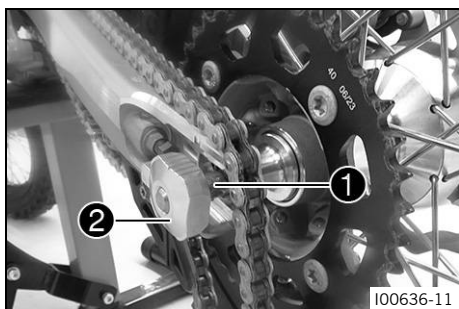

- Clean and grease wheel spindle ①.

Long-life grease (📖 p. 127)

- Position the rear wheel and insert wheel spindle.
 - ✓ The brake linings are correctly positioned.
- Mount the chain.
- Position chain adjuster ② on both sides and push the wheel spindle in all the way.

- Mount nut ③, but do not tighten yet.
- Make sure that the chain adjusters are fitted correctly on the adjusting screws.
- Check the chain tension. (📖 p. 65)
- Tighten nut ③.

Guideline

Rear wheel spindle nut	M12x1	70 Nm (51.6 lbf ft)
------------------------	-------	---------------------

- Operate the foot brake lever repeatedly until the brake linings are in contact with the brake disc and there is a pressure point.

Finishing work

- Remove the motorcycle from the lift stand. (📖 p. 43)

14.5 Checking the tire condition

i Info

Only mount tires approved and/or recommended by KTM.

Other tires could have a negative effect on handling characteristics.

The type, condition, and pressure of the tires all have a major impact on the handling characteristic of the motorcycle.

The tires mounted on the front and rear wheels must have a similar profile.

Worn tires have a negative effect on handling characteristics, especially on wet surfaces.

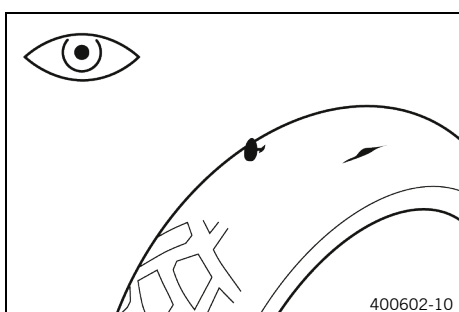

- Check the front and rear tires for cuts, embedded objects, and other damage.
 - » If the tires have cuts, run-in objects, or other damage:
 - Change the tires. 🛠️

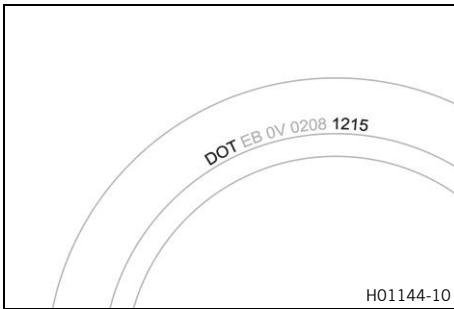

- Check the tire age.



Info

The tire date of manufacture is usually contained in the tire label and is indicated by the last four digits of the **DOT** number. The first two digits indicate the week of manufacture and the last two digits the year of manufacture.

KTM recommends that the tires be changed after 5 years at the latest, regardless of the actual state of wear.

- » If the tires are more than five years old:
 - Change the tires. 🛠️



14.6 Checking tire pressure



Info

Low tire pressure leads to abnormal wear and overheating of the tire. Correct tire pressure ensures optimal riding comfort and maximum tire service life.

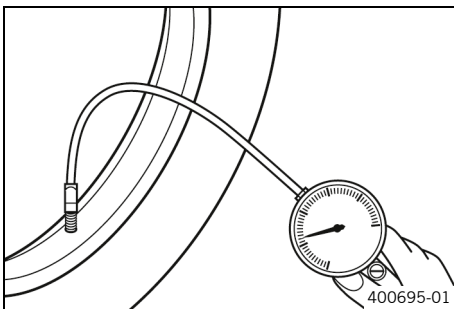

- Remove protection cap.
- Check tire pressure when the tires are cold.

Offroad tire pressure	
front	1.0 bar (15 psi)
rear	1.0 bar (15 psi)

- » If the tire pressure does not meet specifications:
 - Correct tire pressure.
- Mount the protection cap.



14.7 Checking the spoke tension



Warning

Danger of accidents Incorrectly tensioned spokes impair the handling characteristic and result in secondary damage.

The spokes break due to being overloaded if they are too tightly tensioned. If the tension in the spokes is too low, then lateral and radial run-out will form in the wheel. Other spokes will become looser as a result.

- Check spoke tension regularly, and in particular on a new vehicle. (Your authorized KTM workshop will be glad to help.)

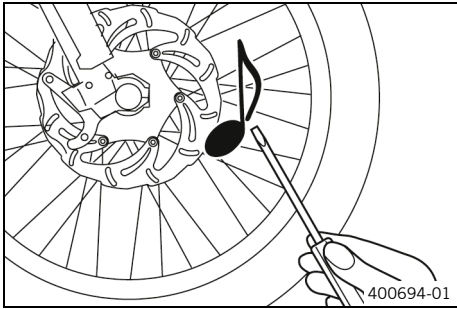

- Strike each spoke briefly using a screwdriver blade.

**Info**

The frequency of the sound depends on the spoke length and spoke diameter.

If spokes of the same length and diameter vibrate with a different tone, this is an indication that the spoke tensions differ.

You should hear a high note.

- » If the spoke tension differs:
 - Correct the spoke tension. 🛠️

- Check the spoke torque.

Guideline

Spoke nipple	M3.5	3 Nm (2.2 lbf ft)
--------------	------	-------------------

Torque wrench kit (58429094000)

15.1 Cooling system

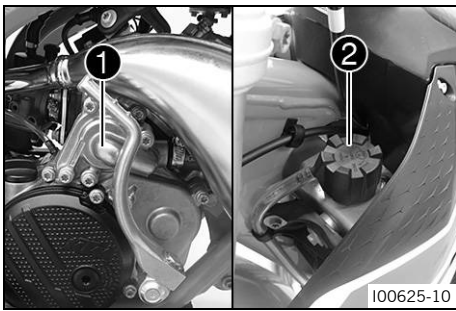

The water pump ① in the engine forces the coolant to flow. The pressure resulting from the warming of the cooling system is regulated by a valve in the radiator cap ②. This ensures that operating the vehicle at the specified coolant temperature will not result in a risk of malfunctions.

120 °C (248 °F)

Cooling is effected by the air stream. The lower the speed, the less the cooling effect. Dirty cooling fins also reduce the cooling effect.

15.2 Checking the antifreeze and coolant level



Warning

Danger of scalding During motorcycle operation, the coolant gets hot and is under pressure.

- Do not open the radiator, the radiator hoses or other cooling system components if the engine or the cooling system are at operating temperature.
- Allow the cooling system and the engine to cool down before you open the radiator, the radiator hoses or other components of the cooling system.
- In the event of scalding, rinse the area affected immediately with lukewarm water.



Warning

Danger of poisoning Coolant is harmful to health.

- Keep coolant out of the reach of children.
- Do not allow coolant to come into contact with the skin, the eyes and clothing.
- Consult a doctor immediately if coolant is swallowed.
- Rinse the affected area immediately with plenty of water in the event of contact with the skin.
- Rinse eyes thoroughly with water and consult a doctor immediately if coolant gets into the eyes.
- Change clothing if coolant spills onto your clothing.

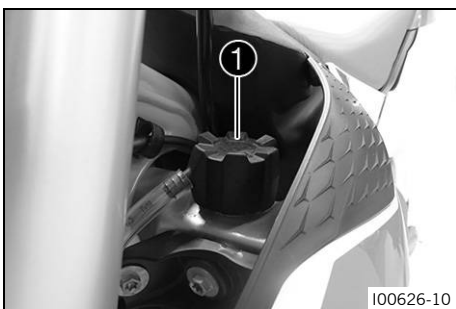

- Stand the motorcycle upright on a horizontal surface.
- Take off radiator cap ①.
- Check the antifreeze in the coolant.

-25 ... -45 °C (-13 ... -49 °F)

- » If the antifreeze in the coolant does not match the specified value:
 - Correct the antifreeze in the coolant.

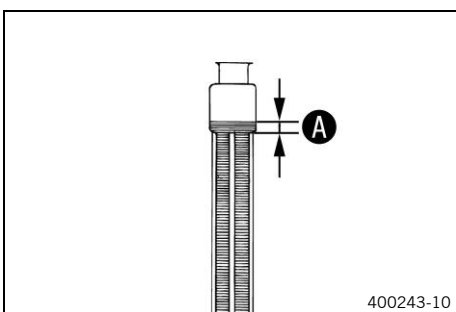

- Check the coolant level in the radiator.

Coolant level A above the radiator fins	10 mm (0.39 in)
---	-----------------

- » If the coolant level does not match the specified value:
 - Correct the coolant level.

Coolant (📖 p. 125)

- Mount the radiator cap.

15.3 Checking the coolant level



Warning

Danger of scalding During motorcycle operation, the coolant gets hot and is under pressure.

- Do not open the radiator, the radiator hoses or other cooling system components if the engine or the cooling system are at operating temperature.
- Allow the cooling system and the engine to cool down before you open the radiator, the radiator hoses or other components of the cooling system.
- In the event of scalding, rinse the area affected immediately with lukewarm water.



Warning

Danger of poisoning Coolant is harmful to health.

- Keep coolant out of the reach of children.
- Do not allow coolant to come into contact with the skin, the eyes and clothing.
- Consult a doctor immediately if coolant is swallowed.
- Rinse the affected area immediately with plenty of water in the event of contact with the skin.
- Rinse eyes thoroughly with water and consult a doctor immediately if coolant gets into the eyes.
- Change clothing if coolant spills onto your clothing.

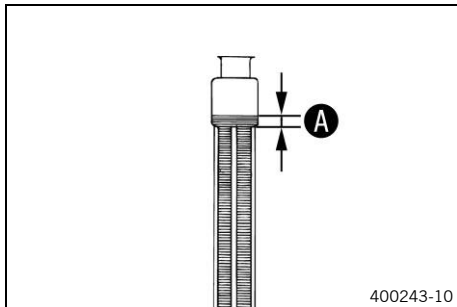

- Stand the motorcycle upright on a horizontal surface.
- Remove the radiator cap.
- Check the coolant level in the radiator.

Coolant level A above the radiator fins	10 mm (0.39 in)
--	-----------------

» If the coolant level does not match the specified value:

- Correct the coolant level.

Coolant (📖 p. 125)

- Mount the radiator cap.

15.4 Draining the coolant 🐉



Warning

Danger of scalding During motorcycle operation, the coolant gets hot and is under pressure.

- Do not open the radiator, the radiator hoses or other cooling system components if the engine or the cooling system are at operating temperature.
- Allow the cooling system and the engine to cool down before you open the radiator, the radiator hoses or other components of the cooling system.
- In the event of scalding, rinse the area affected immediately with lukewarm water.



Warning

Danger of poisoning Coolant is harmful to health.

- Keep coolant out of the reach of children.
- Do not allow coolant to come into contact with the skin, the eyes and clothing.
- Consult a doctor immediately if coolant is swallowed.
- Rinse the affected area immediately with plenty of water in the event of contact with the skin.
- Rinse eyes thoroughly with water and consult a doctor immediately if coolant gets into the eyes.
- Change clothing if coolant spills onto your clothing.

Condition

The engine is cold.

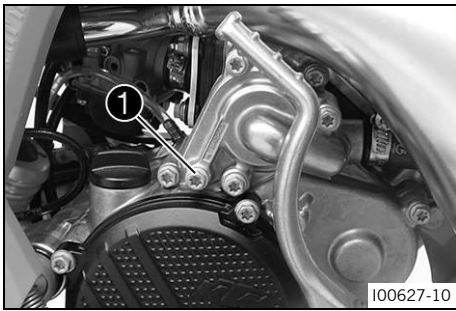

- Position the motorcycle upright.
- Place an appropriate container under the water pump cover.
- Remove screw ①. Take off the radiator cap.
- Completely drain the coolant.
- Mount and tighten screw ① with a new seal ring.

Guideline

Drain plug, water pump cover	M6	6 Nm (4.4 lbf ft)
------------------------------	----	-------------------

15.5 Refilling with coolant



Warning

Danger of poisoning Coolant is harmful to health.

- Keep coolant out of the reach of children.
- Do not allow coolant to come into contact with the skin, the eyes and clothing.
- Consult a doctor immediately if coolant is swallowed.
- Rinse the affected area immediately with plenty of water in the event of contact with the skin.
- Rinse eyes thoroughly with water and consult a doctor immediately if coolant gets into the eyes.
- Change clothing if coolant spills onto your clothing.

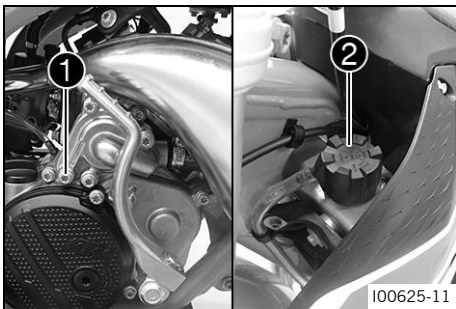

Main work

- Make sure that screw ① is tightened.
- Position the motorcycle upright.
- Take off radiator cap ②.
- Completely fill the radiator with coolant.

Coolant	0.7 l (0.7 qt.)	Coolant (📖 p. 125)
---------	-----------------	--------------------

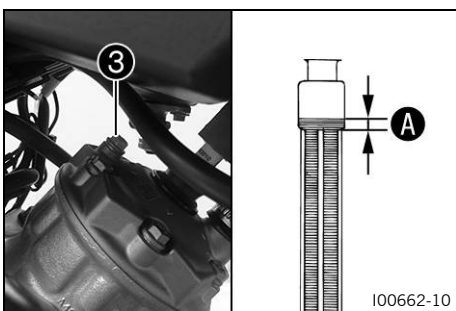

- Loosen screw ③ until coolant escapes without bubbles.
- Mount and tighten screw ③.

Guideline

Air release screw for coolant	M6	8 Nm (5.9 lbf ft)
-------------------------------	----	-------------------

- Add coolant to level A.

Guideline

Distance A above the radiator fins	10 mm (0.39 in)
------------------------------------	-----------------

Coolant	0.7 l (0.7 qt.)	Coolant (📖 p. 125)
---------	-----------------	--------------------

- Mount radiator cap ②.

Finishing work

- Go for a short test ride.
- Check the cooling system for leaks.

- Check the coolant level. (📖 p. 92)

15.6 Changing the coolant 🛠️



Warning

Danger of scalding During motorcycle operation, the coolant gets hot and is under pressure.

- Do not open the radiator, the radiator hoses or other cooling system components if the engine or the cooling system are at operating temperature.
- Allow the cooling system and the engine to cool down before you open the radiator, the radiator hoses or other components of the cooling system.
- In the event of scalding, rinse the area affected immediately with lukewarm water.



Warning

Danger of poisoning Coolant is harmful to health.

- Keep coolant out of the reach of children.
- Do not allow coolant to come into contact with the skin, the eyes and clothing.
- Consult a doctor immediately if coolant is swallowed.
- Rinse the affected area immediately with plenty of water in the event of contact with the skin.
- Rinse eyes thoroughly with water and consult a doctor immediately if coolant gets into the eyes.
- Change clothing if coolant spills onto your clothing.

Condition

The engine is cold.

- Position the motorcycle upright.
- Place an appropriate container under the water pump cover.
- Remove screw ❶. Take off radiator cap ❷.
- Completely drain the coolant.
- Mount and tighten screw ❶ with a new seal ring.

Guideline

Drain plug, water pump cover	M6	6 Nm (4.4 lbf ft)
------------------------------	----	-------------------

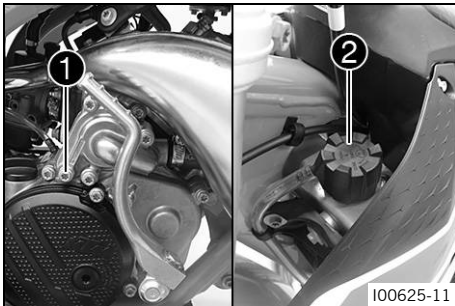

- Loosen screw ❸ until coolant escapes without bubbles.
- Mount and tighten screw ❸.

Guideline

Air release screw for coolant	M6	8 Nm (5.9 lbf ft)
-------------------------------	----	-------------------

- Add coolant to level A.

Guideline

Distance A above the radiator fins	10 mm (0.39 in)
------------------------------------	-----------------

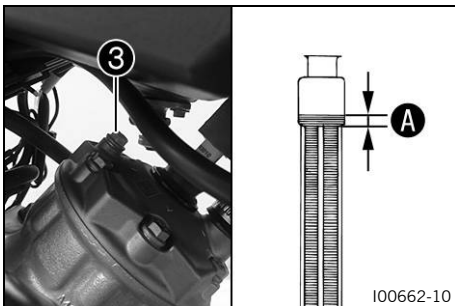

Coolant	0.7 l (0.7 qt.)	Coolant (📖 p. 125)
---------	-----------------	--------------------

- Mount radiator cap ❷.

Finishing work

- Go for a short test ride.
- Check the cooling system for leaks.
- Check the coolant level. (📖 p. 92)



16.1 Checking the play in the throttle cable

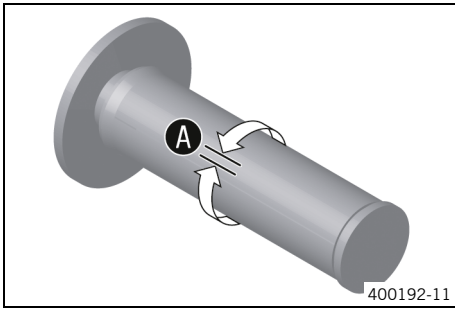

- Check the throttle grip for smooth operation.
- Move the handlebar to the straight-ahead position. Turn the throttle grip back and forth slightly and determine the play in throttle cable **A**.

Play in throttle cable	3 ... 5 mm (0.12 ... 0.2 in)
------------------------	------------------------------

- » If the throttle cable play does not meet the specified value:
 - Adjust the play in the throttle cable. 🛠️ (📖 p. 96)



Danger

Danger of poisoning Exhaust gases are toxic and inhaling them may result in unconsciousness and death.

- Always make sure there is sufficient ventilation when running the engine.
- Use effective exhaust extraction when starting or running the engine in an enclosed space.

- Start the engine and let it run at idle speed. Move the handlebar to and fro over the entire steering range.

The idle speed must not change.

- » If the idle speed changes:
 - Adjust the play in the throttle cable. 🛠️ (📖 p. 96)

16.2 Adjusting the play in the throttle cable 🛠️

Preparatory work

- Remove the seat. (📖 p. 59)
- Turn the knurled screw on the fuel tap all the way clockwise.
- Remove the fuel tank. 🛠️ (📖 p. 51)
- Check the throttle cable routing. (📖 p. 69)

Main work

- Move the handlebar to the straight-ahead position.
- Push back sleeve **1**.
- Ensure that the throttle cable sleeve is pushed all the way into barrel adjuster **2**.
- Loosen nut **3**.

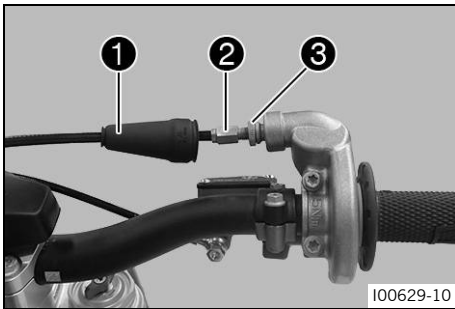

- Turn barrel adjuster **2** so that there is play **A** in the throttle cable at the throttle grip.

Guideline

Play in throttle cable	3 ... 5 mm (0.12 ... 0.2 in)
------------------------	------------------------------

- Tighten nut **3**.
- Slide on sleeve **1**.

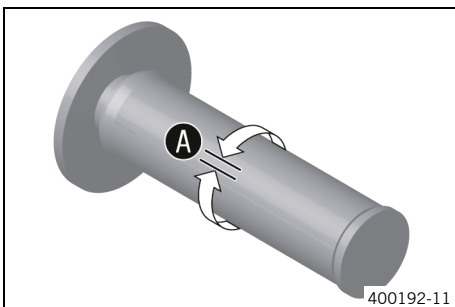

Finishing work

- Install the fuel tank. (🔧 p. 52)
- Mount the seat. (🔧 p. 59)
- Check the play in the throttle cable. (🔧 p. 96)



16.3 Carburetor – idle setting

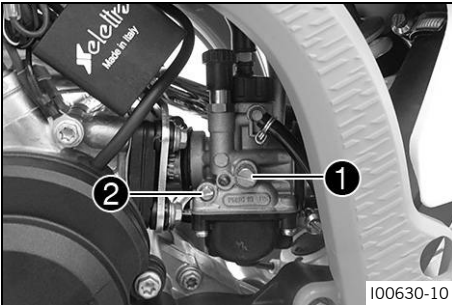

The idle setting of the carburetor has a big influence on the starting behavior, stable idle speed, and the response to throttle opening. This means that an engine with a correctly set idle speed will be easier to start than one with an incorrectly set idle speed.

i Info
The carburetor and its components are subject to increased wear caused by engine vibration. Wear can result in malfunctioning.

The idle speed is adjusted using the idle speed adjusting screw **1**.

The idle mixture is adjusted using the idle air adjusting screw **2**.

16.4 Carburetor – adjusting the idle speed 🛠️

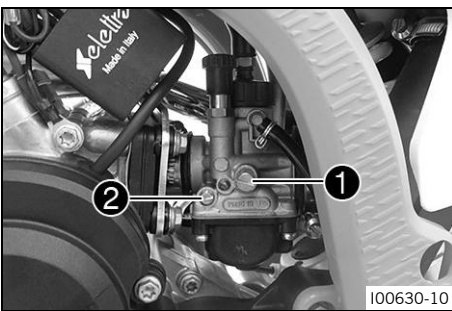

- Screw in idle air adjusting screw **2** all the way and turn it to the specified basic setting.

Guideline

Idle air adjusting screw	
Open	3 turns

- Run the engine until warm.

Guideline

Warming-up phase	≥ 5 min
------------------	---------

- Connect the special tool.

Service hour counter with revolution counter (A54012920100)

⚠️ Danger
Danger of poisoning Exhaust gases are toxic and inhaling them may result in unconsciousness and death.

- Always make sure there is sufficient ventilation when running the engine.
- Use effective exhaust extraction when starting or running the engine in an enclosed space.

- Adjust the idle speed using idle speed adjusting screw **1**.

Guideline

Choke function deactivated – The choke lever is pushed in to the stop. (🔧 p. 16)	
Idle speed	1,700 ... 2,000 rpm

- Turn idle air adjusting screw **2** slowly in a clockwise direction until the idle speed begins to fall.

- Note the position and turn the idle air adjusting screw slowly counterclockwise until the idle speed again begins to fall.
- Adjust to the point between these two positions with the highest idle speed.



Info

If there is a big engine speed rise, reduce the idle speed to a normal level and repeat the above steps. If the procedure described here does not lead to satisfactory results, the cause may be a wrongly dimensioned idling jet.

If you can turn the idle air adjusting screw to the end without any change of engine speed, mount a smaller idling jet.

After changing the idling jet, start from the beginning with the adjusting steps.

Following extreme air temperature or altitude changes, adjust the idle speed again.

16.5 Checking the clutch setting

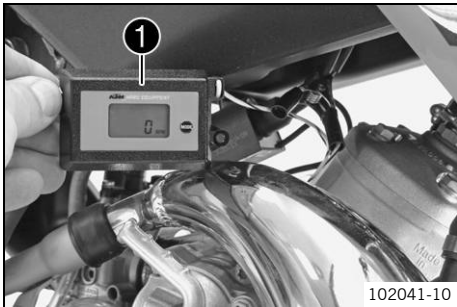

102041-10

- Connect special tool ①.

Service hour counter with revolution counter (A54012920100)

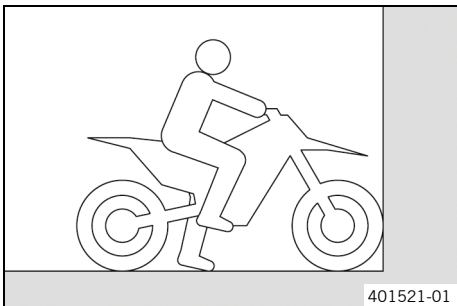

401521-01

- Let the front wheel of the vehicle make contact with a fixed object.



Danger

Danger of poisoning Exhaust gases are toxic and inhaling them may result in unconsciousness and death.

- Always make sure there is sufficient ventilation when running the engine.
- Use effective exhaust extraction when starting or running the engine in an enclosed space.

- Start the motorcycle.
- Only ride full throttle to the point where the maximum engine speed is reached.

Guideline

Operation at full throttle	≤ 3 s
----------------------------	-------

- Read the speed.

Slip speed	9,800 ... 10,400 rpm
------------	----------------------

- » If the specified value is not reached:
 - Adjust the clutch. 🛠️ (p. 99)

16.6 Removing the clutch cover 🛠️



Note

Environmental hazard Improper handling of fuel is a danger to the environment.

- Do not allow fuel to enter the groundwater, the soil, or the sewage system.



Info

Fuel can emerge via the carburetor.

Capture emerging fuel using a suitable container.

- Turn the knurled screw on the fuel tap all the way clockwise.
- Lay the vehicle down on its left side.
- Remove screws ①.
- Remove clutch cover ② with the seal ring.

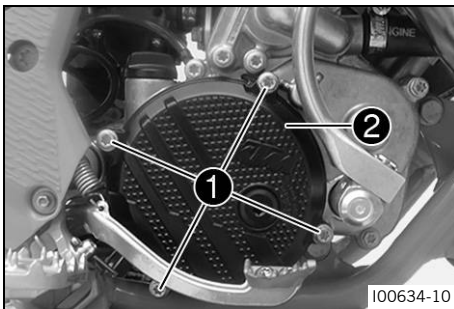

16.7 Adjusting the clutch 🛠️

Preparatory work

Condition

Clutch cover remains fitted

- Raise the motorcycle with a lift stand. (🛠️ p. 43)

Condition

Clutch cover is removed

- Remove the clutch cover. 🛠️ (📖 p. 99)

Condition

Clutch cover remains fitted

- Remove plug ① and the seal ring.

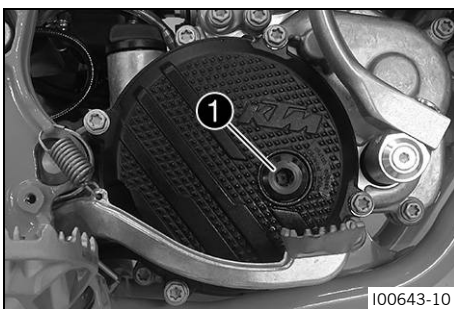

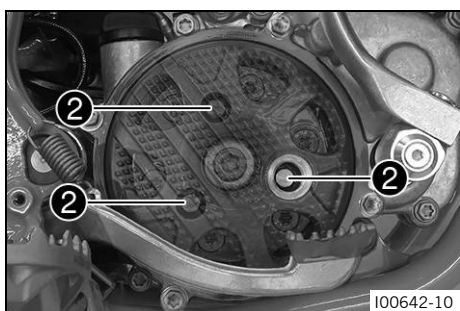
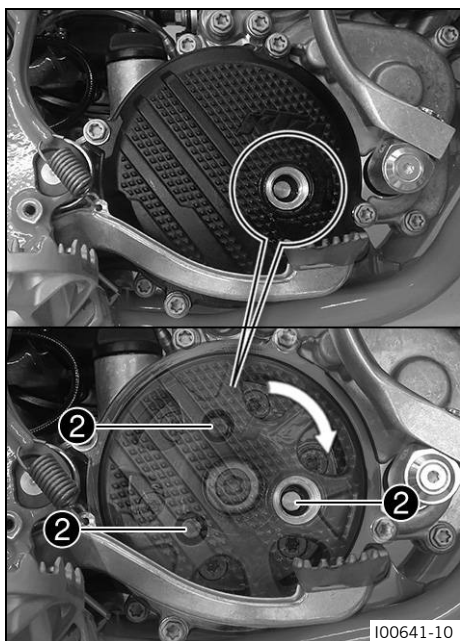

- Turn the clutch basket until adjusting screws ② become accessible.

i Info
The clutch basket is turned with the kick starter lever.
Adjusting screws ② are turned with the rear wheel.

Condition

If there is no reference point:

- Turn adjusting screws ② counterclockwise to the last detectable click.
- Turn adjusting screws ② clockwise by 8 clicks to the basic setting.

Guideline

Basic setting of slip speed	9,800 ... 10,400 rpm
-----------------------------	----------------------

i Info
The springs may not be pretensioned by more than 14 clicks from the stop using the adjusting screws.
If 15 clicks or more are preloaded, the clutch can become tense and can no longer be reset. The clutch must be dismantled.

Condition

If the slip speed is too low:

- Turn adjusting screws ② clockwise.

Guideline

1 click increases the slip speed by	200 ... 300 rpm
-------------------------------------	-----------------

i Info
The springs may not be pretensioned by more than 14 clicks from the stop using the adjusting screws.

Condition

If the slip speed is too high:

- Turn adjusting screws ② counterclockwise.

Guideline

1 click decreases the slip speed by	200 ... 300 rpm
-------------------------------------	-----------------

- Mount and tighten plug **1** with a new seal ring.

Guideline

Screw, gear oil level monitoring	M14x1.25	10 Nm (7.4 lbf ft)
----------------------------------	----------	-----------------------

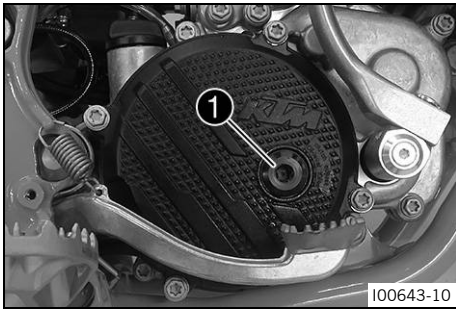

I00643-10

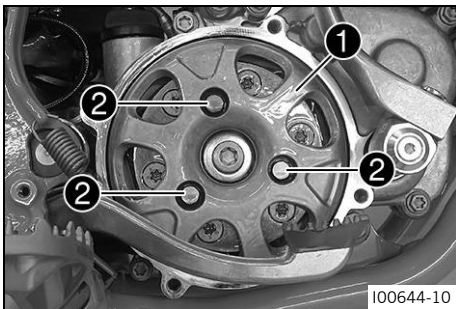

I00644-10

Condition

Clutch cover is removed

- Turn clutch basket **1** until adjusting screws **2** become accessible.

i Info

Clutch basket **1** is turned with the kick starter lever.

Adjusting screws **2** are turned with the rear wheel.

Condition

If there is no reference point:

- Turn adjusting screws **2** counterclockwise to the last detectable click.
- Turn adjusting screws **2** clockwise by 8 clicks to the basic setting.

Guideline

Basic setting of slip speed	9,800 ... 10,400 rpm
-----------------------------	----------------------

i Info

The springs may not be pretensioned by more than 14 clicks from the stop using the adjusting screws.

If 15 clicks or more are preloaded, the clutch can become tense and can no longer be reset. The clutch must be dismantled.

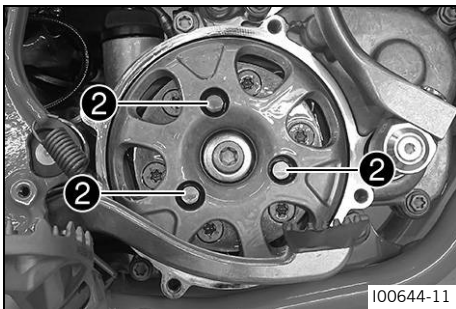

I00644-11

Condition

If the slip speed is too low:

- Turn adjusting screws **2** clockwise.

Guideline

1 click increases the slip speed by	200 ... 300 rpm
-------------------------------------	-----------------

i Info

The springs may not be pretensioned by more than 14 clicks from the stop using the adjusting screws.

Condition

If the slip speed is too high:

- Turn adjusting screws **2** counterclockwise.

Guideline

1 click decreases the slip speed by	200 ... 300 rpm
-------------------------------------	-----------------

Finishing work

Condition

Clutch cover remains fitted

- Remove the motorcycle from the lift stand. (📖 p. 43)

Condition

Clutch cover is removed

- Install the clutch cover. 🛠️ (📖 p. 102)
- Check the gear oil level. (📖 p. 103)
- Check the clutch setting. 🛠️ (📖 p. 98)

16.8 Installing the clutch cover 🛠️

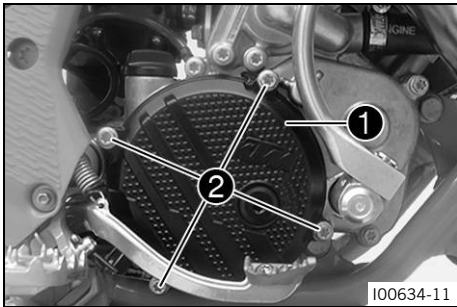

Main work

- Position the clutch cover **1** with the seal ring.
- Mount and tighten screws **2**.

Guideline

Screw, outer clutch cover	M6	10 Nm (7.4 lbf ft)
---------------------------	----	--------------------

Finishing work

- Check the gear oil level. (📖 p. 103)

17.1 Checking the gear oil level

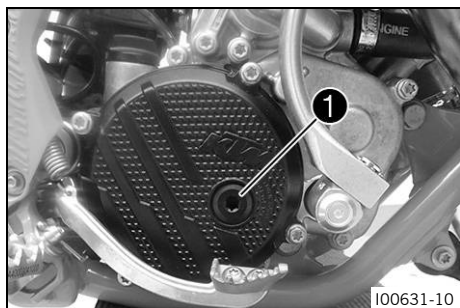

Condition

The engine is cold.

Preparatory work

- Stand the motorcycle upright on a horizontal surface.

Main work

- Remove screw ① with the seal ring.
- Check the gear oil level.

Gear oil must not run out of the hole.
--

The gear oil level is at the lower edge of the hole.
--

- » If the gear oil level is below the hole:
 - Add the gear oil. 🛠️ (p. 104)
- » If gear oil runs out:
 - Correct the gear oil level.

- Mount and tighten screw ① with the seal ring.

Guideline

Screw, gear oil level monitoring	M14x1.25	10 Nm (7.4 lbf ft)
----------------------------------	----------	--------------------

17.2 Changing the gear oil 🛠️



Warning

Danger of scalding Engine and gear oil get hot when the motorcycle is operated.

- Wear suitable protective clothing and safety gloves.
- In the event of scalding, rinse the area affected immediately with lukewarm water.



Note

Environmental hazard Hazardous substances cause environmental damage.

- Dispose of oils, grease, filters, fuel, cleaning agents, brake fluid, etc., correctly and in compliance with the applicable regulations.



Info

Drain gear oil with engine at operating temperature.

Preparatory work

- Stand the motorcycle on the plug-in stand on a horizontal surface.

Main work

- Position an appropriate container under the engine.
- Remove oil drain plug ① with the magnet.
- Let the gear oil drain fully.
- Thoroughly clean the oil drain plug with magnet.
- Clean the sealing surface on the engine.
- Mount and tighten the oil drain plug with the magnet and new seal ring.

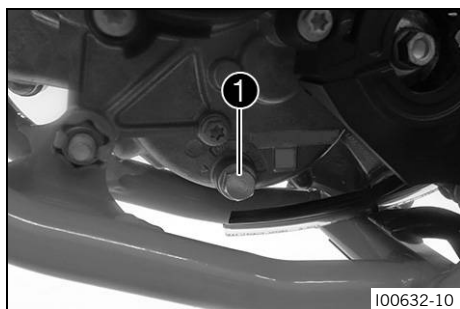

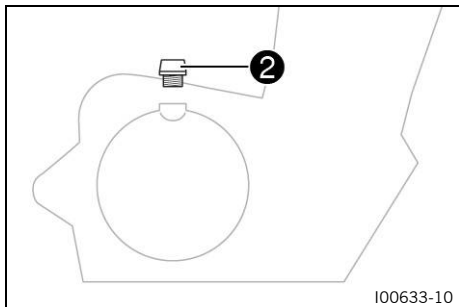

Guideline

Oil drain plug with magnet	M12x1.5	20 Nm (14.8 lbf ft)
----------------------------	---------	---------------------

- Remove filler plug ② with the O-ring, and fill up with gear oil.

Gear oil	0.20 l (0.21 qt.)	Gear oil (ATF Dexron 3) (📖 p. 126)
----------	----------------------	--

i Info

Too little gear oil or poor-quality gear oil results in premature wear to the transmission.

- Mount and tighten filler plug ② together with the O-ring.



Danger

Danger of poisoning Exhaust gases are toxic and inhaling them may result in unconsciousness and death.

- Always make sure there is sufficient ventilation when running the engine.
- Use effective exhaust extraction when starting or running the engine in an enclosed space.

- Start the engine and check it for leaks.

Finishing work

- Check the gear oil level. (📖 p. 103)

17.3 Adding the gear oil ↩

i Info

Too little gear oil or poor-quality gear oil results in premature wear to the transmission.

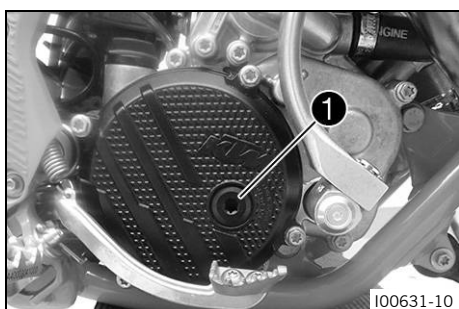

Preparatory work

- Stand the motorcycle upright on a horizontal surface.

Main work

- Remove gear oil level monitoring screw ①.

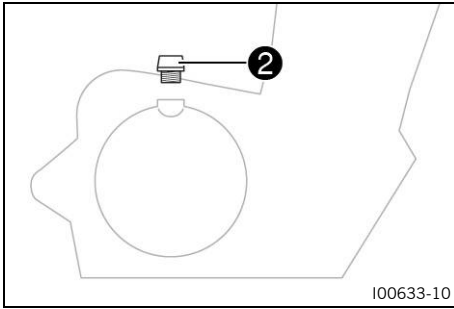

- Remove filler plug ② with the O-ring.
- Add gear oil until it flows out of the hole of the gear oil level plug.

Gear oil (ATF Dexron 3) (📖 p. 126)

- Mount and tighten gear oil level monitoring screw ①.

Guideline

Screw, gear oil level monitoring	M14x1.25	10 Nm (7.4 lbf ft)
----------------------------------	----------	--------------------

- Mount and tighten filler plug ② together with the O-ring.



Danger

Danger of poisoning Exhaust gases are toxic and inhaling them may result in unconsciousness and death.

- Always make sure there is sufficient ventilation when running the engine.
- Use effective exhaust extraction when starting or running the engine in an enclosed space.

- Start the engine and check it for leaks.



18.1 Removing the carburetor



Danger

Fire hazard Fuel is highly flammable.

The fuel in the fuel tank expands when warm and can escape if overfilled.

- Do not fuel the vehicle in the vicinity of open flames or lit cigarettes.
- Switch off the engine for refueling.
- Make sure that no fuel is spilled; particularly not on hot parts of the vehicle.
- If any fuel is spilled, wipe it off immediately.
- Observe the specifications for refueling.











Warning

Danger of poisoning Fuel is harmful to health.

- Avoid skin, eye and clothing contact with fuel.
- Immediately consult a doctor if you swallow fuel.
- Do not inhale fuel vapors.
- Rinse the affected area immediately with plenty of water in the event of contact with the skin.
- Rinse the eyes thoroughly with water, and consult a doctor in case of fuel contact with the eyes.
- Change your clothing if fuel spills on them.
- Keep fuels correctly in a suitable canister, and out of the reach of children.

Preparatory work

- Raise the motorcycle with a lift stand. ( p. 43)
- Remove the seat. ( p. 59)
- Turn the knurled screw on the fuel tap all the way clockwise.
- Remove the fuel tank.  ( p. 51)
- Remove the right side cover. ( p. 56)
- Remove main silencer. ( p. 61)
- Remove the frame protector. ( p. 59)
- Remove the left side cover. ( p. 55)
- Remove the right side cover. ( p. 56)

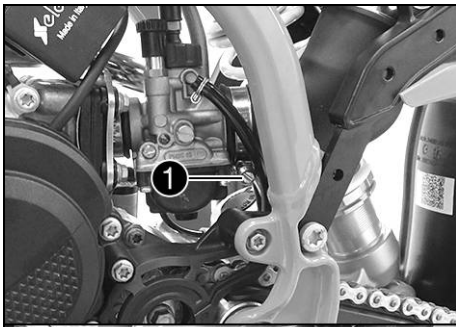

Main work

- Loosen hose clips **1** and **2**.

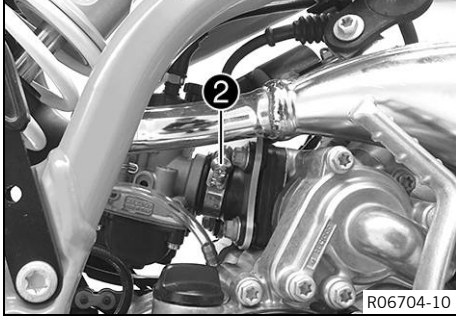

R06704-10

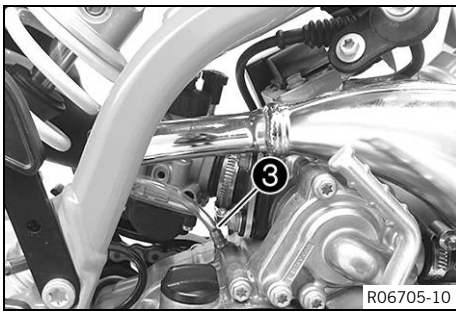

R06705-10

- Pull off vent hose **3**.

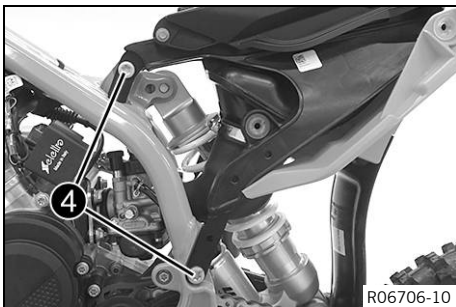

R06706-10

- Remove screws **4**.
- Repeat the operation on the opposite side.
- Remove subframe with the fender.



Info

Watch out for the intake flange.

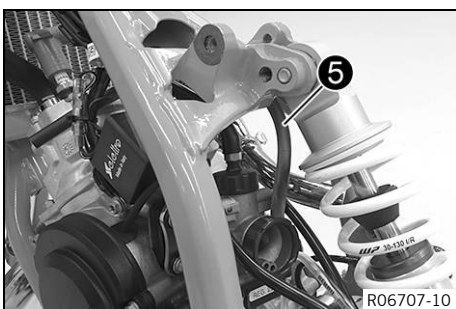

R06707-10

- Take fuel line **5** out of the guide.

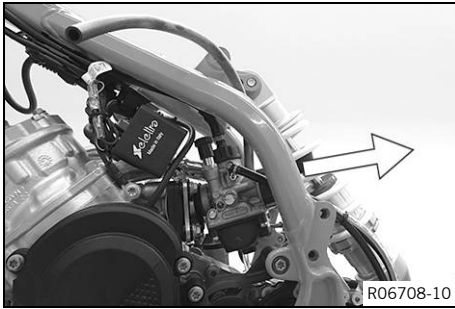

- Pull the carburetor back toward the rear.

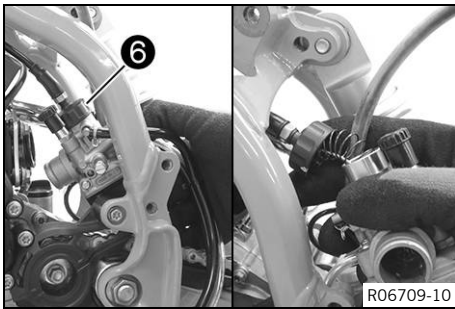

- Open throttle slide cover ⑥.
- Pull the throttle slide out of the carburetor.
- Drain the remaining fuel.

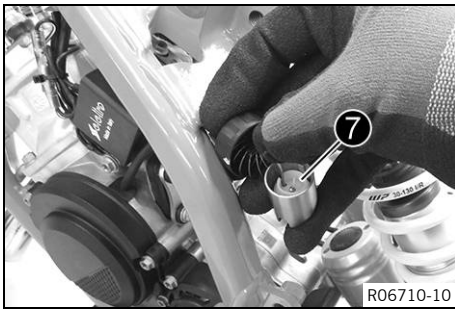

- Pull throttle slide spring back.
- Push spring retainer ⑦ back.

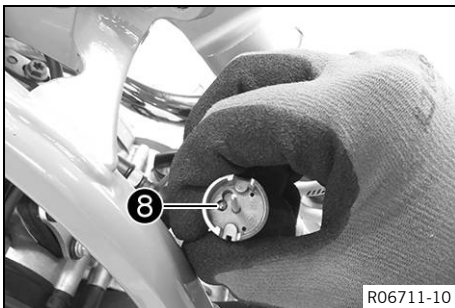

- Detach throttle cable wire ⑧.
- Take off the throttle slide.

18.2 Installing the carburetor ↩

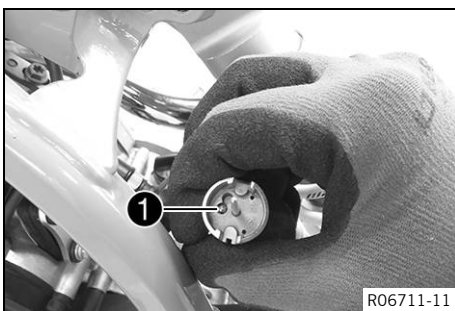

Main work

- Attach throttle cable wire ①.

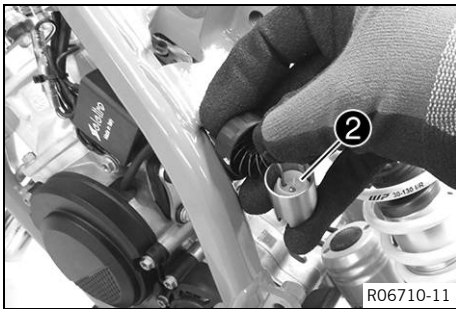

- Position spring retainer **2** and the throttle slide spring.

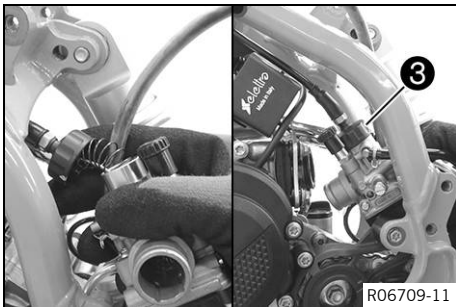

- Position the throttle slide and the throttle slide cover.
- Tighten throttle slide cover **3** hand-tight.
- Measure the distance between the carburetor housing and the throttle slide cover.
 - » Distance: ≤ 3 mm (≤ 0.12 in)
 - If the specified value is not reached:
 - Screw on the throttle slide cover correctly.

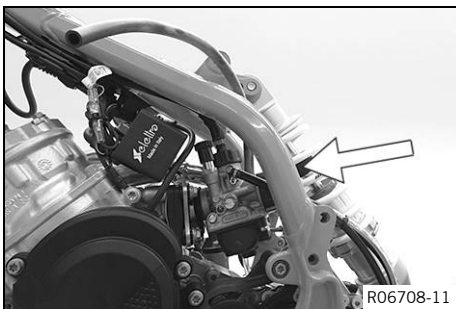

- Mount the carburetor.

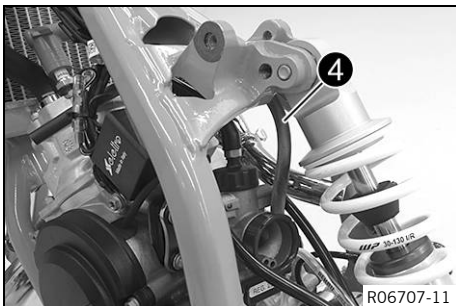

- Position fuel hose **4** in the guide.

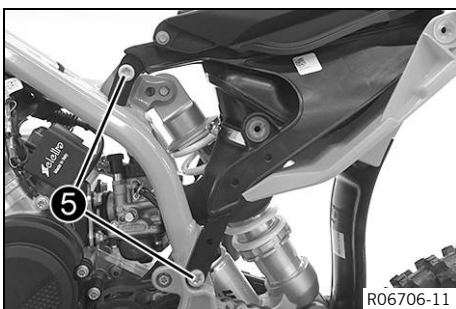

- Position the subframe.



Info

Watch out for the intake flange.

- Mount and tighten screws **5**.

Guideline

Remaining screws, chassis	M8	25 Nm (18.4 lbf ft)
---------------------------	----	---------------------

- Repeat the operation on the opposite side.

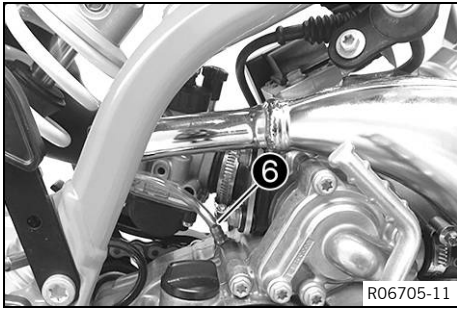

- Mount vent hose ⑥.

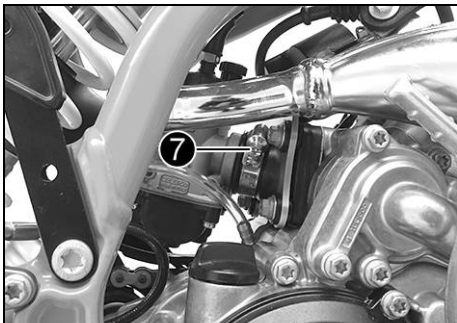

- Position and tighten hose clips ⑦ and ⑧.

Guideline

Hose clip, carburetor	-	2.8 Nm (2.07 lbf ft)
-----------------------	---	-------------------------

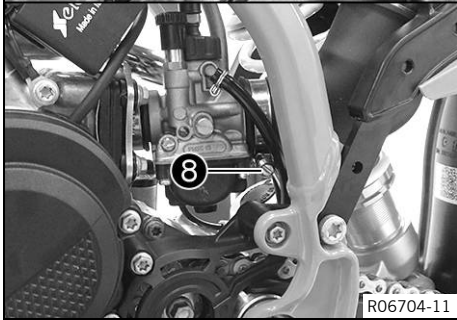

Finishing work

- Check the play in the throttle cable. (📖 p. 96)
- Install the main silencer. (📖 p. 62)
- Install the right side cover. (📖 p. 57)
- Install the left side cover. (📖 p. 56)
- Carburetor – adjust the idle speed. 🛠️ (📖 p. 97)
- Install the frame protector. (📖 p. 60)
- Install the fuel tank. 🛠️ (📖 p. 52)
- Mount the seat. (📖 p. 59)
- Remove the motorcycle from the lift stand. (📖 p. 43)

19.1 Cleaning the motorcycle

Note

Material damage Components become damaged or destroyed if a pressure cleaner is used incorrectly.

The high pressure forces water into the electrical components, connectors, throttle cables, and bearings, etc. Pressure which is too high causes malfunctions and destroys components.

- Do not direct the water jet directly on to electrical components, connectors, throttle cables or bearings.
- Maintain a minimum distance between the nozzle of the pressure cleaner and the component.
Minimum clearance 60 cm (23.6 in)



Note

Environmental hazard Hazardous substances cause environmental damage.

- Dispose of oils, grease, filters, fuel, cleaning agents, brake fluid, etc., correctly and in compliance with the applicable regulations.



Info

Clean the motorcycle regularly to maintain its value and appearance over a long period. Avoid direct sunshine when cleaning the motorcycle.

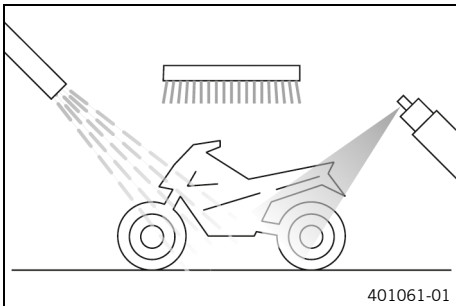

- Close off exhaust system to keep water from entering.
- Remove loose dirt first with a soft jet of water.
- Spray the heavily soiled parts with a normal commercial motorcycle cleaner and clean using a brush.

Motorcycle cleaner (📖 p. 127)



Info

Use warm water containing normal motorcycle cleaner and a soft sponge. Never apply motorcycle cleaner to a dry vehicle; always rinse the vehicle with water first.

- After rinsing the motorcycle with a gentle spray of water, allow it to dry thoroughly.
- Remove the closure of the exhaust system.
- Empty the carburetor float chamber. 🗑️



Warning

Danger of accidents Moisture and dirt impair the brake system.

- Explain to your child that he or she must brake carefully several times to dry out and remove dirt from the brake linings and the brake discs.

- After cleaning, your child should ride the vehicle a short distance until the engine warms up and until the brakes system has dried through careful application of the brakes.



Info

The heat produced causes water at inaccessible locations in the engine and on the brake system to evaporate.

- Push back the protection caps on the handlebar controls to allow water to evaporate.
- After the motorcycle has cooled down, lubricate all moving parts and pivot points.
- Clean the chain. (📖 p. 64)
- Treat bare metal (except for brake discs and the exhaust system) with a corrosion inhibitor.

Preserving materials for paints, metal and rubber
(📖 p. 127)

- Treat all plastic parts and powder-coated parts with a mild cleaning and care product.

Special cleaner for glossy and matte paint finishes, metal and plastic surfaces (📖 p. 128)

20.1 Storage

**Warning****Danger of poisoning** Fuel is harmful to health.

- Avoid skin, eye and clothing contact with fuel.
- Immediately consult a doctor if you swallow fuel.
- Do not inhale fuel vapors.
- Rinse the affected area immediately with plenty of water in the event of contact with the skin.
- Rinse the eyes thoroughly with water, and consult a doctor in case of fuel contact with the eyes.
- Change your clothing if fuel spills on them.
- Keep fuels correctly in a suitable canister, and out of the reach of children.

**Info**

If the motorcycle is not being used for an extended length of time, additional measures are recommended. Before storing the motorcycle, check all parts for function and wear. If service, repairs, or replacements are necessary, you should do this during the storage period (less workshop overload). This allows you to avoid long waiting periods when the next season starts.

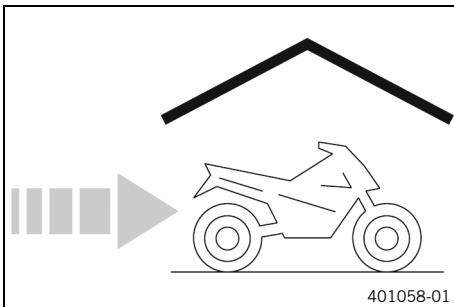

- When refueling for the last time before taking the motorcycle out of service, add fuel additive.

Fuel additive (📖 p. 127)

- Refuel. (📖 p. 24)

**Tip**

Fill the fuel tank completely as specified, using fuel with the lowest possible ethanol content.

- Clean the motorcycle. (📖 p. 111)
- Change the gear oil. 🛠️ (📖 p. 103)
- Check the antifreeze and coolant level. (📖 p. 91)
- Empty the carburetor float chamber. 🛠️
- Check tire pressure. (📖 p. 89)
- Store the vehicle in a dry location that is not subject to large fluctuations in temperature.

**Info**

KTM recommends jacking up the motorcycle.

- Raise the motorcycle with a lift stand. (📖 p. 43)
- Cover the motorcycle with a tarp or cover that is permeable to air.

**Info**

Do not use non-porous materials since they prevent humidity from escaping, thus causing corrosion. Avoid running the engine for a short time only. Because the engine will not warm up sufficiently, the water vapor produced during combustion will condense, causing engine parts and the exhaust system to rust.

20.2 Preparing for use after storage

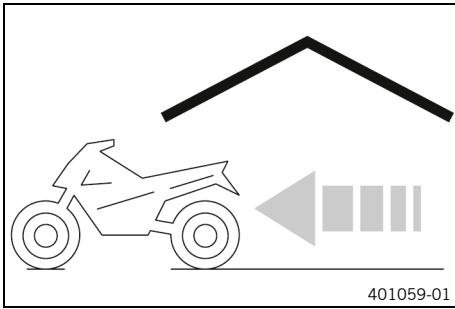

- Remove the motorcycle from the lift stand. (📖 p. 43)
- Perform checks and maintenance measures when preparing for use. (📖 p. 21)
- Take a test ride.

Faults	Possible cause	Action
Engine turns but does not start	Operating error	– Carry out start procedure. (🔊 p. 21)
	Motorcycle was out of use for a long time and there is old fuel in the float chamber	– Empty the carburetor float chamber. 🛠️
	Fuel supply interrupted	– Check the fuel tank breather. – Clean the fuel tap. – Check/set the carburetor components. 🛠️
	Spark plug sooty or wet	– Clean and dry the spark plug and spark plug connector, or change if necessary.
	Plug gap of spark plug too wide	– Adjust plug gap. Guideline Spark plug electrode gap 0.70 mm (0.0276 in)
	Fault in ignition system	– Check the ignition system. 🛠️
	Short-circuit cable in wiring harness frayed, stop button faulty	– Check the stop button. 🛠️
	The connector or ignition coil is loose or oxidized	– Clean the plug-in connection and treat it with contact spray.
	Water in carburetor or jets blocked	– Check/set the carburetor components. 🛠️
Engine has no idle speed	Idling jet blocked	– Check/set the carburetor components. 🛠️
	Adjusting screws on the carburetor are in turned to the wrong position	– Carburetor – adjust the idle speed. 🛠️ (🔊 p. 97)
	Spark plug defective	– Change spark plug.
	Ignition system defective	– Check the ignition coil. 🛠️ – Check the spark plug connector. 🛠️
Engine does not speed up	The carburetor is flowing over because the float needle is dirty or worn	– Check/set the carburetor components. 🛠️
	Loose carburetor jets	– Check/set the carburetor components. 🛠️
	Fault in ignition system	– Check the ignition system. 🛠️
Engine has too little power	Fuel supply interrupted	– Check the fuel tank breather. – Clean the fuel tap. – Check/set the carburetor components. 🛠️
	Air filter very dirty	– Clean the air filter and air filter box. 🛠️ (🔊 p. 61)
	Exhaust system leaky, deformed or too little glass fiber yarn filling in main silencer	– Check exhaust system for damage. – Change the rock wool on the main silencer. 🛠️ (🔊 p. 62)
	Ignition system defective	– Check the ignition coil. 🛠️ – Check the spark plug connector. 🛠️
	Diaphragm or reed valve housing damaged	– Check the diaphragm and reed valve housing.

Faults	Possible cause	Action
Engine has too little power	Noticeable wear	– Overhaul the engine.
	Clutch engagement speed too low or too high	– Check the clutch setting. 🛠️ (📖 p. 98)
Engine stalls or is popping into the carburetor	Lack of fuel	– Turn the knurled screw on the fuel tap all the way counterclockwise. – Refuel. (📖 p. 24)
	Engine takes in bad air	– Check the intake flange and carburetor for tightness.
	The connector or ignition coil is loose or oxidized	– Clean the plug-in connection and treat it with contact spray.
Engine overheats	Too little coolant in cooling system	– Check the cooling system for leakage. – Check the coolant level. (📖 p. 92)
	Too little air stream	– Switch off engine when standing.
	Radiator fins very dirty	– Clean radiator fins.
	Foam formation in cooling system	– Drain the coolant. 🛠️ (📖 p. 92) – Refill with coolant. 🛠️ (📖 p. 93)
	Damaged cylinder head or cylinder head gasket	– Check the cylinder head or cylinder head gasket.
	Bent radiator hose	– Change the radiator hose. 🛠️
White smoke emission (steam in exhaust gas)	Damaged cylinder head or cylinder head gasket	– Check the cylinder head or cylinder head gasket.
Gear oil exits at the vent hose	Too much gear oil added	– Check the gear oil level. (📖 p. 103)
Water in the gear oil	Damaged radial shaft seal ring or water pump	– Check the radial shaft seal ring and the water pump.

22.1 Engine

Design	1-cylinder 2-stroke engine, water-cooled, with reed intake
Displacement	49.9 cm ³ (3.045 cu in)
Stroke	40.7 mm (1.602 in)
Bore	39.5 mm (1.555 in)
Crankshaft bearing	2 grooved ball bearings
Conrod bearing	Needle bearing
Piston pin bearing	Needle bearing
Pistons	Aluminum cast
Piston rings	1 rectangular ring
Engine lubrication	Mixed lubrication
Primary transmission	33:61 straight cut spur gear drive
Clutch	Multi-disc centrifugal force clutch
Gearbox	Rigid 1-stage reduction gear
Transmission ratio	14:31
Ignition	Selettra Digital
Spark plug (50 SX)	BRISK AR10C (Standard), BRISK AR10IR (recommended for competition use)
Spark plug (FACTORY EDITION)	BRISK AR10IR
Spark plug electrode gap	0.70 mm (0.0276 in)
Cooling	Water-cooled
Starting aid	Kick starter system

22.2 Engine tightening torques

Nut, water pump impeller	M5	5 Nm (3.7 lbf ft) Loctite®243™
Screw, bearing retainer	M5	5 Nm (3.7 lbf ft) Loctite®243™
Screw, kick starter lever	M5	6 Nm (4.4 lbf ft) Loctite®243™
Screw, stator bracket	M5	6 Nm (4.4 lbf ft) Loctite®243™
Air release screw for coolant	M6	8 Nm (5.9 lbf ft)
Drain plug, water pump cover	M6	8 Nm (5.9 lbf ft)
Screw, alternator cover	M6	6 Nm (4.4 lbf ft)
Screw, cylinder head	M6x25	10 Nm (7.4 lbf ft)
Screw, engine case	M6	10 Nm (7.4 lbf ft)
Screw, engine sprocket	M6	10 Nm (7.4 lbf ft) Loctite®2701™
Screw, exhaust flange	M6	10 Nm (7.4 lbf ft) Loctite®243™
Screw, fitting pin	M6	10 Nm (7.4 lbf ft) Loctite®2701™
Screw, ground wire	M6	10 Nm (7.4 lbf ft)

Screw, ignition coil	M6	8 Nm (5.9 lbf ft) Loctite®243™
Screw, inner clutch cover	M6	10 Nm (7.4 lbf ft)
Screw, intake flange	M6	5 Nm (3.7 lbf ft) Loctite®243™
Screw, outer clutch cover	M6	10 Nm (7.4 lbf ft)
Screw, pressure plate	M6	10 Nm (7.4 lbf ft) Loctite®243™
Screw, water pump cover	M6	10 Nm (7.4 lbf ft)
Vacuum connection (housing breather)	M6	4 Nm (3 lbf ft) Loctite®243™
Nuts, cylinder base	M8	20 Nm (14.8 lbf ft)
Screw, clutch basket	M8	35 Nm (25.8 lbf ft) Loctite®243™
Screw, cylinder base	M8x41	7 Nm (5.2 lbf ft)
Spark plug	M10x1	13 Nm (9.6 lbf ft)
Nut, primary gear wheel	M10x1.25	40 Nm (29.5 lbf ft) Loctite®243™
Nut, rotor	M10x1.25	15 Nm (11.1 lbf ft) Loctite®243™
Oil drain plug with magnet	M12x1.5	20 Nm (14.8 lbf ft)
Screw, gear oil level monitoring	M14x1.25	10 Nm (7.4 lbf ft)

22.3 Carburetor with carburetor tuning

Carburetor type	Dell'Orto PHBG 19BS
Needle position	2nd position from top
Idle air adjusting screw	
Open	3 turns
Main jet	88 (85, 90, 92)
Jet needle	W7
Idling jet	50
Needle jet	262AU
Throttle slide	40
Choke nozzle	65

22.3.1 Carburetor tuning (Option: Low seat position)

Dell'Orto PHBG19 BS

ASL	TEMP	-20 ... -7 °C (-4 ... 19 °F)	-6 ... 5 °C (21 ... 41 °F)	6 ... 15 °C (43 ... 59 °F)	16 ... 24 °C (61 ... 75 °F)	25 ... 36 °C (77 ... 97 °F)	37 ... 49 °C (99 ... 120 °F)
2,301 ... 3,000 m (7,549 ... 9,843 ft)	ASO IJ NDL POS MJ	3 50 W7 2 82	3 48 W7 2 82	3 45 W7 2 82	3 48 W7 1 85	3 48 W7 1 85	

ASL	TEMP	-20 ... -7 °C (-4 ... 19 °F)	-6 ... 5 °C (21 ... 41 °F)	6 ... 15 °C (43 ... 59 °F)	16 ... 24 °C (61 ... 75 °F)	25 ... 36 °C (77 ... 97 °F)	37 ... 49 °C (99 ... 120 °F)
1,501 ... 2,300 m (4,925 ... 7,546 ft)	ASO IJ NDL POS MJ	3 50 W7 2 82	3 50 W7 2 82	3 48 W7 2 82	3 48 W7 2 82	3 48 W7 2 85	3 48 W7 2 88
751 ... 1,500 m (2,464 ... 4,921 ft)	ASO IJ NDL POS MJ	3 52 W7 2 88	3 50 W7 2 85	3 50 W7 2 85	3 50 W7 2 85	3 50 W7 2 88	3 50 W7 2 90
301 ... 750 m (988 ... 2,461 ft)	ASO IJ NDL POS MJ	3 55 W7 2 88	3 52 W7 2 88	3 50 W7 2 88	3 50 W7 2 88	3 50 W7 2 90	3 50 W7 2 92
0 ... 300 m (0 ... 984 ft)	ASO IJ NDL POS MJ	3 55 W7 2 90	3 52 W7 2 90	3 50 W7 2 90	3 50 W7 2 90	3 50 W7 2 92	3 50 W7 2 95

M/FT ASL	Above sea level
TEMP	Temperature
ASO	Open (rotations) idle air adjusting screw
IJ	Idling jet
NDL	Jet needle
POS	Needle position from top
MJ	Main jet

The carburetor tuning depends on the defined ambient and operating conditions.

22.3.2 Carburetor tuning (Option: High seat position)

DeiIOrto PHBG19 BS

ASL	TEMP	-20 ... -7 °C (-4 ... 19 °F)	-6 ... 5 °C (21 ... 41 °F)	6 ... 15 °C (43 ... 59 °F)	16 ... 24 °C (61 ... 75 °F)	25 ... 36 °C (77 ... 97 °F)	37 ... 49 °C (99 ... 120 °F)
2,301 ... 3,000 m (7,549 ... 9,843 ft)	ASO IJ NDL POS MJ	3 50 W7 2 85	3 48 W7 2 85	3 45 W7 2 85	3 48 W7 1 88	3 48 W7 1 88	
1,501 ... 2,300 m (4,925 ... 7,546 ft)	ASO IJ NDL POS MJ	3 50 W7 2 85	3 50 W7 2 85	3 48 W7 2 85	3 48 W7 2 85	3 48 W7 2 88	3 48 W7 2 90
751 ... 1,500 m (2,464 ... 4,921 ft)	ASO IJ NDL POS MJ	3 52 W7 2 90	3 50 W7 2 88	3 50 W7 2 88	3 50 W7 2 88	3 50 W7 2 90	3 50 W7 2 92

ASL	TEMP	-20 ... -7 °C (-4 ... 19 °F)	-6 ... 5 °C (21 ... 41 °F)	6 ... 15 °C (43 ... 59 °F)	16 ... 24 °C (61 ... 75 °F)	25 ... 36 °C (77 ... 97 °F)	37 ... 49 °C (99 ... 120 °F)
301 ... 750 m (988 ... 2,461 ft)	ASO	3	3	3	3	3	3
	IJ	55	52	50	50	50	50
	NDL	W7	W7	W7	W7	W7	W7
	POS	2	2	2	2	2	2
	MJ	90	90	90	90	92	95
0 ... 300 m (0 ... 984 ft)	ASO	3	3	3	3	3	3
	IJ	55	52	50	50	50	50
	NDL	W7	W7	W7	W7	W7	W7
	POS	2	2	2	2	2	2
	MJ	92	92	92	92	95	98

M/FT ASL	Above sea level
TEMP	Temperature
ASO	Open (rotations) idle air adjusting screw
IJ	Idling jet
NDL	Jet needle
POS	Needle position from top
MJ	Main jet

The carburetor tuning depends on the defined ambient and operating conditions.

22.4 Capacities

22.4.1 Gear oil

Gear oil	0.20 l (0.21 qt.)	Gear oil (ATF Dexron 3) (📖 p. 126)
----------	-------------------	------------------------------------

22.4.2 Coolant

Coolant	0.7 l (0.7 qt.)	Coolant (📖 p. 125)
---------	-----------------	--------------------

22.4.3 Fuel

Fuel tank capacity, approx.	2.3 l (2.4 qt.)	Super unleaded (95 octane) mixed with 2-stroke engine oil (1:60) (📖 p. 126)
-----------------------------	-----------------	---

22.5 Chassis

Frame	Central tube frame of chrome molybdenum steel tubing, powder-coated
Fork	WP XACT 35
Shock absorber	WP XACT Mono Shock
Suspension travel	
Front	200.6 mm (7.898 in)
Rear	190.5 mm (7.5 in)
Fork offset	22 mm (0.87 in)
Brake system	
front	Disc brake with 4-piston brake caliper
rear	Disc brake with 2-piston brake caliper

Brake disc diameters	
front	160 mm (6.3 in)
rear	160 mm (6.3 in)
Brake discs - wear limits	
front	2.2 mm (0.087 in)
rear	2.2 mm (0.087 in)
Offroad tire pressure	
front	1.0 bar (15 psi)
rear	1.0 bar (15 psi)
Secondary drive ratio	11:40
Chain	1/2 x 3/16"
Rear sprockets available	38, 39, 40, 41, 42
Steering head angle	66°
Wheelbase	1,023.5 ... 1,035.6 mm (40.295 ... 40.772 in)
Seat height unloaded	634 ... 683 mm (24.96 ... 26.89 in)
Ground clearance unloaded	214.6 ... 222.8 mm (8.449 ... 8.772 in)
Weight without fuel approx.	42.5 kg (93.7 lb.)
Maximum rider weight	45 kg (99 lb.)

22.6 Tires

Validity	Front tire	Rear tire
(50 SX)	60/100 - 12 36J TT MAXXIS MAXXCROSS MX-ST+	2.75 - 10 38J TT MAXXIS MAXXCROSS MX-ST+
(FACTORY EDITION)	60/100 - 12 36J TT Dunlop GEOMAX MX53F	70/100 - 10 41J TT Dunlop GEOMAX MX53

The tires specified represent one of the possible series production tires. For alternative manufacturers, if any, contact an authorized dealer or qualified tire dealership. If local road approval regulations apply, these and the respective technical specifications must be observed. Additional information is available in the Service section under:
KTM.COM

22.7 Fork

Fork article number	A400C102X106000	
Fork	WP XACT 35	
Rebound damping		
Comfort	15 clicks	
Standard	12 clicks	
Sport	10 clicks	
Air pressure	1 bar (15 psi)	
Fork length	685 mm (26.97 in)	
Spring length with preload spacer(s)	337.5 mm (13.287 in)	
Oil capacity external mechanism left	25 ± 5 ml (0.85 ± 0.17 fl. oz.)	Fork oil (SAE 4) (48601166S1) (🔧 p. 125)
Oil capacity, right cartridge	225 ml (7.61 fl. oz.)	Fork oil (SAE 4) (48601166S1) (🔧 p. 125)

Grease capacity, left cartridge	6 g (0.21 oz)	Special grease (00062010053) (🔧 p. 128)
---------------------------------	---------------	--

22.8 Shock absorber

Shock absorber article number	A400C402X113000	
Shock absorber	WP XACT Mono Shock	
Low-speed compression damping		
Comfort	18 clicks	
Standard	15 clicks	
Sport	12 clicks	
High-speed compression damping		
Comfort	2.5 turns	
Standard	2 turns	
Sport	1.5 turns	
Rebound damping		
Comfort	18 clicks	
Standard	15 clicks	
Sport	12 clicks	
Spring preload	5 mm (0.2 in)	
Spring rate		
Weight of rider: 15 ... 25 kg (33 ... 55 lb.)	25 N/mm (143 lb/in)	
Weight of rider (standard): 25 ... 35 kg (55 ... 77 lb.)	30 N/mm (171 lb/in)	
Weight of rider: 35 ... 45 kg (77 ... 99 lb.)	35 N/mm (200 lb/in)	
Spring length	130 mm (5.12 in)	
Gas pressure	10 bar (145 psi)	
Static sag	30 mm (1.18 in)	
Rider sag	80 mm (3.15 in)	
Fitted length	275 mm (10.83 in)	
Shock absorber oil	Shock absorber fluid (SAE 2.5) (50180751S1) (🔧 p. 126)	

22.9 Chassis tightening torques

Hose clip, carburetor	-	2.8 Nm (2.07 lbf ft)
Remaining EJOT PT screws	EJOT PT K60x20	2 Nm (1.5 lbf ft)
Screw, brake line holder	EJOT PT K60x20-Z	2 Nm (1.5 lbf ft)
Throttle cable wire to carburetor	-	1 Nm (0.7 lbf ft)
Stop button screw	M3	0.4 Nm (0.3 lbf ft)
Screw, seat thrust bearing quick release	EJOT PT 35x16 M3.5	0.75 Nm (0.553 lbf ft)
Spoke nipple	M3.5	3 Nm (2.2 lbf ft)
Screw, fixed grip	M4	5 Nm (3.7 lbf ft)
		Loctite®243™
Remaining nuts, chassis	M5	5 Nm (3.7 lbf ft)
Remaining screws, chassis	M5	5 Nm (3.7 lbf ft)

Screw, brake linings	M5	5 Nm (3.7 lbf ft)	
Screws on main silencer (FACTORY EDITION)	M5	9 Nm (6.6 lbf ft)	Loctite®243™
Brake cylinder screw on the rear brake system	M6	10 Nm (7.4 lbf ft)	Loctite®243™
Nut, push rod ball joint on the brake cylinder of the rear brake system	M6	10 Nm (7.4 lbf ft)	
Nut, push rod, foot brake lever	M6	6 Nm (4.4 lbf ft)	
Remaining nuts, chassis	M6	10 Nm (7.4 lbf ft)	
Remaining screws, chassis	M6	10 Nm (7.4 lbf ft)	
Screw, brake assembly	M6	5 Nm (3.7 lbf ft)	
Screw, engine sprocket cover	M6	8 Nm (5.9 lbf ft)	
Screw, fender	M6	6 Nm (4.4 lbf ft)	
Screw, fork stub	M6	10 Nm (7.4 lbf ft)	
Screw, front brake disc	M6	14 Nm (10.3 lbf ft)	Loctite®243™
Screw, main silencer silent block	M6	6 Nm (4.4 lbf ft)	
Screw, radiator shield on radiator	M6	5 Nm (3.7 lbf ft)	
Screw, rear brake disc	M6	14 Nm (10.3 lbf ft)	Loctite®243™
Screw, rear mounting	M6	6 Nm (4.4 lbf ft)	
Screw, start number plate	M6	4 Nm (3 lbf ft)	
Screw, throttle grip	M6	5 Nm (3.7 lbf ft)	
Bushing, foot brake lever stop	M8	20 Nm (14.8 lbf ft)	
Engine bracket screw	M8	25 Nm (18.4 lbf ft)	Loctite®243™
Nut, rim lock	M8	10 Nm (7.4 lbf ft)	
Rear brake caliper screw	M8	20 Nm (14.8 lbf ft)	Loctite®243™
Remaining nuts, chassis	M8	25 Nm (18.4 lbf ft)	
Remaining screws, chassis	M8	25 Nm (18.4 lbf ft)	
Screw, bottom triple clamp	M8	15 Nm (11.1 lbf ft)	
Screw, chain sliding piece	M8	15 Nm (11.1 lbf ft)	
Screw, front brake caliper	M8x35	20 Nm (14.8 lbf ft)	Loctite®243™
Screw, handlebar clamp	M8	20 Nm (14.8 lbf ft)	
Screw, rear sprocket	M8	25 Nm (18.4 lbf ft)	Loctite®243™
Screw, steering stem	M8	20 Nm (14.8 lbf ft)	
Screw, tail assembly	M8	30 Nm (22.1 lbf ft)	Loctite®243™
Screw, top triple clamp	M8	20 Nm (14.8 lbf ft)	
Bushing, foot brake lever	M10	45 Nm (33.2 lbf ft)	
Remaining nuts, chassis	M10	45 Nm (33.2 lbf ft)	
Remaining screws, chassis	M10	45 Nm (33.2 lbf ft)	
Screw, bottom shock absorber	M10	45 Nm (33.2 lbf ft)	Loctite®243™

22 TECHNICAL SPECIFICATIONS

Screw, front wheel spindle	M10	40 Nm (29.5 lbf ft) Loctite®243™
Screw, handlebar support	M10	40 Nm (29.5 lbf ft) Loctite®243™
Screw, top shock absorber	M10	45 Nm (33.2 lbf ft) Loctite®243™
Rear wheel spindle nut	M12x1	70 Nm (51.6 lbf ft)
Swingarm pivot bushing	M12x1	40 Nm (29.5 lbf ft)
Nut, steering head	M20x1.5	10 Nm (7.4 lbf ft)

Brake fluid DOT 4 / DOT 5.1**Standard/classification**

- DOT

Guideline

- Use only brake fluid that complies with the specified standard (see specifications on the container) and that exhibits the corresponding properties.

Recommended supplier**Castrol**

- REACT PERFORMANCE DOT 4

MOTOREX®

- Brake Fluid DOT 5.1

Coolant**Guideline**

- Only use high-grade, silicate-free coolant with corrosion inhibitor additive for aluminum motors. Low grade and unsuitable antifreeze causes corrosion, deposits and frothing.
- Do not use pure water as only coolant is able to meet the requirements needed in terms of corrosion protection and lubrication properties.
- Only use coolant that complies with the requirements stated (see specifications on the container) and that has the relevant properties.

Antifreeze protection to at least	-25 °C (-13 °F)
-----------------------------------	-----------------

The mixture ratio must be adjusted to the necessary antifreeze protection. Use distilled water if the coolant needs to be diluted.

The use of premixed coolant is recommended.

Observe the coolant manufacturer specifications for antifreeze protection, dilution and miscibility (compatibility) with other coolants.

Recommended supplier**MOTOREX®**

- COOLANT M3.0

Engine oil, 2-stroke**Standard/classification**

- JASO FD (📖 p. 129)

Guideline

- Only use high-grade 2-stroke engine oil from a reputable brand.

fully synthetic

Recommended supplier**MOTOREX®**

- Cross Power 2T

Fork oil (SAE 4) (48601166S1)**Standard/classification**

- SAE (📖 p. 129) (SAE 4)

Guideline

- Use only oils that comply with the specified standards (see specifications on the container) and that exhibit the corresponding properties.

Gear oil (ATF Dexron 3)

Standard/classification

- Dexron III (ATF Dexron 3)

Guideline

- Use only ATF gear oils that comply with the specified standards (see specifications on the container) and that possess the necessary properties.

Recommended supplier

MOTOREX®

- ATF Dexron 3

Shock absorber fluid (SAE 2.5) (50180751S1)

Standard/classification

- SAE (📖 p. 129) (SAE 2.5)

Guideline

- Use only oils that comply with the specified standards (see specifications on the container) and that exhibit the corresponding properties.

Super unleaded (ROZ 95)

Standard/classification

- DIN EN 228 (ROZ 95)

Guideline

- Only use super unleaded fuel that matches or is equivalent to the specified standard.
- Fuel with an ethanol content of up to 10% (E10 fuel) is safe to use.



Info

Do **not** use fuel containing methanol (e.g., M15, M85, M100) or more than 10% ethanol (e.g., E15, E25, E85, E100).

Super unleaded (95 octane) mixed with 2-stroke engine oil (1:60)

Standard/classification

- DIN EN 228
- JASO FD (📖 p. 129) (1:60)

Mixture ratio

1:60	Engine oil, 2-stroke (📖 p. 125) Super unleaded (ROZ 95) (📖 p. 126)
------	---

Recommended supplier

MOTOREX®

- Cross Power 2T

Air filter cleaner

Recommended supplier

MOTOREX®

- Racing Bio Dirt Remover

Chain cleaner

Recommended supplier

MOTOREX®

- Chain Clean

Fuel additive

Recommended supplier

MOTOREX®

- Fuel Stabilizer

High viscosity grease

Recommended supplier

SKF®

- LGHB 2

Long-life grease

Recommended supplier

MOTOREX®

- Bike Grease 2000

Motorcycle cleaner

Recommended supplier

MOTOREX®

- Moto Clean

Off-road chain spray

Recommended supplier

MOTOREX®

- Chainlube Offroad

Oil for foam air filter

Recommended supplier

MOTOREX®

- Racing Bio Liquid Power

Preserving materials for paints, metal and rubber

Recommended supplier

MOTOREX®

- Moto Protect

Special cleaner for glossy and matte paint finishes, metal and plastic surfaces

Recommended supplier

MOTOREX®

- Quick Cleaner

Special grease (00062010053)

Recommended supplier

Klüber Lubrication®

- Klüberfood NH1 34-401

Universal oil spray

Recommended supplier

MOTOREX®

- Joker 440 Synthetic

JASO FD

JASO FD is a classification for a 2-stroke engine oil that was specifically developed for the extreme demands of racing. Thanks to first-rate synthetic esters and specially designed additives, superb combustion is achieved even under extreme operating conditions.

SAE

The SAE viscosity classes were defined by the Society of Automotive Engineers and are used for classifying oils according to their viscosity. The viscosity describes only one property of oil and says nothing about quality.

26 LIST OF ABBREVIATIONS

Art. no.	Article number
ca.	circa
cf.	compare
e.g.	for example
etc.	et cetera
i.a.	inter alia
no.	number
poss.	possibly

PARENTS, YOUNGSTERS & OFF-HIGHWAY MOTORCYCLES



THE MSF
DIRTBIKE
SCHOOL™

The information contained in this publication is offered for the benefit of those who have an interest in riding off-highway motorcycles. The information has been compiled from publications, interviews and observations of individuals and organizations familiar with the use of off-highway motorcycles. Because there are many differences in product design, riding terrain and riding styles, there may be organizations and individuals who hold differing opinions. Consult your local motorcycle dealers or experienced off-highway motorcycle riders about appropriate riding locations in your area. Although the Motorcycle Safety Foundation will continue to publish responsible viewpoints on this subject, it must disclaim specific or general liability for the views expressed herein.

The Motorcycle Safety Foundation® (MSF) is a national not-for-profit organization promoting the safety of motorcyclists with programs in rider training, operator licensing and public information. The MSF is sponsored by BMW, BRP, Ducati, Harley-Davidson, Honda, Kawasaki, KTM, Piaggio, Polaris Motorcycles, Suzuki, Triumph and Yamaha.

Motorcycle Safety Foundation
2 Jenner, Suite 150
Irvine, CA 92618
949.727.3227
msf-usa.org

Copyright 2015
Printed: March 2015

Parents...Be Cautious

Riding Off-Highway Motorcycles (OHMs) can be an enjoyable form of outdoor recreation when done properly. With preparation, practice, and parental supervision your youngster can safely develop and expand his or her riding skills. Remember, off-highway motorcycles are not toys.

This manual is designed to assist you in the important task of teaching your youngster the safe and responsible use of an off-highway motorcycle. We urge you to read this booklet thoroughly. Also read other information provided with the motorcycle. The owner's manual contains important warnings and features of the motorcycle.

Deciding if your youngster is ready to ride an off-highway motorcycle is an important decision. The MSF strongly urges you to carefully determine your youngster's readiness to ride. There is a Readiness Checklist in Part 4 of this booklet. **Do not permit youngsters to ride an off-highway motorcycle if you doubt that they will operate the motorcycle safely.**

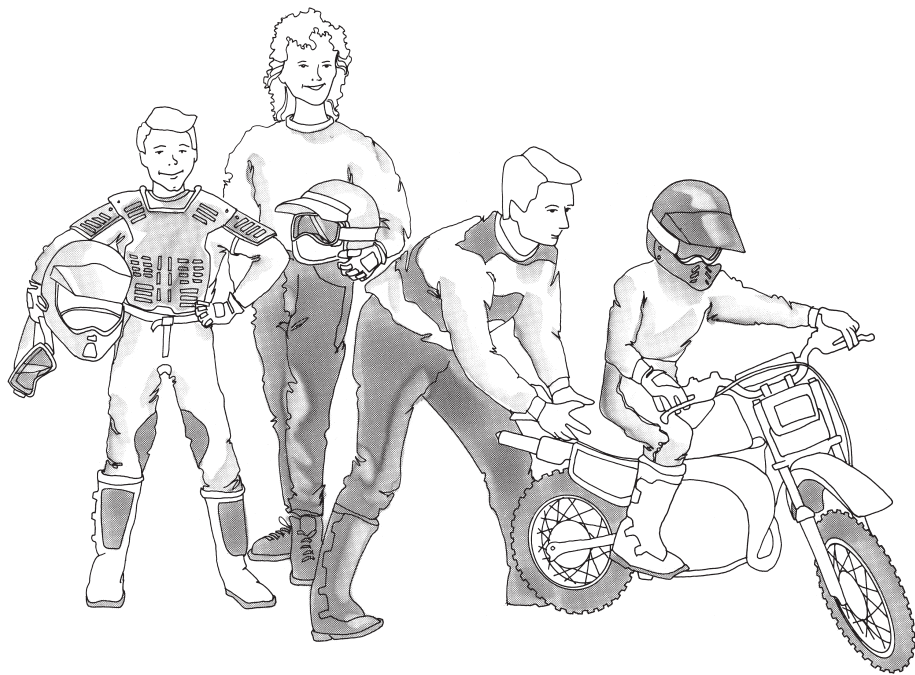

CONTENTS

INTRODUCTION

- Purpose of the Booklet 4
- Important Note to Parents 4
- Other Sources of Information 5

PART 1: Determining Your Youngster's Readiness to Ride an Off-Highway Motorcycle

- Readiness Guidelines 6
- Steps for Safe and
Responsible OHM Riding 10

PART 2: Pre-Operating Procedures and Practice

- Protective Gear and Clothing 11
- Mounting/Dismounting 12
- Mastering the Controls 13
- Learning Activities 16

PART 3: Operating Procedures and Practice

- Learning Area/Riding Area 20
- Getting Used to the Vehicle in
Motion 22
- Let's Start Riding 25

PART 4: Readiness Checklist

- Visual Perception/Motor/
Development 29
- Physical Development 32
- Social/Emotional Development 34
- Reasoning and Decision-Making
Ability 36

FINAL NOTE: To Parents 38

GLOSSARY 39

ANSWERS 41

INTRODUCTION

Purpose of the Booklet

Parents, *Youngsters and Off-Highway Motorcycles* is designed to assist you in determining if your youngster is ready to ride off-highway motorcycles (OHMs). It also provides you and your youngster with important safety information and tips on learning to ride. This booklet is divided into four parts: Part 1: Determining Your Youngster's Readiness to Ride an Off-highway Motorcycle; Part 2: Pre-operating Procedures; Part 3: Operating Procedures; Part 4: Readiness Checklist. There is information about protective gear, mounting, control operation and starting the engine. Operating procedures include starting, shifting, stopping and turning.

Important Note To Parents

Once your youngster is ready to learn to ride, YOU must be familiar with the motorcycle. You will be serving as teacher, coach, and safety supervisor for your youngster. You must know the controls, handling characteristics, maintenance requirements, and proper riding techniques. Read and understand the owner's manual and the labels provided with the vehicle. Review all instructions, requirements, and warnings with your youngster. Find out about state or local off-highway motorcycle requirements.

Other Sources Of Information

In addition to the information provided in *Parents, Youngsters and Off-Highway Motorcycles*, there are other sources for obtaining safety information. The owner's manual provides specific maintenance and operating procedures for your motorcycle. It also includes warnings and cautions, as well as operating tips. Motorcycle dealers may have other literature and safety information. Another booklet, *Tips and Practice Guide for the Off-Highway Motorcyclist*, gives detailed riding procedures.

The MSF *DirtBike School*SM offers training on how to ride off-highway motorcycles. The course is available to youth as young as six years of age, as well as to adults. Call toll-free 877.288.7093 to enroll or for more information. To find out more on the internet, visit dirtbikeschool.com.

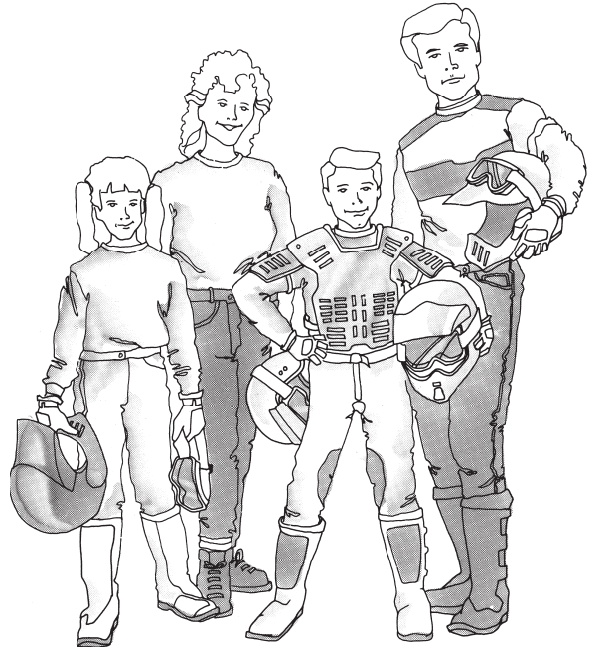

PART 1

DETERMINING YOUR YOUNGSTER'S READINESS TO RIDE AN OFF-HIGHWAY MOTORCYCLE

The first important decision you will have to make concerning your youngster and off-highway motorcycles (OHMs) is whether your youngster is ready to ride. There are several factors that you must consider carefully.

There is no certain way to predict that your child is able to ride an OHM safely. However, the following information is a guide to help you determine your youngster's readiness to ride. Only parents can decide if their youngster has the qualities necessary to operate an off-highway motorcycle safely.

Readiness Guidelines

PHYSICAL DEVELOPMENT

Physical size and ability are important considerations. For example, a youngster must be big enough to hold the motorcycle up, get on, and comfortably sit on the seat with both feet touching the ground.

Also make sure your youngster can comfortably reach and work all the controls. For example, can they turn the handlebars all the way to the right and left? Can they easily use their feet to work the brake pedal and gearshift lever? Can they operate the throttle and brake levers while they hold onto the handgrips? If not, the youngster is not physically ready to ride this OHM. Refer to the owner's manual to check for possible adjustments in the position of some of the controls.

PART 1

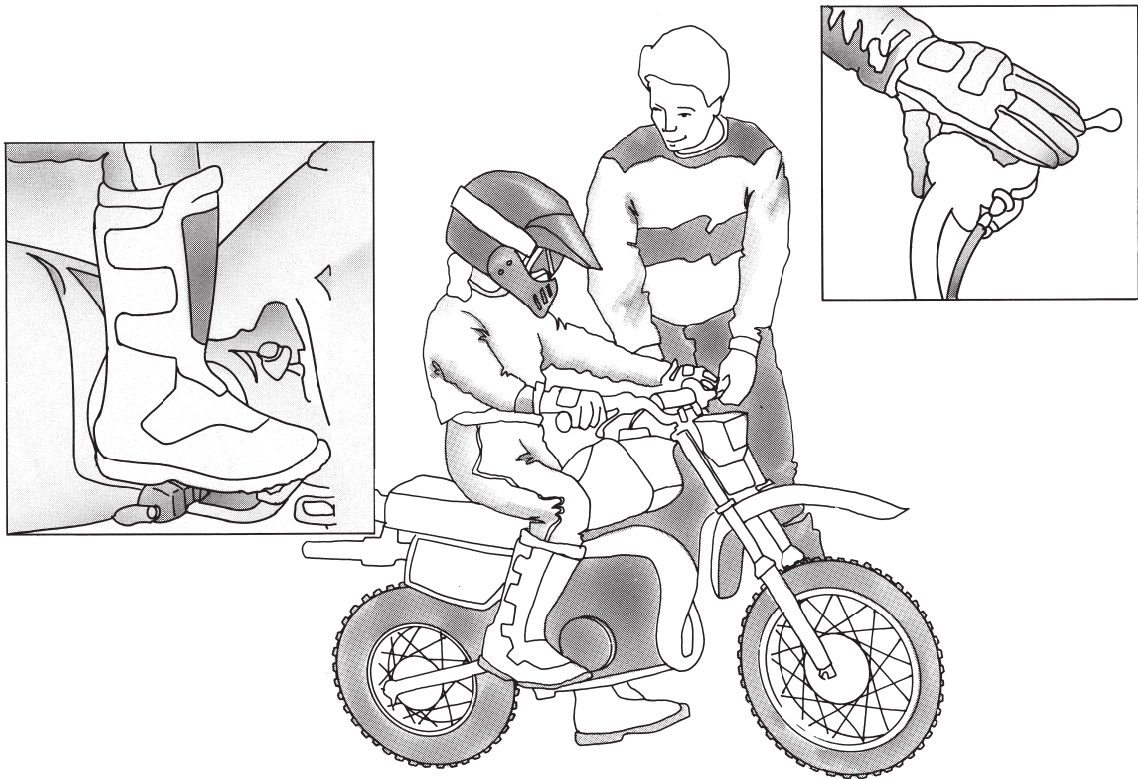

PART 1

Additional signs of physical readiness can be observed in your youngster's other play activities. In general, a youngster should be well-coordinated, having good balance and agility. This coordination can be demonstrated by the abilities to jump rope, skate, skateboard, ride a bicycle, etc. If a youngster cannot perform well in these types of activities, more physical development is needed.

SOCIAL/EMOTIONAL DEVELOPMENT

How a youngster behaves in a social setting can be a sign of social/emotional development. A youngster needs to know about and understand rules. Certain rules are necessary for the safe operation of any vehicle. Youngsters must be willing to follow rules. A good sign is a youngster who obeys rules set by parents. A youngster who does not follow rules is not ready for an OHM.

One indicator that a youngster is ready to ride an

OHM is when they demonstrate a safety-conscious attitude and are aware of possible injury from reckless OHM operation. If the youngster has a habit of recklessness or is often involved in accidents while using bicycles or skateboards, the youngster is not ready to ride an OHM.

REASONING AND DECISION-MAKING ABILITY

Youngsters should have some knowledge about what may happen if something is done wrong. They must understand that unsafe actions can result in injury. An example of this is knowing the need to look in both directions before crossing a street when walking to school. The ability to make good decisions relates to a youngster's ability to reason. When presented with a problem, the youngster should be able to come up with a sensible answer. Ask your youngster to tell you what causes accidents and injuries. Your youngster needs to be able to tell

what causes accidents and how to avoid them. In general, a youngster should understand that he or she can get hurt as a result of making poor choices.

VISUAL PERCEPTIONS AND MOTOR DEVELOPMENT

This area involves how well a youngster sees and how vision is used with other physical movements. In other words, can a youngster see and react with the proper hand, foot, or body movement?

Several types of visual characteristics are important. The ability to see to the sides while looking straight ahead is called peripheral or side vision. You can determine a youngster's side vision by having him or her look straight ahead while you move objects to the side. The youngster should be able to see objects ninety degrees to the side while looking straight ahead. Rider awareness and safety improves with good side vision.

Being able to judge distance is another visual skill helpful when operating an OHM. Is your youngster able to tell how far one object is from another, or which of two objects is closer? OHM riding requires a person to judge distance and react properly.

Being good at playing video games, hitting a baseball, etc., is a good sign that a youngster's eye and hand movements are fairly well coordinated.

In summary, you must consider many things before you decide to put your youngster on an OHM. There is no exact formula to use in making this decision. The Readiness Checklist, Part 4, can assist you with some points to evaluate. If you are not able to check-off most of the statements, your youngster is probably not ready to ride an OHM.

PART 1

Steps For Safe And Responsible OHM Riding

Once you determine that OHM use is proper for your youngster, it is time to prepare yourself as a good OHM teacher and supervisor.

STEP ONE: Educate Yourself about OHM Safety and Proper Riding Techniques

You must learn as much as possible about off-highway motorcycles in general, and especially your youngster's motorcycle. You must be qualified to instruct and supervise your youngster. This means that you will need to understand the features of the motorcycle and proper riding techniques. The best source of information is the owner's manual supplied with the motorcycle. Read the owner's manual before you begin to instruct your youngster about OHM safety. Pay particular attention to the warning labels and stickers on the motorcycle.

STEP TWO: Teach Your Youngster Safe and Proper Riding Techniques

Teaching your youngster off-highway motorcycling is a step-by-step process. It begins with safety rules and moves to actual riding techniques. Since youngsters learn at different rates, it will be up to you to set the pace of your youngster's progress. At some point you may decide that he or she is not ready to ride an OHM.

STEP THREE: Avoid Unsafe Situations Through Close Supervision

ALWAYS closely supervise your youngster's riding. This is true even if your youngster has learned and mastered the rules and skills of safe OHM riding. Youngsters can get tired easily and become careless. They do not always see everything that is important around them. Your close supervision and good judgment are important.

Protective Gear And Clothing

The nature of off-highway riding demands that your youngster wear proper protective gear. Motorcycle riders should ALWAYS wear a helmet, eye protection, gloves, long pants, a long-sleeved shirt or jacket, and over-the-ankle boots. Anything less is not adequate protection. NEVER let anyone ride an off-highway motorcycle without a Department of Transportation (DOT) compliant motorcycle helmet. Be sure the fit is correct. It should be snug but not tight. It must be properly fastened.

Protective gear is necessary in any weather, even when the temperature is warm. In cooler weather you should dress your youngster with additional layers of clothing. Some riders choose to wear a kidney belt and chest or back protector for additional protection. On the right is a drawing of well-equipped riders. Show this drawing to your youngster and point out what is important.

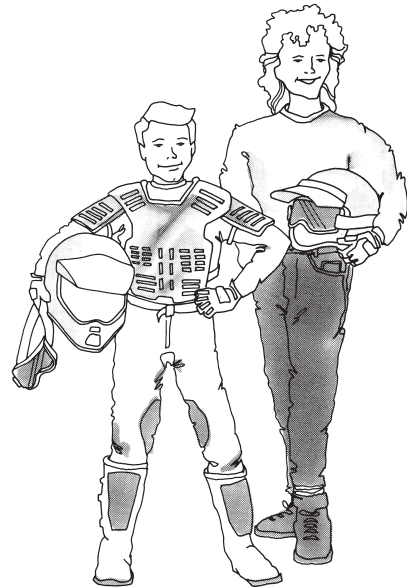

PART 2

Mounting/Dismounting

Have your youngster wear safety gear whenever getting on a motorcycle. This action will stress the importance of safety gear and help develop safe riding habits.

Mounting is typically from the left side. To mount from the left, point the handlebars straight. While squeezing the front brake lever, swing the right leg over the seat and place the right foot on the ground. Both feet should be in contact with the ground while sitting on the motorcycle. Dismounting reverses the procedure: the kickstand is placed fully down. With the left foot on the ground, the handlebars straight and the front brake lever squeezed, the right leg is swung over the seat and the foot touches the ground.

Correct riding posture helps your youngster operate the controls. Proper straight line riding posture includes:

- Head and eyes up, looking well ahead.
- Shoulders relaxed, back straight.

- Elbows bent, slightly out and away from the body.
- Hands on the handlebars.
- Knees in toward the tank.
- Feet on the footpegs, toes pointing straight ahead.

The hand and foot controls are important to riding safely. While riding, both hands should be kept on the handlebars and both feet on the footpegs of the motorcycle. Removing a hand or foot can reduce the ability to control the motorcycle.

An off-highway motorcycle rider will need to shift body weight in certain situations. This is especially true in maneuvers such as turning, negotiating hills, and riding on bumpy terrain. Your youngster should be able to operate the controls during these maneuvers. Now is a good time to make sure your youngster can reach the controls from different body positions. Have the youngster remount. Turn the handlebars full left

and full right. See that this can be done easily. Next have the youngster slide up and back on the seat. Mention that body movement is important. Body movement and shifting weight help to control the motorcycle.

(Go through these control exercises with the motorcycle's engine OFF.)

Mastering The Controls

Show your youngster how to use each control as you describe its action. Refer to the owner's manual to learn control location and function before instructing your youngster. Test yourself by operating the controls. Have your youngster dress in the proper protective gear and sit on the machine as you point out each control. It is important to have your youngster wear all the protective gear whenever sitting on an off-highway motorcycle.

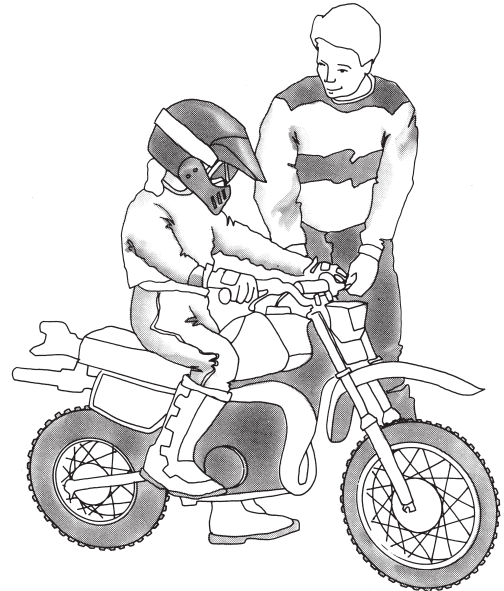

PART 2

BRAKES

Most small off-highway motorcycles have a hand lever on the right handlebar which operates the front brake. Most also have a foot pedal on the right side to operate the rear brake. Refer to the owner's manual for correct brake location and operation.

Explain and demonstrate proper braking procedure. Be sure your youngster can apply the brake(s) properly while seated and without looking down. Smooth operation should be encouraged.

THROTTLE CONTROL

Explain to your youngster that twisting the throttle control back will make the motorcycle go faster. Closing the throttle control slows the motorcycle.

Youngsters need practice using the throttle control smoothly. They tend to use it like an on/off switch. With the engine off, have your youngster

move the throttle to various positions. Practice turning the handlebars and using the throttle at the same time.

ENGINE STOP SWITCH

Explain to your youngster how to use the engine stop switch to turn off the engine. With the engine off, show how the stop switch works. Later, your youngster can practice using the stop switch when the engine is actually running.

CLUTCH/SHIFT LEVER

Some small OHMs do not have a clutch lever; some don't have a shift lever either. This section applies only to motorcycles with a shift lever. Those that do have a shift lever may have different shift patterns. Refer to your owner's manual for proper shifting instructions. It is important to learn how the shift lever works.

Explain that it is possible to shift the motorcycle with the shift lever in order to ride at different speeds.

Have your youngster practice shifting with the engine off. The shift lever, clutch lever (if equipped), and throttle control work together to move the motorcycle. When shifting to first gear from neutral the throttle is closed, the clutch lever is squeezed, and the front brake is applied before moving the shift lever into first gear. When starting out, the front brake is released. The throttle is gradually opened while the clutch is slowly released. If the clutch is released too quickly, or too much throttle is applied, the motorcycle may lunge forward causing loss of control. With the engine off, have your youngster practice upshifts, downshifts, and locating neutral.

SPEED LIMITERS

(supervisor control feature)

Some models come equipped with a removable exhaust restrictor, or another feature which reduces maximum speed. Refer to your owner's manual or talk to your dealer about this.

PART 2

NAME THE MOTORCYCLE PARTS (Typical)

Have your youngster write the number of the motorcycle part or control on the correct line for the diagrams shown. (*Answer Guide on Page 42*)

1. Clutch lever
2. Hand brake lever
3. Foot brake lever or pedal
4. Throttle
5. Choke or enriching device
6. Engine stop switch
7. Gas cap/tank vent
8. Starter (kick)
9. Electric starter (if equipped)

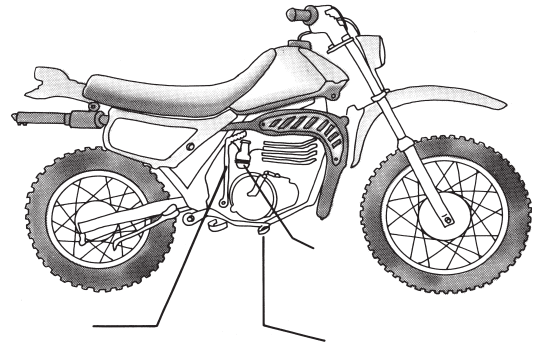
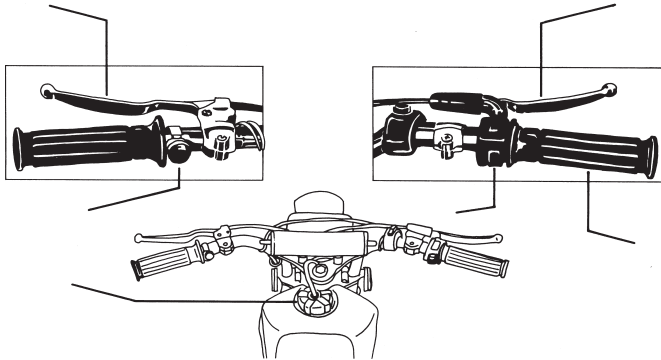

PART 2

LOCATING THE CONTROLS GAME

Now that you have shown your youngster the controls, it is your youngster's turn to show you. The engine remains OFF for this exercise and your youngster will be on the motorcycle. The youngster should be wearing the proper protective gear to develop this safety habit.

1. Have your youngster show you the location of the following:

- Brakes (lever and pedal)
- Throttle Control
- Engine Stop Switch
- Shift Lever (if equipped)
- Clutch (if equipped)

2. Have your youngster show you how the controls work. Be sure he or she understands the proper operation of each control. Skilled use of these controls should develop with practice. Under actual riding conditions the rider will have to watch ahead while operating the controls. Your youngster should be able to find the controls quickly without looking for them.
3. With your youngster looking ahead (pick out a point to look at), have him or her operate the controls. Repeat often while changing the order.
4. Ask your youngster to operate the controls as if actually riding. Look for smooth and precise operation.

PRE-RIDE CHECK

Before you continue:

1. Have you determined your youngster's readiness to ride an OHM? Do not let your youngster ride if you have any doubt. (Refer to the Readiness Checklist, Part 4)
2. Have you read the owner's manual and reviewed it with your youngster?
3. Does your youngster fit the motorcycle properly?
4. Have you inspected the vehicle and maintained it according to the owner's manual?
5. Is your youngster wearing the proper protective gear? Is the mounting procedure correct?
6. Has your youngster learned to locate the motorcycle controls without looking at them? Does he or she know how to operate them smoothly?
7. Does your youngster understand that he or she must always ride off-road?
8. Have you stressed to your youngster to keep his or her feet on the footpegs while riding?

If you have completely covered all these areas, you are ready to go on to Part 3.

PART 3

OPERATING PROCEDURES AND PRACTICE

Carefully observe your youngster's first use of the motorcycle. Observe his or her readiness to ride. Only permit your youngster to continue to ride if they have the size, strength, and attitude needed to ride safely.

Show your youngster the engine, exhaust pipe, and muffler. Tell him or her not to touch these parts because they are hot while the engine is running. Explain that they will remain hot after the engine is stopped. Also explain that hands and feet must be kept away from moving parts of the motorcycle.

Your youngster's safety depends in part on the mechanical condition of the motorcycle. Be sure to inspect it thoroughly before each use. Starting and refueling of the vehicle should be done by responsible adults only. Follow a regular maintenance program. See the owner's manual for inspection details.

Even after young riders have learned the basic riding skills, direct supervision by an experienced adult is necessary AT ALL TIMES. Make sure

that all off-highway motorcycle users under your supervision get proper riding instructions. Stress that an OHM is not a toy. Follow safety precautions strictly to provide a "safety first" approach to off-highway motorcycle riding. Teaching your youngster how to ride an OHM safely will increase the enjoyment of off-highway motorcycle riding.

Learning Area/Riding Area

The best place for learning is a level area 100' x 200' that is free from obstacles such as rocks, stumps, or holes. The learning area may have a loose or hard dirt surface. A grassy surface is also acceptable. It should not have two different surfaces. **Under no circumstances should the surface be concrete or asphalt.** Be sure there is room enough to maneuver, and that no other riders are close.

PART 3

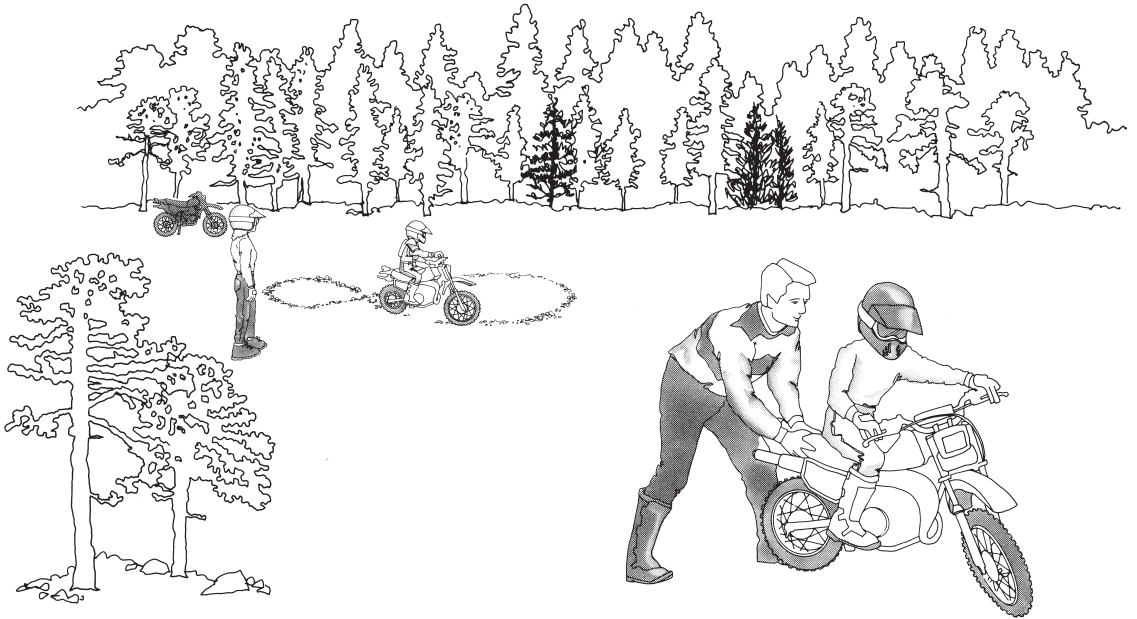

PART 3

Getting Used To The Vehicle In Motion

GETTING THE FEEL OF THE BRAKES

Be sure your youngster is wearing all of the proper protective gear. With the engine still OFF, have your youngster mount the motorcycle. If you physically can, push the motorcycle slowly. Have your youngster brake to feel how much pressure is needed for a smooth stop. If your youngster's motorcycle has more than one brake, both should be applied with even pressure. Practice this several times until you are sure this skill is developed. Remind your youngster to keep his or her head up and look forward.

GETTING THE FEEL OF THE THROTTLE

With the engine OFF, have your youngster practice smooth throttle control. Your youngster will learn how much throttle it takes to start moving in

a later exercise. Explain that opening the throttle will increase speed and that closing the throttle will decrease speed. Releasing the throttle and applying the brakes will slow the motorcycle. Ask your youngster to tell you how throttle control and braking affect the motorcycle's speed.

GETTING THE FEEL OF THE CLUTCH

(if equipped)

With the engine OFF, have your youngster practice smooth clutch control. Have your youngster shift the motorcycle into first gear. While you push the motorcycle have the youngster slowly release the clutch lever. The point which the motorcycle stops moving indicates the clutch engagement point or "friction zone." The "friction zone" is the point at which engine power begins to be transmitted to the rear wheel. Explain that this is the point the motorcycle will start moving when the engine is running. Smooth operation will prevent stalling and

allow smooth shifting. Remind the youngster that the throttle should be closed when shifting gears. Practice this exercise several times until the skill is developed.

GETTING THE FEEL OF TURNING

With the vehicle stopped and the engine OFF, have your youngster practice the proper turning technique:

1. For a right turn, look to the right and lean the motorcycle to the right.
2. For a left turn, look to the left and lean the motorcycle to the left.

Repeat this exercise with the kickstand up as you push the motorcycle. Make sure he or she can turn the vehicle in both directions using this technique while you maintain balance of the motorcycle.

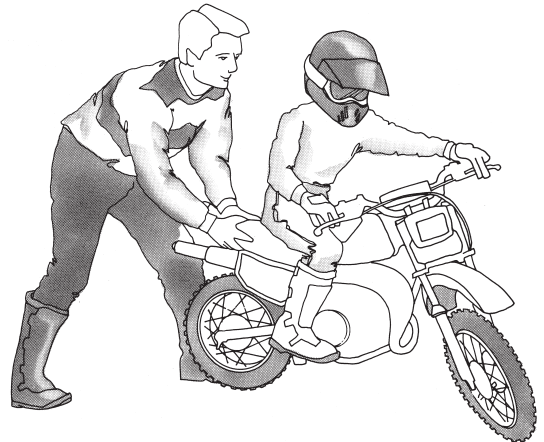

PART 3

BEING PREPARED FOR RIDING PRACTICE

Be sure to observe all the safety precautions covered in the Introduction and Parts 1 and 2. Double check that the riding area is free from hazards. Your youngster should wear all the proper protective gear, and the speed limiter (if equipped) should be installed and working correctly.

STARTING THE MOTORCYCLE

Always start the motorcycle for your youngster. To remember the proper starting technique use "FINE-C."

Double check for neutral. Start the engine. Have your youngster carefully mount. Let your youngster operate the engine stop switch and shut off the motor. Re-start the engine and repeat. Allow the engine to warm up until it runs smoothly with the choke off.

F	FUEL VALVE	Put to "on" position.
I	IGNITION	Ignition on.
N	NEUTRAL	Motorcycle in neutral (the motorcycle rolls with the clutch lever released).
E	ENGINE	Stop switch in run/on start position.
C	CHOKE	On (for cold engine only).

Let's Start Riding

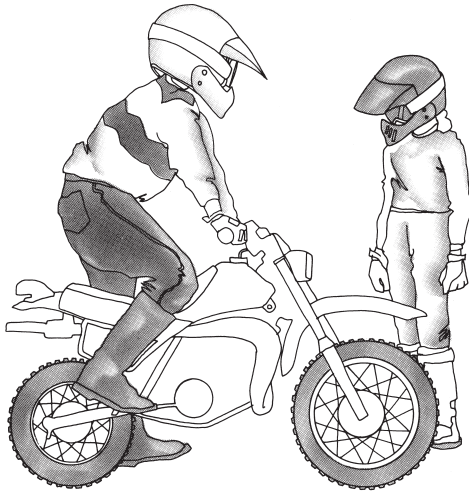

Start the motorcycle for your youngster

Walk next to the motorcycle when your youngster first starts riding. You can also let the beginner ride back and forth between you and another adult. Help your youngster with the turns as he or she practices throttle control and braking.

STARTING OUT AND STOPPING

Before your youngster moves the motorcycle under power, take a few moments to practice smooth clutch control. After shifting to first gear, have your youngster rock the motorcycle a few inches back and forth by moving the clutch in and out of the "friction zone." The clutch is not fully released while doing this. It is important that clutch operation is smooth before riding in the practice area.

The next practice session is straight-line starts and stops. Keep the riding under control.

PART 3

However, riding too slowly will make balance more difficult. Both brakes should be used together for smooth stops. The left foot should be placed on the ground first, keeping the right foot on the rear brake.

Be sure your youngster develops a good feel for the use of the throttle and controls. After the youngster has mastered starting and stopping at slower speeds, increase speeds by shifting.

TURNING

Remind your youngster of the two steps for turning:

1. For a right turn, look to the right and lean the motorcycle to the right.
2. For a left turn, look to the left and lean the motorcycle to the left.

Have your youngster practice turning in both directions at slow speeds. Allow enough room to make a wide turn. After your youngster is skilled in making wide turns, try tighter turns.

Keep speed slow.

Your youngster should master these skills at low speeds before going faster. Next, practice some figure eights. This will help your youngster make left and right turns. Make sure your youngster keeps both feet on the footpegs and looks ahead in the turns.

Once these skills are mastered, refer to the [Tips & Practice Guide for the Off-Highway Motorcyclist](#), for additional skills used in off-highway riding.

PART 3

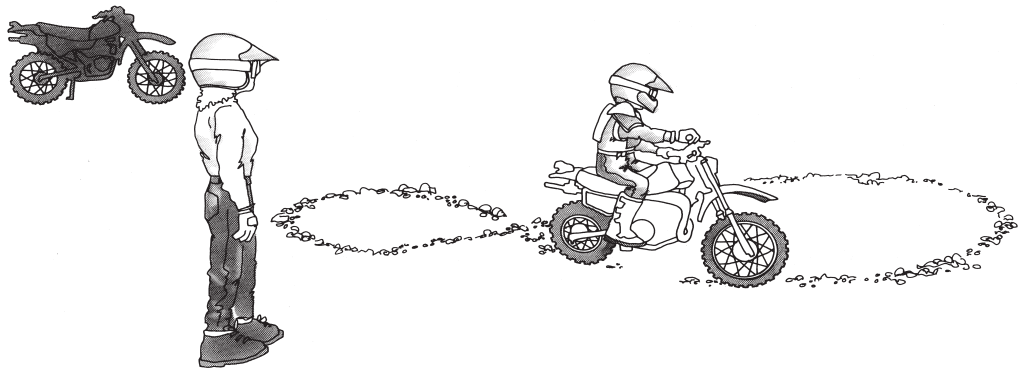

PART 4

READINESS CHECKLIST

This Readiness Checklist is provided to help you determine your youngster's readiness to learn to safely operate and control an OHM. There is a significant amount of judgment needed in determining a youngster's readiness to ride an OHM. The ultimate decision is the responsibility of the parent, guardian, or supervising adult. It is important that parents make informed decisions about whether or not their youngster becomes involved in off-highway motorcycle activity.

There are four developmental areas considered in the Readiness Checklist. These include: visual perception/motor development, physical development, social/emotional development, and reasoning and decision-making ability. Several questions are listed to help you determine if your youngster possesses the skills and capabilities to safely learn to operate an OHM.

The best way to utilize the Readiness Checklist is to read the particular ability, consider the answers to the questions for that ability, and check those abilities that you determine are present in your youngster. There are no suggestions as to how many abilities or the degree of ability that your youngster should possess. This Readiness Checklist may help you consider the appropriateness of OHM operation for your child. The ultimate decision for your youngster's involvement with off-highway motorcycles belongs to you, the parent.

VISUAL PERCEPTION/MOTOR DEVELOPMENT

Ability

1. Youngster can see with sufficient clarity.
2. Youngster possesses ability to perceive depth or distance.
3. Youngster has adequate side vision/ peripheral vision.
4. Youngster can judge the speed of objects.



Points to Evaluate

- Can youngster see letters and numbers at least as well as you?
- Can youngster distinguish colors?
- Has youngster demonstrated adequate vision in other activities (riding bicycles, running, sports, or other recreational activities)?
- When looking at two objects in the distance, can youngster tell which is farther or closer?
- Can youngster see objects 90 degrees to each side while looking straight ahead?
- Does the youngster judge the speed of objects (fast, medium, slow) that agree with your judgments? (For example, a car on the highway, a train moving past a crossing, a dog running, people walking.)

PART 4

Ability

5. Youngster can state the distances of objects in terms of feet, yard, miles.
6. Youngster can follow movement of objects.
7. Youngster can visualize distances as displayed by a picture or photograph.
8. Youngster can follow a moving object while accomplishing hand manipulation.
9. Youngster can describe cause-and-effect experiences.



Points to Evaluate

- Can youngster tell how many feet or yards it is from the house to the road?
- Can youngster tell how wide a hallway is, or the width of a room?
- Can youngster follow the path of such things as: a hit or thrown baseball, a moving car, objects in a video game?
- Can youngster estimate distance between objects in a family photograph?
- Can youngster estimate distance between objects when looking at a landscape picture?
- Can youngster dribble a basketball without looking at it?
- Can youngster manipulate video game controls while following objects on a screen?
- Can youngster describe a minor injury he or she received and correctly describe the causes?
- Can youngster describe settings or situations that can produce injury if precautions are not taken?

Ability

10. Youngster can concentrate on more than one element at a time in solving a puzzle or problem.
11. Youngster can maintain relative spans of attention when given a variety of stimuli.



Points to Evaluate

Can youngster describe what may cause injury when doing such things as running, swimming, bicycling, riding in a car?

Can youngster pick out or describe several items within a picture?

Can youngster assemble a puzzle without unusual problems or delays?

Can youngster describe what to do if a house fire should occur?

Can youngster complete school homework assignments without being easily distracted?

Can youngster assemble more difficult puzzles; for example, a nature scene or picture?

PART 4

PHYSICAL DEVELOPMENT

Ability

1. Youngster can sit comfortably on the motorcycle and reach the controls easily.

2. Youngster has sufficient strength and familiarity to operate the controls with ease.



Points to Evaluate

- Can youngster place his or her feet firmly on the footpegs?
- Do the youngster's fingers reach comfortably around the handlebars and control levers? How about with the handlebars turned? How about in different seating positions?
- Can youngster stand (with knees slightly bent) and have a few inches of space from the seat?
- Can youngster easily reach the foot controls?
- Can youngster dress with proper protective gear including putting on helmet and fastening the chin strap?

While sitting on the vehicle, can youngster:

- Squeeze the hand controls?
- Operate the shift lever (if equipped)?
- Operate the choke and fuel valve with ease?
- Press the brake lever with sufficient pressure
- Operate the controls without looking at them?

Ability

3. Youngster is sufficiently coordinated.



Points to Evaluate

Can youngster walk a "balance beam" (2" x 4" x 8') flat on floor?

Can youngster ride a bicycle, rollerskate or skateboard safely?

Can youngster walk on tiptoes for 10 feet?

Can youngster jump rope?

Can youngster catch a ball with hands rather than with arms?

4. Youngster has sufficient endurance to maintain strength over a period of time.

Can youngster play outdoor games without fatigue?

Can youngster participate in indoor games and sports without tiring before other youngsters?

PART 4

SOCIAL/EMOTIONAL DEVELOPMENT

Ability	✓	Points to Evaluate
1. Youngster can understand and follow rules.	<input type="checkbox"/>	Does youngster follow rules established at home?
	<input type="checkbox"/>	Do teachers say that the youngster follows rules?
	<input type="checkbox"/>	Does youngster listen and respond to adult supervision?
	<input type="checkbox"/>	Does youngster comprehend the importance and seriousness of having rules and regulations?
2. Youngster generally will obey parents and supervisors.	<input type="checkbox"/>	Does youngster avoid challenging authority or rebelling when rules are imposed?
3. Youngster controls behavior according to expectations?	<input type="checkbox"/>	Does youngster show evidence of self-control...doesn't get easily frustrated or upset?
	<input type="checkbox"/>	Does youngster understand consequences associated with certain actions (like not wearing a safety belt in the car)?
	<input type="checkbox"/>	Does youngster think about results before performing some action (like crossing the street, hitting or throwing a ball)?

Ability

4. Youngster understands other youngsters may be permitted to do what he/she may not be allowed to.

5. Youngster can give reasons and/or solutions to problems seen in the environment.

6. Youngster can make decisions based on reality and not fantasy.



Points to Evaluate

- Does youngster recognize unsafe actions of other youngsters?
- Does youngster appreciate being safer than others?
- Does youngster accept rules that are more stringent than what other youngsters have to follow?

- Can youngster explain how land (or grass) gets worn?
- Can youngster explain how even small damage to land can take years to recover?
- Can youngster distinguish between untouched land and used land?

- Can youngster complete a task in a step-by-step fashion (assemble a toy, clean a room)?
- Does youngster comprehend real injury as opposed to “cartoon” injury?
- Does youngster respond with logical solutions when asked to solve a problem?

PART 4

REASONING AND DECISION-MAKING ABILITY

Ability

1. Youngster comprehends that interaction with others and things can result in injury.
2. Youngster has a basic understanding of what being careful means.



Points to Evaluate

- Can youngster describe how and why a person received physical injury or pain?
- Does youngster notice impending accidents or potential injury-producing events, such as in sports activities or bicycle riding?
- Can youngster explain why it takes distance to stop?
- Can youngster explain how moving at even low speed can result in injury if stopped suddenly or by hitting something?
- Does youngster know why rules are established?
- Does youngster notice or recognize others being careful in action-oriented activities?
- Does youngster notice professional athletes use protective gear as part of their sport?

Ability

3. Youngster understands that rules are made to reduce injury and provide long-term enjoyment.
4. Youngster has basic understanding of the physical limitations of stopping and turning.



Points to Evaluate

- Can youngster explain the reason for rules at home or school?
- Does youngster understand the value of prevention? Of wearing protective gear?
- Can youngster recognize that not following rules can eliminate future fun and enjoyment?
- Can youngster explain what may happen if moving too fast while going around a curve on a bicycle? On a skateboard? On an off-highway motorcycle?

FINAL NOTE

TO PARENTS

We hope this booklet has helped you and your youngster take a “safety first” approach to off-highway motorcycle riding. All off-highway motorcycle riders must use good judgment and be responsible. It is up to YOU to set a good example about motorcycle safety. You must help your youngster ride sensibly and safely at all times.

After your youngster has mastered the riding skills in this booklet and has matured to a higher level of skills, he or she may be ready to practice more advanced riding. The Motorcycle Safety Foundation’s *Tips & Practice Guide for the Off-Highway Motorcyclist* booklet provides information about riding on hills, riding across slopes, and other more advanced skills. Youngsters should have a good understanding of riding skills before using unfamiliar areas. They

should ride on flat areas, gentle hills, and gradual slopes. Be sure that your youngster rides slowly over unfamiliar terrain to locate and avoid bumps, holes, and other possible hazards. You should check the area first.

The Motorcycle Safety Foundation also recommends a video program, *The MSF DirtBike School: Learn to Ride Safely*. It demonstrates and discusses responsible riding practices.

It is also recommended that you and your youngster read the information in the owner’s manual. To find out more about rider education and off-highway motorcycle safety programs offered, or to order the video or publications, contact the **Motorcycle Safety Foundation at 2 Jenner, Suite 150, Irvine CA 92618, 949.727.3227 or visit dirtbikeschool.com**

BRAKES - The parts of a motorcycle which allow the operator to slow down or stop the machine.

BRAKE LEVER - The hand brake located on the handlebar.

BRAKE PEDAL - The foot brake which is operated by the right foot.

CABLES - Heavy insulated wires. There are two kinds: mechanical and electrical. Brake cables are mechanical. The headlamp cable is electrical.

CARBURETOR - Device which provides the engine the proper mixture of fuel and air.

CHOKE - A device which enriches the mixture of gasoline and air supplied to the engine for cold engine starting.

CLUTCH LEVER - The hand lever used to disengage the clutch when changing gears.

DRIVE CHAIN - The chain which connects the engine to the rear axle to give a motorcycle motion.

ENGINE STOP SWITCH - Switch used to stop the engine without removing the hands from the handlebars.

EXHAUST - Leftover gases from the combustion process that come out of the tailpipe when the motorcycle engine is running. Exhaust contains deadly carbon monoxide gases.

EYE PROTECTION - Goggles or a shatter resistant shield worn over the eyes while riding to protect against dust, flying insects, or other debris. Such eye protection, when tinted, may be effective against bright sun or snow-glare conditions.

FINE-C - A pre-start routine. A way to remember the pre-start routine:

F - Fuel valve on

I - Ignition on

N - Neutral

E - Engine stop switch in run position

C - Choke

FOOTPEGS - Pivoting pegs on which a motorcycle operator should keep his/her feet while riding.

FUEL VALVE - A valve, usually hand operated, with an on, off and "reserve" position. Controls gasoline flow to the carburetor.

GLOSSARY

HANDLEBAR - The metal bar attached to the front end of the motorcycle that turns the front wheel for steering. Many of the controls for the motorcycle are located on the handlebar.

HELMET - The most important protective clothing to be worn when operating a motorcycle. It covers the head and helps protect against skull fracture or brain injury in an accident.

OFF-HIGHWAY or OFF-ROAD VEHICLE - Any vehicle, including off-highway motorcycles and ATVs, which is restricted by law from operating on public roads.

OHM - Off-Highway Motorcycle

PSI - Refers to air pressure in the tires and stands for "Pounds per Square Inch."

READING THE TERRAIN - Looking well ahead while riding, anticipating hazards.

SHIFT LEVER - On those motorcycles equipped with a shift lever, it allows the operator to change gears. The shift lever is operated by the left foot.

TAILPIPE - That part of the exhaust system which expels waste gases.

THROTTLE - The control operated by the right hand which controls the engine speed.

TRACTION - Tread friction between the ground and the tires.

TRANSMISSION - Mechanism used to transmit power from the engine to the wheels.

ANSWERS

NAME THE MOTORCYCLE PARTS (Typical)

1. Clutch lever
2. Hand brake lever
3. Foot brake lever or pedal
4. Throttle
5. Choke or enrichening device
6. Engine stop switch
7. Gas cap/tank vent
8. Starter (kick)
9. Electric starter (if equipped)

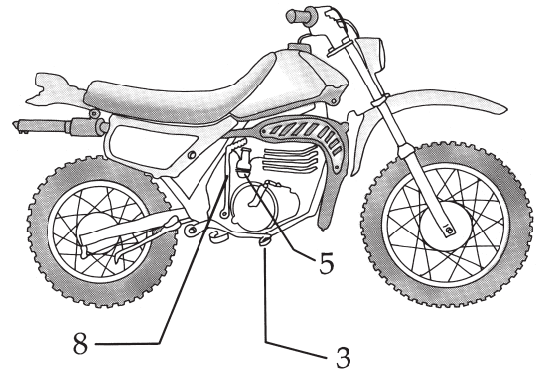
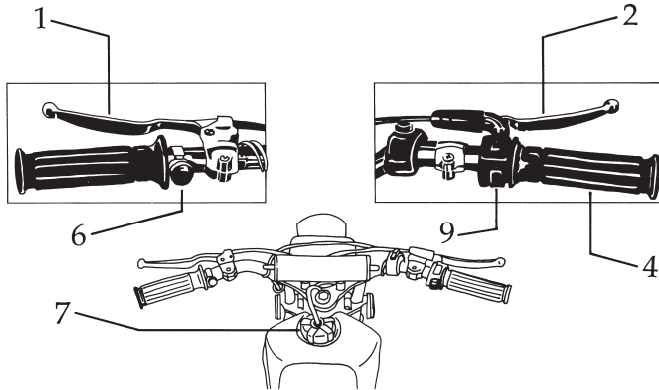

NOTES

NOTES



**For the rider training location nearest you,
call: (877) 288-7093**

dirtbikeschool.com

© 2015 Motorcycle Safety Foundation, Inc.
2 Jenner, Suite 150 • Irvine, CA 92618
(949) 727-3227 • msf-usa.org

PN MSPU3444NC00

A

Accessories	9
Air filter	
cleaning	61
installation	60
removal	60
Air filter box	
cleaning	61
Air suspension XACT 5235	28
Antifreeze	
checking	91
Article number	
fork	12
Auxiliary substances	9

B

Basic chassis setting	
rider's weight, checking with	28
Brake discs	
checking	71
Brake fluid	
adding front brake	73
adding to rear brake	80
Brake fluid level	
of the front brake, checking	72
rear brake, checking	79
Brake lining retainers	
checking the rear brake	81
of front brake, checking	74
Brake linings	
checking the rear brake	81
of front brake, checking	74
of the front brake, changing	75
of the rear brake, changing	82

C

Capacity	
coolant	93-94, 120
fuel	25, 120
gear oil	104, 120
Carburetor	
adjusting the idle speed	97
idle setting	97
installation	108
removal	106
Chain	
checking	66
cleaning	64
Chain guide	
adjusting	68

checking	66
----------------	----

Chain tension	
checking	65
setting	65

Choke	16
Cleaning	111-112

Clutch	
setting	99
setting, checking	98

Clutch cover	
clutch cover, removing	99
installing the clutch cover	102

Coolant	
changing	94
draining	92
refilling	93

Coolant level	
checking	91-92

Cooling system	91
-----------------------------	----

Customer service	9
-------------------------------	---

E

Engine	
running in	20

Engine number	12
----------------------------	----

Engine sprocket	
checking	66

Engine sprocket cover	
installation	63
removal	63

Environment	8
--------------------------	---

F

Figures	9
----------------------	---

Foot brake lever	16
adjusting the basic position	79
free travel, adjusting	78
free travel, checking	78

Fork	
article number	12

Fork article number	12
----------------------------------	----

Fork legs	
air pressure, adjusting	34
bleeding	43
checking basic setting	34
dust boots, cleaning	44
installation	46
removal	45

Fork protector	
installing	45

removing 44

Frame

checking 69

Frame label 12

Frame protector

installation 60

removal 59

Front fender

installing 55

removing 55

Front wheel

installing 85

removing 85

Fuel tank

installation 52

removal 51

Fuel tank filler cap

closing 15

opening 14

Fuel tap 15

Fuel, oils, etc. 9

G

Gear oil

adding 104

changing 103

Gear oil level

checking 103

H

Hand brake lever 14

basic position, adjusting 71

checking play 71

Handlebar position 36

adjusting 36

High-speed compression damping

adjusting the shock absorber 30

I

Implied warranty 9

Intended use 6

K

Kick starter lever 16

L

Left side cover

installation 56

removal 55

Link fork

checking 69

Lower triple clamp

installing 48

removing 47

Low-speed compression damping

adjusting the shock absorber 29

M

Main silencer

changing rock wool 62

installation 62

removal 61

Manufacturer warranty 9

Misuse 6

Motorcycle

cleaning 111

lift stand, raising with 43

lift stand, removing from 43

O

Owner's Manual 8

P

Play in throttle cable

adjusting 96

checking 96

Plug-in stand 16

Preparing for use

advice on preparing for first use 18

after storage 114

checks and maintenance measures when
preparing for use 21

Protective clothing 7

R

Rear sprocket

checking 66

Rear wheel

installing 87

removing 86

Rebound damping

adjusting the fork 35

adjusting the shock absorber 30

Refueling

fuel 24

Rider sag

setting 33

Right side cover

installation 57

removal 56

Rubber grip

checking 70

S		Throttle grip	14
Safe operation	7	Tire condition	
Seat		checking	88
mounting	59	Tire pressure	
removing	59	checking	89
Seat height		Transporting	24
adjusting on the fork	39	Troubleshooting	115-116
adjusting on the frame	40	U	
adjusting on the shock absorber	38	Use definition	6
adjustment options	38	V	
Service	9	Vehicle identification number	12
Service hour counter	17	View of vehicle	
Service schedule	26-27	left side	10
Shock absorber		right	11
adjusting the spring preload	32	W	
checking riding sag	32	Work rules	8
installation	58		
removal	58		
static sag, checking	31		
Shock absorber article number	13		
Side cover			
preparing for securing	57		
Spare parts	9		
Spoke tension			
checking	89		
Start number plate			
installation	54		
removal	54		
Starting	21		
Steering head bearing			
lubricating	51		
Steering head bearing play			
adjusting	50		
checking	50		
Stop button	14		
Storage	113		
T			
Technical specifications			
capacities	120		
carburetor	118		
chassis	120		
chassis tightening torques	122		
engine	117		
engine tightening torques	117		
fork	121		
shock absorber	122		
tires	121		
Throttle cable routing			
checking	69		



3240036en

24.09.2024

