



OWNER'S MANUAL 2024

MC 50

Art. no. 3215154en



GASGAS

Congratulations on your decision to purchase a GASGAS motorcycle. You are now the owner of a state-of-the-art sports vehicle that will continue to give you and your child pleasure for a long time if you maintain it properly.

We hope your child has many safe and enjoyable rides!

Enter the serial numbers of your vehicle below.

Vehicle identification number (📖 p. 12)	Dealer's stamp
Engine number (📖 p. 12)	

The Owner's Manual contained the latest information for this model series at the time of publication. However, minor differences due to further developments in design cannot be ruled out completely.

All specifications contained herein are non-binding. GASGAS GmbH specifically reserves the right to modify or delete technical specifications, prices, colors, forms, materials, services, designs, equipment, etc., without prior notice and without specifying reasons, to adapt these to local conditions, as well as to stop production of a particular model without prior notice. GASGAS GmbH accepts no liability for delivery options, deviations from figures and descriptions, misprints, and other errors. The models portrayed partly contain special equipment that does not belong to the regular scope of supply.

© 2024 GASGAS GmbH, Mattighofen Austria

All rights reserved

Reproduction, even in part, as well as copying of all kinds, is permitted only with the express written permission of the copyright owner.



ISO 9001(12 100 6061)

GASGAS applies quality assurance processes that lead to the highest possible product quality as defined in the ISO 9001 international quality management standard.

Issued by: TÜV SÜD Management Service GmbH

REG.NO. 12 100 6061

GASGAS GmbH

Stallhofnerstraße 3











5230 Mattighofen, Austria

This document is valid for the following models:

MC 50 (F0001X4)



TABLE OF CONTENTS

1	MEANS OF REPRESENTATION	5	8.4	Riding	21
1.1	Symbols used	5	8.5	Braking	22
1.2	Formats used	5	8.6	Stopping, parking	22
2	SAFETY ADVICE	6	8.7	Transporting	23
2.1	Use definition – intended use	6	8.8	Refueling	23
2.2	Misuse	6	9	SERVICE SCHEDULE	25
2.3	Safety advice	6	9.1	Additional information	25
2.4	Degrees of risk and symbols	6	9.2	Service schedule	25
2.5	Tampering warning	6	10	TUNING THE CHASSIS	27
2.6	Safe operation	7	10.1	Checking the basic chassis setting with rider's weight	27
2.7	Protective clothing	7	10.2	Air suspension XACT 5235	27
2.8	Work rules	8	10.3	Compression damping of the shock absorber	28
2.9	Environment	8	10.4	Adjusting the low-speed compression damping of the shock absorber	28
2.10	Owner's Manual	8	10.5	Adjusting the high-speed compression damping of the shock absorber	28
3	IMPORTANT NOTES	9	10.6	Adjusting the rebound damping of the shock absorber	29
3.1	Manufacturer warranty, implied warranty	9	10.7	Measuring the dimension of the rear wheel unloaded	30
3.2	Fuel, auxiliary substances	9	10.8	Checking the static sag of the shock absorber	30
3.3	Spare parts, accessories	9	10.9	Checking the rider sag of the shock absorber	31
3.4	Service	9	10.10	Adjusting the spring preload of the shock absorber 	31
3.5	Figures	9	10.11	Adjusting the riding sag 	32
3.6	Customer service	9	10.12	Checking the basic setting of the fork	33
4	VIEW OF VEHICLE	10	10.13	Adjusting the fork air pressure	33
4.1	View of vehicle, left side (example)	10	10.14	Adjusting the rebound damping of the fork	35
4.2	View of vehicle, right side (example)	11	10.15	Handlebar position	35
5	SERIAL NUMBERS	12	10.16	Adjusting the handlebar position 	35
5.1	Vehicle identification number	12	11	SEAT HEIGHT	37
5.2	Frame label	12	11.1	Seat height adjustment options	37
5.3	Engine number	12	11.2	Adjusting the seat height on the shock absorber 	37
5.4	Fork article number	12	11.3	Adjusting the seat height on the fork 	38
5.5	Shock absorber article number	13	11.4	Adjusting the seat height on the frame 	39
6	CONTROLS	14	12	SERVICE WORK ON THE CHASSIS	42
6.1	Hand brake lever	14	12.1	Raising the motorcycle with a lift stand	42
6.2	Throttle grip	14	12.2	Removing the motorcycle from the lift stand	42
6.3	Stop button	14	12.3	Bleeding the fork legs	42
6.4	Opening the fuel tank filler cap	14	12.4	Cleaning the dust boots of the fork legs	43
6.5	Closing the fuel tank filler cap	15	12.5	Removing the fork protector	44
6.6	Fuel tap	15	12.6	Installing the fork protector	44
6.7	Choke	16	12.7	Removing the fork legs 	45
6.8	Kick starter lever	16	12.8	Installing the fork legs 	45
6.9	Foot brake lever	16	12.9	Removing the lower triple clamp 	46
6.10	Plug-in stand	16	12.10	Installing the lower triple clamp 	47
7	PREPARING FOR USE	17			
7.1	Advice on preparing for first use	17			
7.2	Running in the engine	19			
8	RIDING INSTRUCTIONS	20			
8.1	Checks and maintenance measures when preparing for use	20			
8.2	Starting the vehicle	20			
8.3	Starting off	21			

12.11	Checking the steering head bearing play ...	49	13.11	Adding rear brake fluid	78
12.12	Adjusting the steering head bearing play	49	13.12	Checking that the brake linings of the rear brake are secured	79
12.13	Lubricating the steering head bearing	50	13.13	Changing the rear brake linings	79
12.14	Removing the fuel tank	50	14	WHEELS, TIRES	83
12.15	Installing the fuel tank	51	14.1	Removing the front wheel	83
12.16	Removing the start number plate	53	14.2	Installing the front wheel	83
12.17	Installing the start number plate	53	14.3	Removing the rear wheel	84
12.18	Removing front fender	53	14.4	Installing the rear wheel	85
12.19	Installing the front fender	54	14.5	Checking the tire condition	86
12.20	Removing the left side cover	54	14.6	Checking tire pressure	87
12.21	Installing the left side cover	55	14.7	Checking the spoke tension	87
12.22	Removing the right side cover	55	15	COOLING SYSTEM	89
12.23	Installing the right side cover	56	15.1	Cooling system	89
12.24	Removing the shock absorber	56	15.2	Checking the antifreeze and coolant level	89
12.25	Installing the shock absorber	56	15.3	Checking the coolant level	90
12.26	Removing the seat	57	15.4	Draining the coolant	90
12.27	Mounting the seat	57	15.5	Refilling with coolant	91
12.28	Removing the frame protector	58	15.6	Changing the coolant	92
12.29	Installing the frame protector	58	16	TUNING THE ENGINE	94
12.30	Removing the air filter	58	16.1	Checking the play in the throttle cable	94
12.31	Installing the air filter	59	16.2	Adjusting the play in the throttle cable	94
12.32	Cleaning the air filter and air filter box	59	16.3	Carburettor – idle speed	95
12.33	Removing the main silencer	60	16.4	Carburetor – adjusting the idle speed	95
12.34	Installing the main silencer	61	16.5	Checking the clutch setting	96
12.35	Changing the rock wool on the main silencer	61	16.6	Removing the clutch cover	97
12.36	Removing the engine sprocket cover	62	16.7	Adjusting the clutch	97
12.37	Installing the engine sprocket cover	62	16.8	Installing the clutch cover	100
12.38	Checking the chain for dirt	62	17	SERVICE WORK ON THE ENGINE	101
12.39	Cleaning the chain	63	17.1	Checking the gear oil level	101
12.40	Checking the chain tension	63	17.2	Changing the gear oil	101
12.41	Adjusting the chain tension	64	17.3	Adding the gear oil	102
12.42	Checking the chain, rear sprocket, engine sprocket, and chain guide	65	18	CARBURETOR	104
12.43	Adjusting the chain guide	67	18.1	Removing the carburetor	104
12.44	Checking the frame	67	18.2	Installing the carburetor	106
12.45	Checking the link fork	67	19	CLEANING, CARE	109
12.46	Checking the throttle cable routing	67	19.1	Cleaning the motorcycle	109
12.47	Checking the rubber grip	68	20	STORAGE	111
13	BRAKE SYSTEM	69	20.1	Storage	111
13.1	Adjusting the basic position of the hand brake lever	69	20.2	Preparing for use after storage	112
13.2	Checking the brake discs	69	21	TROUBLESHOOTING	113
13.3	Checking the front brake fluid level	70	22	TECHNICAL SPECIFICATIONS	115
13.4	Adding front brake fluid	71	22.1	Engine	115
13.5	Checking that the brake linings of the front brake are secured	72	22.2	Engine tightening torques	115
13.6	Changing the front brake linings	72	22.3	Carburetor with carburetor tuning	116
13.7	Checking the free travel of the foot brake lever	75	22.3.1	Carburetor tuning (Option: Low seat position)	116
13.8	Adjusting the free travel of the foot brake lever	76			
13.9	Adjusting the basic position of the foot brake lever	76			
13.10	Checking the rear brake fluid level	77			

TABLE OF CONTENTS

22.3.2	Carburetor tuning (Option: High seat position).....	117
22.4	Capacities.....	118
22.4.1	Gear oil	118
22.4.2	Coolant	118
22.4.3	Fuel	118
22.5	Chassis	118
22.6	Tires	119
22.7	Fork.....	119
22.8	Shock absorber.....	119
22.9	Chassis tightening torques	120
23	SUBSTANCES.....	122
24	AUXILIARY SUBSTANCES.....	124
25	STANDARDS	126
26	LIST OF ABBREVIATIONS.....	127
	INDEX	128

1.1 Symbols used

The meaning of specific symbols is described below.



Indicates an expected reaction (e.g., of a work step or a function).



Indicates an unexpected reaction (e.g., of a work step or a function).



Indicates work that requires expert knowledge and technical understanding. In the interest of the safety of your child, have these jobs performed in an authorized GASGAS Motorcycles workshop. Your motorcycle will be cared for there to the highest degree by specially trained experts using the special tools required.



Indicates a page reference (more information is provided on the specified page).



Indicates information with more details or tips.



Indicates the result of a testing step.



Indicates the end of an activity, including potential reworking.



Indicates a voltage measurement.



Indicates a current measurement.

1.2 Formats used

The typographical formats used in this document are explained below.

Proprietary name	Indicates a proprietary name.
Name®	Indicates a protected name.
Brand™	Indicates a brand available on the open market.
<u>Underlined terms</u>	Refer to technical details of the vehicle or indicate technical terms, which are explained in the glossary.

2.1 Use definition – intended use

This vehicle has been designed and built to withstand the normal stresses and strains of racing. This vehicle complies with the currently valid regulations and categories of the top international motorsports organizations.



Info

Only operate this vehicle in closed-off areas remote from public road traffic.

2.2 Misuse

The vehicle must only be used as intended.

Dangers can arise for people, property and the environment through use not as intended.

Any use of the vehicle beyond the intended and defined use constitutes misuse.

Misuse also includes the use of operating and auxiliary fluids which do not meet the required specification for the respective use.

2.3 Safety advice

A number of safety instructions need to be followed to operate the product described safely. Therefore read this instruction and all further instructions included carefully. The safety instructions are highlighted in the text and are referred to at the relevant passages.



Info

Various information and warning labels are attached in prominent locations on the product described. Do not remove any information or warning labels. If they are missing, you or others may not recognize dangers and may therefore be injured.

2.4 Degrees of risk and symbols



Danger

Identifies a danger that will immediately and invariably lead to fatal or serious permanent injury if the appropriate measures are not taken.



Warning

Identifies a danger that is likely to lead to fatal or serious injury if the appropriate measures are not taken.



Caution

Identifies a danger that may lead to minor injuries if the appropriate measures are not taken.

Note

Identifies a danger that will lead to considerable machine and material damage if the appropriate measures are not taken.



Note

Indicates a danger that will lead to environmental damage if the appropriate measures are not taken.

2.5 Tampering warning

Tampering with the noise control system is prohibited. Federal law prohibits the following acts or the causing thereof:

- 1 The removal or rendering inoperative by any person other than for purposes of servicing, repair, or replacement, of any device or element of design incorporated into any new vehicle for the purpose of noise control prior to its sale or delivery to the ultimate purchaser or while it is in use, or
- 2 the use of the vehicle after such device or element of design has been removed or rendered inoperative by any person.

Among those acts presumed to constitute tampering are the acts listed below:

- 1 Removal or puncturing of the main silencers, baffles, header pipes or any other components which conduct exhaust gases.
- 2 Removal or puncturing of parts of the intake system.
- 3 Lack of proper maintenance.
- 4 Replacing moving parts of the vehicle, or parts of the exhaust system or intake system, with parts other than those specified by the manufacturer.

2.6 Safe operation



Danger

Danger of accidents A rider who is not fit to ride poses a danger to him or herself and others.

- Do not operate the vehicle if you are not fit to ride due to alcohol, drugs or medication.
- Do not operate the vehicle if you are physically or mentally impaired.



Danger

Danger of poisoning Exhaust gases are toxic and inhaling them may result in unconsciousness and death.

- Always make sure there is sufficient ventilation when running the engine.
- Use effective exhaust extraction when starting or running the engine in an enclosed space.



Warning

Danger of burns Some vehicle components become hot when the vehicle is operated.

- Do not touch any parts such as the exhaust system, radiator, engine, damper, or brake system before the vehicle parts have cooled down.
- Let the vehicle parts cool down before you perform any work on the vehicle.

Only operate the vehicle when it is in perfect technical condition, in accordance with its intended use, and in a safe and environmentally compatible manner.

The vehicle should only be used by trained persons.

Have malfunctions that impair safety immediately eliminated by an authorized GASGAS Motorcycles workshop.

Adhere to the information and warning labels on the vehicle.

2.7 Protective clothing



Warning

Risk of injury Missing or poor protective clothing presents an increased safety risk.

- Ensure your child wears appropriate protective clothing such as helmet, boots, gloves as well as trousers and a jacket with protectors on all rides.
- Always use protective clothing for your child that is in good condition and meets the legal requirements.
- When you ride a motorcycle, set an example for your child and wear suitable protective clothing.

In the interest of your own safety, GASGAS recommends that you only operate the vehicle while wearing suitable protective clothing.

2.8 Work rules

Unless specified otherwise, the ignition must be turned off during all work (models with ignition lock, models with transponder key) or the motor must be at a standstill (models without ignition lock or transponder key).

Special tools are necessary for certain tasks. If these special tools are not included in the scope of supply of the vehicle, the special tools can be ordered using the specified article number. Example: bearing puller (15112017000)

Unless otherwise noted, normal conditions apply to all tasks and descriptions.

Ambient temperature	20 °C (68 °F)
Ambient air pressure	1,013 mbar (14.69 psi)
Relative air humidity	60 ± 5 %

During assembly, use new parts to replace parts which cannot be reused (e.g. self-locking screws and nuts, expansion screws, seals, sealing rings, O-rings, pins, and lock washers).

In the case of certain screw connections, a thread locker (e.g., **Loctite**[®]) is required. Observe the manufacturer's instructions.

If a thread locker (e.g. **Precote**[®]) has already been applied to a new part, do not apply any additional thread locker.

After disassembly, clean the parts that are to be reused and check them for damage and wear. Change damaged or worn parts.

Ensure that the work area is clean and clean components before disassembly if necessary. Penetrating dirt can lead to increased wear and consequential damage.

After completing a repair or service work, check the operating safety of the vehicle.

2.9 Environment

If you use your motorcycle responsibly, you can ensure that problems and conflicts do not occur. To protect the future of the motorcycle sport, make sure that you use your motorcycle legally, be environmentally aware, and respect the rights of others.

When disposing of used oil, other operating and auxiliary fluids, and used components, comply with the laws and regulations of the respective country.

Because motorcycles are not subject to the EU regulations governing the disposal of used vehicles, there are no legal regulations that pertain to the disposal of an end-of-life motorcycle. Your authorized GASGAS Motorcycles dealer will be glad to advise you.

2.10 Owner's Manual

It is important that you read this Owner's Manual carefully and completely before your child makes his or her first trip. The Owner's Manual contains useful information and many tips for you and your child on how to operate, handle, and service your motorcycle. This is the only way for you to find out how to ideally tune the vehicle and how to protect your child from injury.

Tip

Store the Owner's Manual on your terminal device, for example, so that you can read it whenever you need to.

If you would like to know more about the vehicle or have questions on the material you read, please contact an authorized GASGAS Motorcycles dealer.

The Owner's Manual is an important component of the vehicle. If the vehicle is sold, the Owner's Manual must be downloaded again by the new owner.

The Owner's Manual can be downloaded several times using the QR code or the link on the delivery certificate.

The Owner's Manual is also available for download from your authorized GASGAS Motorcycles dealer and on the GASGAS Motorcycles website. A printed copy can also be ordered from your authorized GASGAS Motorcycles dealer.

Int'l International GASGAS website: <http://www.gasgas.com>

3.1 Manufacturer warranty, implied warranty

The work prescribed in the service schedule must be carried out in an authorized GASGAS Motorcycles workshop only and confirmed in the electronic proof of service, as otherwise no warranty claims will be recognized. Damage or secondary damage caused by tampering with and/or conversions on the vehicle are not covered by the manufacturer warranty.

3.2 Fuel, auxiliary substances



Note

Environmental hazard Improper handling of fuel is a danger to the environment.

- Do not allow fuel to enter the groundwater, the soil, or the sewage system.

Use fuels and auxiliary substances in accordance with the Owner's Manual and specification.

3.3 Spare parts, accessories

For the safety of your child, only use spare parts and accessory products that are approved and/or recommended by GASGAS and have them installed by an authorized GASGAS Motorcycles workshop. GASGAS accepts no liability for other products and any resulting damage or loss.

Certain spare parts and accessory products are specified in parentheses in the descriptions. Your authorized GASGAS Motorcycles dealer will be glad to advise you.

The latest news **GASGAS Technical Accessories** on your vehicle can be found on the GASGAS Motorcycles website. Int'l GASGAS website: <http://www.gasgas.com>

3.4 Service

A prerequisite for perfect operation and prevention of premature wear is that the service, care, and tuning work on the engine and chassis is properly carried out as described in the Owner's Manual. An incorrect suspension setting can lead to damage and breakage of chassis components.

Use of the vehicle under difficult conditions, such as on sand or on wet, dusty and muddy surfaces, can result in significantly increased wear of components, such as the drive train, brake system, air filter or suspension components. For this reason, it may be necessary to inspect or replace parts before the next scheduled service.

It is imperative that you adhere to the stipulated run-in times and service intervals. If you observe these exactly, you will ensure a much longer service life for your motorcycle.

The relevant mileage or time interval is whichever occurs first.

3.5 Figures

The figures contained in the manual may depict special equipment.

In the interest of clarity, some components may be shown disassembled or may not be shown at all. It is not always necessary to disassemble the component to perform the activity in question. Please follow the instructions in the text.

3.6 Customer service

Your authorized GASGAS Motorcycles dealer will be happy to answer any questions you may have regarding your vehicle and GASGAS.

A list of authorized GASGAS Motorcycles dealers can be found on the GASGAS Motorcycles website.

Int'l GASGAS website: <http://www.gasgas.com>

4 VIEW OF VEHICLE

4.1 View of vehicle, left side (example)



K01479-10

- ❶ Valve for fork airpump
- ❷ Stop button (📖 p. 14)
- ❸ Fuel tank filler cap
- ❹ Fuel tap (📖 p. 15)
- ❺ Quick release of seat
- ❻ Shock absorber compression adjustment
- ❼ Choke

4.2 View of vehicle, right side (example)



K01480-10

- ❶ Fork rebound adjustment
- ❷ Throttle grip (📖 p. 14)
- ❸ Hand brake lever (📖 p. 14)
- ❹ Vehicle identification number (📖 p. 12)
- ❺ Clutch adjuster
- ❻ Foot brake lever (📖 p. 16)
- ❼ Kick starter lever (📖 p. 16)
- ❽ Shock absorber rebound adjuster
- ❾ Level viewer for brake fluid, rear

5 SERIAL NUMBERS

5.1 Vehicle identification number

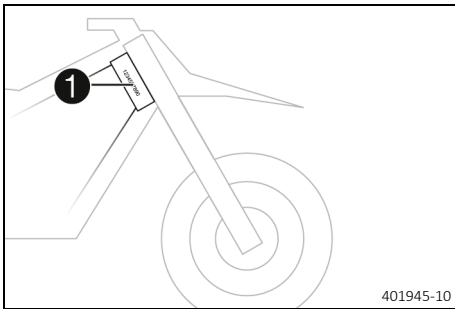

The vehicle identification number ❶ is stamped on the right side of the steering head.

5.2 Frame label

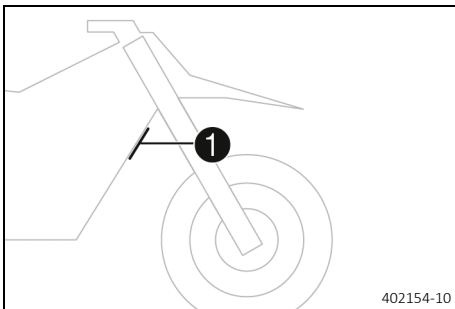

Frame label ❶ is located on the front frame tube.

5.3 Engine number

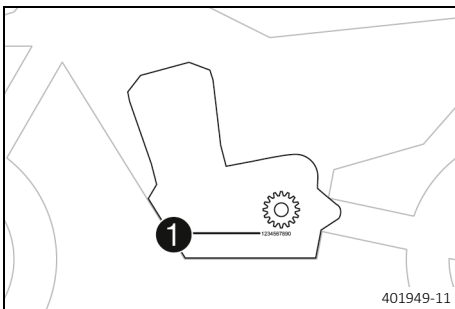

The engine number ❶ is located on the left side of the engine under the engine sprocket.

5.4 Fork article number

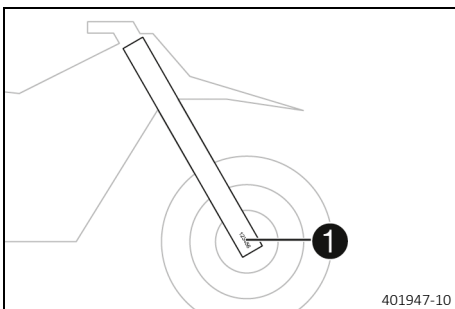

The fork article number ❶ is stamped on the outside of the axle clamp.

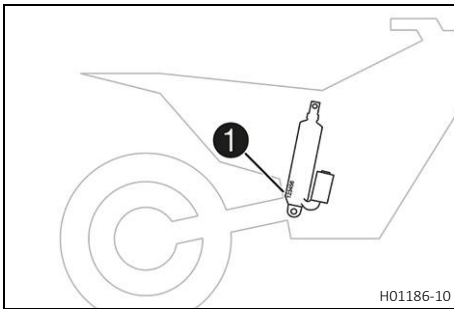
5.5 Shock absorber article number

The shock absorber article number **1** is stamped on the bottom of the shock absorber toward the right-hand side.

6.1 Hand brake lever

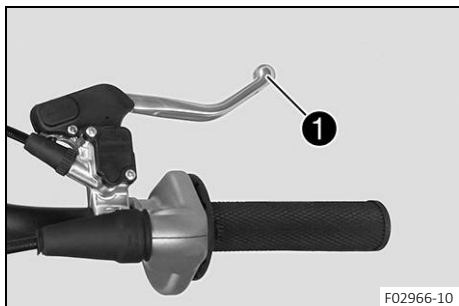

Hand brake lever **1** is fitted on the right side of the handlebar. The hand brake lever is used to activate the front brake.

6.2 Throttle grip

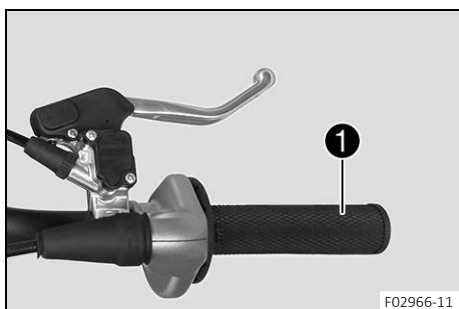

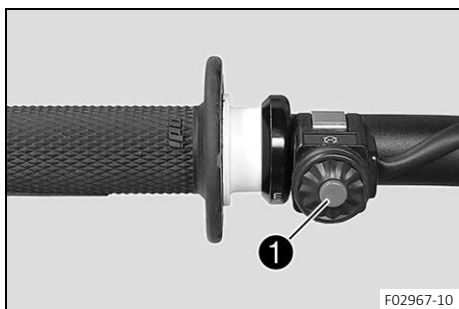

Throttle grip **1** is fitted on the right side of the handlebar.

6.3 Stop button



The stop button **1** is fitted on the left side of the handlebar.

Possible states

- The stop button  is in the basic position – In this position, the ignition circuit is closed and the engine can be started.
- Stop button  pressed – In this position, the ignition circuit is interrupted, a running engine stops, and a non-running engine will not start.

6.4 Opening the fuel tank filler cap



Danger

Fire hazard Fuel is highly flammable.

The fuel in the fuel tank expands when warm and can escape if overfilled.

- Do not fuel the vehicle in the vicinity of open flames or lit cigarettes.
- Switch off the engine for refueling.
- Make sure that no fuel is spilled; particularly not on hot parts of the vehicle.
- If any fuel is spilled, wipe it off immediately.
- Observe the specifications for refueling.



Warning

Danger of poisoning Fuel is harmful to health.

- Avoid skin, eye and clothing contact with fuel.
- Immediately consult a doctor if you swallow fuel.
- Do not inhale fuel vapors.
- Rinse the affected area immediately with plenty of water in the event of contact with the skin.
- Rinse the eyes thoroughly with water, and consult a doctor in case of fuel contact with the eyes.
- Change your clothing if fuel spills on them.
- Keep fuels correctly in a suitable canister, and out of the reach of children.



Note

Environmental hazard Improper handling of fuel is a danger to the environment.

- Do not allow fuel to enter the groundwater, the soil, or the sewage system.



- Turn fuel tank filler cap ① counterclockwise and lift it off.

6.5 Closing the fuel tank filler cap

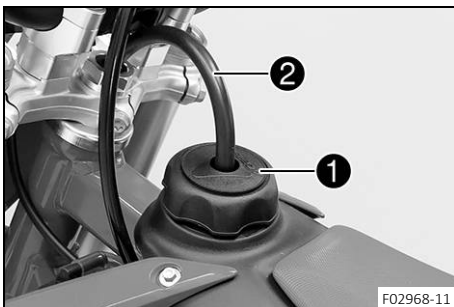

- Mount fuel tank filler cap ① and turn it clockwise until the fuel tank is tightly closed.



Info

Route fuel tank breather hose ② without kinks.

6.6 Fuel tap



Fuel tap ① is on the left of the fuel tank.

Possible states

- Fuel tap is closed – The knurled screw is turned all the way clockwise. Fuel cannot flow out of the fuel tank.
- Fuel tap is open – The knurled screw is turned all the way counterclockwise. Fuel can flow out of the fuel tank.

6.7 Choke

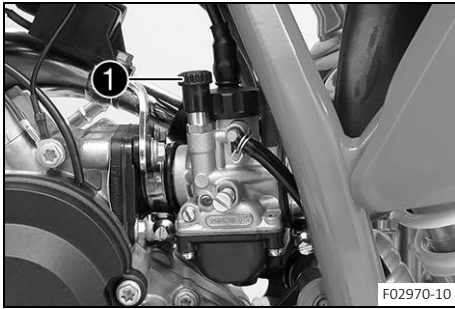

Choke **1** is fitted on the left side of the carburetor. Activating the choke function frees a drill hole in the carburetor through which the engine can draw extra fuel. This results in a richer fuel-air mixture, which is needed for a cold start.

i **Info**

If the engine is warm, the choke function must be deactivated.

Possible states

- Choke function activated – The choke lever is pulled out to the stop.
- Choke function deactivated – The choke lever is pushed in to the stop.

6.8 Kick starter lever

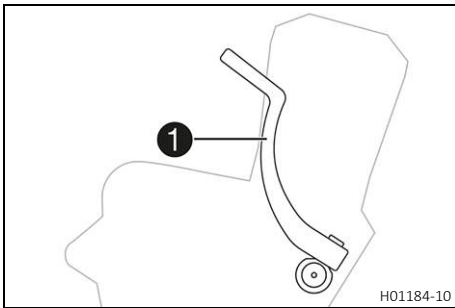

Kick starter lever **1** is fitted on the right side of the engine. The kick starter lever can be swiveled.

i **Info**

Before riding, swing the kick starter lever inwards towards the engine.

6.9 Foot brake lever

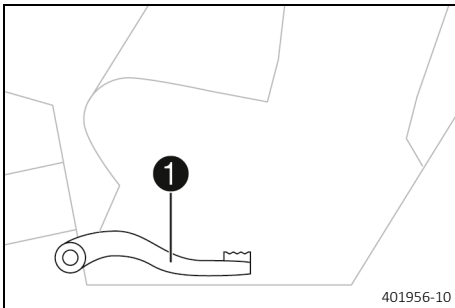

Foot brake lever **1** is located in front of the right footrest. The rear brake is engaged with the foot brake lever.

6.10 Plug-in stand

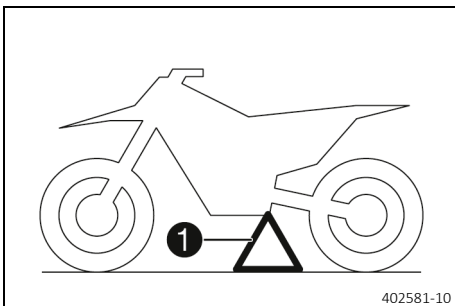

The fixture for plug-in stand **1** is located on the frame on the left side of the vehicle.

The plug-in stand is used to park the motorcycle.

i **Info**

Remove the plug-in stand before riding.

7.1 Advice on preparing for first use

 **Warning**
Danger of accidents A lack of physical and mental readiness on the part of the child poses a major risk.
 Children often underestimate or fail to recognize dangerous situations.

- Your child must already be able to ride a bicycle.
- Your child must be able to put the vehicle upright independently after a fall.
- Your child must understand that regulations and instructions from you or from other guardians must be followed.
- Make it clear to your child that they should not, under any circumstances, operate the vehicle without supervision.
- Make it clear to your child that he or she may only drive at speeds corresponding to the child's riding abilities and the road conditions.
- Do not ask too much of your child.
 Make sure that their stamina, riding technique and motivation are at the necessary levels.
- Only let your child ride on the vehicle if they are physically and mentally ready.

 **Warning**
Risk of injury Missing or poor protective clothing presents an increased safety risk.

- Ensure your child wears appropriate protective clothing such as helmet, boots, gloves as well as trousers and a jacket with protectors on all rides.
- Always use protective clothing for your child that is in good condition and meets the legal requirements.
- When you ride a motorcycle, set an example for your child and wear suitable protective clothing.

 **Warning**
Danger of crashing Different tire tread patterns on the front and rear wheel impair the handling characteristic.
 Different tire tread patterns can make the vehicle significantly more difficult to control.

- Make sure that only tires with a similar tire tread pattern are fitted to the front and rear wheel.

 **Warning**
Danger of accidents An unadapted riding style constitutes a major risk.

- Ensure that your child adapts the riding speed to the road conditions and to his or her riding abilities.

 **Warning**
Danger of accidents The vehicle is not designed to carry passengers.

- Make it clear to your child that he or she must not carry a passenger.

 **Warning**
Danger of accidents The brake system fails in the event of overheating.
 If the foot brake lever is not released, the brake linings drag continuously.

- Ensure that your child raises his or her foot from the foot brake lever if he or she does not want to brake.

 **Warning**
Danger of accidents The suspension components will become damaged or destroyed if overloaded.

- Do not exceed the maximum permissible weight of the rider.

 **Warning**
Risk of injury People who act without authorization may not be familiar with the vehicle.

- Do not leave the vehicle unattended if the engine is running.
- Protect the vehicle against access by unauthorized persons.



Info

When using the motorcycle, remember that others may be disturbed by excessive noise.

- Ensure that the pre-sale inspection work has been carried out by an authorized GASGAS Motorcycles workshop.
 - ✓ You will receive a delivery certificate when the vehicle is handed over.
- Read through the entire Owner's Manual together with your child before riding for the first time.



Info

Pay special attention to the safety instructions and to the risk of injury.

Explain to your child the techniques of riding and falling, e.g., how shifting weight can influence handling characteristics.

- Familiarize your child with the controls.
- Adjust basic position of the hand brake lever. (📖 p. 69)
- Adjust the basic position of the foot brake lever. 🖐️ (📖 p. 76)
- Before using the vehicle for the first time, ensure that the basic settings of the chassis are suitable for the weight of your child.



Info

Contact your authorized GASGAS Motorcycles workshop for information on different throttle variants.

- Allow your child to become accustomed to the handling of the motorcycle on suitable terrain, preferably on a large, open meadow.



Info

To give your child a feeling for the brake system, you should push your child at first. Do not start the engine until your child is able to apply the necessary front brake pressure.

Initially, let your child ride to another person who can help your child stop and turn.

- Erect obstacles for your child to navigate around so that your child becomes accustomed to handling the vehicle.
- Your child should also try to ride as slowly as possible and in a standing position to get a better feeling for the motorcycle.
- Your child should not ride on terrain that exceeds your child's capabilities and experience.
- Your child should hold the handlebar firmly with both hands and keep his or her feet on the footrests when riding.
- Make sure the maximum permissible weight of the rider is not exceeded.

Guideline

Maximum rider weight	45 kg (99 lb.)
Maximum rider size	< 130 cm (< 51.2 in)

- Check the spoke tension. (📖 p. 87)



Info

The spoke tension must be checked after half an hour of operation.

- Run the engine in. (📖 p. 19)

7.2 Running in the engine

- During the running-in time, do not exceed the specified engine load.

Guideline

Maximum engine performance	
During the first 3 operating hours	< 70 %
During the first 5 operating hours	< 100 %



Info

The use of a service hour counter is recommended in order to be able to check the mileage at any time.

- Avoid fully opening the throttle.



8.1 Checks and maintenance measures when preparing for use

i Info

Before every trip, check the condition of the vehicle and ensure that it is safe to operate. The vehicle must be in perfect technical condition when it is being operated.

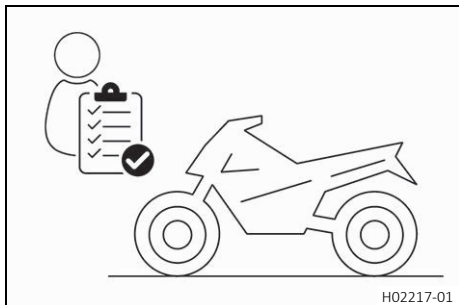

- Check the gear oil level. (📖 p. 101)
- Check the front brake fluid level. (📖 p. 70)
- Check the rear brake fluid level. (📖 p. 77)
- Check that the brake linings of the front brake are secured. (📖 p. 72)
- Check that the brake linings of the rear brake are secured. (📖 p. 79)
- Check that the brake system is functioning properly.
- Check the coolant level. (📖 p. 90)
- Check the chain for dirt. (📖 p. 62)
- Check the chain, rear sprocket, engine sprocket, and chain guide. (📖 p. 65)
- Check the chain tension. (📖 p. 63)
- Check the tire condition. (📖 p. 86)
- Check tire pressure. (📖 p. 87)
- Check the spoke tension. (📖 p. 87)

i Info

The spoke tension must be checked regularly as incorrect spoke tension will strongly impair riding safety.

- Clean the dust boots of the fork legs. (📖 p. 43)
- Bleed the fork legs. (📖 p. 42)
- Check the air filter.
- Check the settings of all controls and ensure that they can be operated smoothly.
- Check all screws, nuts, and hose clips regularly for tightness.
- Check the fuel level.

8.2 Starting the vehicle



Danger

Danger of poisoning Exhaust gases are toxic and inhaling them may result in unconsciousness and death.

- Always make sure there is sufficient ventilation when running the engine.
- Use effective exhaust extraction when starting or running the engine in an enclosed space.

Note

Engine failure High rpm with a cold engine negatively impacts the lifespan of the engine.

- Ensure that the engine is always warmed up at low engine speeds.

i Info

If the motorcycle is unwilling to start, the cause can be old fuel in the float chamber. The flammable elements of the fuel evaporate after a long time of standing.

If the float chamber is filled with fresh fuel, the engine starts immediately.

Preliminary work

- Raise the motorcycle with a lift stand. (📖 p. 42)

The motorcycle has been out of use for more than 1 week

- Empty the carburetor float chamber. 🛠️
- Turn the knurled screw on the fuel tap all the way counterclockwise.
 - ✓ Fuel can flow from the fuel tank to the carburetor.

The engine is cold

- Pull the choke knob up all the way to the stop and turn it by a max. ¼ turn.
- Press the kick starter lever robustly through its full range.

**Info**

Do not open the throttle.

**Info**

If the motorbike does not start after 5 actuations of the kick-start lever, apply the front brake and lift the motorbike up by the rear wheel for 3 seconds.

Final steps

- Remove the motorcycle from the lift stand. (📖 p. 42)

**8.3 Starting off****Info**

The plug-in stand must be removed before riding.

- Open the throttle carefully.

**8.4 Riding****Info**

If unusual noises occur while riding, stop immediately, switch off the engine, and contact an authorized GASGAS Motorcycles workshop.

- If the choke function has been activated, deactivate it after the engine has warmed up.
- After reaching maximum speed by fully opening the throttle grip, turn the throttle back so it is ¾ open. This will barely reduce the speed, but fuel consumption will be considerably lower.
- Your child should always open the throttle only as much as the engine can handle – abruptly opening the throttle increases fuel consumption.
- Your child should switch off the engine if prolonged operation at idle speed or while stationary is imminent.

Guideline

≥ 2 min



8.5 Braking



Warning

Danger of accidents Excessively forceful application of the brakes blocks the wheels.

- Explain to your child that he or she must adapt the braking to the traffic situation and the road conditions.



Warning

Danger of accidents A spongy pressure point on the front or rear brake reduces braking efficiency.

- Check the brake system and do not allow your child to continue riding until the problem is eliminated. (Your authorized GASGAS Motorcycles workshop will be glad to help.)



Warning

Danger of accidents Moisture and dirt impair the brake system.

- Explain to your child that he or she must brake carefully several times to dry out and remove dirt from the brake linings and the brake discs.

- On sandy, wet, or slippery surfaces, use mostly the rear brake if possible.
- Try to complete the braking procedure before riding into a curve.

8.6 Stopping, parking



Warning

Risk of injury People who act without authorization may not be familiar with the vehicle.

- Do not leave the vehicle unattended if the engine is running.
- Protect the vehicle against access by unauthorized persons.



Warning

Danger of burns Some vehicle components become hot when the vehicle is operated.

- Do not touch any parts such as the exhaust system, radiator, engine, damper, or brake system before the vehicle parts have cooled down.
- Let the vehicle parts cool down before you perform any work on the vehicle.

Note

Material damage The vehicle may be damaged by incorrect procedure when parking.

Significant damage may be caused if the vehicle rolls away or falls over.

The components for parking the vehicle are designed only for the weight of the vehicle.

- Park the vehicle on a firm and level surface.
- Ensure that nobody sits on the vehicle when the vehicle is parked on a stand.

Note

Fire hazard Hot vehicle components pose a fire hazard and explosion risk.

- Do not park the vehicle near to materials which are highly flammable or explosive.
- Allow the vehicle to cool down before covering it.

- Apply the brakes on the motorcycle.
- Press and hold the stop button  while the engine is idling until the engine stops.
- Turn the knurled screw on the fuel tap all the way clockwise.
- Park the motorcycle on firm ground.

8.7 Transporting

Note

Material damage The vehicle may be damaged by incorrect procedure when parking.

Significant damage may be caused if the vehicle rolls away or falls over.

The components for parking the vehicle are designed only for the weight of the vehicle.

- Park the vehicle on a firm and level surface.
- Ensure that nobody sits on the vehicle when the vehicle is parked on a stand.

Note

Fire hazard Hot vehicle components pose a fire hazard and explosion risk.

- Do not park the vehicle near to materials which are highly flammable or explosive.
- Allow the vehicle to cool down before covering it.

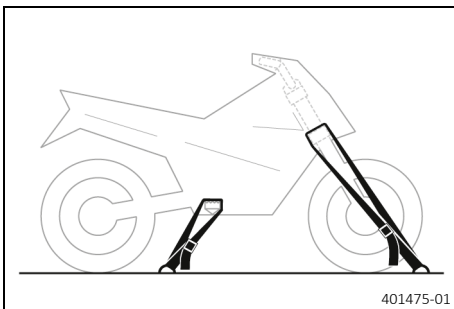

- Switch off the engine.
- Use tension belts or other suitable devices to secure the motorcycle against falling over or rolling away.

8.8 Refueling



Danger

Fire hazard Fuel is highly flammable.

The fuel in the fuel tank expands when warm and can escape if overfilled.

- Do not fuel the vehicle in the vicinity of open flames or lit cigarettes.
- Switch off the engine for refueling.
- Make sure that no fuel is spilled; particularly not on hot parts of the vehicle.
- If any fuel is spilled, wipe it off immediately.
- Observe the specifications for refueling.



Warning

Danger of poisoning Fuel is harmful to health.

- Avoid skin, eye and clothing contact with fuel.
- Immediately consult a doctor if you swallow fuel.
- Do not inhale fuel vapors.
- Rinse the affected area immediately with plenty of water in the event of contact with the skin.
- Rinse the eyes thoroughly with water, and consult a doctor in case of fuel contact with the eyes.
- Change your clothing if fuel spills on them.



Note

Environmental hazard Improper handling of fuel is a danger to the environment.

- Do not allow fuel to enter the groundwater, the soil, or the sewage system.

- Switch off the engine.
- Open the fuel tank filler cap. (📖 p. 14)

8 RIDING INSTRUCTIONS

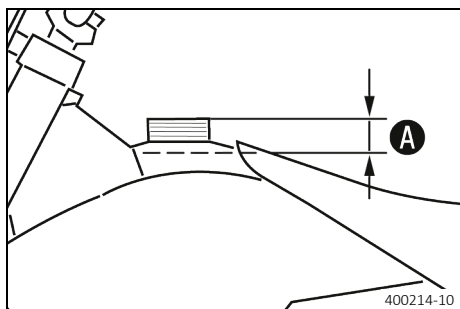

- Fill the fuel tank with fuel up to a maximum of level **A**.

Guideline

Dimension A	35 mm (1.38 in)	
Fuel tank capacity, approx.	2.3 l (2.4 qt.)	Super unleaded (95 octane) mixed with 2-stroke engine oil (1:60) (📖 p. 123)

- Close the fuel tank filler cap. (📖 p. 15)

9.1 Additional information

Any further work that results from the compulsory work or from the recommended work must be ordered separately and invoiced separately.

Different service intervals may apply in your country, depending on the local operating conditions.

Individual service intervals and scopes may change in the course of technical developments. The most up-to-date service schedule is available for authorized GASGAS Motorcycles dealers for the electronic proof of service. Your authorized GAS-GAS Motorcycles dealer will be glad to advise you.

The use of a service hour counter is recommended in order to be able to check the mileage at any time.

Service hour counter (A54012920000)

9.2 Service schedule

	every 24 months				
	Every 90 operating hours				
	Every 45 operating hours				
	Every 15 operating hours				
	After 1 operating hour				
Check that the brake linings of the front brake are secured. (📖 p. 72)	○	●	●	●	●
Check that the brake linings of the rear brake are secured. (📖 p. 79)	○	●	●	●	●
Check the brake discs. (📖 p. 69)	○	●	●	●	●
Check the brake lines for damage and tightness.	○	●	●	●	●
Check the front brake fluid level. (📖 p. 70)	○	●	●		
Change the front brake fluid. 🛠️				●	●
Check the rear brake fluid level. (📖 p. 77)	○	●	●		
Change the rear brake fluid. 🛠️				●	●
Check the play of the handbrake lever.	○	●	●	●	●
Check the free travel of the foot brake lever. (📖 p. 75)	○	●	●	●	●
Check the idle speed. 🛠️	○	●	●	●	●
Change the gear oil. 🛠️ (📖 p. 101)	○	●	●	●	●
Check all hoses (e.g. fuel, cooling, bleeder, drainage hoses, etc.) and sleeves for cracking, tightness, and correct routing. 🛠️	○	●	●	●	●
Check the cables for damage and that there are no kinks in the routing. 🛠️	○	●	●	●	●
Check that the throttle cables are undamaged, routed without kinks, and set correctly.	○	●	●	●	●
Check the frame. 🛠️ (📖 p. 67)		●	●	●	
Check the link fork. 🛠️ (📖 p. 67)		●	●	●	
Check the fork bearing for play. 🛠️		●	●	●	
Check the shock absorber heim joint for play. 🛠️		●	●	●	
Check the tire condition. (📖 p. 86)	○	●	●	●	●
Check tire pressure. (📖 p. 87)	○	●	●	●	●
Check the wheel bearing for play. 🛠️		●	●	●	
Check the wheel hubs. 🛠️		●	●	●	
Check the rim run-out. 🛠️	○	●	●	●	
Check the spoke tension. (📖 p. 87)	○	●	●	●	
Check the chain, rear sprocket, engine sprocket, and chain guide. (📖 p. 65)	○	●	●	●	
Check the chain tension. (📖 p. 63)	○	●	●	●	●
Grease all moving parts (e.g., hand lever, chain, etc.) and check for smooth operation. 🛠️	○	●	●	●	●
Change the spark plug and spark plug connector. 🛠️		●	●	●	
Clean the air filter and air filter box. 🛠️ (📖 p. 59)	○	●	●	●	●
Change the rock wool on the main silencer. 🛠️ (📖 p. 61)			●	●	

9 SERVICE SCHEDULE

	every 24 months				
	Every 90 operating hours				
	Every 45 operating hours				
	Every 15 operating hours				
	After 1 operating hour				
Service the fork. 🛠️			●	●	
Perform the shock absorber service. 🛠️			●	●	
Check all screws, nuts, and hose clips for a tight fit. 🛠️	○	●	●	●	●
Check the clutch setting. 🛠️ (📖 p. 96)			●	●	●
Check the antifreeze and coolant level. (📖 p. 89)	○	●	●	●	
Change the coolant. 🛠️ (📖 p. 92)					●
Check the steering head bearing play. (📖 p. 49)	○	●			
Lubricate the steering head bearing. 🛠️ (📖 p. 50)			●	●	●
Check/set the carburetor components. 🛠️			●	●	●
Check the cylinder and piston. 🛠️			●	●	●
Perform minor engine service. (Check the clutch. Check the inlet membrane. Change the piston.) 🛠️			●	●	
Perform major engine service including removing and installing the engine. (Change the connecting rod, conrod bearing, and crank pin. Check the transmission. Change the crankshaft bearing. Change the intake flange. Change all engine bearings.) 🛠️					●
Final check: check the operating safety of the vehicle and take for a test ride. 🛠️	○	●	●	●	●
Enter electronic proof of service in the dealer portal. 🛠️	○	●	●	●	●

- One-time interval
- Periodic interval

10.1 Checking the basic chassis setting with rider's weight

i Info

When adjusting the basic chassis setting, first adjust the shock absorber and then the fork.

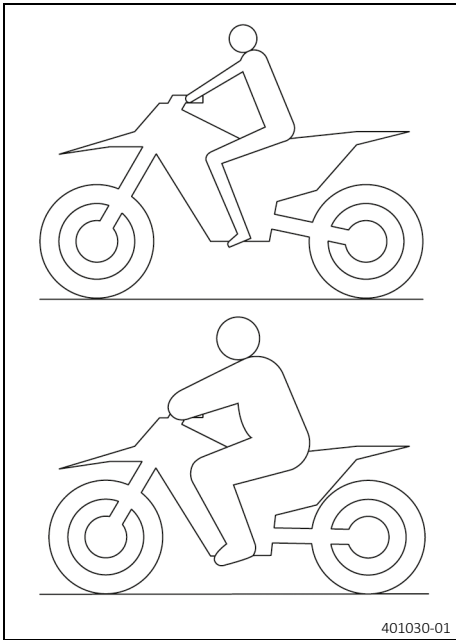

- For optimal motorcycle riding characteristics and to avoid damage to forks, shock absorbers, link fork and frame, the basic settings of the suspension components must match the rider's weight.
- This vehicle is delivered pre-set for a standard rider's weight (with full protective clothing).

Guideline

Standard rider weight	25 ... 35 kg (55 ... 77 lb.)
-----------------------	------------------------------

- If the rider's weight is above or below this range, the basic setting of the suspension components must be adjusted accordingly.
- Small weight differences can be compensated by adjusting the spring preload, but in the case of large weight differences, the springs must be replaced.



10.2 Air suspension XACT 5235

Air suspension **WP XACT 5235** is used in the fork.

In this system, suspension is located in the left fork leg and damping in the right fork leg.

As fork springs are no longer required, a significant weight advantage is achieved when compared to conventional forks. The response on slightly uneven surfaces is significantly improved.

In normal driving mode, suspension is provided exclusively by an air cushion. A steel spring is located in the left fork leg as an end stop.

i Info

If the fork is frequently overloaded, then the air pressure in the fork must be increased to avoid damage to the fork and frame.

The air pressure in the fork can be quickly adjusted to the rider's weight, surface conditions and the rider's preference using a fork airpump. The fork does not have to be dismantled. The time consuming mounting of harder or softer fork springs is not required.

If the air chamber loses air due to a damaged seal, the fork will still not sag. In this case the air is retained in the fork. The suspension travel is maintained as far as possible. The damping becomes harder and the riding comfort reduces.

The rebound damping can be adjusted.

The rebound adjustment is located at the upper end of the right fork leg.

10.3 Compression damping of the shock absorber

The compression damping of the shock absorber is divided into two ranges: high-speed and low-speed.

High-speed and low-speed refer to the compression speed of the rear wheel suspension and not to the vehicle speed.

The high-speed compression adjuster has an effect, for example, when landing after a jump: the rear wheel suspension compresses quickly.

The low-speed compression adjuster has an effect, for example, when riding over long ground swells: the rear wheel suspension compresses slowly.

These two ranges can be adjusted separately, although the transition between high-speed and low-speed is gradual. Thus, modifications in the high-speed range affect the compression damping in the low-speed range and vice versa.

10.4 Adjusting the low-speed compression damping of the shock absorber



Caution

Risk of injury Parts of the shock absorber will move around if the shock absorber is detached incorrectly.

The shock absorber is filled with highly compressed nitrogen.

- Please follow the description provided. (Your authorized GASGAS Motorcycles workshop will be glad to help.)



Info

The effect of the low-speed compression adjuster can be seen in slow to normal compression of the shock absorber.

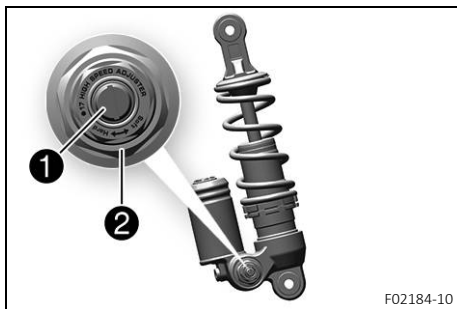

- Turn adjusting screw **1** clockwise with a screwdriver as far as the last perceptible click.



Info

Do not loosen fitting **2**!

- Turn counterclockwise by the number of clicks corresponding to the shock absorber type.

Guideline

Low-speed compression damping	
Comfort	18 clicks
Standard	15 clicks
Sport	12 clicks



Info

Turn clockwise to increase damping; turn counterclockwise to reduce damping.

10.5 Adjusting the high-speed compression damping of the shock absorber



Caution

Risk of injury Parts of the shock absorber will move around if the shock absorber is detached incorrectly.

The shock absorber is filled with highly compressed nitrogen.

- Please follow the description provided. (Your authorized GASGAS Motorcycles workshop will be glad to help.)



Info

The effect of the high speed compression adjuster can be seen in the fast compression of the shock absorber.

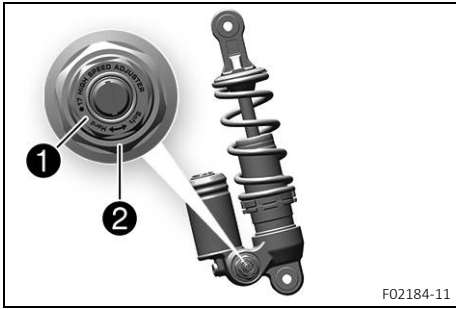

- Push the splash protector to the side.
- Using an open end wrench, turn adjusting screw ① clockwise all the way.

i Info
Do not loosen fitting ②!

- Turn counterclockwise by the number of turns corresponding to the shock absorber type.

Guideline

High-speed compression damping	
Comfort	2.5 turns
Standard	2 turns
Sport	1.5 turns

i Info
Turn clockwise to increase damping; turn counterclockwise to reduce damping.

- Position the splash protector.



10.6 Adjusting the rebound damping of the shock absorber



Caution

Risk of injury Parts of the shock absorber will move around if the shock absorber is detached incorrectly.

The shock absorber is filled with highly compressed nitrogen.

- Please follow the description provided. (Your authorized GASGAS Motorcycles workshop will be glad to help.)

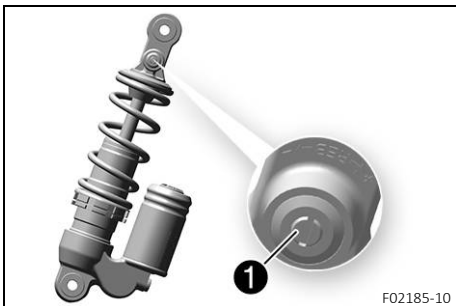

- Turn adjusting screw ① clockwise up to the last perceptible click.
- Turn counterclockwise by the number of clicks corresponding to the shock absorber type.

Guideline

Rebound damping	
Comfort	18 clicks
Standard	15 clicks
Sport	12 clicks

i Info
Turn clockwise to increase the damping; turn counterclockwise to reduce damping when the shock absorber rebounds.



10.7 Measuring the dimension of the rear wheel unloaded

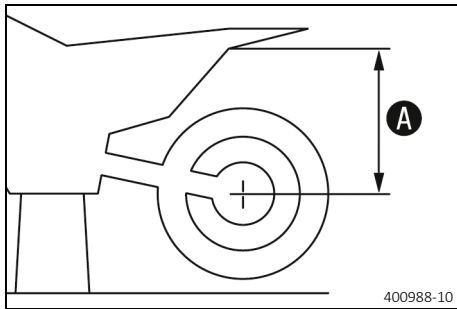

Preparatory work

- Raise the motorcycle with a lift stand. (📖 p. 42)

Main work

- Measure the vertical distance between the rear axle and a fixed point, such as a marking on the side cover.
- Note the value as dimension **A**.

Finishing work

- Remove the motorcycle from the lift stand. (📖 p. 42)

10.8 Checking the static sag of the shock absorber

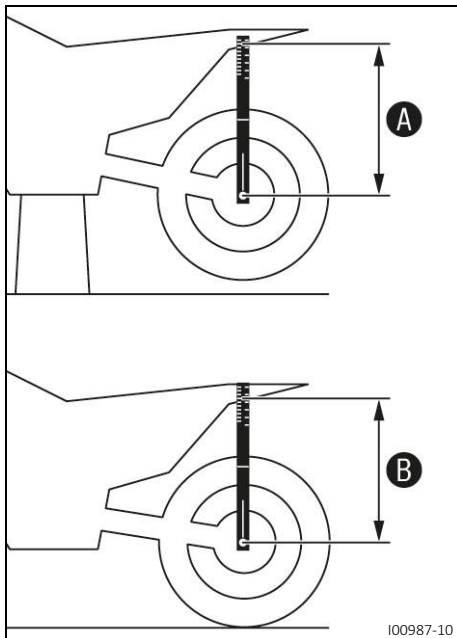

- Measure dimension **A** of rear wheel unloaded. (📖 p. 30)
- Hold the motorcycle upright with aid of an assistant.
- Measure the distance between rear axle and fixed point again.
- Note the value as dimension **B**.



Info

The static sag is the difference between measurements **A** and **B**.

- Check the static sag.

Static sag	30 mm (1.18 in)
------------	-----------------

- » If the static sag is less or more than the specified value:
 - Adjust the spring preload of the shock absorber. (📖 p. 31)

10.9 Checking the rider sag of the shock absorber

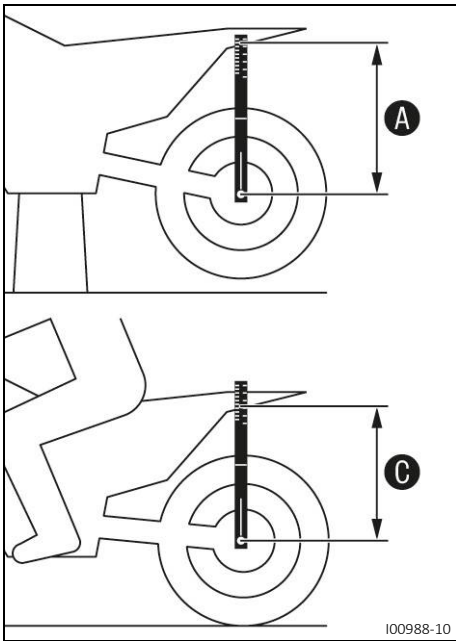

- Measure dimension **A** of rear wheel unloaded. (📖 p. 30)
- With another person holding the motorcycle, the rider, wearing full protective clothing, sits on the seat in a normal sitting position (feet on footrests) and bounces up and down a few times.
 - ✓ The rear wheel suspension levels out.
- Another person now measures the distance between the rear axle and the fixed point.
- Note the value as dimension **C**.

i Info
 The rider sag is the difference between measurements **A** and **C**.

- Check the rider sag.

Rider sag	80 mm (3.15 in)
-----------	-----------------

- » If the rider sag differs from the specified measurement:
 - Adjust the rider sag. (🔧📖 p. 32)

10.10 Adjusting the spring preload of the shock absorber 🔧



Caution

Risk of injury Parts of the shock absorber will move around if the shock absorber is detached incorrectly.

The shock absorber is filled with highly compressed nitrogen.

- Please follow the description provided. (Your authorized GASGAS Motorcycles workshop will be glad to help.)

Preparatory work

- Raise the motorcycle with a lift stand. (📖 p. 42)
- Remove the right side cover. (📖 p. 55)
- Remove the shock absorber. (🔧📖 p. 56)
- After removing the shock absorber, clean it thoroughly.

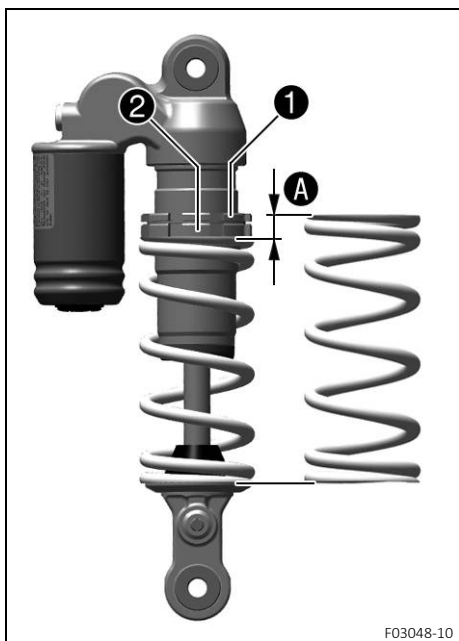

Main work

- Measure the full spring length while it is under tension and note down the value.
- Loosen retaining ring ①.
- Turn adjusting ring ② until the spring is no longer under tension.

Hook wrench (T304)
Hook wrench (T1533)

Info

If the spring cannot be fully released, the spring must be removed to accurately measure the spring length.

- Measure the total spring length while the spring is not under tension.
- Tension the spring by turning adjusting ring ② to specified dimension A.

Guideline

Spring preload	5 mm (0.2 in)
----------------	---------------

Info

The spring preload is the difference between the relaxed spring length and the tensioned spring length. Depending on the static sag and/or the rider sag, it may be necessary to increase or decrease the spring preload.

- Tighten retaining ring ①.

Finishing work

- Install the shock absorber. (🔧 p. 56)
- Install the right side cover. (🔧 p. 56)
- Remove the motorcycle from the lift stand. (🔧 p. 42)

10.11 Adjusting the riding sag 🛠️

Preparatory work

- Raise the motorcycle with a lift stand. (🔧 p. 42)
- Remove the right side cover. (🔧 p. 55)
- Remove the shock absorber. 🛠️ (🔧 p. 56)
- After removing the shock absorber, clean it thoroughly.

Main work

- Select and mount a suitable spring.

Guideline

Spring rate	
Weight of rider: 15 ... 25 kg (33 ... 55 lb.)	25 N/mm (143 lb/in)
Weight of rider (standard): 25 ... 35 kg (55 ... 77 lb.)	30 N/mm (171 lb/in)
Weight of rider: 35 ... 45 kg (77 ... 99 lb.)	35 N/mm (200 lb/in)

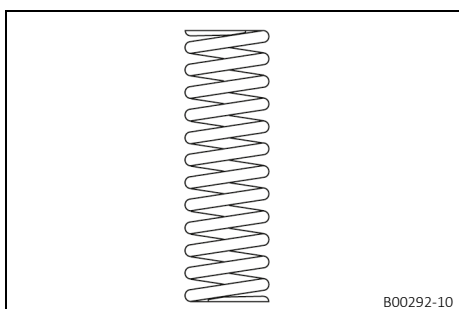

**Info**

The spring rate is shown on the outside of the spring. Smaller weight differences can be compensated by changing the spring preload.

Finishing work

- Install the shock absorber. (📖 p. 56)
- Install the right side cover. (📖 p. 56)
- Remove the motorcycle from the lift stand. (📖 p. 42)
- Check the static sag of the shock absorber. (📖 p. 30)
- Check the rider sag of the shock absorber. (📖 p. 31)
- Adjust the rebound damping of the shock absorber. (📖 p. 29)

**10.12 Checking the basic setting of the fork****Info**

For various reasons, no exact rider sag can be determined for the fork.

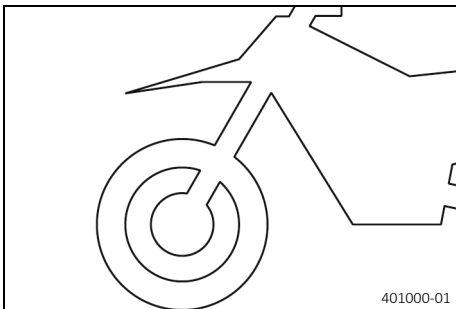

- Smaller differences in the rider's weight can be compensated for by the fork air pressure.
- However, if the fork frequently bottoms out (hard end stop on compression), the fork air pressure must be increased, within the specified values, to avoid damage to the fork and frame.

**10.13 Adjusting the fork air pressure****Warning**

Danger of accidents Modifications to the suspension setting may seriously alter the handling characteristic.

Modifications which are not coordinated with others to the suspension setting may cause a serious deterioration in the handling characteristic and overload components.

- Only make adjustments within the recommended range.
- Make sure your child rides slowly to start with after making adjustments in order that he or she can assess the new handling characteristic.

**Info**

Check or adjust the air pressure under the same conditions at the earliest 5 minutes after switching off the engine. The air suspension is located in the left fork leg. The rebound damping is located in the right fork leg.

Preparatory work

- Raise the motorcycle with a lift stand. (📖 p. 42)

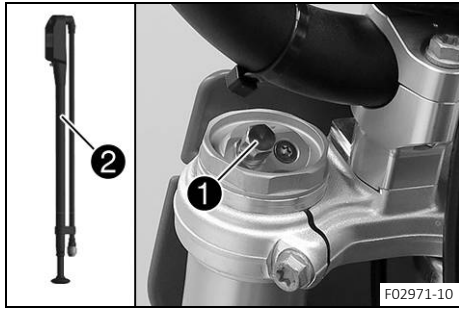

Main work

- Remove protection cap **1**.
- Push together fork airpump **2** fully.

Fork airpump (79412966100)



Info

The fork airpump is included as part of the motorcycle's accessory pack.

- Connect the fork airpump to the left fork leg.
 - ✓ The fork airpump indicator switches on automatically.
 - ✓ A little air escapes from the fork leg when connecting.



Info

This is due to the volume of the hose and not due to a defect in the fork airpump or the fork.

Observe the accompanying instructions for GASGAS technical accessories.

- Adjust the air pressure as specified.

Guideline

Air pressure	2 bar (29 psi)
Gradual changing of the air pressure in steps of	0.2 bar (3 psi)
Minimum air pressure	1.4 bar (20 psi)
Maximum air pressure	4 bar (58 psi)



Info

Never adjust the air pressure to a value outside the stated range.

- Disconnect the fork airpump from the left fork leg.
 - ✓ When disconnecting, excess pressure will escape from the hose – the fork leg itself does not lose any air.
 - ✓ The fork airpump indicator switches off automatically after 80 seconds.
- Mount the protection cap.



Info

Only mount the protection cap by hand.

Finishing work

- Remove the motorcycle from the lift stand. (📖 p. 42)

10.14 Adjusting the rebound damping of the fork

i Info
The hydraulic rebound damping determines the fork suspension behavior.



- Turn adjuster ① clockwise all the way.

i Info
Adjuster ① is located at the upper end of the right fork leg.

- Turn counterclockwise by the number of clicks corresponding to the fork type.

Guideline

Rebound damping	
Comfort	15 clicks
Standard	12 clicks
Sport	10 clicks

i Info
Turn clockwise to increase the damping; turn counterclockwise to reduce damping when the shock absorber rebounds.



10.15 Handlebar position

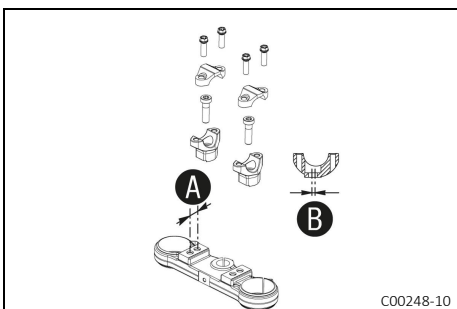

On the upper triple clamp, there are 2 holes at a distance of **A** to each other.

Hole distance A	16 mm (0.63 in)
------------------------	-----------------

The holes on the handlebar supports are placed at a distance of **B** from the center.

Hole distance B	3.5 mm (0.138 in)
------------------------	-------------------

The handlebar supports can be mounted in four different positions. This allows the handlebar to be mounted in the most comfortable position for the rider.

10.16 Adjusting the handlebar position

! Warning
Danger of accidents A repaired handlebar poses a safety risk.

If the handlebar is bent or straightened, the material becomes fatigued. The handlebar may break as a result.

- Change the handlebar if the handlebar is damaged or bent.

10 TUNING THE CHASSIS

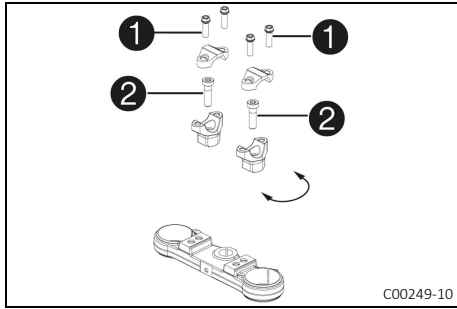

- Remove screws ❶. Take off the handlebar clamps. Remove the handlebar and lay it to one side.



Info

Cover the components to protect them against damage. Do not kink the cables and lines.

- Remove screws ❷. Take off handlebar supports.
- Place handlebar supports in required position. Mount and tighten screws ❷.

Guideline

Screw, handlebar support	M10	40 Nm (29.5 lbf ft) Loctite®243™
--------------------------	-----	--

- Position the handlebar.



Info

Make sure the cables and wiring are positioned correctly.

- Position the handlebar clamps. Mount screws ❶ and tighten evenly.

Guideline

Screw, handlebar clamp	M8	20 Nm (14.8 lbf ft)
------------------------	----	---------------------



Info

Make sure the installed gaps are even.

11.1 Seat height adjustment options

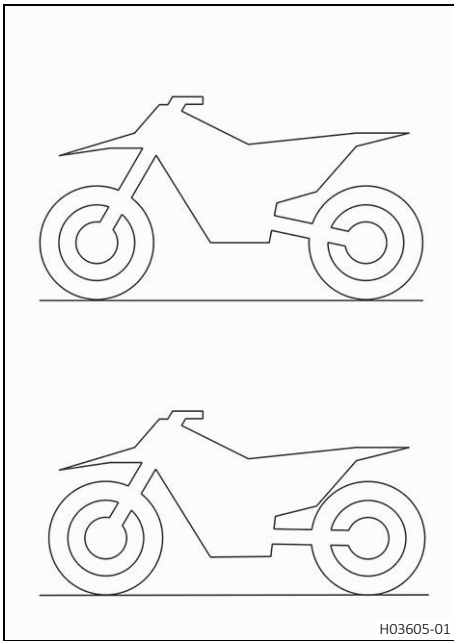

This vehicle offers several options for adjusting the seat height to the rider's height. The seat height can be changed with the mounting position of the fork, shock absorber, and frame.

i Info

When adjusting the seat height on the fork and shock absorber, make sure that the vehicle is as straight as possible after completing the work.

If the seat height on the shock absorber is set low, the fork should be pushed through further and vice versa.

11.2 Adjusting the seat height on the shock absorber



Warning

Danger of accidents Modifications to the suspension setting may seriously alter the handling characteristic.

- Make sure your child rides slowly to start with after making adjustments in order that he or she can assess the new handling characteristic.

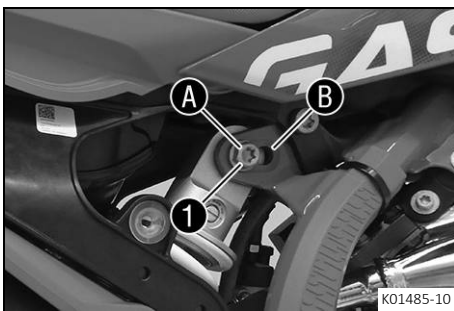

Preparatory work

- Raise the motorcycle with a lift stand. (📖 p. 42)
- Remove the right side cover. (📖 p. 55)

Main work

- Hold the rear wheel with the link fork and remove screw **1**.
- Position the shock absorber according to the required seat height.

Guideline

High seat position	A
Low seat position	B

- Mount and tighten screw **1**.

Guideline

Screw, top shock absorber	M10	45 Nm (33.2 lbf ft) Loctite® 243™
---------------------------	-----	---

Finishing work

- Install the right side cover. (📖 p. 56)
- Remove the motorcycle from the lift stand. (📖 p. 42)

11.3 Adjusting the seat height on the fork 🛠️



Warning

Danger of accidents Modifications to the suspension setting may seriously alter the handling characteristic.

- Make sure your child rides slowly to start with after making adjustments in order that he or she can assess the new handling characteristic.



Info

The seat height can be infinitely adjusted by pushing the fork legs through.

If the seat height is adjusted on the fork, the seat height should also be adjusted on the shock absorber.

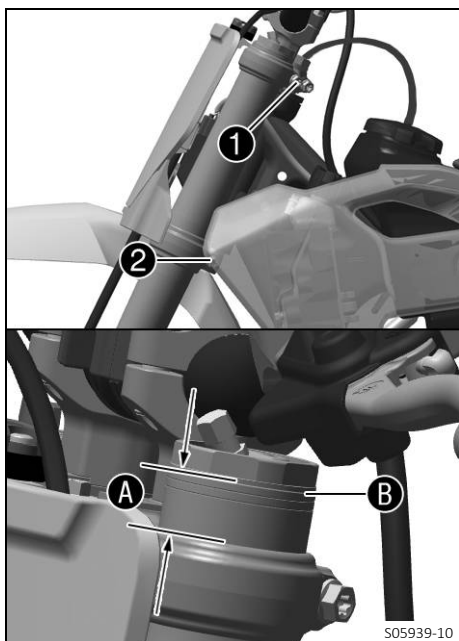

Preparatory work

- Raise the motorcycle with a lift stand. (📖 p. 42)
- Remove the front wheel. 🛠️ (📖 p. 83)

Main work

- Loosen screw ①.
- Loosen screw ②.
- Position the fork leg according to the required seat height.

Guideline

Condition

Seat position as low as possible, fork fully inserted

Maximum distance A between lower edge of screw cap and upper edge of triple clamp	18 mm (0.71 in)
--	-----------------

Condition

Seat position as high as possible, fork pulled out completely

Bottom edge of screw cap B closes flush with the upper edge of the triple clamp
--

Position the fork leg only within the described range.

- Tighten screw ②.

Guideline

Screw, bottom triple clamp	M8	15 Nm (11.1 lbf ft)
----------------------------	----	---------------------

- Tighten screw ①.

Guideline

Screw, top triple clamp	M8	20 Nm (14.8 lbf ft)
-------------------------	----	---------------------

- Repeat the procedure on the other fork leg.

Guideline

Position both fork legs equally.

Finishing work

- Install the front wheel. 🛠️ (📖 p. 83)

11.4 Adjusting the seat height on the frame

Preparatory work

- Remove the seat. (p. 57)
- Turn the knurled screw on the fuel tap all the way clockwise.
- Remove the fuel tank. (p. 50)
- Remove the right side cover. (p. 55)
- Remove main silencer. (p. 60)

Main work

- Loosen hose clip ①.

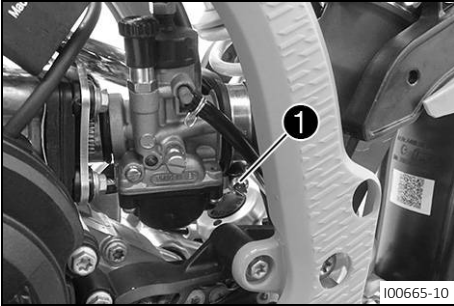

- Remove screws ② on the right and left side.
- Remove subframe with air filter box.

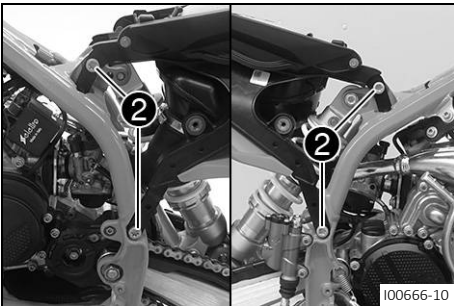

- Loosen hose clip ③ and slide the intake snorkel to the desired position.

Guideline

High seat position	Position A
Low seat position	Position B

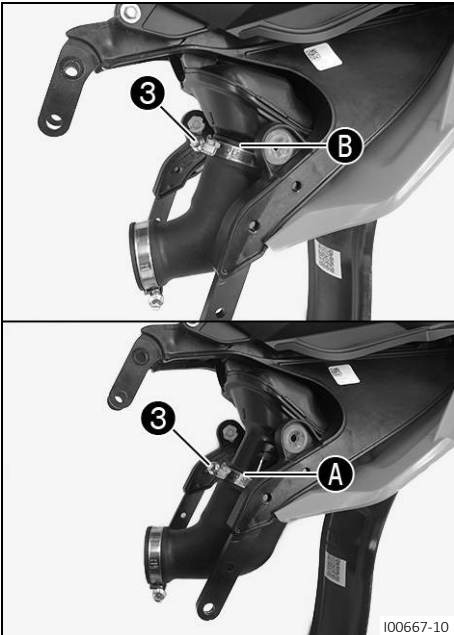

11 SEAT HEIGHT

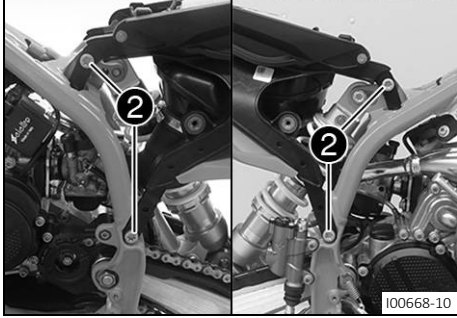
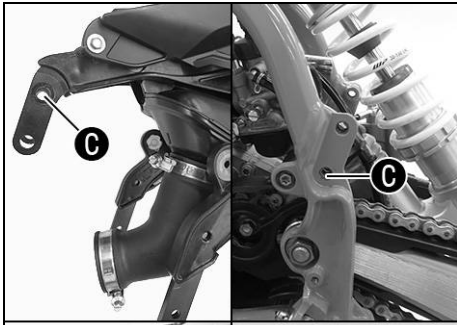

Condition

Low seat position

- Position subframe in position **C** with screws **2** on the right and left side and tighten.

Guideline

Screw, tail assembly	M8	30 Nm (22.1 lbf ft) Loctite®2701™
----------------------	----	---

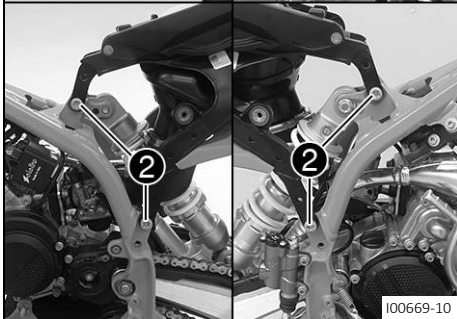
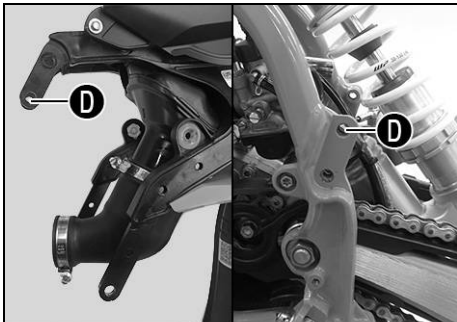

Condition

High seat position

- Position subframe in position **D** with screws **2** on the right and left side and tighten.

Guideline

Screw, tail assembly	M8	30 Nm (22.1 lbf ft) Loctite®2701™
----------------------	----	---

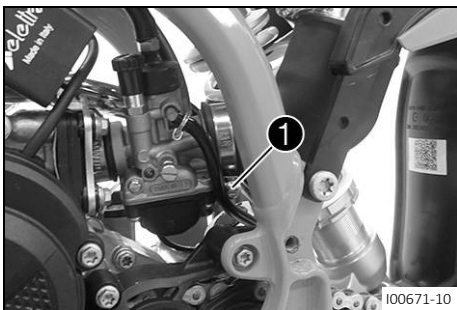

- Position the intake flange on the carburetor and tighten hose clip **1**.

Guideline

Hose clip, carburetor	-	2.8 Nm (2.07 lbf ft)
-----------------------	---	----------------------

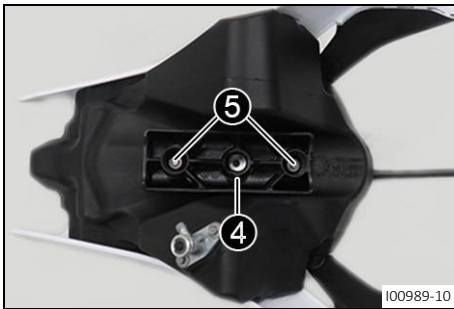
**Condition**

Low seat position

- Make sure that tank extension 4 is removed.

Condition

High seat position

- Make sure that tank extension 4 is fitted to the fuel tank using screws 5 supplied.

Guideline

Tank extension screw	EJOT	2 Nm (1.5 lbf ft)
----------------------	-------------	-------------------

- Install the fuel tank. (🔧📖 p. 51)
- Attach the throttle cable wire to the top tube in the area A with a cable tie.

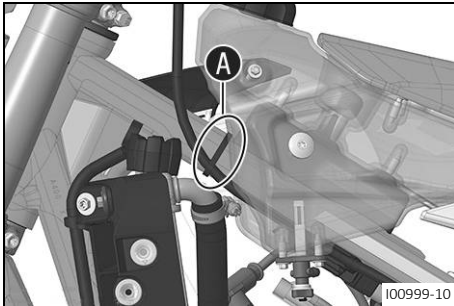
**Finishing work**

- Install the main silencer. (🔧📖 p. 61)
- Install the fuel tank. (🔧📖 p. 51)
- Mount the seat. (🔧📖 p. 57)



12.1 Raising the motorcycle with a lift stand

Note

Material damage The vehicle may be damaged by incorrect procedure when parking.

Significant damage may be caused if the vehicle rolls away or falls over.

The components for parking the vehicle are designed only for the weight of the vehicle.

- Park the vehicle on a firm and level surface.
- Ensure that nobody sits on the vehicle when the vehicle is parked on a stand.

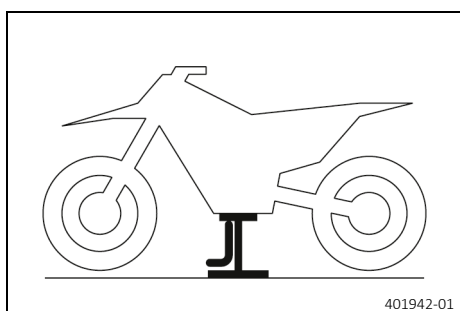

- Raise the motorcycle at the frame underneath the engine.
 - ✓ Neither wheel is in contact with the ground.
- Secure the motorcycle against falling over.

12.2 Removing the motorcycle from the lift stand

Note

Material damage The vehicle may be damaged by incorrect procedure when parking.

Significant damage may be caused if the vehicle rolls away or falls over.

The components for parking the vehicle are designed only for the weight of the vehicle.

- Park the vehicle on a firm and level surface.
- Ensure that nobody sits on the vehicle when the vehicle is parked on a stand.

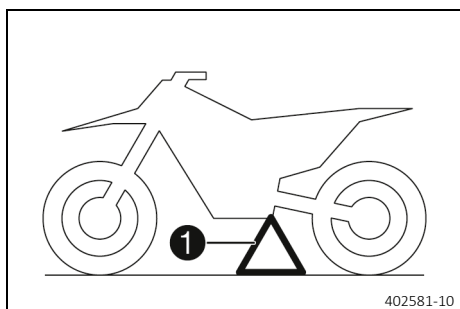

- Remove the motorcycle from the lift stand.
- Remove the lift stand.
- To park the motorcycle, insert plug-in stand ① into the plug-in stand bracket on the left side of the vehicle.



Info

Remove the plug-in stand before riding.

12.3 Bleeding the fork legs

Preparatory work

- Raise the motorcycle with a lift stand. (📖 p. 42)

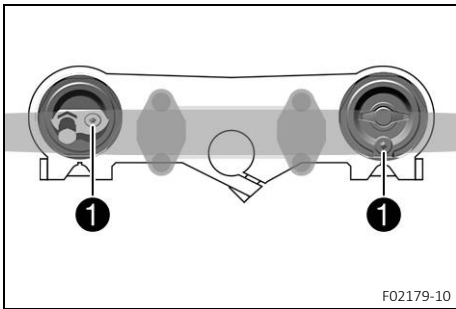

Main work

- Release bleeder screws ①.
- ✓ Any excess pressure escapes from the interior of the fork.
- Tighten the bleeder screws.

Finishing work

- Remove the motorcycle from the lift stand. (📖 p. 42)



12.4 Cleaning the dust boots of the fork legs

Preparatory work

- Raise the motorcycle with a lift stand. (📖 p. 42)
- Remove the fork protector. (📖 p. 44)

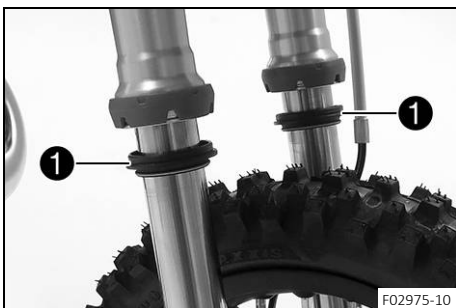

Main work

- Push dust boots ① of both fork legs downward.



Info

The dust boots remove dust and coarse dirt particles from the inside fork tubes. Over time, dirt can accumulate behind the dust boots. If this dirt is not removed, the seals rings behind can start to leak.



Warning

Danger of accidents Oil or grease on the brake discs reduces the braking effect.

- Always keep the brake discs free of oil and grease.
- Clean the brake discs with brake cleaner when necessary.

- Clean and oil the dust boots and inside fork tubes of both fork legs.

Universal oil spray (📖 p. 125)

- Press the dust boots back into the installation position.
- Remove the excess oil.

Finishing work

- Install the fork protector. (📖 p. 44)
- Remove the motorcycle from the lift stand. (📖 p. 42)



12.5 Removing the fork protector

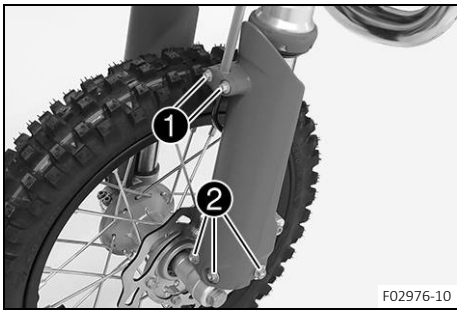

- Remove screws **1** and take off the clamp.
- Remove screws **2** on the left fork leg. Take off the fork protector.

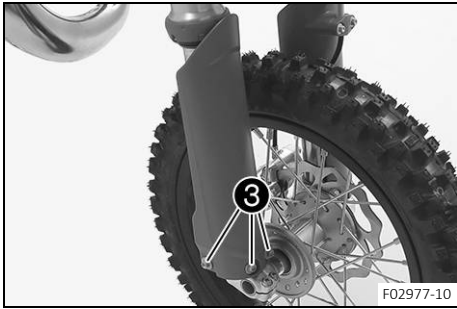

- Remove screws **3** on the right fork leg. Take off the fork protector.

12.6 Installing the fork protector

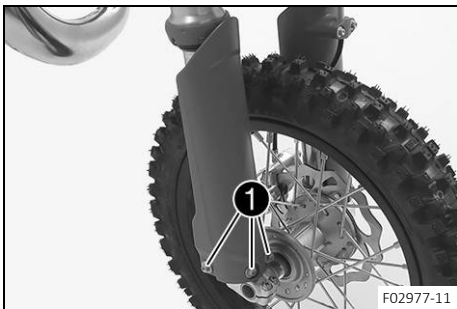

- Position fork protector on the right fork leg. Mount and tighten screws **1**.

Guideline

Remaining screws, chassis	M6	10 Nm (7.4 lbf ft)
---------------------------	----	--------------------



- Position fork protector on left fork leg. Mount and tighten screws **2**.

Guideline

Remaining screws, chassis	M6	10 Nm (7.4 lbf ft)
---------------------------	----	--------------------

- Position the brake line and the clamp. Mount and tighten screws **3**.

Guideline

Screw, brake hose bracket	EJOT PT K60x20-Z	2 Nm (1.5 lbf ft)
---------------------------	----------------------------	-------------------

12.7 Removing the fork legs

Preparatory work

- Raise the motorcycle with a lift stand. (🔧 p. 42)
- Remove the front wheel. (🔧 p. 83)

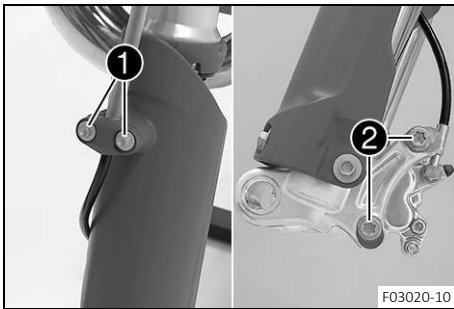

Main work

- Remove screws ① and take off the clamp.
- Remove screws ② and take off the brake caliper.
- Allow the brake caliper and the brake line to hang loosely to the side.

i Info
Do not kink the brake line.

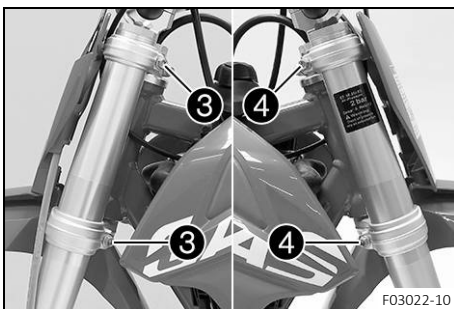

- Loosen screws ③. Remove the left fork leg.
- Loosen screws ④. Remove the right fork leg.

12.8 Installing the fork legs

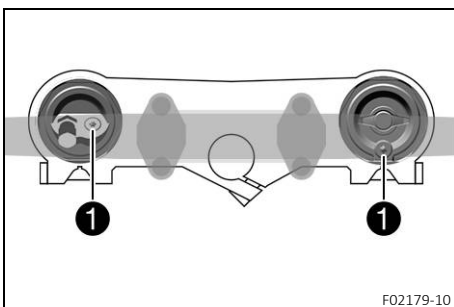

Main work

- Position the fork legs.
- ✓ Bleeder screws ① are positioned toward the rear.

i Info
The second milled groove in the fork leg must be flush with the upper edge of the upper triple clamp.

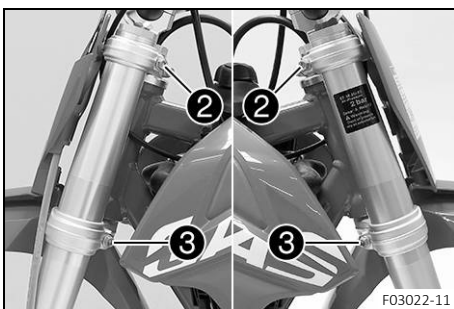

- Tighten screws ②.

Guideline

Screw, top triple clamp	M8	20 Nm (14.8 lbf ft)
-------------------------	----	---------------------

- Tighten screws ③.

Guideline

Screw, bottom triple clamp	M8	15 Nm (11.1 lbf ft)
----------------------------	----	---------------------

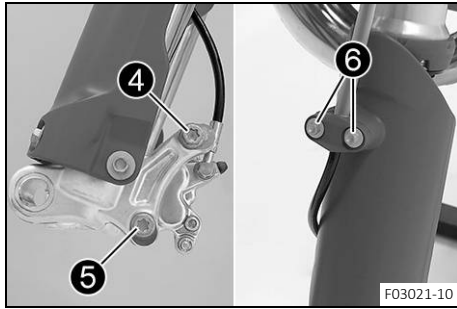

- Position the brake caliper, mount screw ④, and tighten.

Guideline

Screw, front brake caliper	M8x60	20 Nm (14.8 lbf ft) Loctite®243™
----------------------------	-------	--

- Mount and tighten screw ⑤.

Guideline

Screw, front brake caliper	M8x40	20 Nm (14.8 lbf ft) Loctite®243™
----------------------------	-------	--

- Position the brake line and the clamp. Mount and tighten screws ⑥.

Guideline

Screw, brake hose bracket	EJOT PT K60x20-Z	2 Nm (1.5 lbf ft)
---------------------------	----------------------------	-------------------

Finishing work

- Install the front wheel. 🛠️ (📖 p. 83)

12.9 Removing the lower triple clamp 🛠️

Preparatory work

- Raise the motorcycle with a lift stand. (📖 p. 42)
- Remove the front wheel. 🛠️ (📖 p. 83)
- Remove the fork legs. 🛠️ (📖 p. 45)
- Remove the start number plate. (📖 p. 53)
- Remove front fender. (📖 p. 53)

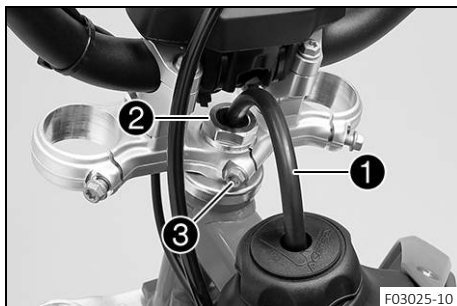

Main work

- Pull fuel tank breather ① out of the steering stem.
- Remove nut ②.
- Release screw ③, take off the upper triple clamp with the handlebar and set aside.

Info

Cover the components to protect them against damage.
Do not kink the cables and lines.

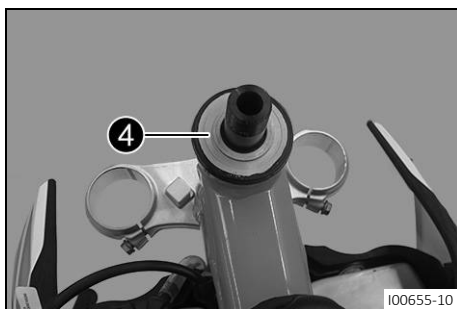

- Remove protective ring ④.
- Remove the lower triple clamp with the steering stem.
- Remove the upper steering head bearing.

12.10 Installing the lower triple clamp ↗

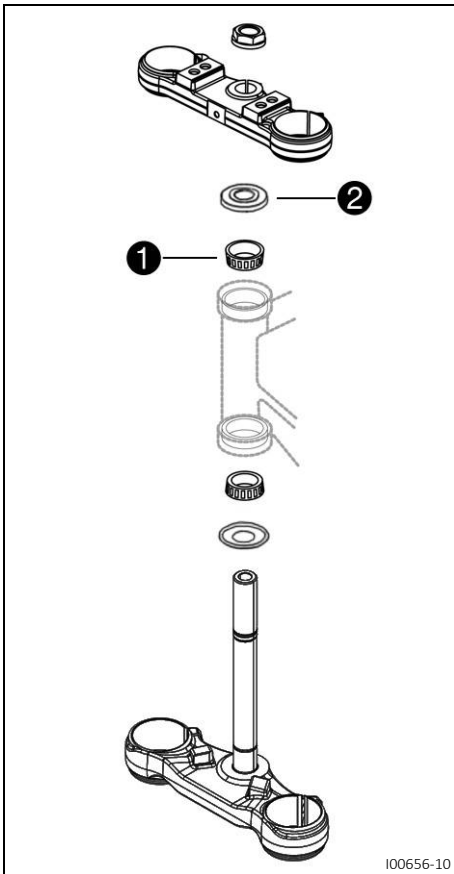

Main work

- Clean the bearing and sealing elements, check for damage, and grease.

High viscosity grease (🔧 p. 124)

- Insert the lower triple clamp with the steering stem. Mount upper steering head bearing ①.
- Push on protective ring ②.

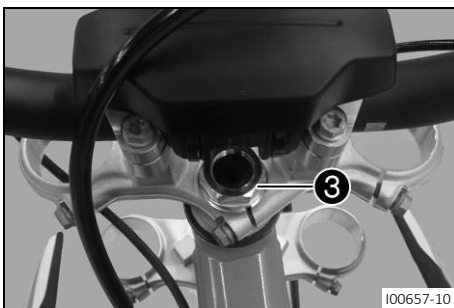

- Position the upper triple clamp and handlebar.
- Mount nut ③, but do not tighten yet.

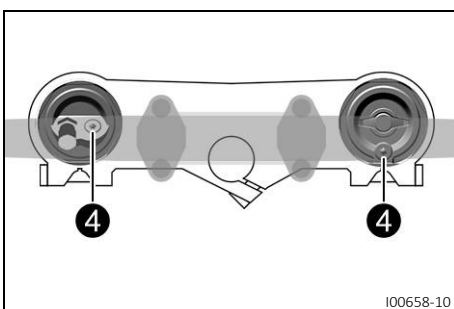

- Position the fork legs.
- ✓ Bleeder screws ④ are positioned toward the rear.

i Info
The upper milled groove in the fork leg must be flush with the upper edge of the upper triple clamp.

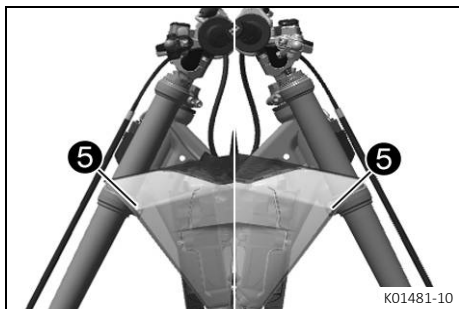

- Tighten screws **5**.

Guideline

Screw, bottom triple clamp	M8	15 Nm (11.1 lbf ft)
----------------------------	----	---------------------

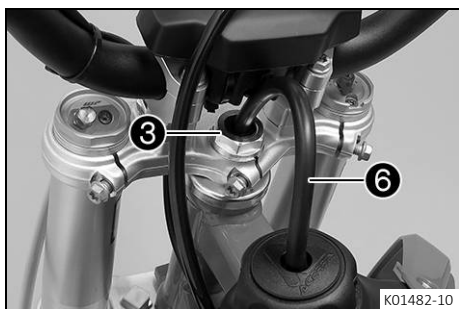

- Tighten nut **3**.

Guideline

Nut, steering head	M20x1.5	10 Nm (7.4 lbf ft)
--------------------	---------	--------------------

- Position the fuel tank breather **6** in the steering stem.



- Tighten bolt **7**.

Guideline

Screw, top triple clamp	M8	20 Nm (14.8 lbf ft)
-------------------------	----	---------------------

- Using a plastic hammer, tap lightly on the upper triple clamp to avoid stresses.

- Tighten screws **8**.

Guideline

Screw, top triple clamp	M8	20 Nm (14.8 lbf ft)
-------------------------	----	---------------------

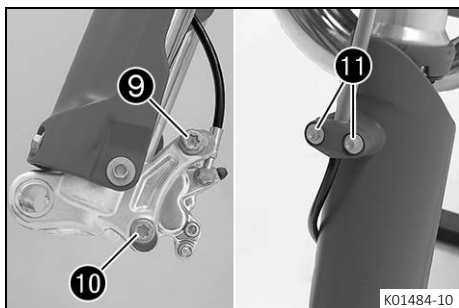

- Position the brake caliper, mount screw **9**, and tighten.

Guideline

Screw, front brake caliper	M8x60	20 Nm (14.8 lbf ft) Loctite®243™
----------------------------	-------	--

- Mount and tighten screw **10**.

Guideline

Screw, front brake caliper	M8x40	20 Nm (14.8 lbf ft) Loctite®243™
----------------------------	-------	--

- Position the brake line and the clamp. Mount and tighten screws **11**.

Guideline

Screw, brake hose bracket	EJOT PT K60x20-Z	2 Nm (1.5 lbf ft)
---------------------------	----------------------------	-------------------

Finishing work

- Check that the wiring harness, cables, brake line have the necessary freedom of movement and are correctly routed.
- Install the front fender. (📖 p. 54)
- Install the start number plate. (📖 p. 53)
- Check the wiring harness, cables, and brake and clutch lines for freedom of movement and correct routing.
- Install the front wheel. 🛠️ (📖 p. 83)
- Check the steering head bearing play. (📖 p. 49)

- Remove the motorcycle from the lift stand. (📖 p. 42)



12.11 Checking the steering head bearing play



Warning

Danger of accidents Incorrect steering head bearing play impairs the handling characteristic and damages components.

- Correct incorrect steering head bearing play immediately. (Your authorized GASGAS Motorcycles workshop will be glad to help.)



Info

If the vehicle is operated for a lengthy period with play in the steering head bearing, the bearings and the bearing seats in the frame can become damaged over time.

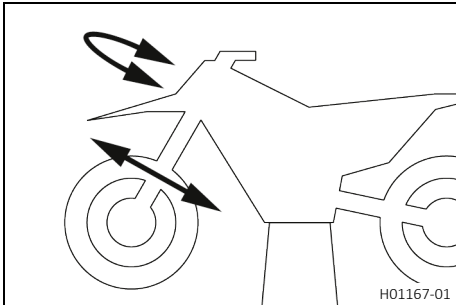

Preparatory work

- Raise the motorcycle with a lift stand. (📖 p. 42)

Main work

- Move the handlebar to the straight-ahead position. Move the fork legs to and fro in the direction of travel.

Play should not be detectable on the steering head bearing.

- » If there is detectable play:
 - Adjust the steering head bearing play. (🔧📖 p. 49)

- Move the handlebar to and fro over the entire steering range.

It must be possible to move the handlebar easily over the entire steering range. There should be no detectable detent positions.

- » If detent positions are detected:
 - Adjust the steering head bearing play. (🔧📖 p. 49)
 - Check the steering head bearing and replace if required.

Finishing work

- Remove the motorcycle from the lift stand. (📖 p. 42)



12.12 Adjusting the steering head bearing play 🔧



Preparatory work

- Raise the motorcycle with a lift stand. (📖 p. 42)

Main work

- Pull fuel tank breather ① out of the steering stem.
- Loosen screws ②.
- Loosen screw ③.
- Loosen and retighten nut ④.

Guideline

Nut, steering head	M20x1.5	10 Nm (7.4 lbf ft)
--------------------	---------	--------------------

- Using a plastic hammer, tap lightly on the upper triple clamp to avoid stresses.

- Tighten screw ③.

Guideline

Screw, steering stem	M8	20 Nm (14.8 lbf ft)
----------------------	----	---------------------

- Tighten screws ②.

Guideline

Screw, top triple clamp	M8	20 Nm (14.8 lbf ft)
-------------------------	----	---------------------

- Position the fuel tank breather ① in the steering stem.

Finishing work

- Check the steering head bearing play. (📖 p. 49)
- Remove the motorcycle from the lift stand. (📖 p. 42)

12.13 Lubricating the steering head bearing 🛠️

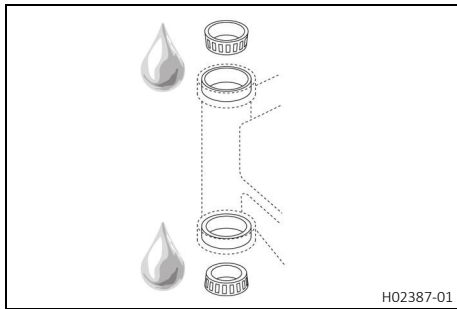

- Remove the lower triple clamp. 🛠️ (📖 p. 46)
- Install the lower triple clamp. 🛠️ (📖 p. 47)



Info

The steering head bearing is cleaned and lubricated in the course of removal and installation of the lower triple clamp.

12.14 Removing the fuel tank 🛠️



Danger

Fire hazard Fuel is highly flammable.

The fuel in the fuel tank expands when warm and can escape if overfilled.

- Do not fuel the vehicle in the vicinity of open flames or lit cigarettes.
- Switch off the engine for refueling.
- Make sure that no fuel is spilled; particularly not on hot parts of the vehicle.
- If any fuel is spilled, wipe it off immediately.
- Observe the specifications for refueling.



Warning

Danger of poisoning Fuel is harmful to health.

- Avoid skin, eye and clothing contact with fuel.
- Immediately consult a doctor if you swallow fuel.
- Do not inhale fuel vapors.
- Rinse the affected area immediately with plenty of water in the event of contact with the skin.
- Rinse the eyes thoroughly with water, and consult a doctor in case of fuel contact with the eyes.
- Change your clothing if fuel spills on them.
- Keep fuels correctly in a suitable canister, and out of the reach of children.

Preparatory work

- Remove the seat. (📖 p. 57)
- Turn the knurled screw on the fuel tap all the way clockwise.

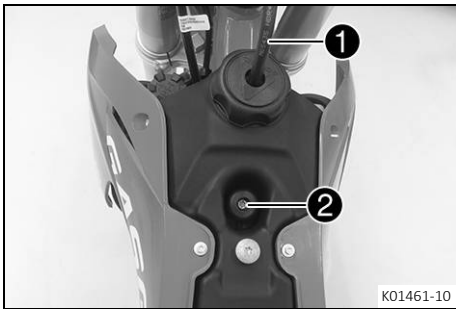

Main work

- Pull fuel tank breather **1** out of the steering stem.
- Remove screw **2**.

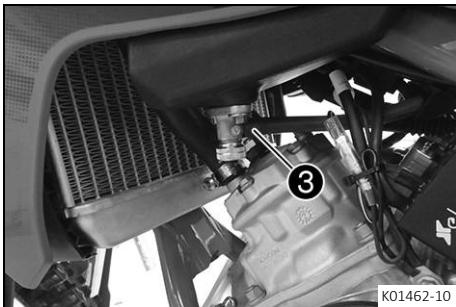

- Pull off fuel hose **3**.



Info

Remaining fuel may flow out of the fuel hose.

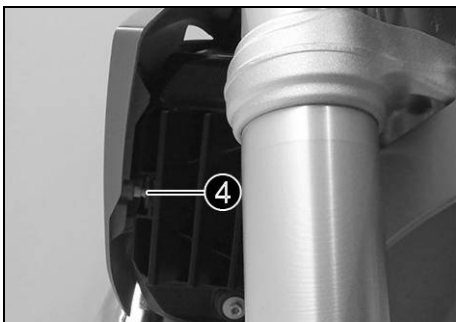

- Pull the fuel tank guard out of rubber bushing **4**.
- Raise the fuel tank.
- Take off the fuel tank.

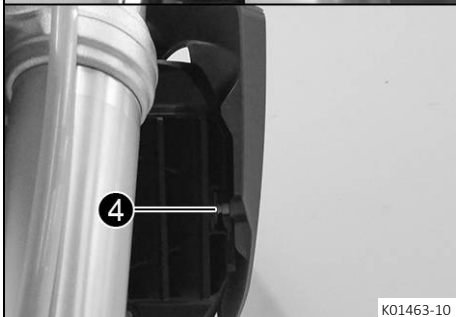

12.15 Installing the fuel tank ↩



Danger

Fire hazard Fuel is highly flammable.

The fuel in the fuel tank expands when warm and can escape if overfilled.

- Do not fuel the vehicle in the vicinity of open flames or lit cigarettes.
- Switch off the engine for refueling.
- Make sure that no fuel is spilled; particularly not on hot parts of the vehicle.
- If any fuel is spilled, wipe it off immediately.
- Observe the specifications for refueling.



Warning

Danger of poisoning Fuel is harmful to health.

- Avoid skin, eye and clothing contact with fuel.
- Immediately consult a doctor if you swallow fuel.
- Do not inhale fuel vapors.
- Rinse the affected area immediately with plenty of water in the event of contact with the skin.
- Rinse the eyes thoroughly with water, and consult a doctor in case of fuel contact with the eyes.
- Change your clothing if fuel spills on them.
- Keep fuels correctly in a suitable canister, and out of the reach of children.

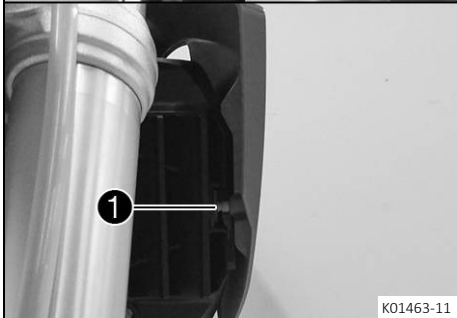
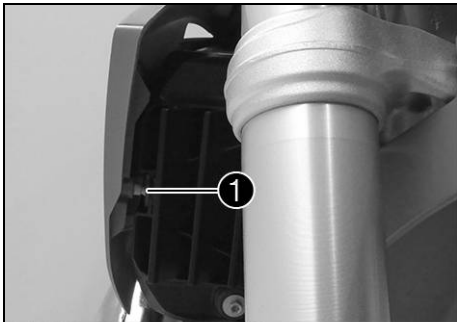

K01463-11

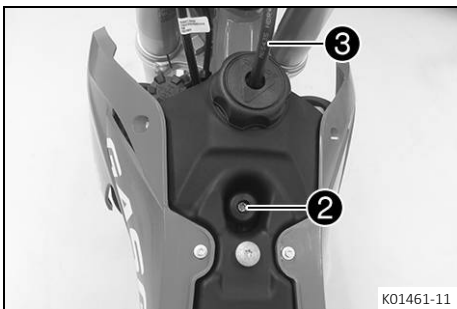

K01461-11



K01462-11

Main work

- Position the fuel tank.
- Make sure that no cables or throttle cables are trapped or damaged.
- Press fuel tank guard into rubber bushing **1**.
- Check the throttle cable routing. (📖 p. 67)

- Mount and tighten screw **2**.

Guideline

Remaining screws, chassis	M6	10 Nm (7.4 lbf ft)
---------------------------	----	--------------------

- Position the fuel tank breather **3** in the steering stem.

- Mount fuel hose **4**.
- Turn the knurled screw on the fuel tap all the way counterclockwise.

Finishing work

- Mount the seat. (📖 p. 57)

12.16 Removing the start number plate

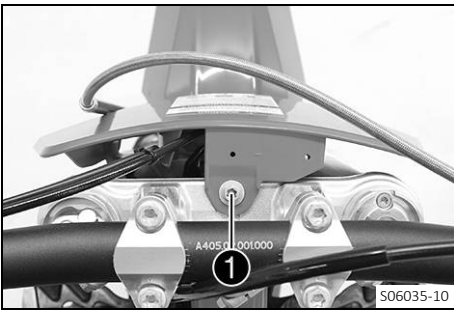

- Remove the service hour counter and hang it to one side.
- Remove screw ①.
- Unhook the start number plate from the brake line and remove it.



12.17 Installing the start number plate



- Attach the start number plate to the brake line.
- Position the start number plate.
- ✓ Holding lugs ① engage in the fender.

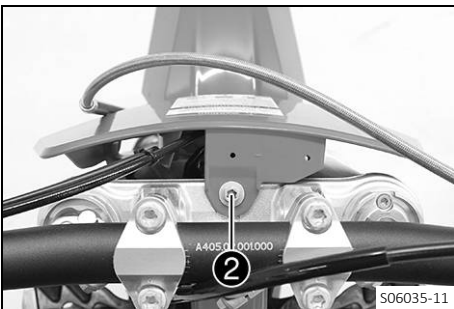

- Mount and tighten screw ②.

Guideline

Screw, start number plate	M6	4 Nm (3 lbf ft)
---------------------------	----	-----------------

- Install service hour counter.



12.18 Removing front fender

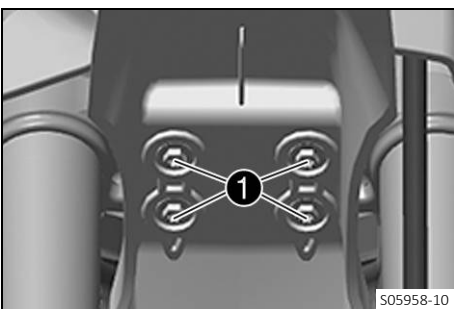

- Remove screws ①. Take off the front fender.



12.19 Installing the front fender

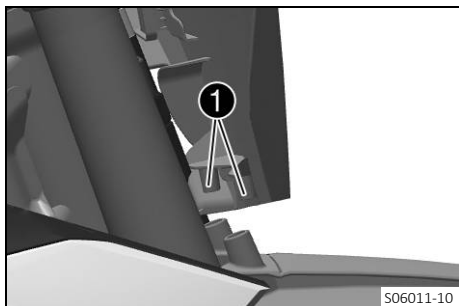

- Position start number plate on the fender.
- ✓ The holding lugs of the start number plate engage in drill holes **1** of the fender.

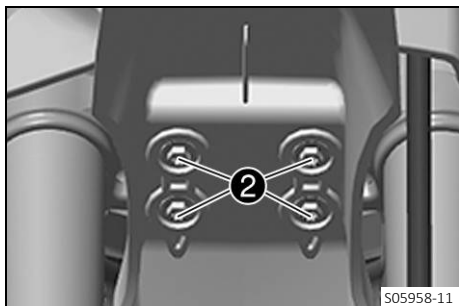

- Position fender on the lower triple clamp, mount and tighten screws **2**.

Guideline

Screw, fender	M6	6 Nm (4.4 lbf ft)
---------------	----	-------------------

12.20 Removing the left side cover

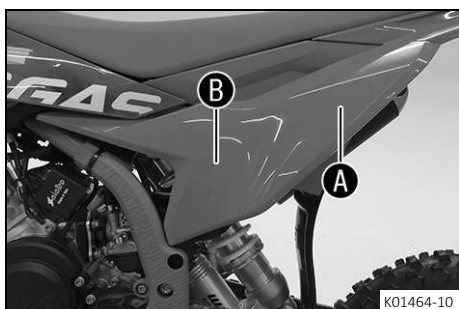

- Remove left side cover from the rubber bushings in the areas **A** and **B**.
- Take off the left side cover.

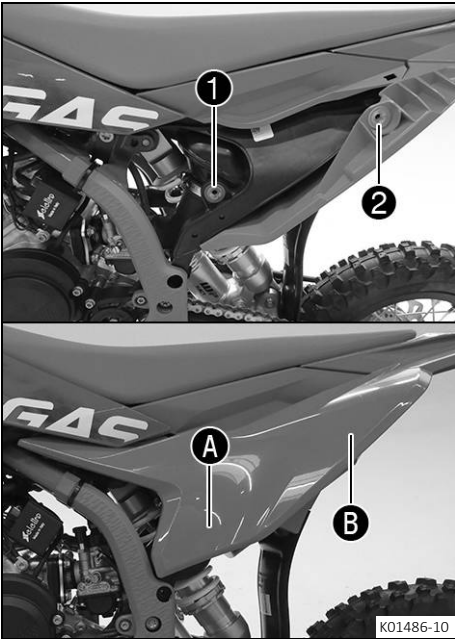
12.21 Installing the left side cover

- Press the left side cover in area **A** into rubber bushing **1** and press into rubber bushing **B** in area **2**.

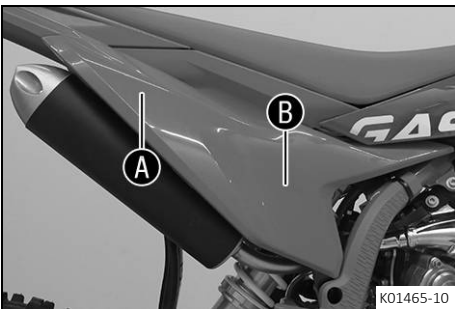
**12.22 Removing the right side cover**

- Remove the side cover from the rubber bushings in areas **A** and **B**.
- Remove the right side cover.



12.23 Installing the right side cover

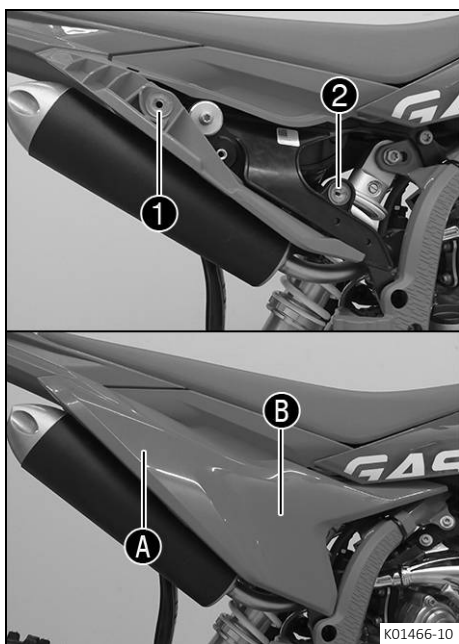

- Press the right side cover in the area **A** into rubber bushing **1** and press into rubber bushing **B** in area **2**.

12.24 Removing the shock absorber

Preparatory work

- Raise the motorcycle with a lift stand. (📖 p. 42)
- Remove the right side cover. (📖 p. 55)

Main work

- Pull brake line **1** out of the holder.
- Remove screw **2** and lower the link fork carefully.
- Remove screw **3**, push splash protector **4** to the side, and remove the shock absorber.

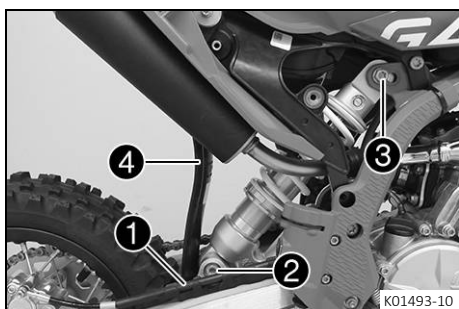

12.25 Installing the shock absorber



Warning

Danger of accidents Modifications to the suspension setting may seriously alter the handling characteristic.

- Make sure your child rides slowly to start with after making adjustments in order that he or she can assess the new handling characteristic.

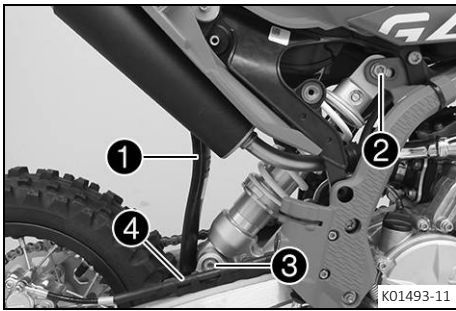

Main work

- Push splash protector ① to the side.
- Position the shock absorber with screw ②, depending on the desired seating height.
- Raise the link fork, mount and tighten the shock absorber with screw ③.

Guideline

Screw, bottom shock absorber	M10	45 Nm (33.2 lbf ft) Loctite®243™
------------------------------	-----	--

- Tighten screw ②.

Guideline

Screw, top shock absorber	M10	45 Nm (33.2 lbf ft) Loctite®243™
---------------------------	-----	--

- Attach brake line ④ to the holder.

Finishing work

- Install the right side cover. (📖 p. 56)
- Remove the motorcycle from the lift stand. (📖 p. 42)



12.26 Removing the seat

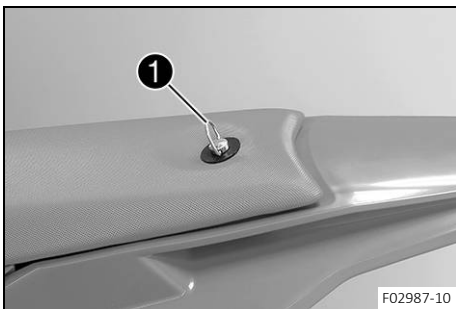

- Open quick release ① and raise the rear of the seat.
- Pull back the seat and remove it.



12.27 Mounting the seat



- Hook seat onto screw ① and lower the seat at the rear and push it forward.
- ✓ Holding lug ② hooks into the fuel tank.

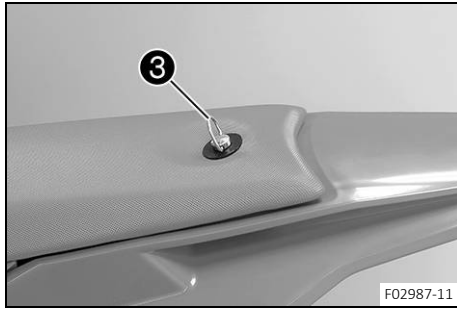

- Close quick release **3**.

12.28 Removing the frame protector

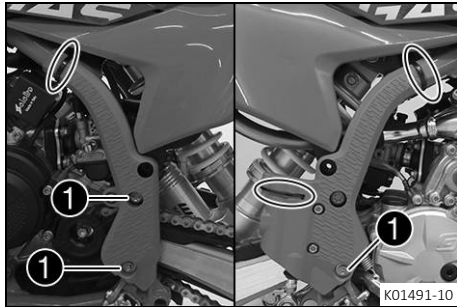

- Remove the cable ties.
- Remove screws **1** with the bushings.
- Take off the left frame protector.
- Push the right frame protector to the front and take off at the bottom.

12.29 Installing the frame protector

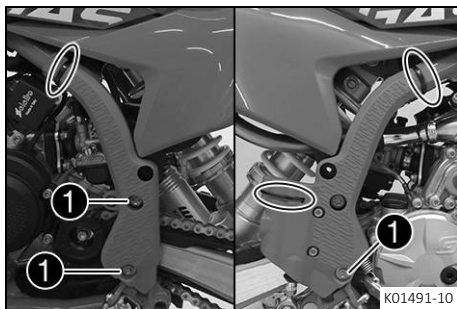

- Position the left frame protector.
- Insert the right frame protector from below and push it to the rear.
- Mount screws **1** with the bushings and tighten.

Guideline

Remaining screws, chassis	M5	5 Nm (3.7 lbf ft)
---------------------------	----	-------------------

- Secure the frame protector with cable ties.

12.30 Removing the air filter

Note

Engine damage Unfiltered intake air has a negative effect on the service life of the engine.

Dust and dirt will enter the engine without an air filter.

- Only operate the vehicle if it is equipped with an air filter.



Note

Environmental hazard Hazardous substances cause environmental damage.



- Dispose of oils, grease, filters, fuel, cleaning agents, brake fluid, etc., correctly and in compliance with the applicable regulations.

Preparatory work

- Remove the seat. (📖 p. 57)

**Main work**

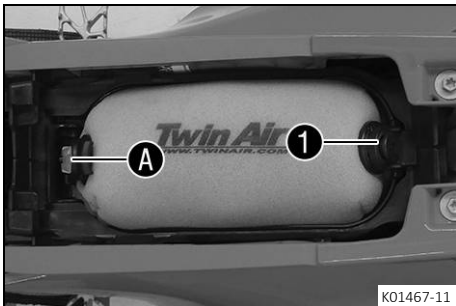
- Detach retaining tab ①. Remove the air filter to the front.

**12.31 Installing the air filter** **Main work**

- Insert a clean air filter in area A.
- Secure air filter with retaining pin ①.

**Info**

If the air filter is not mounted correctly, dust and dirt may enter the engine and result in damage.

Finishing work

- Mount the seat. (📖 p. 57)

**12.32 Cleaning the air filter and air filter box** **Note**

Environmental hazard Hazardous substances cause environmental damage.

- Dispose of oils, grease, filters, fuel, cleaning agents, brake fluid, etc., correctly and in compliance with the applicable regulations.

**Info**

Do not clean the air filter with fuel or petroleum since these substances attack the foam.

Preparatory work

- Remove the seat. (📖 p. 57)
- Remove the air filter.  (📖 p. 58)

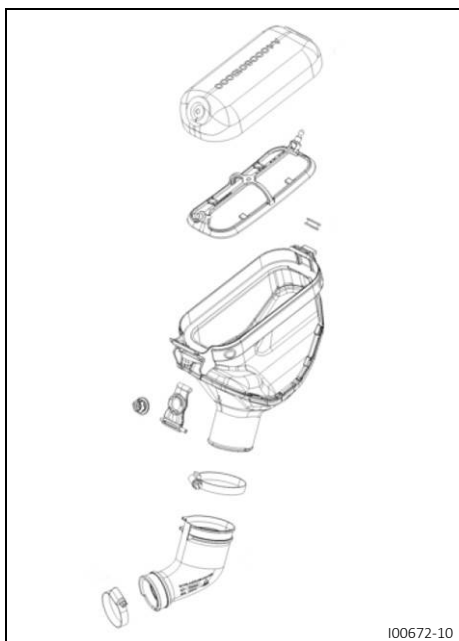

Main work

- Wash the air filter thoroughly in special cleaning liquid and allow it to dry properly.

Air filter cleaner (📖 p. 124)

Info

Only press the air filter to dry it, never wring it out.

- Oil the dry air filter with a high-grade air filter oil.

Oil for foam air filter (📖 p. 124)

- Clean the air filter box.
- Check intake flange for damage and looseness.

Finishing work

- Install the air filter. (📖 p. 59)
- Mount the seat. (📖 p. 57)

12.33 Removing the main silencer



Warning

Danger of burns The exhaust system gets hot when the vehicle is driven.

- Allow the exhaust system to cool down before performing any work on the vehicle.



Preparatory work

- Remove the right side cover. (📖 p. 55)

Main work

- Remove screw ①.
- Pull off the main silencer from the manifold at sleeve ②.

12.34 Installing the main silencer

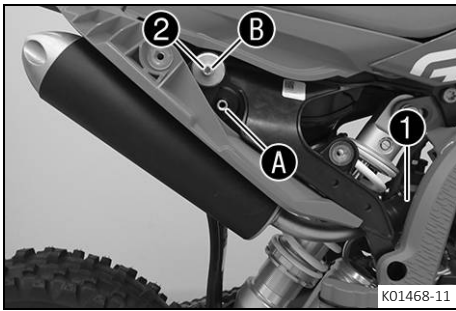

- Position the main silencer.
- Mount the main silencer with sleeve 1.

Guideline

High seat position	A
Low seat position	B

- Mount and tighten screw 2.

Guideline

Remaining screws, chassis	M6	10 Nm (7.4 lbf ft)
---------------------------	----	--------------------



12.35 Changing the rock wool on the main silencer



Warning

Danger of burns The exhaust system gets hot when the vehicle is driven.

- Allow the exhaust system to cool down before performing any work on the vehicle.



Info

Over time, the rock wool fibers disappear, and the main silencer “burns out”. Not only is the noise level higher, but the performance characteristics change.

Preparatory work

- Remove the right side cover. (📖 p. 55)
- Remove main silencer. (📖 p. 60)

Main work

- Remove screws with toothed washers 1 from the silencer cap 2.
- Remove end cap and outer tube 3.
- Remove rock wool 4 from the inner tube.
- Clean the parts that need to be reinstalled and check for damage.
- Fit new rock wool on the inner tube.
- Slide outer tube over the rock wool.
- Insert the silencer cap into the outer tube.
- Mount and tighten the screws with the toothed washers.

Guideline

Remaining screws, chassis	M6	10 Nm (7.4 lbf ft)
---------------------------	----	--------------------

Finishing work

- Install the main silencer. (📖 p. 61)

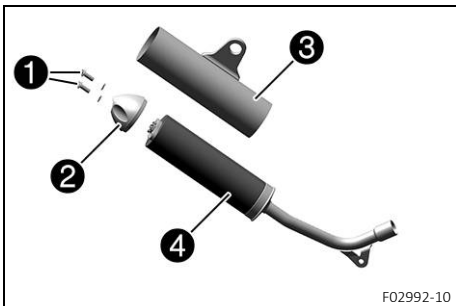

12.36 Removing the engine sprocket cover

Preparatory work

- Raise the motorcycle with a lift stand. (📖 p. 42)

Main work

- Remove screws ①.
- Remove screw ②.
- Take off the engine sprocket cover.

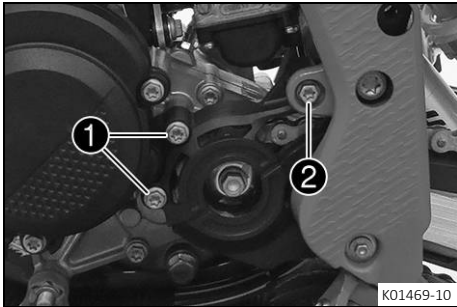

K01469-10

12.37 Installing the engine sprocket cover

Main work

- Position the engine sprocket cover. Mount screws ①, but do not tighten yet.
- Mount and tighten screw ②.

Guideline

Screw, rear engine sprocket cover	M6x12	8 Nm (5.9 lbf ft)
-----------------------------------	-------	-------------------

- Tighten screws ①.

Guideline

Screw, rear engine sprocket cover	M6x12	8 Nm (5.9 lbf ft)
-----------------------------------	-------	-------------------

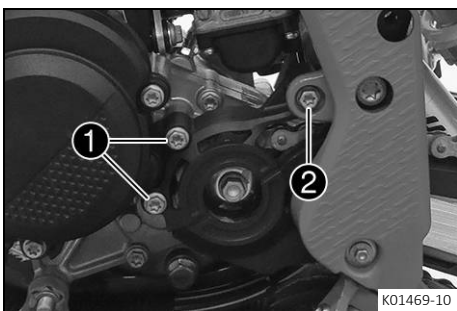

K01469-10

Finishing work

- Remove the motorcycle from the lift stand. (📖 p. 42)

12.38 Checking the chain for dirt

- Check the chain for coarse dirt accumulation.
 - » If the chain is very dirty:
 - Clean the chain. (📖 p. 63)

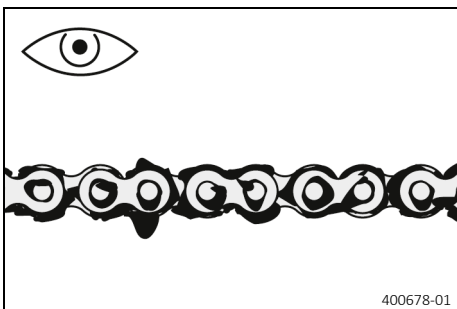

400678-01

12.39 Cleaning the chain



Warning

- Danger of accidents** Lubricants on the tires reduces the road grip.
- Remove lubricants from the tires using a suitable cleaning agent.



Warning

- Danger of accidents** Oil or grease on the brake discs reduces the braking effect.
- Always keep the brake discs free of oil and grease.
 - Clean the brake discs with brake cleaner when necessary.



Note

- Environmental hazard** Hazardous substances cause environmental damage.
- Dispose of oils, grease, filters, fuel, cleaning agents, brake fluid, etc., correctly and in compliance with the applicable regulations.



Info

The service life of the chain depends largely on its maintenance.

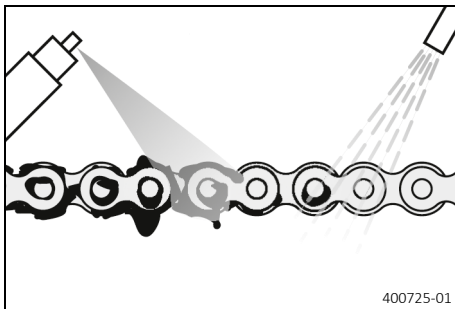

Preparatory work

- Raise the motorcycle with a lift stand. (📖 p. 42)

Main work

- Rinse off loose dirt with a soft jet of water.
- Remove old grease residue with chain cleaner.

Chain cleaner (📖 p. 124)

- After drying, apply chain spray.

Off-road chain spray (📖 p. 124)

Finishing work

- Remove the motorcycle from the lift stand. (📖 p. 42)



12.40 Checking the chain tension



Warning

Danger of accidents Incorrect chain tension damages components and results in accidents.

If the chain is tensioned too much, the chain, engine sprocket, rear sprocket, transmission and rear wheel bearings wear more quickly. Some components may break if overloaded.

If the chain is too loose, the chain may fall off the engine sprocket or the rear sprocket. As a result, the rear wheel locks or the engine will be damaged.

- Check the chain tension regularly.
- Set the chain tension in accordance with the specification.

Preparatory work

- Raise the motorcycle with a lift stand. (📖 p. 42)

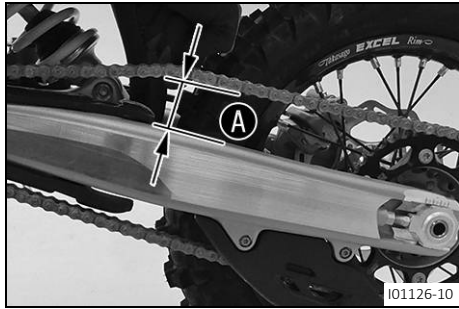

Main work

- Press the chain upward at the end of the chain sliding piece and determine chain tension **A**.



Info

Chain wear is not always even, so repeat this measurement at different positions on the chain.

Chain tension	35 ... 38 mm (1.38 ... 1.5 in)
---------------	--------------------------------

- » If the chain tension does not meet the specification:
 - Adjust the chain tension. (📖 p. 64)

Finishing work

- Remove the motorcycle from the lift stand. (📖 p. 42)

12.41 Adjusting the chain tension



Warning

Danger of accidents Incorrect chain tension damages components and results in accidents.

If the chain is tensioned too much, the chain, engine sprocket, rear sprocket, transmission and rear wheel bearings wear more quickly. Some components may break if overloaded.

If the chain is too loose, the chain may fall off the engine sprocket or the rear sprocket. As a result, the rear wheel locks or the engine will be damaged.

- Check the chain tension regularly.
- Set the chain tension in accordance with the specification.

Preparatory work

- Raise the motorcycle with a lift stand. (📖 p. 42)
- Check the chain tension. (📖 p. 63)

Main work

- Loosen nut **1**.
- Loosen nuts **2**.
- Adjust the chain tension by turning adjusting screws **3** left and right.

Guideline

Chain tension	35 ... 38 mm (1.38 ... 1.5 in)
Turn the adjusting screws 3 on the left and right so that the markings on the left and right chain adjusters 4 are in the same position relative to the reference marks A . The rear wheel is then correctly aligned.	

- Tighten nuts **2**.
- Make sure that chain adjusters **4** are fitted correctly on adjusting screws **3**.
- Tighten nut **1**.

Guideline

Rear wheel spindle nut	M12x1	70 Nm (51.6 lbf ft)
------------------------	-------	---------------------

Finishing work

- Remove the motorcycle from the lift stand. (📖 p. 42)

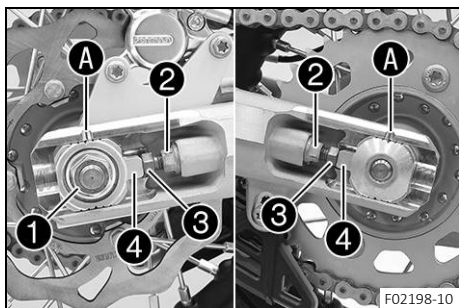

12.42 Checking the chain, rear sprocket, engine sprocket, and chain guide

Preparatory work

- Raise the motorcycle with a lift stand. (🛠️ p. 42)
- Remove the engine sprocket cover. (🛠️ p. 62)

Main work

- Check the chain, rear sprocket and engine sprocket for wear.
 - » If the chain, rear sprocket or engine sprocket is worn:
 - Change the drivetrain kit. 🛠️

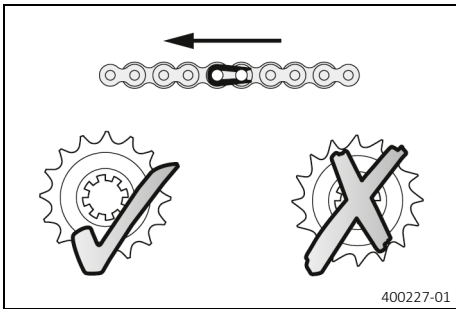

Info

The engine sprocket, rear sprocket and chain should always be replaced together.

When fitting the chain joint, always make sure that the closed side of the joint faces forward (direction of travel).



- Check the engine sprocket cover for wear.
 - » If the engine sprocket cover is worn through in the marked area **A**:
 - Change the engine sprocket cover. 🛠️
- Check the engine sprocket cover for tightness.
 - » If the engine sprocket cover is loose:
 - Tighten the engine sprocket cover.

Guideline

Screw, rear engine sprocket cover	M6x12	8 Nm (5.9 lbf ft)
-----------------------------------	-------	-------------------

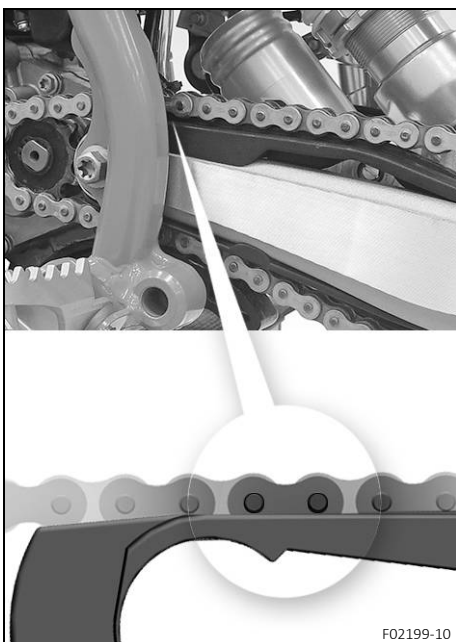

- Check the chain sliding guard for wear.
 - » If the lower edge of the chain pins is in line with, or below, the chain sliding guard:
 - Change the chain sliding guard. 🛠️
- Check that the chain sliding guard is firmly seated.
 - » If the chain sliding guard is loose:
 - Tighten the chain sliding guard.

Guideline

Remaining screws, chassis	M6	10 Nm (7.4 lbf ft)
---------------------------	----	--------------------

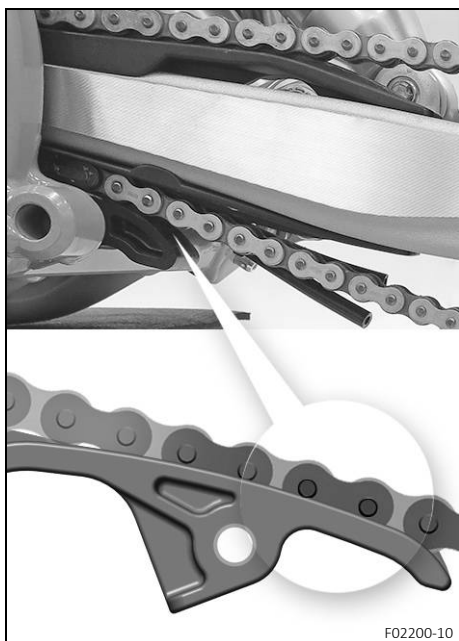

F02200-10

- Check the chain sliding piece for wear.
 - » If the lower edge of the chain pins is in line with or below the chain sliding piece:
 - Change the chain sliding piece. 🛠️
- Check that the chain sliding piece is firmly seated.
 - » If the chain sliding piece is loose:
 - Tighten the chain sliding piece.

Guideline

Screw, chain sliding piece	M8	15 Nm (11.1 lbf ft)
----------------------------	----	---------------------

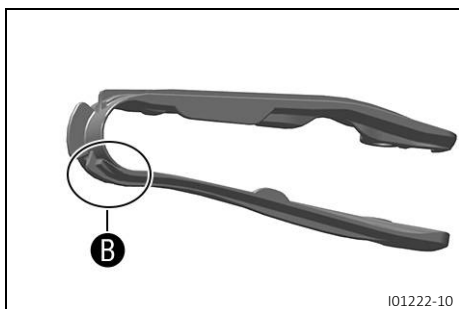

I01222-10

- Check the chain sliding piece for wear.
 - » If the chain sliding piece is worn through in the marked area **B**:
 - Change the chain sliding piece. 🛠️

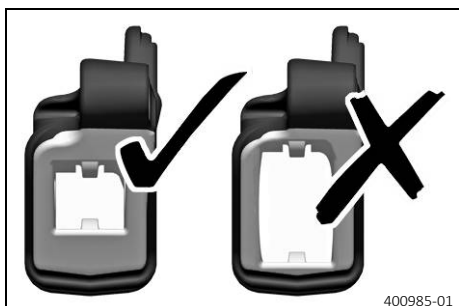

400985-01

- Check the chain guide for wear.



Info

Wear can be seen on the front of the chain guide.

- » If the light part of the chain guide is worn:
 - Change the chain guide. 🛠️



F02201-01

- Check that the chain guide is firmly seated.
 - » If the chain guide is loose:
 - Tighten the chain guide.

Guideline

Remaining screws, chassis	M6	10 Nm (7.4 lbf ft)
---------------------------	----	--------------------

Finishing work

- Install the engine sprocket cover. (📖 p. 62)
- Remove the motorcycle from the lift stand. (📖 p. 42)

12.43 Adjusting the chain guide

Info

The size of the chain wheel varies with the number of teeth. The chain guide can be adjusted on small sprockets.



- Remove screw 1.
- Position the chain guide.
- Mount and tighten screw 1.

Guideline

Remaining screws, chassis	M6	10 Nm (7.4 lbf ft)
---------------------------	----	--------------------

12.44 Checking the frame

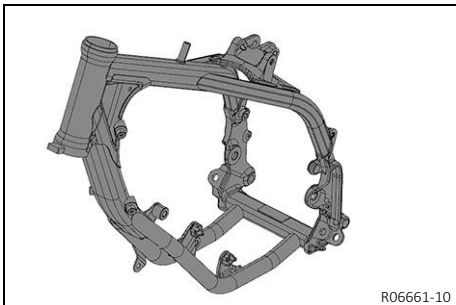

- Check the frame for damage, cracks, and deformation.
 - » If the frame shows signs of damage, cracks, or deformation:
 - Change the frame.

Guideline

Repairs on the frame are not permitted.

12.45 Checking the link fork

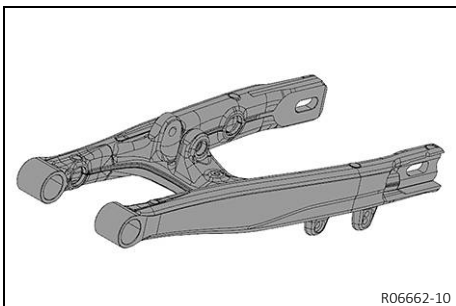

- Check the link fork for damage, cracks, and deformation.
 - » If the link fork shows signs of damage, cracks, or deformation:
 - Change the link fork.

Guideline

Repairs on the link fork are not permitted.

12.46 Checking the throttle cable routing



Warning

Danger of accidents The throttle cable can become kinked, trapped or blocked if it is not routed correctly. If the throttle cable is kinked, trapped or blocked, the speed can no longer be controlled.

- Make sure that the throttle cable routing and the play in throttle cable complies with the specification.

Preparatory work

- Remove the seat. (p. 57)
- Turn the knurled screw on the fuel tap all the way clockwise.
- Remove the fuel tank. (p. 50)



Main work

- Check the throttle cable routing.

The throttle cable must be routed to the carburetor at the rear of the handlebar, above the fuel tank bracket. It must not be hooked into the handlebar cushion.

- » If the throttle cable routing is not as specified:
 - Correct the throttle cable routing.

Finishing work

- Install the fuel tank. (🔧📖 p. 51)
- Mount the seat. (📖 p. 57)

12.47 Checking the rubber grip

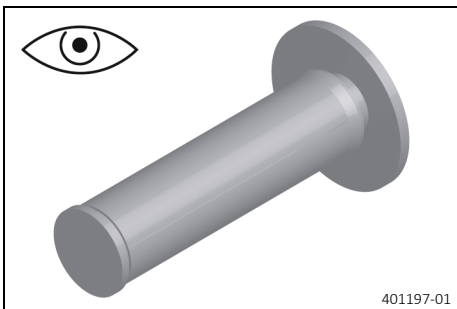

- Check the rubber grips on the handlebar for damage, wear, and looseness.



Info

The rubber grips are vulcanized onto a sleeve on the left and onto the handle tube of the throttle grip on the right. The left sleeve is clamped onto the handlebar. The rubber grip can only be replaced with the sleeve or the throttle tube.

- » If a rubber grip is damaged or worn:
 - Change the rubber grip.
- Check that screw **1** is firmly seated.

Guideline

Screw, fixed grip	M4	5 Nm (3.7 lbf ft) Loctite®243™
-------------------	----	--

Diamond **A** must be located at the top.

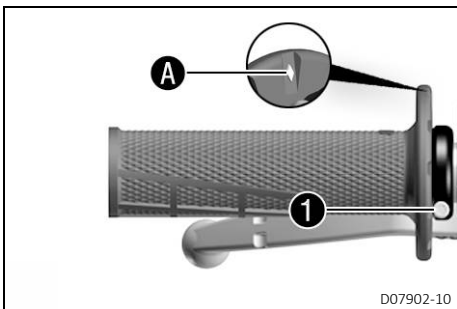

13.1 Adjusting the basic position of the hand brake lever

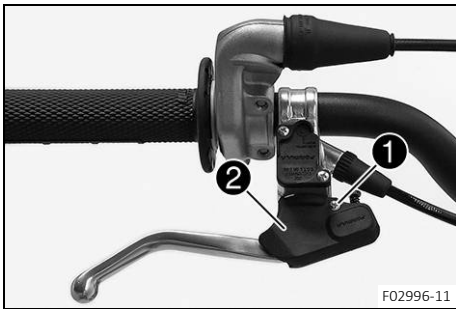

- Remove screw **1**. Take off cover **2**.

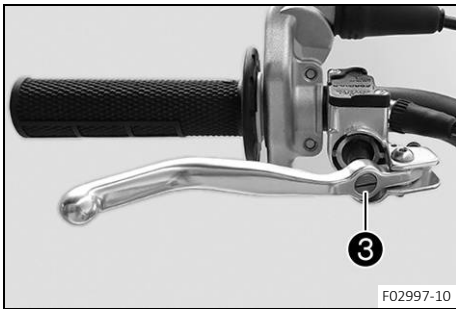

- Adjust the basic position of the hand brake lever with adjusting screw **3** to the rider's hand size.

i Info
 Turn the adjusting screw clockwise to increase the distance between the hand brake lever and the handlebar.
 Turn the adjusting screw counterclockwise to decrease the distance between the hand brake lever and the handlebar.
 The range of adjustment is limited.

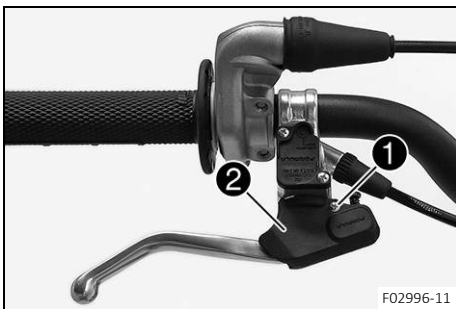

- Position cover **2**. Mount and tighten screw **1**.

13.2 Checking the brake discs



Warning
Danger of accidents Worn-out brake discs reduce the braking effect.

- Make sure that worn-out brake discs are replaced immediately. (Your authorized GASGAS Motorcycles workshop will be glad to help.)

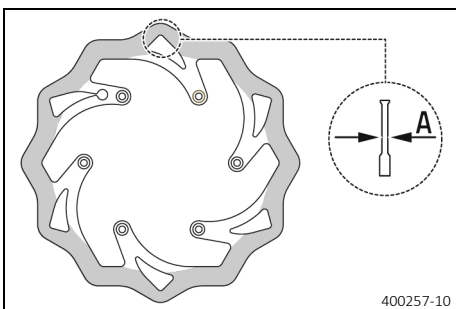

- Check the front and rear brake disc thickness at multiple points for the dimension **A**.

i Info
 Wear reduces the thickness of the brake disc around the contact surface of the brake linings.

Brake discs - wear limits	
front	2.2 mm (0.087 in)
rear	2.2 mm (0.087 in)

- » If the brake disc thickness is less than the specified value:
 - Change the front brake disc. 🛠️
 - Change the rear brake disc. 🛠️

- Check the front and rear brake discs for damage, cracking, and deformation.
 - » If the brake disc exhibits damage, cracking, or deformation:
 - Change the front brake disc. 🛠️
 - Change the rear brake disc. 🛠️

13.3 Checking the front brake fluid level



Warning

Danger of accidents An insufficient brake fluid level will cause the brake system to fail.

If the brake fluid level drops below the specified marking or the specified value, the brake system is leaking or the brake linings are worn down.

- Check the brake system and do not continue riding until the problem is eliminated. (Your authorized GAS-GAS Motorcycles workshop will be glad to help.)



Warning

Skin irritation Brake fluid is a harmful substance.

- Keep brake fluid out of the reach of children.
- Wear suitable protective clothing and safety glasses.
- Do not allow brake fluid to come into contact with the skin, the eyes or clothing.
- Consult a doctor immediately if brake fluid has been swallowed.
- Rinse the affected area with plenty of water in the event of contact with the skin.
- Rinse eyes thoroughly with water immediately and consult a doctor if brake fluid comes into contact with the eyes.
- If brake fluid spills on to your clothing, change the clothing.



Warning

Danger of accidents Brake fluid which is too old or of the wrong type impairs the function of the brake system.

- Make sure that brake fluid for the front and rear brake is changed in accordance with the service schedule. (Your authorized GASGAS Motorcycles workshop will be glad to help.)
- Make sure that only clean, approved brake fluid from a tightly sealed container is used. (Your authorized GAS-GAS Motorcycles workshop will be glad to help.)



Note

Environmental hazard Hazardous substances cause environmental damage.

- Dispose of oils, grease, filters, fuel, cleaning agents, brake fluid, etc., correctly and in compliance with the applicable regulations.



Info

Avoid contact between brake fluid and painted parts. Brake fluid corrodes paint.

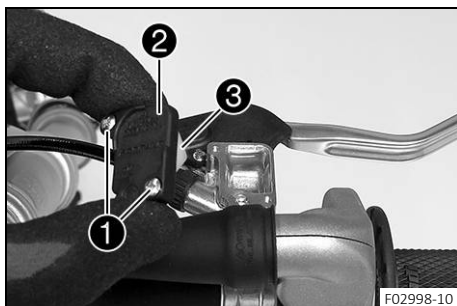

- Move the brake fluid reservoir mounted on the handlebar to a horizontal position.
- Remove screws ①.
- Take off cover ② with membrane ③.
- Check the brake fluid level.

Brake fluid level below reservoir rim	5 mm (0.2 in)
---------------------------------------	---------------

- » If the brake fluid level does not meet specifications:
 - Add front brake fluid. 🛠️ (📖 p. 71)

- Position the cover with the membrane. Mount and tighten the screws.

**Info**

Use water to immediately clean up any brake fluid that has overflowed or spilled.



13.4 Adding front brake fluid

**Warning**

Danger of accidents An insufficient brake fluid level will cause the brake system to fail.

If the brake fluid level drops below the specified marking or the specified value, the brake system is leaking or the brake linings are worn down.

- Check the brake system and do not continue riding until the problem is eliminated. (Your authorized GAS-GAS Motorcycles workshop will be glad to help.)

**Warning**

Skin irritation Brake fluid is a harmful substance.

- Keep brake fluid out of the reach of children.
- Wear suitable protective clothing and safety glasses.
- Do not allow brake fluid to come into contact with the skin, the eyes or clothing.
- Consult a doctor immediately if brake fluid has been swallowed.
- Rinse the affected area with plenty of water in the event of contact with the skin.
- Rinse eyes thoroughly with water immediately and consult a doctor if brake fluid comes into contact with the eyes.
- If brake fluid spills on to your clothing, change the clothing.

**Warning**

Danger of accidents Brake fluid which is too old or of the wrong type impairs the function of the brake system.

- Make sure that brake fluid for the front and rear brake is changed in accordance with the service schedule. (Your authorized GASGAS Motorcycles workshop will be glad to help.)
- Make sure that only clean, approved brake fluid from a tightly sealed container is used. (Your authorized GAS-GAS Motorcycles workshop will be glad to help.)

**Note**

Environmental hazard Hazardous substances cause environmental damage.

- Dispose of oils, grease, filters, fuel, cleaning agents, brake fluid, etc., correctly and in compliance with the applicable regulations.

**Info**

Avoid contact between brake fluid and painted parts. Brake fluid corrodes paint.

Preparatory work

- Check that the brake linings of the front brake are secured. ( p. 72)

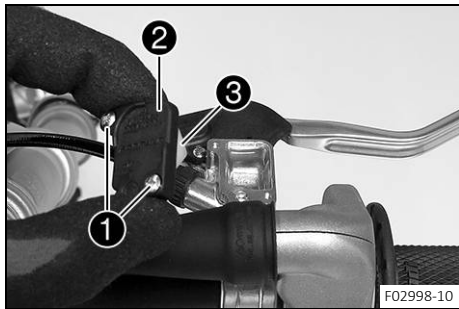

Main work

- Move the brake fluid reservoir mounted on the handlebar to a horizontal position.
- Remove screws ①.
- Take off cover ② with membrane ③.
- Correct the brake fluid level.

Guideline

Brake fluid level below reservoir rim	5 mm (0.2 in)
---------------------------------------	---------------

Brake fluid DOT 4 / DOT 5.1 (📖 p. 122)
--

- Position the cover with the membrane. Mount and tighten the screws.



Info

Use water to immediately clean up any brake fluid that has overflowed or spilled.

13.5 Checking that the brake linings of the front brake are secured



Warning

Danger of accidents Worn-out brake linings reduce the braking effect.

- Ensure that worn-out brake linings are replaced immediately. (Your authorized GASGAS Motorcycles workshop will be glad to help.)

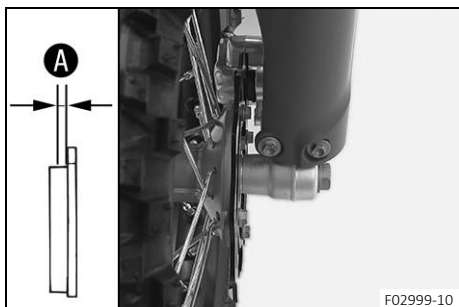

- Check the brake linings for lining thickness ①.

Minimum thickness ①	$\geq 1 \text{ mm } (\geq 0.04 \text{ in})$
---------------------	---

- » If it is less than the minimum thickness:
 - Change the brake linings of the front brake. 🛠️ (📖 p. 72)
- Check the brake linings for damage and cracking.
 - » If there is damage or cracking:
 - Change the brake linings of the front brake. 🛠️ (📖 p. 72)
- Check that the brake linings are secured.
 - » If the brake linings are not secured correctly:
 - Secure brake linings, replace with new parts if necessary.

13.6 Changing the front brake linings 🛠️



Warning

Danger of accidents Incorrect servicing will cause the brake system to fail.

- Ensure that service work and repairs are performed professionally. (Your authorized GASGAS Motorcycles workshop will be glad to help.)

**Warning****Skin irritation** Brake fluid is a harmful substance.

- Keep brake fluid out of the reach of children.
- Wear suitable protective clothing and safety glasses.
- Do not allow brake fluid to come into contact with the skin, the eyes or clothing.
- Consult a doctor immediately if brake fluid has been swallowed.
- Rinse the affected area with plenty of water in the event of contact with the skin.
- Rinse eyes thoroughly with water immediately and consult a doctor if brake fluid comes into contact with the eyes.
- If brake fluid spills on to your clothing, change the clothing.

**Warning****Danger of accidents** Brake fluid which is too old or of the wrong type impairs the function of the brake system.

- Make sure that brake fluid for the front and rear brake is changed in accordance with the service schedule. (Your authorized GASGAS Motorcycles workshop will be glad to help.)
- Make sure that only clean, approved brake fluid from a tightly sealed container is used. (Your authorized GASGAS Motorcycles workshop will be glad to help.)

**Warning****Danger of accidents** Brake linings which have not been approved alter the braking efficiency.

Not all brake linings are tested and approved for GASGAS motorcycles. The structure and friction coefficient of the brake linings, and thus their brake power, may vary greatly from that of original brake linings.

If brake linings are used that differ from the original equipment, compliance with the original homologation is not guaranteed. In this case, the vehicle no longer corresponds to its condition at delivery and the manufacturer warranty shall be void.

- Only use brake linings approved and recommended by GASGAS.

**Note****Environmental hazard** Hazardous substances cause environmental damage.

- Dispose of oils, grease, filters, fuel, cleaning agents, brake fluid, etc., correctly and in compliance with the applicable regulations.

**Info**

Avoid contact between brake fluid and painted parts. Brake fluid corrodes paint.

Preparatory work

- Raise the motorcycle with a lift stand. (📖 p. 42)

Main work

- Move the brake fluid reservoir mounted on the handlebar to a horizontal position.
- Remove screws ❶.
- Take off cover ❷ with membrane ❸.

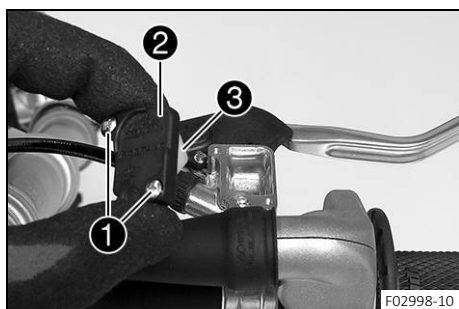

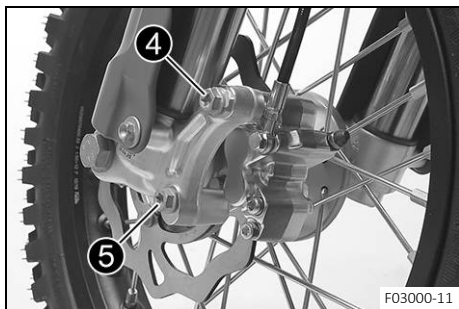

- Remove screw ④ and screw ⑤.
- Press back the brake linings by slightly tilting the brake caliper laterally on the brake disc. Carefully pull the brake caliper backward from the brake disc.
- Press the brake piston back into the basic position and ensure that brake fluid does not flow out of the brake fluid reservoir; extract some if necessary.

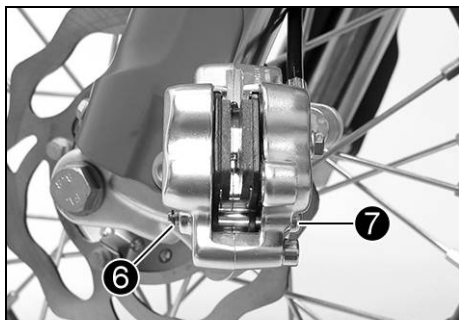

- Remove lock ring ⑥.
- Remove screw ⑦.
- Remove the brake linings.
- Clean the brake caliper and the brake caliper bracket.



Warning

Danger of accidents Brake linings which have not been approved alter the braking efficiency.

Not all brake linings are tested and approved for GASGAS motorcycles. The structure and friction coefficient of the brake linings, and thus their brake power, may vary greatly from that of original brake linings.

If brake linings are used that differ from the original equipment, compliance with the original homologation is not guaranteed. In this case, the vehicle no longer corresponds to its condition at delivery and the manufacturer warranty shall be void.

- Only use brake linings approved and recommended by GASGAS.

- Position the new brake linings.



Info

Always change the brake linings in pairs. Ensure that the brake linings are correctly positioned in the holding spring.

- Mount and tighten screw ⑦.

Guideline

Screw, brake linings	M5	8 Nm (5.9 lbf ft)
----------------------	----	-------------------

- Mount lock ring ⑥.



Warning

Danger of accidents Oil or grease on the brake discs reduces the braking effect.

- Always keep the brake discs free of oil and grease.
- Clean the brake discs with brake cleaner when necessary.

- Check the brake discs. (📖 p. 69)

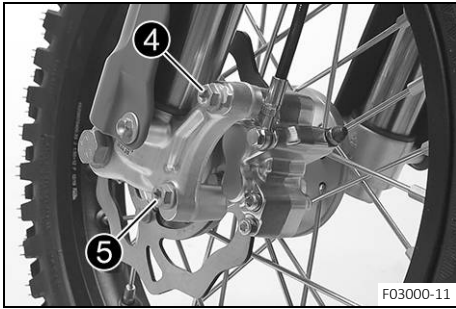

- Position the brake caliper.
- Mount screw ④, but do not tighten it yet.

Guideline

Screw, front brake caliper	M8x60	20 Nm (14.8 lbf ft) Loctite®243™
----------------------------	-------	--

- Mount screw ⑤, but do not tighten it yet.

Guideline

Screw, front brake caliper	M8x40	20 Nm (14.8 lbf ft) Loctite®243™
----------------------------	-------	--

- Operate the hand brake lever repeatedly until the brake linings are in contact with the brake disc and there is a pressure point. Secure the hand brake lever in the activated position.

✓ The brake caliper straightens.

- Tighten screw ④.

Guideline

Screw, front brake caliper	M8x60	20 Nm (14.8 lbf ft) Loctite®243™
----------------------------	-------	--

- Tighten screw ⑤.

Guideline

Screw, front brake caliper	M8x40	20 Nm (14.8 lbf ft) Loctite®243™
----------------------------	-------	--

- Remove the locking piece of the hand brake lever.

- Correct the brake fluid level.

Guideline

Brake fluid level below reservoir rim	5 mm (0.2 in)
---------------------------------------	---------------

Brake fluid DOT 4 / DOT 5.1 (📖 p. 122)
--

- Position cover ② with membrane ③.
- Mount and tighten screws ①.

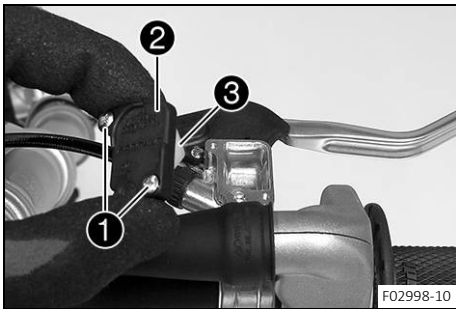

Info

Use water to immediately clean up any brake fluid that has overflowed or spilled.

Finishing work

- Remove the motorcycle from the lift stand. (📖 p. 42)

13.7 Checking the free travel of the foot brake lever



Warning

Danger of accidents The brake system will fail if it overheats or is adjusted incorrectly.

If there is no free travel on the foot brake lever, pressure builds up in the brake system on the rear brake.

- Set the free travel on the foot brake lever in accordance with the specification.
- Ensure that the adjustment steps are performed properly. (Your authorized GASGAS Motorcycles workshop will be glad to help.)

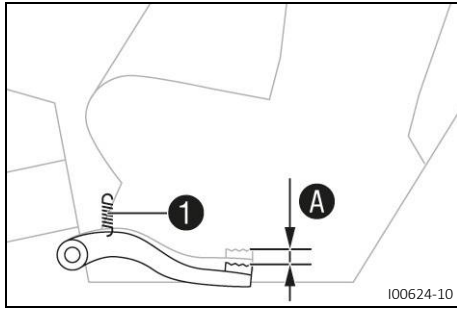

- Detach spring ①.
- Move the foot brake lever back and forth between the end stop and the contact to the foot brake cylinder piston and check free travel A.

Guideline

Free travel of foot brake lever	3 ... 5 mm (0.12 ... 0.2 in)
---------------------------------	------------------------------

- » If the free travel does not match the specification:
 - Adjust the free travel of the hand brake lever. 🛠️ (p. 76)
- Attach spring ①.

13.8 Adjusting the free travel of the foot brake lever 🛠️



Warning

Danger of accidents The brake system will fail if it overheats or is adjusted incorrectly.

If there is no free travel on the foot brake lever, pressure builds up in the brake system on the rear brake.

- Set the free travel on the foot brake lever in accordance with the specification.
- Ensure that the adjustment steps are performed properly. (Your authorized GASGAS Motorcycles workshop will be glad to help.)

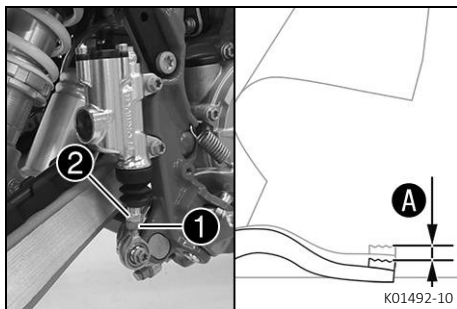

- Detach the foot brake lever spring.
- Loosen nut ①.
- Turn push rod ② accordingly until you have free travel A.

Guideline

Free travel of foot brake lever	3 ... 5 mm (0.12 ... 0.2 in)
---------------------------------	------------------------------

- Hold push rod ② and tighten nut ①.

Guideline

Nut, push rod, foot brake lever	M6	6 Nm (4.4 lbf ft)
---------------------------------	----	-------------------

- Attach the foot brake lever spring.
- Check whether the basic position of the foot brake lever is suitable for the rider.
 - » When the basic position of the foot brake lever needs to be adjusted:
 - Adjust the basic position of the foot brake lever. 🛠️ (p. 76)

13.9 Adjusting the basic position of the foot brake lever 🛠️



Warning

Danger of accidents The brake system will fail if it overheats or is adjusted incorrectly.

If there is no free travel on the foot brake lever, pressure builds up in the brake system on the rear brake.

- Set the free travel on the foot brake lever in accordance with the specification.
- Ensure that the adjustment steps are performed properly. (Your authorized GASGAS Motorcycles workshop will be glad to help.)

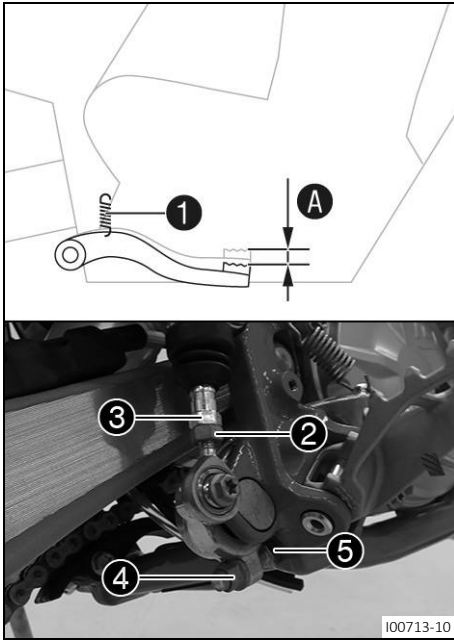

- Detach spring ①.
- Loosen nut ② and, with push rod ③, turn it back until you have maximum free travel.
- To adjust the basic position of the foot brake lever to individual requirements, loosen nut ④ and turn screw ⑤ accordingly.

i Info
The range of adjustment is limited.

- Turn push rod ③ accordingly until you have free travel A. If necessary, adjust the basic position of the foot brake lever.

Guideline

Free travel of foot brake lever	3 ... 5 mm (0.12 ... 0.2 in)
---------------------------------	------------------------------

- Hold screw ⑤ and tighten nut ④.

Guideline

Bushing, foot brake lever stop	M8	20 Nm (14.8 lbf ft)
--------------------------------	----	---------------------

- Hold push rod ③ and tighten nut ②.

Guideline

Nut, push rod, foot brake lever	M6	6 Nm (4.4 lbf ft)
---------------------------------	----	-------------------

- Attach spring ①.



13.10 Checking the rear brake fluid level



Warning

Danger of accidents An insufficient brake fluid level will cause the brake system to fail.

If the brake fluid level drops below the specified marking or the specified value, the brake system is leaking or the brake linings are worn down.

- Check the brake system and ensure that nobody drives the vehicle before the problem is eliminated. (Your authorized GASGAS Motorcycles workshop will be glad to help.)



Warning

Danger of accidents Brake fluid which is too old or of the wrong type impairs the function of the brake system.

- Make sure that brake fluid for the front and rear brake is changed in accordance with the service schedule. (Your authorized GASGAS Motorcycles workshop will be glad to help.)
- Make sure that only clean, approved brake fluid from a tightly sealed container is used. (Your authorized GASGAS Motorcycles workshop will be glad to help.)

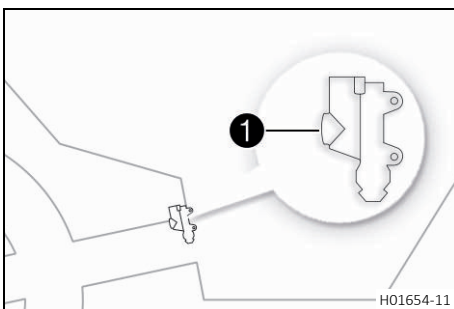

- Stand the vehicle upright.
- Check the brake fluid level in level viewer ①.
 - » If an air bubble is visible in viewer ①:
 - Add rear brake fluid. 📖 (p. 78)



13.11 Adding rear brake fluid



Warning

Danger of accidents An insufficient brake fluid level will cause the brake system to fail.

If the brake fluid level drops below the specified marking or the specified value, the brake system is leaking or the brake linings are worn down.

- Check the brake system and ensure that nobody drives the vehicle before the problem is eliminated. (Your authorized GASGAS Motorcycles workshop will be glad to help.)



Warning

Skin irritation Brake fluid is a harmful substance.

- Keep brake fluid out of the reach of children.
- Wear suitable protective clothing and safety glasses.
- Do not allow brake fluid to come into contact with the skin, the eyes or clothing.
- Consult a doctor immediately if brake fluid has been swallowed.
- Rinse the affected area with plenty of water in the event of contact with the skin.
- Rinse eyes thoroughly with water immediately and consult a doctor if brake fluid comes into contact with the eyes.
- If brake fluid spills on to your clothing, change the clothing.



Warning

Danger of accidents Brake fluid which is too old or of the wrong type impairs the function of the brake system.

- Make sure that brake fluid for the front and rear brake is changed in accordance with the service schedule. (Your authorized GASGAS Motorcycles workshop will be glad to help.)
- Make sure that only clean, approved brake fluid from a tightly sealed container is used. (Your authorized GASGAS Motorcycles workshop will be glad to help.)



Note

Environmental hazard Hazardous substances cause environmental damage.

- Dispose of oils, grease, filters, fuel, cleaning agents, brake fluid, etc., correctly and in compliance with the applicable regulations.



Info

Avoid contact between brake fluid and painted parts. Brake fluid corrodes paint.

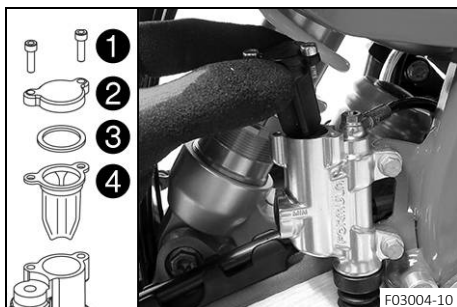

Preparatory work

- Raise the motorcycle with a lift stand. (📖 p. 42)
- Check that the brake linings of the rear brake are secured. (📖 p. 79)

Main work

- Remove screws ①.
- Take off cover ② with washer ③ and membrane ④.

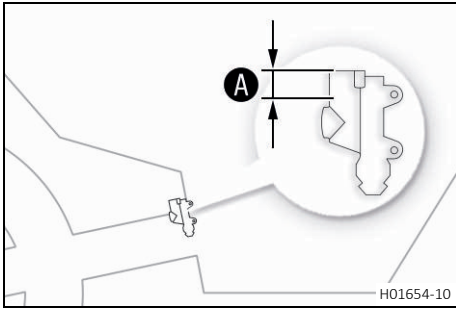

- Add brake fluid up to level **A**.

Guideline

Level A (brake fluid level below reservoir rim)	10 mm (0.39 in)
--	-----------------

Brake fluid DOT 4 / DOT 5.1 (📖 p. 122)
--

- Position cover with washer and membrane.
- Mount and tighten the screws.

i Info
Use water to immediately clean up any brake fluid that has overflowed or spilled.

Finishing work

- Remove the motorcycle from the lift stand. (📖 p. 42)



13.12 Checking that the brake linings of the rear brake are secured



Warning

Danger of accidents Worn-out brake linings reduce the braking effect.

- Ensure that worn-out brake linings are replaced immediately. (Your authorized GASGAS Motorcycles workshop will be glad to help.)

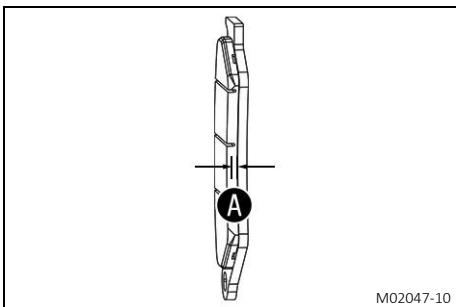

- Check the brake linings for minimum thickness **A**.

Minimum thickness A	$\geq 1 \text{ mm } (\geq 0.04 \text{ in})$
----------------------------	---

- » If the minimum thickness is less than specified:
 - Change the rear brake linings. (🔧📖 p. 79)
- Check the brake linings for damage and cracking.
 - » If damage or wear is encountered:
 - Change the rear brake linings. (🔧📖 p. 79)
- Check that the brake linings are secured.
 - » If the brake linings are not secured correctly:
 - Secure brake linings, replace with new parts if necessary.



13.13 Changing the rear brake linings 🔧



Warning

Danger of accidents Incorrect servicing will cause the brake system to fail.

- Ensure that service work and repairs are performed professionally. (Your authorized GASGAS Motorcycles workshop will be glad to help.)



Warning

Skin irritation Brake fluid is a harmful substance.

- Keep brake fluid out of the reach of children.
- Wear suitable protective clothing and safety glasses.
- Do not allow brake fluid to come into contact with the skin, the eyes or clothing.
- Consult a doctor immediately if brake fluid has been swallowed.
- Rinse the affected area with plenty of water in the event of contact with the skin.
- Rinse eyes thoroughly with water immediately and consult a doctor if brake fluid comes into contact with the eyes.
- If brake fluid spills on to your clothing, change the clothing.



Warning

Danger of accidents Brake fluid which is too old or of the wrong type impairs the function of the brake system.

- Make sure that brake fluid for the front and rear brake is changed in accordance with the service schedule. (Your authorized GASGAS Motorcycles workshop will be glad to help.)
- Make sure that only clean, approved brake fluid from a tightly sealed container is used. (Your authorized GASGAS Motorcycles workshop will be glad to help.)



Warning

Danger of accidents Oil or grease on the brake discs reduces the braking effect.

- Always keep the brake discs free of oil and grease.
- Clean the brake discs with brake cleaner when necessary.



Warning

Danger of accidents Brake linings which have not been approved alter the braking efficiency.

Not all brake linings are tested and approved for GASGAS motorcycles. The structure and friction coefficient of the brake linings, and thus their brake power, may vary greatly from that of original brake linings.

If brake linings are used that differ from the original equipment, compliance with the original homologation is not guaranteed. In this case, the vehicle no longer corresponds to its condition at delivery and the manufacturer warranty shall be void.

- Only use brake linings approved and recommended by GASGAS.



Note

Environmental hazard Hazardous substances cause environmental damage.

- Dispose of oils, grease, filters, fuel, cleaning agents, brake fluid, etc., correctly and in compliance with the applicable regulations.



Info

Avoid contact between brake fluid and painted parts. Brake fluid corrodes paint.

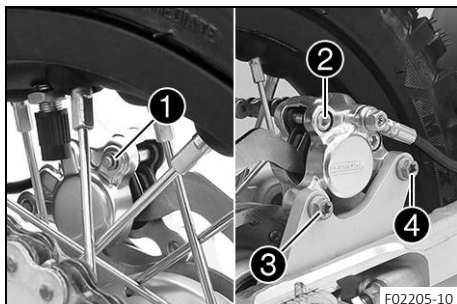

Preparatory work

- Raise the motorcycle with a lift stand. (📖 p. 42)

Main work

- Remove lock ring **1**.
- Remove screw **2**.
- Remove screw **3** and screw **4**.

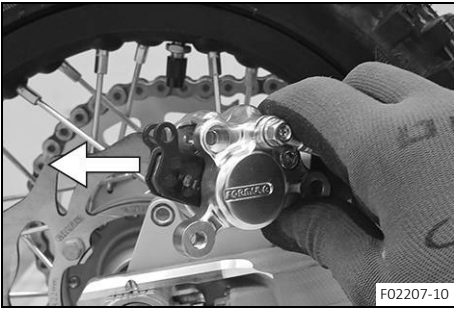

- Take off the brake caliper.

i Info
Do not kink or damage the brake line.

- Remove the brake linings.
- Clean the brake caliper and the brake caliper bracket.
- Allow the brake caliper and the brake line to hang loosely to the side.
- Check the brake discs. (📖 p. 69)

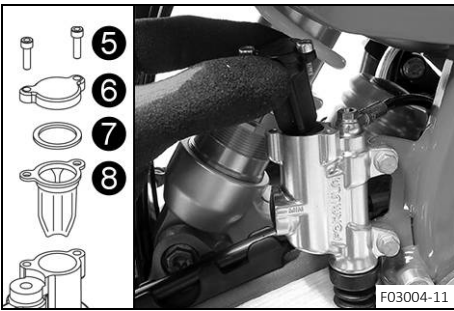

- Remove screws **5**.
- Take off cover **6** with washer **7** and membrane **8**.
- Press the brake piston back to its basic position and make sure that no brake fluid overflows from the brake fluid reservoir, extract brake fluid if necessary.

- Position the new brake linings.

i Info
Always change the brake linings in pairs.
Ensure that the brake linings are correctly positioned in the holding spring.

- Position the brake caliper on the brake disc.
✓ The brake linings are correctly positioned.

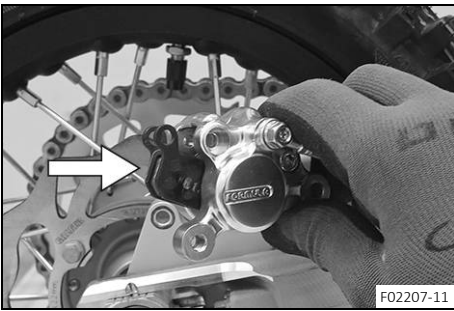

- Mount and tighten screw **3**.

Guideline

Screw, rear brake caliper	M6x16	10 Nm (7.4 lbf ft) Loctite® 243™
---------------------------	-------	--

- Mount and tighten screw **4**.

Guideline

Screw, rear brake caliper	M6x40	10 Nm (7.4 lbf ft) Loctite® 243™
---------------------------	-------	--

- Mount and tighten screw **2**.

Guideline

Screw, brake linings	M5	8 Nm (5.9 lbf ft)
----------------------	----	-------------------

- Mount lock ring **1**.
- Check the brake discs. (📖 p. 69)
- Operate the foot brake lever repeatedly until the brake linings are in contact with the brake disc and there is a pressure point.

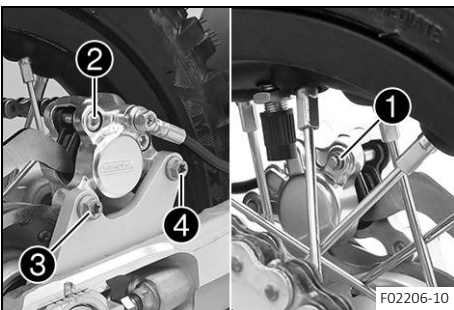

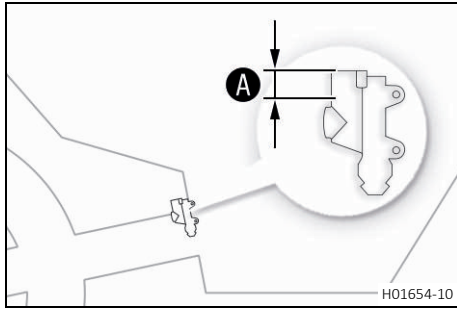

- Add brake fluid up to level **A**.

Guideline

Level A (brake fluid level below reservoir rim)	10 mm (0.39 in)
--	-----------------

Brake fluid DOT 4 / DOT 5.1 (📖 p. 122)
--

- Position cover with washer and membrane.
- Mount and tighten the screws.



Info

Use water to immediately clean up any brake fluid that has overflowed or spilled.

Finishing work

- Remove the motorcycle from the lift stand. (📖 p. 42)

14.1 Removing the front wheel ↩

Preparatory work

- Raise the motorcycle with a lift stand. (🔧 p. 42)

Main work

- Loosen screw ❶ by several rotations.
- Loosen screws ❷.
- Press on screw ❶ to push the wheel spindle out of the axle clamp.
- Remove screw ❶.

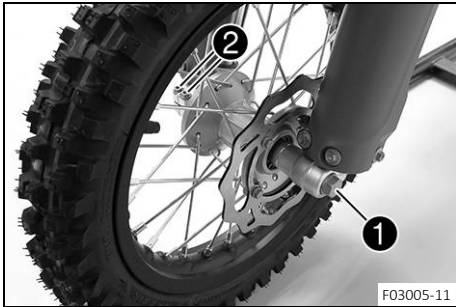

Warning

Danger of accidents Damaged brake discs reduce the braking effect.

- Always lay the wheel down in such a way that the brake disc is not damaged.

- Hold front wheel and remove wheel spindle. Take the front wheel out of the fork.



Info

Do not actuate the hand brake lever when the front wheel is removed.

- Remove spacers ❸.

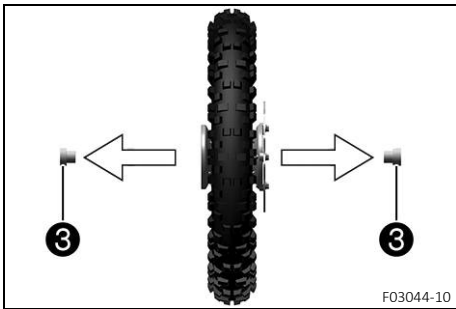

14.2 Installing the front wheel ↩



Warning

Danger of accidents Oil or grease on the brake discs reduces the braking effect.

- Always keep the brake discs free of oil and grease.
- Clean the brake discs with brake cleaner when necessary.

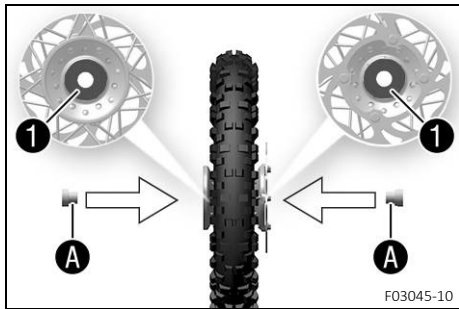

- Check the wheel bearing for damage and wear.
 - » If the wheel bearing is damaged or worn:
 - Change front wheel bearing. 🛠️
- Clean and grease shaft seal rings 1 and contact surfaces A of the spacers.

Long-life grease (📖 p. 124)

- Insert the spacers.

i Info

Insert the wide spacer on the left in the direction of travel.

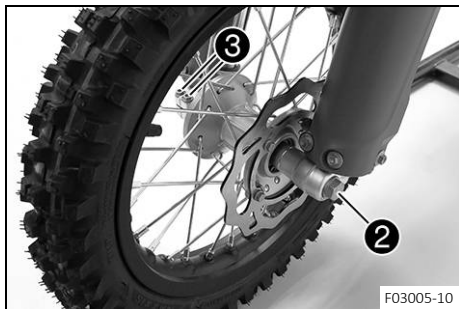

- Clean and grease the wheel spindle.

Long-life grease (📖 p. 124)

- Position the front wheel.
 - ✓ The brake linings are correctly positioned.
- Insert the wheel spindle.
- Mount and tighten screw 2.

Guideline

Screw, front wheel spindle	M10	40 Nm (29.5 lbf ft) Loctite®243™
----------------------------	-----	--

- Operate the hand brake lever several times until the brake linings are seated correctly against the brake disc.
- Remove the motorcycle from the lift stand. (📖 p. 42)
- Operate the front brake and compress the fork a few times firmly.
 - ✓ The fork legs straighten.
- Tighten screws 3.

Guideline

Screw, fork stub	M6	10 Nm (7.4 lbf ft)
------------------	----	--------------------

14.3 Removing the rear wheel 🛠️

Preparatory work

- Raise the motorcycle with a lift stand. (📖 p. 42)

Main work

- Remove nut 1.
- Take off chain adjuster 2.

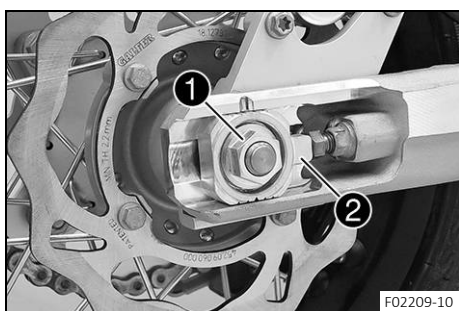

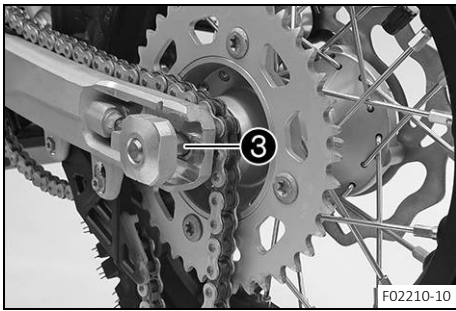

- Pull out wheel spindle **3** far enough to allow the rear wheel to be pushed forward.
- Push the rear wheel forward as far as possible. Remove the chain from the rear sprocket.

i Info
Cover the components to protect them against damage.

! Warning
Danger of accidents Damaged brake discs reduce the braking effect.
- Always lay the wheel down in such a way that the brake disc is not damaged.

- Hold the rear wheel and remove the wheel spindle. Take the rear wheel out of the link fork.

i Info
Do not operate the foot brake lever when the rear wheel is removed.

- Remove spacers **4**.

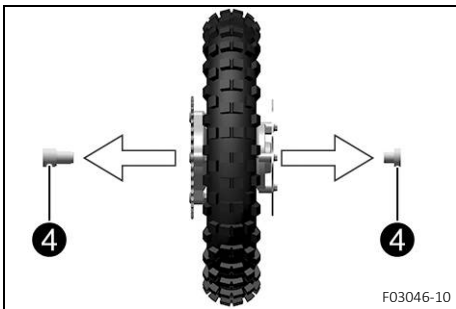

14.4 Installing the rear wheel

! Warning
Danger of accidents Oil or grease on the brake discs reduces the braking effect.
- Always keep the brake discs free of oil and grease.
- Clean the brake discs with brake cleaner when necessary.

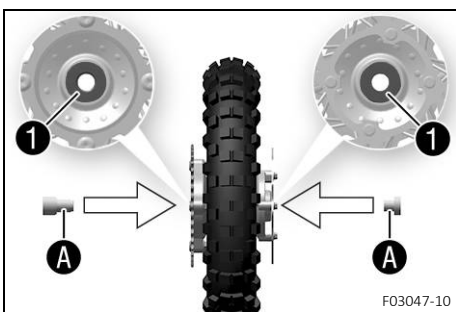

Main work

- Check the wheel bearing for damage and wear.
 - » If the wheel bearing is damaged or worn:
 - Change the rear wheel bearing.
- Clean and grease shaft seal rings **1** and contact surfaces **A** of the spacers.

Long-life grease (📖 p. 124)

- Insert the spacers.

i Info
Insert the wide spacer on the left in the direction of travel.

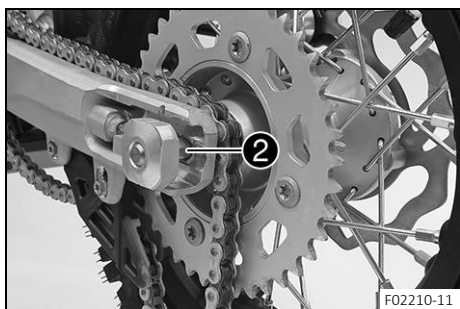

- Clean and grease the wheel spindle.

Long-life grease (📖 p. 124)

- Position rear wheel and mount the chain.
 - ✓ The brake linings are correctly positioned.
- Insert wheel spindle ②.

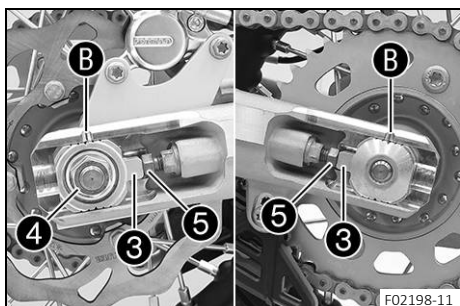

- Position chain adjuster ③. Mount nut ④, but do not tighten it yet.
- Make sure that chain adjusters ③ are fitted correctly on adjusting screws ⑤.
- Make sure that the markings on the left and right chain adjusters ③ are in the same position relative to reference marks B. The rear wheel is then correctly aligned.

i Info

The wide adjustment range of the chain adjusters enables different secondary ratios with the same chain length. Chain adjusters ③ can be turned by 180°.

- Check the chain tension. (📖 p. 63)
- Tighten nut ④.

Guideline

Rear wheel spindle nut	M12x1	70 Nm (51.6 lbf ft)
------------------------	-------	---------------------

- Operate the foot brake lever repeatedly until the brake linings are in contact with the brake disc and there is a pressure point.

Finishing work

- Remove the motorcycle from the lift stand. (📖 p. 42)

14.5 Checking the tire condition

i Info

Only mount tires approved and/or recommended by GASGAS. Other tires could have a negative effect on handling characteristics. The type, condition, and pressure of the tires all have a major impact on the handling characteristics of the motorcycle. The tires mounted on the front and rear wheels must have a similar profile. Worn tires have a negative effect on handling characteristics, especially on wet surfaces.

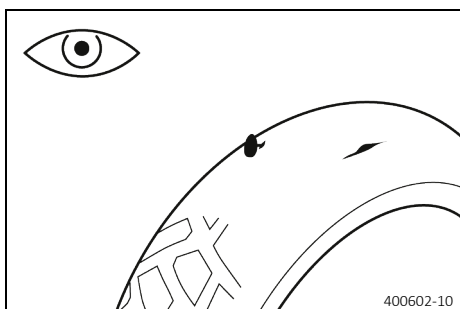

- Check the front and rear tires for cuts, embedded objects, and other damage.
 - » If the tires have cuts, run-in objects, or other damage:
 - Change the tires. 🛠️

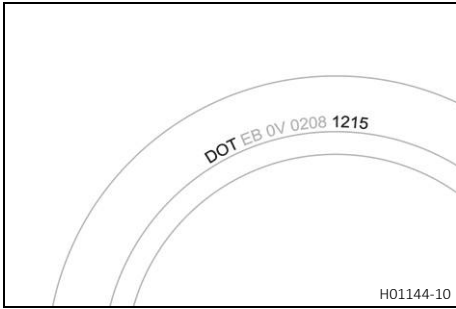

- Check the tire age.

i Info
 The tire date of manufacture is usually contained in the tire label and is indicated by the last four digits of the **DOT** number. The first two digits indicate the week of manufacture and the last two digits the year of manufacture.
 GASGAS recommends that the tires be changed after 5 years at the latest, regardless of the actual state of wear.

- » If the tires are older than five years:
 - Change the tires. 🛠️

14.6 Checking tire pressure

i Info
 Low tire pressure leads to abnormal wear and overheating of the tire.
 Correct tire pressure ensures optimal riding comfort and maximum tire service life.

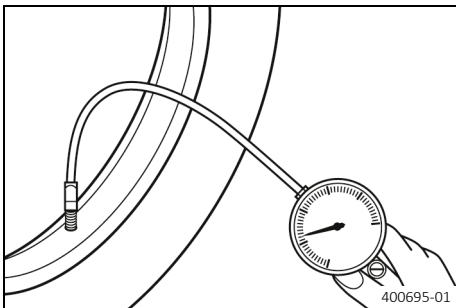

- Remove protection cap.
- Check tire pressure when the tires are cold.

Offroad tire pressure	
front	1.0 bar (15 psi)
rear	1.0 bar (15 psi)

- » If the tire pressure does not meet specifications:
 - Correct tire pressure.
- Mount the protection cap.

14.7 Checking the spoke tension

! Warning
Danger of accidents Incorrectly tensioned spokes impair the handling characteristic and result in secondary damage.

The spokes break due to being overloaded if they are too tightly tensioned. If the tension in the spokes is too low, then lateral and radial run-out will form in the wheel. Other spokes will become looser as a result.

- Check spoke tension regularly, and in particular on a new vehicle. (Your authorized GASGAS Motorcycles workshop will be glad to help.)

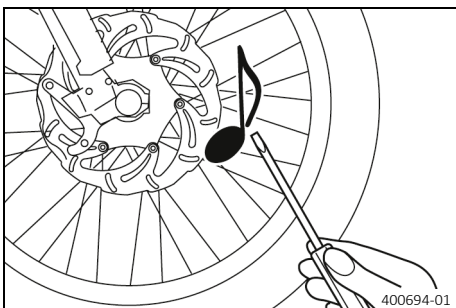

- Strike each spoke briefly using a screwdriver blade.

i Info
 The frequency of the sound depends on the spoke length and spoke diameter.
 If spokes of the same length and diameter vibrate with a different tone, this is an indication that the spoke tensions differ.

You should hear a high note.

- » If the spoke tension differs:
 - Correct the spoke tension. 🛠️
- Check the spoke torque.

Guideline

Spoke nipple	M3.5	3 Nm (2.2 lbf ft)
--------------	------	-------------------

Torque wrench kit (58429094000)



15.1 Cooling system

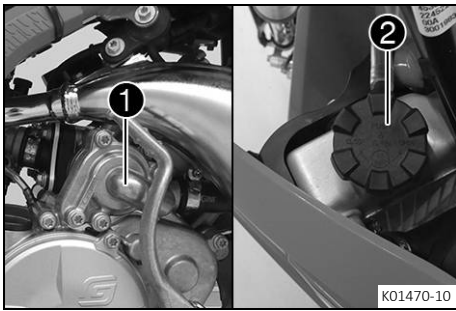

The water pump ① in the engine forces the coolant to flow. The pressure resulting from the warming of the cooling system is regulated by a valve in the radiator cap ②. This ensures that operating the vehicle at the specified coolant temperature will not result in a risk of malfunctions.

120 °C (248 °F)

Cooling is effected by the air stream. The lower the speed, the less the cooling effect. Dirty cooling fins also reduce the cooling effect.

15.2 Checking the antifreeze and coolant level



Warning

Danger of scalding During motorcycle operation, the coolant gets hot and is under pressure.

- Do not open the radiator, the radiator hoses or other cooling system components if the engine or the cooling system are at operating temperature.
- Allow the cooling system and the engine to cool down before you open the radiator, the radiator hoses or other components of the cooling system.
- In the event of scalding, rinse the area affected immediately with lukewarm water.



Warning

Danger of poisoning Coolant is harmful to health.

- Keep coolant out of the reach of children.
- Do not allow coolant to come into contact with the skin, the eyes and clothing.
- Consult a doctor immediately if coolant is swallowed.
- Rinse the affected area immediately with plenty of water in the event of contact with the skin.
- Rinse eyes thoroughly with water and consult a doctor immediately if coolant gets into the eyes.
- Change clothing if coolant spills onto your clothing.



- Stand the motorcycle upright on a horizontal surface.
- Take off radiator cap ①.
- Check the antifreeze in the coolant.

-25 ... -45 °C (-13 ... -49 °F)

- » If the antifreeze in the coolant does not match the specified value:
 - Correct the antifreeze in the coolant.

- Check the coolant level in the radiator.

Coolant level ① above the radiator fins	10 mm (0.39 in)
---	-----------------

- » If the coolant level does not match the specified value:
 - Correct the coolant level.

Coolant (📖 p. 122)

- Mount the radiator cap.

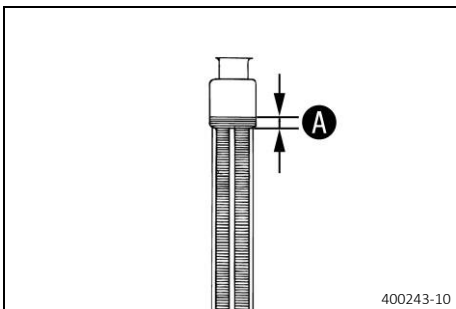

15.3 Checking the coolant level



Warning

Danger of scalding During motorcycle operation, the coolant gets hot and is under pressure.

- Do not open the radiator, the radiator hoses or other cooling system components if the engine or the cooling system are at operating temperature.
- Allow the cooling system and the engine to cool down before you open the radiator, the radiator hoses or other components of the cooling system.
- In the event of scalding, rinse the area affected immediately with lukewarm water.



Warning

Danger of poisoning Coolant is harmful to health.

- Keep coolant out of the reach of children.
- Do not allow coolant to come into contact with the skin, the eyes and clothing.
- Consult a doctor immediately if coolant is swallowed.
- Rinse the affected area immediately with plenty of water in the event of contact with the skin.
- Rinse eyes thoroughly with water and consult a doctor immediately if coolant gets into the eyes.
- Change clothing if coolant spills onto your clothing.

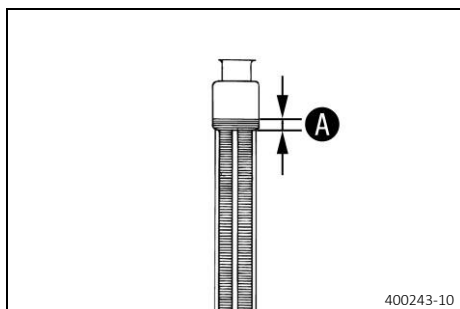

- Stand the motorcycle upright on a horizontal surface.
- Remove the radiator cap.
- Check the coolant level in the radiator.

Coolant level A above the radiator fins	10 mm (0.39 in)
--	-----------------

» If the coolant level does not match the specified value:

- Correct the coolant level.

Coolant (📖 p. 122)

- Mount the radiator cap.

15.4 Draining the coolant 🚰



Warning

Danger of scalding During motorcycle operation, the coolant gets hot and is under pressure.

- Do not open the radiator, the radiator hoses or other cooling system components if the engine or the cooling system are at operating temperature.
- Allow the cooling system and the engine to cool down before you open the radiator, the radiator hoses or other components of the cooling system.
- In the event of scalding, rinse the area affected immediately with lukewarm water.



Warning

Danger of poisoning Coolant is harmful to health.

- Keep coolant out of the reach of children.
- Do not allow coolant to come into contact with the skin, the eyes and clothing.
- Consult a doctor immediately if coolant is swallowed.
- Rinse the affected area immediately with plenty of water in the event of contact with the skin.
- Rinse eyes thoroughly with water and consult a doctor immediately if coolant gets into the eyes.
- Change clothing if coolant spills onto your clothing.

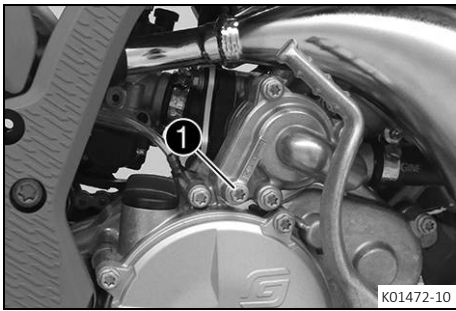

Condition

The engine is cold.

- Position the motorcycle upright.
- Place an appropriate container under the water pump cover.
- Remove screw ①. Take off the radiator cap.
- Completely drain the coolant.
- Mount and tighten screw ① with a new seal ring.

Guideline

Drain plug, water pump cover	M6	6 Nm (4.4 lbf ft)
------------------------------	----	-------------------

15.5 Refilling with coolant



Warning

Danger of poisoning Coolant is harmful to health.

- Keep coolant out of the reach of children.
- Do not allow coolant to come into contact with the skin, the eyes and clothing.
- Consult a doctor immediately if coolant is swallowed.
- Rinse the affected area immediately with plenty of water in the event of contact with the skin.
- Rinse eyes thoroughly with water and consult a doctor immediately if coolant gets into the eyes.
- Change clothing if coolant spills onto your clothing.

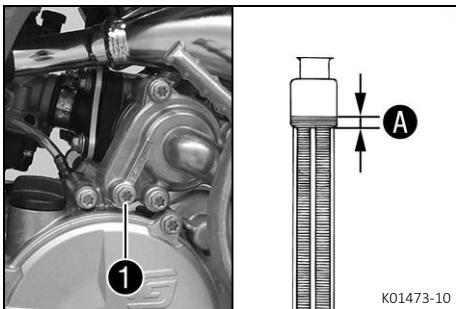

Main work

- Make sure that screw ① is tightened.
- Position the motorcycle upright.
- Add coolant to level A.

Guideline

Distance A above the radiator fins	10 mm (0.39 in)
------------------------------------	-----------------

Coolant	0.7 l (0.7 qt.)	Coolant (📖 p. 122)
---------	-----------------	--------------------

- Move the vehicle into the position shown and prevent it from rolling away. Height difference B must be reached.

Guideline

Height difference B	50 cm (19.7 in)
---------------------	-----------------

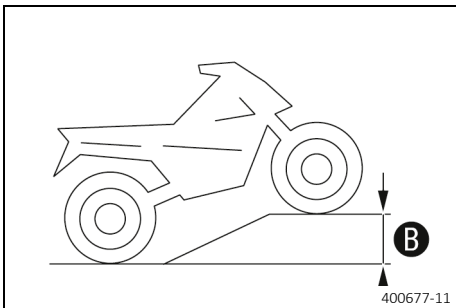

i Info

For all of the air to be able to escape from the cooling system, the vehicle must be raised at the front. If the cooling system is poorly de-aerated, its cooling power will be reduced and the engine may overheat.

- Return the vehicle to the horizontal position.
- Add coolant to level A.
- Mount the radiator cap.

Finishing work

- Go for a short test ride.
- Check the cooling system for leaks.
- Check the coolant level. (📖 p. 90)

15.6 Changing the coolant



Warning

Danger of scalding During motorcycle operation, the coolant gets hot and is under pressure.

- Do not open the radiator, the radiator hoses or other cooling system components if the engine or the cooling system are at operating temperature.
- Allow the cooling system and the engine to cool down before you open the radiator, the radiator hoses or other components of the cooling system.
- In the event of scalding, rinse the area affected immediately with lukewarm water.



Warning

Danger of poisoning Coolant is harmful to health.

- Keep coolant out of the reach of children.
- Do not allow coolant to come into contact with the skin, the eyes and clothing.
- Consult a doctor immediately if coolant is swallowed.
- Rinse the affected area immediately with plenty of water in the event of contact with the skin.
- Rinse eyes thoroughly with water and consult a doctor immediately if coolant gets into the eyes.
- Change clothing if coolant spills onto your clothing.

Condition

The engine is cold.

- Position the motorcycle upright.
- Place an appropriate container under the water pump cover.
- Remove screw **1**. Take off the radiator cap.
- Completely drain the coolant.
- Mount and tighten screw **1** with a new seal ring.

Guideline

Drain plug, water pump cover	M6	6 Nm (4.4 lbf ft)
------------------------------	----	-------------------

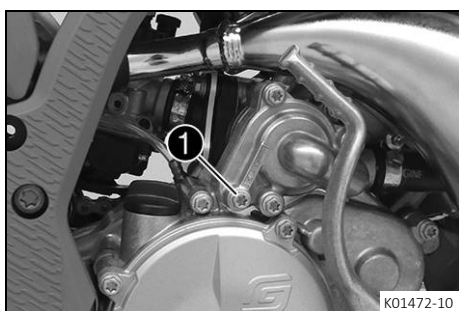

- Add coolant to level **A**.

Guideline

Distance A above the radiator fins	10 mm (0.39 in)
---	-----------------

Coolant	0.7 l (0.7 qt.)	Coolant (📖 p. 122)
---------	-----------------	--------------------

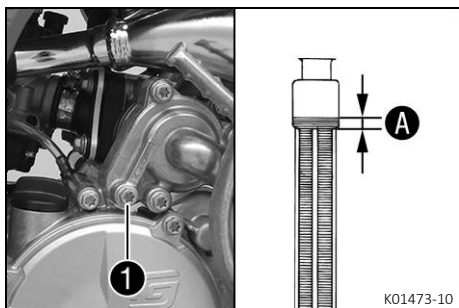

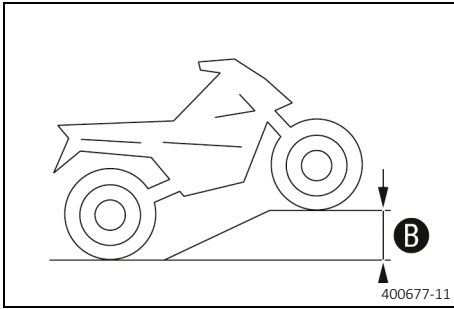

- Move the vehicle into the position shown and secure it against rolling away. Height difference **B** must be reached.

Guideline

Height difference B	50 cm (19.7 in)
----------------------------	-----------------



Info

For all of the air to be able to escape from the cooling system, the vehicle must be raised at the front. If the cooling system is poorly de-aerated, its cooling power will be reduced and the engine may overheat.

- Return the vehicle to the horizontal position.
- Add coolant to level **A**.
- Mount the radiator cap.

Finishing work

- Go for a short test ride.
- Check the cooling system for leaks.
- Check the coolant level. (🗨️ p. 90)



16.1 Checking the play in the throttle cable

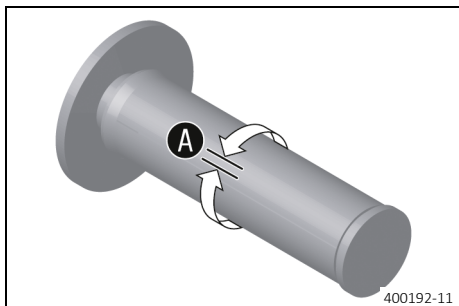

- Check the throttle grip for smooth operation.
- Move the handlebar to the straight-ahead position. Turn the throttle grip back and forth slightly and determine the play in throttle cable **A**.

Play in throttle cable	3 ... 5 mm (0.12 ... 0.2 in)
------------------------	------------------------------

- » If the throttle cable play does not meet the specified value:
 - Adjust the play in the throttle cable. 🛠️ (p. 94)



Danger

Danger of poisoning Exhaust gases are toxic and inhaling them may result in unconsciousness and death.

- Always make sure there is sufficient ventilation when running the engine.
- Use effective exhaust extraction when starting or running the engine in an enclosed space.

- Start the engine and let it run at idle speed. Move the handlebar to and fro over the entire steering range.

The idle speed must not change.

- » If the idle speed changes:
 - Adjust the play in the throttle cable. 🛠️ (p. 94)

16.2 Adjusting the play in the throttle cable 🛠️

Preparatory work

- Remove the seat. (📖 p. 57)
- Turn the knurled screw on the fuel tap all the way clockwise.
- Remove the fuel tank. 🛠️ (📖 p. 50)
- Check the throttle cable routing. (📖 p. 67)

Main work

- Move the handlebar to the straight-ahead position.
- Push back sleeve **1**.
- Ensure that the throttle cable sleeve is pushed all the way into barrel adjuster **2**.
- Loosen nut **3**.

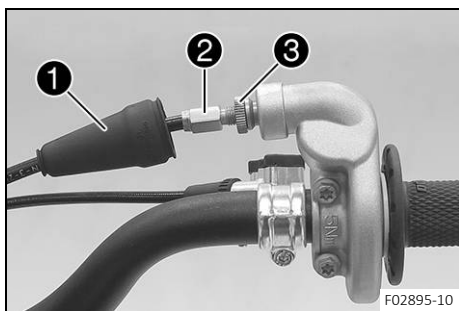

- Turn barrel adjuster **2** so that there is play **A** in the throttle cable at the throttle grip.

Guideline

Play in throttle cable	3 ... 5 mm (0.12 ... 0.2 in)
------------------------	------------------------------

- Tighten nut **3**.
- Slide on sleeve **1**.

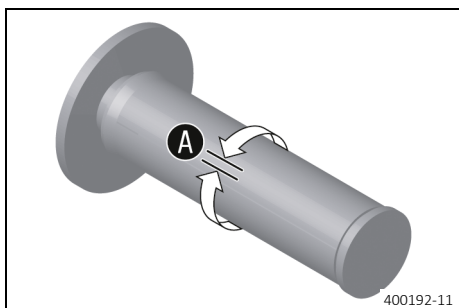

Finishing work

- Install the fuel tank. (🔧 p. 51)
- Mount the seat. (🔧 p. 57)
- Check the play in the throttle cable. (🔧 p. 94)



16.3 Carburettor – idle speed

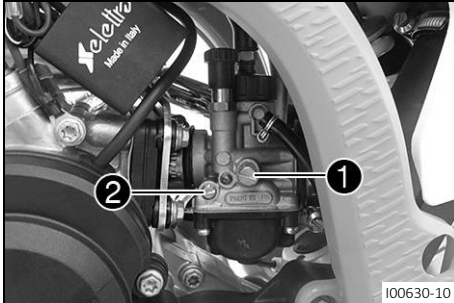

The idle setting of the carburetor has a big influence on the starting behavior, stable idle speed, and the response to throttle opening. This means that an engine with a correctly set idle speed will be easier to start than one with an incorrectly set idle speed.

i Info
The carburetor and its components are subject to increased wear caused by engine vibration. Wear can result in malfunctioning.

The idle speed is adjusted using the idle speed adjusting screw **1**.
The idle mixture is adjusted using the idle air adjusting screw **2**.

16.4 Carburetor – adjusting the idle speed

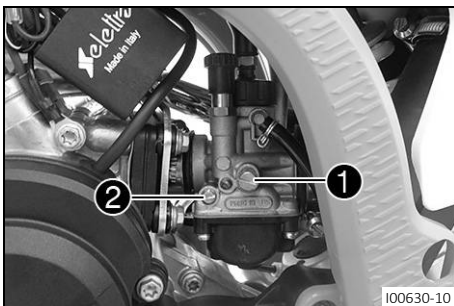

- Screw in idle air adjusting screw **2** all the way and turn it to the specified basic setting.

Guideline

Idle air adjusting screw	
Open	3 turns

- Run the engine until warm.

Guideline

Warming-up phase	≥ 5 min
------------------	---------

- Connect the special tool.

Service hour counter with revolution counter (A54012920100)

! Danger
Danger of poisoning Exhaust gases are toxic and inhaling them may result in unconsciousness and death.

- Always make sure there is sufficient ventilation when running the engine.
- Use effective exhaust extraction when starting or running the engine in an enclosed space.

- Adjust the idle speed using idle speed adjusting screw **1**.

Guideline

Choke function deactivated – The choke lever is pushed in to the stop. (🔧 p. 16)	
Idle speed	1,700 ... 2,000 rpm

- Turn idle air adjusting screw **2** slowly in a clockwise direction until the idle speed begins to fall.
- Note the position and turn the idle air adjusting screw slowly counterclockwise until the idle speed again begins to fall.

- Adjust to the point between these two positions with the highest idle speed.

i Info

If there is a big engine speed rise, reduce the idle speed to a normal level and repeat the above steps.

If the procedure described here does not lead to satisfactory results, the cause may be a wrongly dimensioned idling jet. If you can turn the idle air adjusting screw to the end without any change of engine speed, mount a smaller idling jet. After changing the idling jet, start from the beginning with the adjusting steps.

Following extreme air temperature or altitude changes, adjust the idle speed again.

16.5 Checking the clutch setting



- Connect special tool **1**.

Service hour counter with revolution counter (A54012920100)

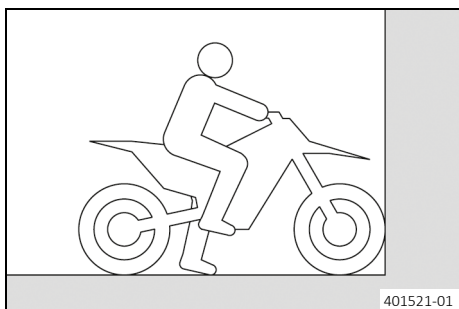

- Let the front wheel of the vehicle make contact with a fixed object.



Danger

Danger of poisoning Exhaust gases are toxic and inhaling them may result in unconsciousness and death.

- Always make sure there is sufficient ventilation when running the engine.
- Use effective exhaust extraction when starting or running the engine in an enclosed space.

- Start the motorcycle.
- Only ride full throttle to the point where the maximum engine speed is reached.

Guideline

Operation at full throttle	≤ 3 s
----------------------------	-------

- Read the speed.

Slip speed	9,800 ... 10,400 rpm
------------	----------------------

» If the specified value is not reached:

- Adjust the clutch. (p. 97)

16.6 Removing the clutch cover



Note

Environmental hazard Improper handling of fuel is a danger to the environment.

- Do not allow fuel to enter the groundwater, the soil, or the sewage system.



Info

Fuel can emerge via the carburetor.
Capture emerging fuel using a suitable container.

- Turn the knurled screw on the fuel tap all the way clockwise.
- Lay the vehicle down on its left side.
- Remove screws ①.
- Remove clutch cover ② with the seal ring.

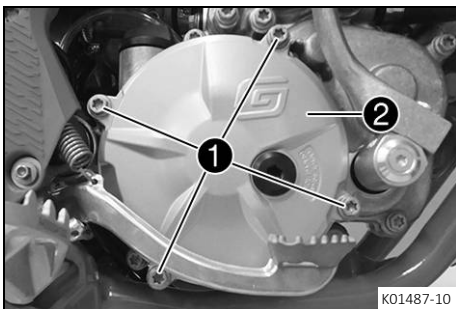

16.7 Adjusting the clutch

Preparatory work

Condition

Clutch cover remains fitted

- Raise the motorcycle with a lift stand. (📖 p. 42)

Condition

Clutch cover is removed

- Remove the clutch cover. (🔧📖 p. 97)

Condition

Clutch cover remains fitted

- Remove plug ① and the seal ring.

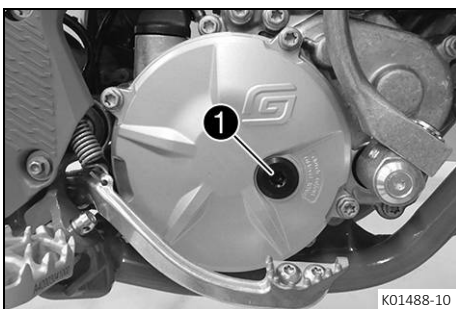

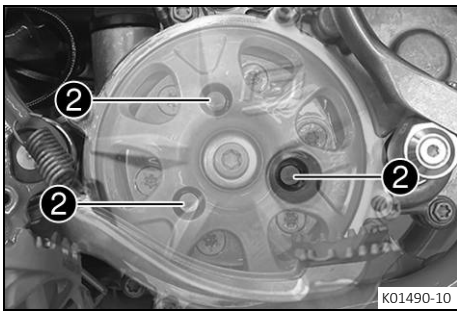
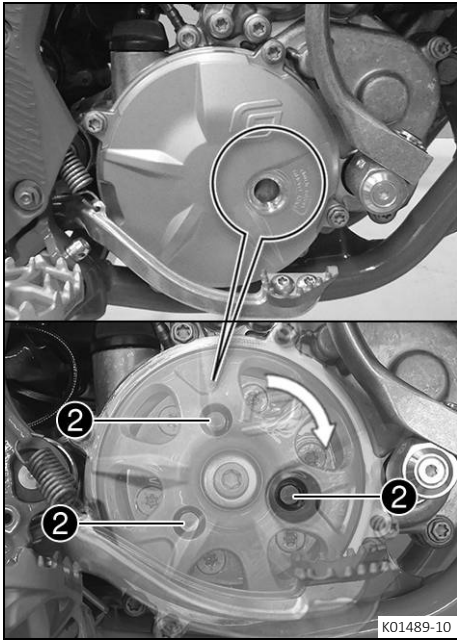

- Turn the clutch basket until adjusting screws ② become accessible.

i Info
The clutch basket is turned with the kick starter lever.
Adjusting screws ② are turned with the rear wheel.

Condition

If there is no reference point:

- Turn adjusting screws ② counterclockwise to the last detectable click.
- Turn adjusting screws ② clockwise by 8 clicks to the basic setting.

Guideline

Basic setting of slip speed	9,800 ... 10,400 rpm
-----------------------------	----------------------

i Info
The springs may not be pretensioned by more than 14 clicks from the stop using the adjusting screws. If 15 clicks or more are preloaded, the clutch can become tense and can no longer be reset. The clutch must be dismantled.

Condition

If the slip speed is too low:

- Turn adjusting screws ② clockwise.

Guideline

1 click increases the slip speed by	200 ... 300 rpm
-------------------------------------	-----------------

i Info
The springs may not be pretensioned by more than 14 clicks from the stop using the adjusting screws.

Condition

If the slip speed is too high:

- Turn adjusting screws ② counterclockwise.

Guideline

1 click decreases the slip speed by	200 ... 300 rpm
-------------------------------------	-----------------

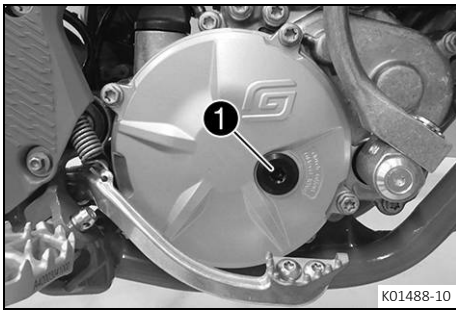

K01488-10

- Mount and tighten plug **1** with a new seal ring.

Guideline

Screw, gear oil level monitoring	M14x1.25	10 Nm (7.4 lbf ft)
----------------------------------	----------	--------------------

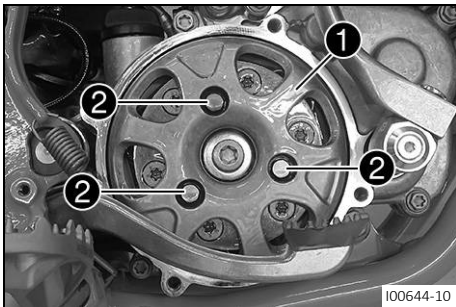

I00644-10

Condition

Clutch cover is removed

- Turn clutch basket **1** until adjusting screws **2** become accessible.

i Info

Clutch basket **1** is turned with the kick starter lever. Adjusting screws **2** are turned with the rear wheel.

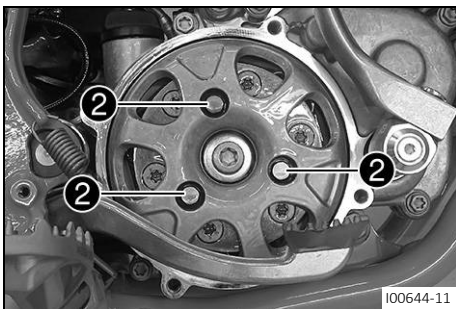

I00644-11

Condition

If there is no reference point:

- Turn adjusting screws **2** counterclockwise to the last detectable click.
- Turn adjusting screws **2** clockwise by 8 clicks to the basic setting.

Guideline

Basic setting of slip speed	9,800 ... 10,400 rpm
-----------------------------	----------------------

i Info

The springs may not be pretensioned by more than 14 clicks from the stop using the adjusting screws. If 15 clicks or more are preloaded, the clutch can become tense and can no longer be reset. The clutch must be dismantled.

Condition

If the slip speed is too low:

- Turn adjusting screws **2** clockwise.

Guideline

1 click increases the slip speed by	200 ... 300 rpm
-------------------------------------	-----------------

i Info

The springs may not be pretensioned by more than 14 clicks from the stop using the adjusting screws.

Condition

If the slip speed is too high:

- Turn adjusting screws **2** counterclockwise.

Guideline

1 click decreases the slip speed by	200 ... 300 rpm
-------------------------------------	-----------------

Finishing work

Condition

Clutch cover remains fitted

- Remove the motorcycle from the lift stand. (📖 p. 42)

Condition

Clutch cover is removed

- Install the clutch cover. 🛠️ (📖 p. 100)
- Check the gear oil level. (📖 p. 101)
- Check the clutch setting. 🛠️ (📖 p. 96)

16.8 Installing the clutch cover 🛠️

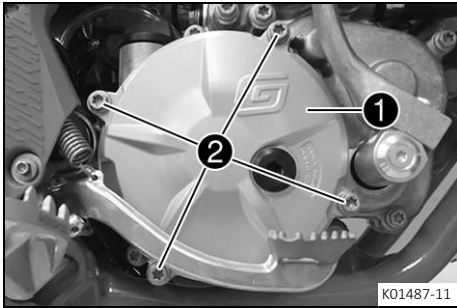

Main work

- Position the clutch cover **1** with the seal ring.
- Mount and tighten screws **2**.

Guideline

Screw, outer clutch cover	M6	10 Nm (7.4 lbf ft)
---------------------------	----	--------------------

Finishing work

- Check the gear oil level. (📖 p. 101)

17.1 Checking the gear oil level

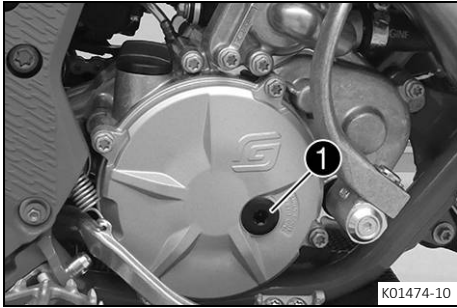

Condition

The engine is cold.

Preparatory work

- Stand the motorcycle upright on a horizontal surface.

Main work

- Remove screw ①.
- Check the gear oil level.

Gear oil must not run out of the hole.

The gear oil level is at the lower edge of the hole.

- » If the gear oil level is below the hole:
 - Add the gear oil. 🛠️ (p. 102)
- » If gear oil runs out:
 - Correct the gear oil level.

- Mount and tighten screw ①.

Guideline

Screw, gear oil level monitoring	M14x1.25	10 Nm (7.4 lbf ft)
----------------------------------	----------	--------------------



17.2 Changing the gear oil 🛠️



Warning

Danger of scalding Engine and gear oil get hot when the motorcycle is operated.

- Wear suitable protective clothing and safety gloves.
- In the event of scalding, rinse the area affected immediately with lukewarm water.



Note

Environmental hazard Hazardous substances cause environmental damage.

- Dispose of oils, grease, filters, fuel, cleaning agents, brake fluid, etc., correctly and in compliance with the applicable regulations.



Info

Drain gear oil with engine at operating temperature.

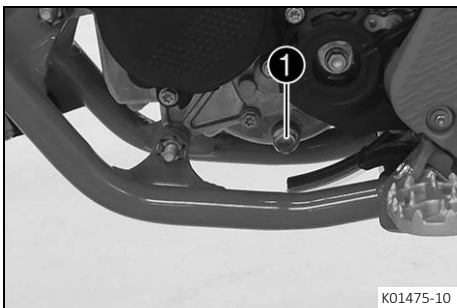

Preparatory work

- Stand the motorcycle on the plug-in stand on a horizontal surface.

Main work

- Position an appropriate container under the engine.
- Remove oil drain plug ① with the magnet.
- Let the gear oil drain fully.
- Thoroughly clean the oil drain plug with magnet.
- Clean the sealing surface on the engine.
- Mount and tighten the oil drain plug with the magnet and new seal ring.

Guideline

Oil drain plug with magnet	M12x1.5	20 Nm (14.8 lbf ft)
----------------------------	---------	---------------------

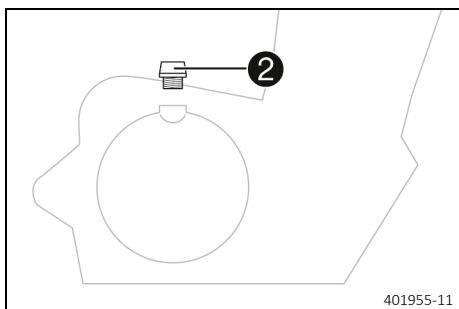

- Remove filler plug ② with the O-ring, and fill up with gear oil.

Gear oil	0.20 l (0.21 qt.)	Gear oil (ATF Dexron 3) (📖 p. 123)
----------	-------------------	------------------------------------



Info

Too little gear oil or poor-quality gear oil results in premature wear to the transmission.

- Mount and tighten filler plug ② together with the O-ring.



Danger

Danger of poisoning Exhaust gases are toxic and inhaling them may result in unconsciousness and death.

- Always make sure there is sufficient ventilation when running the engine.
- Use effective exhaust extraction when starting or running the engine in an enclosed space.

- Start the engine and check it for leaks.

Finishing work

- Check the gear oil level. (📖 p. 101)

17.3 Adding the gear oil 🛠️



Info

Too little gear oil or poor-quality gear oil results in premature wear to the transmission.

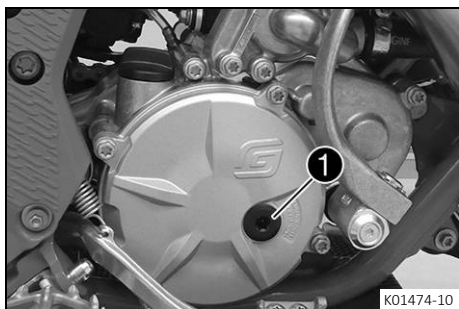

Preparatory work

- Stand the motorcycle upright on a horizontal surface.

Main work

- Remove screw ①.

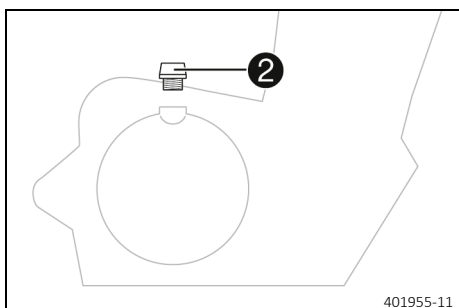

- Remove filler plug ② with the O-ring.
- Add gear oil until it flows out of the hole of the gear oil level plug.

Gear oil (ATF Dexron 3) (📖 p. 123)

- Mount and tighten screw ①.

Guideline

Screw, gear oil level monitoring	M14x1.25	10 Nm (7.4 lbf ft)
----------------------------------	----------	--------------------

- Mount and tighten filler plug ② together with the O-ring.

**Danger**

Danger of poisoning Exhaust gases are toxic and inhaling them may result in unconsciousness and death.

- Always make sure there is sufficient ventilation when running the engine.
- Use effective exhaust extraction when starting or running the engine in an enclosed space.

- Start the engine and check it for leaks.



18.1 Removing the carburetor 🛠️



Danger

Fire hazard Fuel is highly flammable.

The fuel in the fuel tank expands when warm and can escape if overfilled.

- Do not fuel the vehicle in the vicinity of open flames or lit cigarettes.
- Switch off the engine for refueling.
- Make sure that no fuel is spilled; particularly not on hot parts of the vehicle.
- If any fuel is spilled, wipe it off immediately.
- Observe the specifications for refueling.



Warning

Danger of poisoning Fuel is harmful to health.

- Avoid skin, eye and clothing contact with fuel.
- Immediately consult a doctor if you swallow fuel.
- Do not inhale fuel vapors.
- Rinse the affected area immediately with plenty of water in the event of contact with the skin.
- Rinse the eyes thoroughly with water, and consult a doctor in case of fuel contact with the eyes.
- Change your clothing if fuel spills on them.
- Keep fuels correctly in a suitable canister, and out of the reach of children.

Preparatory work

- Raise the motorcycle with a lift stand. (📖 p. 42)
- Remove the seat. (📖 p. 57)
- Turn the knurled screw on the fuel tap all the way clockwise.
- Remove the fuel tank. 🛠️ (📖 p. 50)
- Remove the right side cover. (📖 p. 55)
- Remove main silencer. (📖 p. 60)
- Remove the frame protector. (📖 p. 58)
- Remove the left side cover. (📖 p. 54)

Main work

- Loosen hose clips ① and ②.

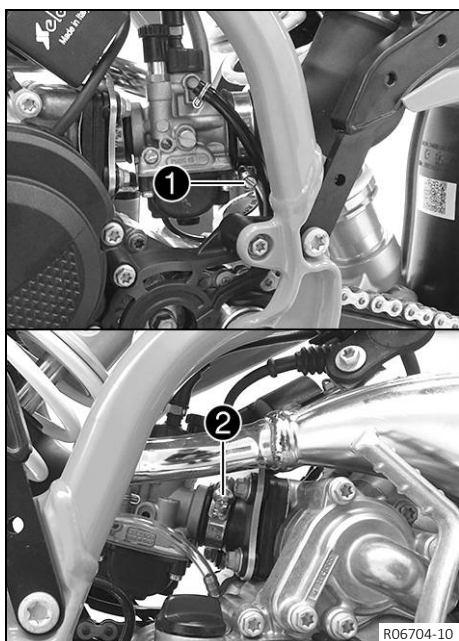

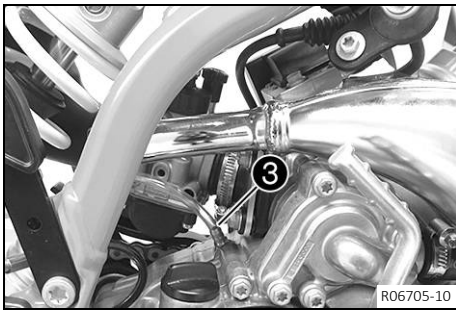

- Pull off vent hose **3**.

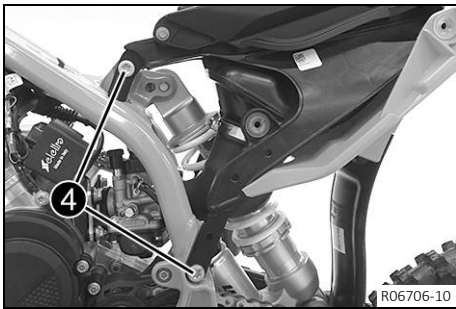

- Remove screws **4**.
- Repeat the operation on the opposite side.
- Remove subframe with the fender.

i **Info**
Watch out for the intake flange.

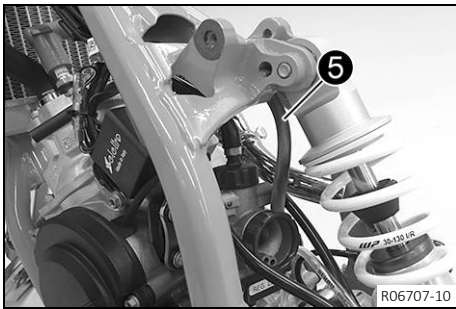

- Take fuel line **5** out of the guide.

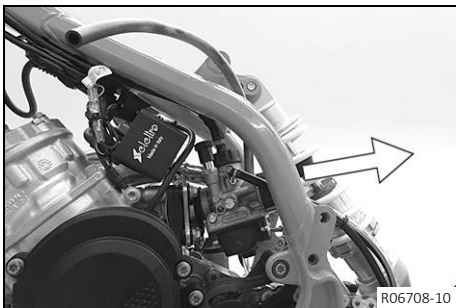

- Pull the carburetor back toward the rear.

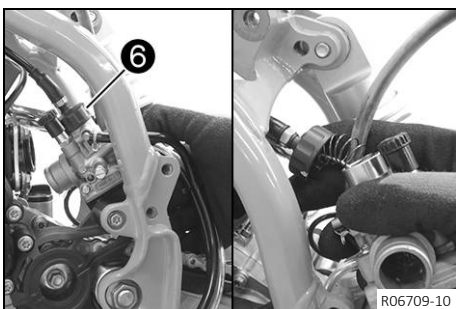

- Open throttle slide cover **6**.
- Pull the throttle slide out of the carburetor.
- Drain the remaining fuel.

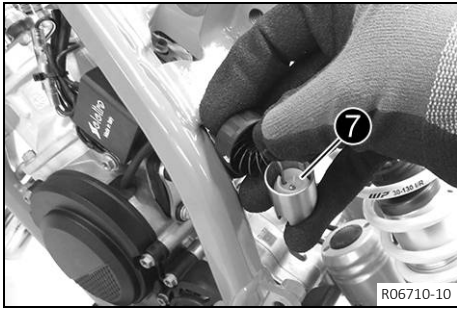

- Pull throttle slide spring back.
- Push spring retainer **7** back.

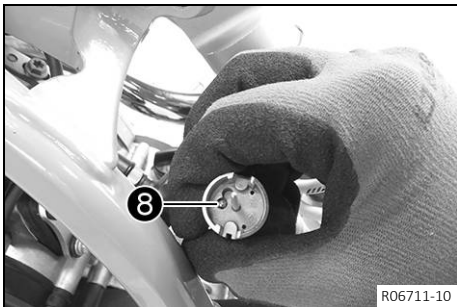

- Detach throttle cable wire **8**.
- Take off the throttle slide.

18.2 Installing the carburetor

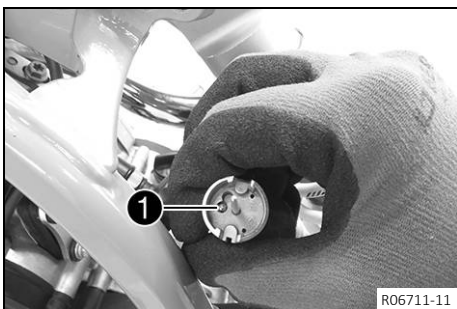

Main work

- Attach throttle cable wire **1**.



- Position spring retainer **2** and the throttle slide spring.



- Position the throttle slide and the throttle slide cover.
- Tighten throttle slide cover **3** hand-tight.
- Measure the distance between the carburetor housing and the throttle slide cover.
 - » Distance: $\leq 3 \text{ mm}$ ($\leq 0.12 \text{ in}$)
 - If the specified value is not reached:
 - Screw on the throttle slide cover correctly.

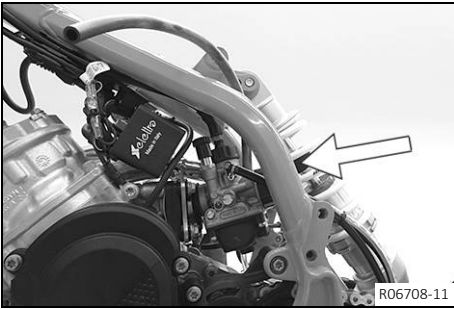

- Mount the carburetor.

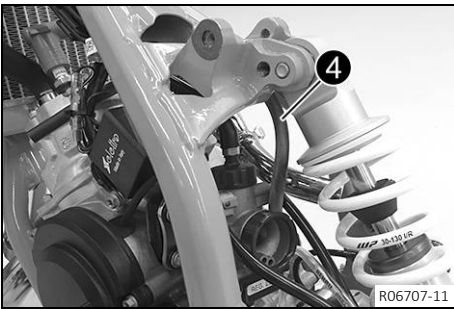

- Position fuel hose ④ in the guide.

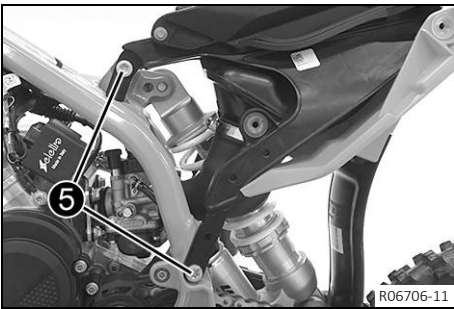

- Position the subframe.

i Info
Watch out for the intake flange.

- Mount and tighten screws ⑤.

Guideline

Remaining screws, chassis	M8	25 Nm (18.4 lbf ft)
------------------------------	----	---------------------

- Repeat the operation on the opposite side.

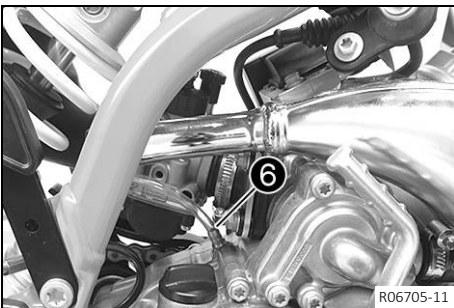

- Mount vent hose ⑥.

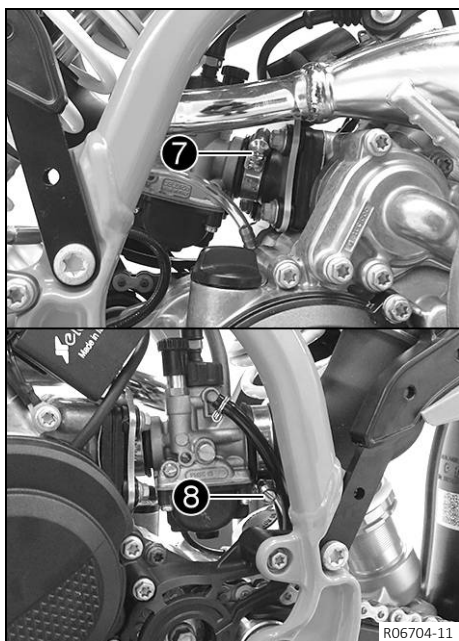

- Position and tighten hose clips **7** and **8**.

Guideline

Hose clip, carburetor	-	2.8 Nm (2.07 lbf ft)
-----------------------	---	----------------------

Finishing work

- Check the play in the throttle cable. (📖 p. 94)
- Install the main silencer. (📖 p. 61)
- Install the left side cover. (📖 p. 55)
- Carburetor – adjust the idle speed. 🛠️ (📖 p. 95)
- Install the frame protector. (📖 p. 58)
- Install the fuel tank. 🛠️ (📖 p. 51)
- Mount the seat. (📖 p. 57)
- Remove the motorcycle from the lift stand. (📖 p. 42)

19.1 Cleaning the motorcycle

Note

Material damage Components become damaged or destroyed if a pressure cleaner is used incorrectly.

The high pressure forces water into the electrical components, connectors, throttle cables, and bearings, etc. Pressure which is too high causes malfunctions and destroys components.

- Do not direct the water jet directly on to electrical components, connectors, throttle cables or bearings.
- Maintain a minimum distance between the nozzle of the pressure cleaner and the component.
Minimum clearance 60 cm (23.6 in)



Note

Environmental hazard Hazardous substances cause environmental damage.

- Dispose of oils, grease, filters, fuel, cleaning agents, brake fluid, etc., correctly and in compliance with the applicable regulations.



Info

Clean the motorcycle regularly to maintain its value and appearance over a long period. Avoid direct sunshine when cleaning the motorcycle.

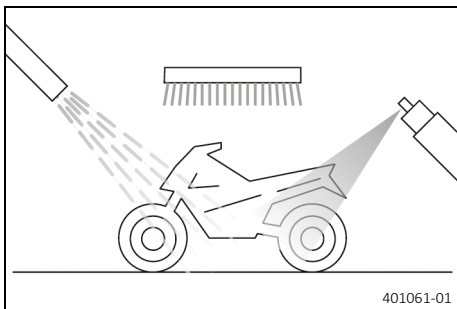

- Close off exhaust system to keep water from entering.
- Remove loose dirt first with a soft jet of water.
- Spray the heavily soiled parts with a normal commercial motorcycle cleaner and clean using a brush.

Motorcycle cleaner (📖 p. 124)



Info

Use warm water containing normal motorcycle cleaner and a soft sponge. Never apply motorcycle cleaner to a dry vehicle; always rinse the vehicle with water first.

- After rinsing the motorcycle with a gentle spray of water, allow it to dry thoroughly.
- Remove the closure of the exhaust system.
- Empty the carburetor float chamber. 🛠️



Warning

Danger of accidents Moisture and dirt impair the brake system.

- Explain to your child that he or she must brake carefully several times to dry out and remove dirt from the brake linings and the brake discs.

- After cleaning, your child should ride the vehicle a short distance until the engine warms up and until the brakes system has dried through careful application of the brakes.



Info

The heat produced causes water at inaccessible locations in the engine and on the brake system to evaporate.

- Push back the protection caps on the handlebar controls to allow water to evaporate.

- After the motorcycle has cooled down, lubricate all moving parts and pivot points.
- Clean the chain. (📖 p. 63)
- Treat bare metal (except for brake discs and the exhaust system) with a corrosion inhibitor.

Preserving materials for paints, metal and rubber (📖 p. 124)

- Treat all plastic parts and powder-coated parts with a mild cleaning and care product.

Special cleaner for glossy and matte paint finishes, metal and plastic surfaces (📖 p. 124)

20.1 Storage



Warning

Danger of poisoning Fuel is harmful to health.

- Avoid skin, eye and clothing contact with fuel.
- Immediately consult a doctor if you swallow fuel.
- Do not inhale fuel vapors.
- Rinse the affected area immediately with plenty of water in the event of contact with the skin.
- Rinse the eyes thoroughly with water, and consult a doctor in case of fuel contact with the eyes.
- Change your clothing if fuel spills on them.
- Keep fuels correctly in a suitable canister, and out of the reach of children.



Info

If the motorcycle is not being used for an extended length of time, additional measures are recommended. Before storing the motorcycle, check all parts for function and wear. If service, repairs, or replacements are necessary, you should do this during the storage period (less workshop overload). This allows you to avoid long waiting periods when the next season starts.

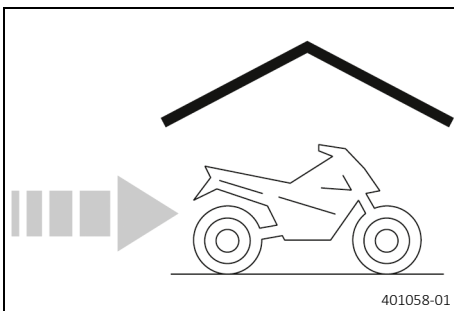

- When refueling for the last time before taking the motorcycle out of service, add fuel additive.

Fuel additive (📖 p. 124)

- Refuel. (📖 p. 23)



Tip

Fill the fuel tank completely as specified, using fuel with the lowest possible ethanol content.

- Clean the motorcycle. (📖 p. 109)
- Change the gear oil. 🛠️ (📖 p. 101)
- Check the antifreeze and coolant level. (📖 p. 89)
- Empty the carburetor float chamber. 🛠️
- Check tire pressure. (📖 p. 87)
- Store the vehicle in a dry location that is not subject to large fluctuations in temperature.



Info

GASGAS recommends jacking up the motorcycle.

- Raise the motorcycle with a lift stand. (📖 p. 42)
- Cover the motorcycle with a tarp or cover that is permeable to air.



Info

Do not use non-porous materials since they prevent humidity from escaping, thus causing corrosion.

Avoid running the engine for a short time only. Because the engine will not warm up sufficiently, the water vapor produced during combustion will condense, causing engine parts and the exhaust system to rust.

20.2 Preparing for use after storage

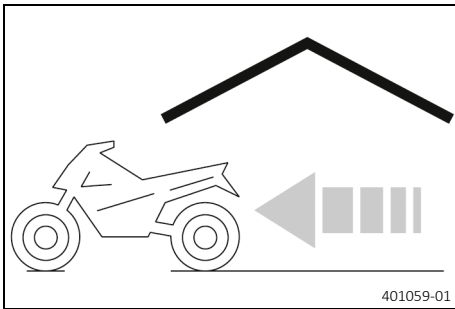

- Remove the motorcycle from the lift stand. (📖 p. 42)
- Perform checks and maintenance measures when preparing for use. (📖 p. 20)
- Take a test ride.

Faults	Possible cause	Action
Engine turns but does not start	Operating error	– Carry out start procedure. (📖 p. 20)
	Motorcycle was out of use for a long time and there is old fuel in the float chamber	– Empty the carburetor float chamber. 🛠️
	Fuel supply interrupted	– Check the fuel tank breather. – Clean the fuel tap. – Check/set the carburetor components. 🛠️
	Spark plug sooty or wet	– Clean and dry the spark plug and spark plug connector, or change if necessary.
	Plug gap of spark plug too wide	– Adjust plug gap. Guideline Spark plug electrode gap 0.70 mm (0.0276 in)
	Fault in ignition system	– Check the ignition system. 🛠️
	Short-circuit cable in wiring harness frayed, stop button faulty	– Check the stop button. 🛠️
	The connector or ignition coil is loose or oxidized	– Clean the plug-in connection and treat it with contact spray.
Engine has no idle speed	Water in carburetor or jets blocked	– Check/set the carburetor components. 🛠️
	Idling jet blocked	– Check/set the carburetor components. 🛠️
	Adjusting screws on the carburetor are in turned to the wrong position	– Carburetor – adjust the idle speed. 🛠️ (📖 p. 95)
	Spark plug defective	– Change spark plug.
Engine does not speed up	Ignition system defective	– Check the ignition coil. 🛠️ – Check the spark plug connector. 🛠️
	The carburetor is flowing over because the float needle is dirty or worn	– Check/set the carburetor components. 🛠️
	Loose carburetor jets	– Check/set the carburetor components. 🛠️
Engine has too little power	Fault in ignition system	– Check the ignition system. 🛠️
	Fuel supply interrupted	– Check the fuel tank breather. – Clean the fuel tap. – Check/set the carburetor components. 🛠️
	Air filter very dirty	– Clean the air filter and air filter box. 🛠️ (📖 p. 59)
	Exhaust system leaky, deformed or too little glass fiber yarn filling in main silencer	– Check exhaust system for damage. – Change the rock wool on the main silencer. 🛠️ (📖 p. 61)
	Ignition system defective	– Check the ignition coil. 🛠️ – Check the spark plug connector. 🛠️
	Diaphragm or reed valve housing damaged	– Check the diaphragm and reed valve housing.
	Noticeable wear	– Overhaul the engine.
Engine stalls or is popping into the carburetor	Clutch engagement speed too low or too high	– Check the clutch setting. 🛠️ (📖 p. 96)
	Lack of fuel	– Turn the knurled screw on the fuel tap all the way counterclockwise. – Refuel. (📖 p. 23)

Faults	Possible cause	Action
Engine stalls or is popping into the carburetor	Engine takes in bad air	– Check the intake flange and carburetor for tightness.
	The connector or ignition coil is loose or oxidized	– Clean the plug-in connection and treat it with contact spray.
Engine overheats	Too little coolant in cooling system	– Check the cooling system for leakage. – Check the coolant level. (📖 p. 90)
	Too little air stream	– Switch off engine when standing.
	Radiator fins very dirty	– Clean radiator fins.
	Foam formation in cooling system	– Drain the coolant. 🛠️ (📖 p. 90) – Refill with coolant. 🛠️ (📖 p. 91)
	Damaged cylinder head or cylinder head gasket	– Check the cylinder head or cylinder head gasket.
	Bent radiator hose	– Change the radiator hose. 🛠️
White smoke emission (steam in exhaust gas)	Damaged cylinder head or cylinder head gasket	– Check the cylinder head or cylinder head gasket.
Gear oil exits at the vent hose	Too much gear oil added	– Check the gear oil level. (📖 p. 101)
Water in the gear oil	Damaged radial shaft seal ring or water pump	– Check the radial shaft seal ring and the water pump.

22.1 Engine

Design	1-cylinder 2-stroke engine, water-cooled, with reed intake
Displacement	49.9 cm ³ (3.045 cu in)
Stroke	40.7 mm (1.602 in)
Bore	39.5 mm (1.555 in)
Crankshaft bearing	2 grooved ball bearings
Conrod bearing	Needle bearing
Piston pin bearing	Needle bearing
Pistons	Aluminum cast
Piston rings	1 rectangular ring
Engine lubrication	Mixed lubrication
Primary transmission	33:61 straight cut spur gear drive
Clutch	Multi-disc centrifugal force clutch
Gearbox	Rigid 1-stage reduction gear
Transmission ratio	14:31
Ignition	Selettra Digital
Spark plug	BRISK AR10C (Standard), BRISK AR10IR (recommended for competition use)
Spark plug electrode gap	0.70 mm (0.0276 in)
Cooling	Water-cooled
Starting aid	Kick starter system

22.2 Engine tightening torques

Nut, water pump impeller	M5	5 Nm (3.7 lbf ft)	Loctite®243™
Screw, bearing retainer	M5	5 Nm (3.7 lbf ft)	Loctite®243™
Screw, kick starter lever	M5	6 Nm (4.4 lbf ft)	Loctite®243™
Screw, stator bracket	M5	6 Nm (4.4 lbf ft)	Loctite®243™
Air release screw for coolant	M6	8 Nm (5.9 lbf ft)	
Drain plug, water pump cover	M6	6 Nm (4.4 lbf ft)	
Screw, alternator cover	M6	6 Nm (4.4 lbf ft)	
Screw, cylinder head	M6x25	10 Nm (7.4 lbf ft)	
Screw, engine case	M6	10 Nm (7.4 lbf ft)	
Screw, engine sprocket	M6	10 Nm (7.4 lbf ft)	Loctite®2701™
Screw, exhaust flange	M6	10 Nm (7.4 lbf ft)	Loctite®243™
Screw, fitting pin	M6	10 Nm (7.4 lbf ft)	Loctite®2701™
Screw, ground wire	M6	10 Nm (7.4 lbf ft)	
Screw, ignition coil	M6	8 Nm (5.9 lbf ft)	Loctite®243™
Screw, inner clutch cover	M6	10 Nm (7.4 lbf ft)	
Screw, intake flange	M6	5 Nm (3.7 lbf ft)	Loctite®243™

Screw, outer clutch cover	M6	10 Nm (7.4 lbf ft)
Screw, pressure plate	M6	10 Nm (7.4 lbf ft) Loctite®243™
Screw, water pump cover	M6	10 Nm (7.4 lbf ft)
Vacuum connection (housing breather)	M6	4 Nm (3 lbf ft) Loctite®243™
Nuts, cylinder base	M8	20 Nm (14.8 lbf ft)
Screw, clutch basket	M8	35 Nm (25.8 lbf ft) Loctite®243™
Screw, cylinder base	M8x41	7 Nm (5.2 lbf ft)
Spark plug	M10x1	13 Nm (9.6 lbf ft)
Nut, primary gear wheel	M10x1.25	40 Nm (29.5 lbf ft) Loctite®243™
Nut, rotor	M10x1.25	15 Nm (11.1 lbf ft) Loctite®243™
Oil drain plug with magnet	M12x1.5	20 Nm (14.8 lbf ft)
Screw, gear oil level monitoring	M14x1.25	10 Nm (7.4 lbf ft)

22.3 Carburetor with carburetor tuning

Carburetor type	Dell'Orto PHBG 19BS
Needle position	2nd position from top
Idle air adjusting screw	
Open	3 turns
Main jet	88 (85, 90, 92)
Jet needle	W7
Idling jet	50
Needle jet	262AU
Throttle slide	40
Choke nozzle	65

22.3.1 Carburetor tuning (Option: Low seat position)

Dell'Orto PHBG19 BS

ASL	TEMP	-20 ... -7 °C (-4 ... 19 °F)	-6 ... 5 °C (21 ... 41 °F)	6 ... 15 °C (43 ... 59 °F)	16 ... 24 °C (61 ... 75 °F)	25 ... 36 °C (77 ... 97 °F)	37 ... 49 °C (99 ... 120 °F)
2,301 ... 3,000 m (7,549 ... 9,843 ft)	ASO IJ NDL POS MJ	3 50 W7 2 82	3 48 W7 2 82	3 45 W7 2 82	3 48 W7 1 85	3 48 W7 1 85	
1,501 ... 2,300 m (4,925 ... 7,546 ft)	ASO IJ NDL POS MJ	3 50 W7 2 82	3 50 W7 2 82	3 48 W7 2 82	3 48 W7 2 82	3 48 W7 2 85	3 48 W7 2 88
751 ... 1,500 m (2,464 ... 4,921 ft)	ASO IJ NDL POS MJ	3 52 W7 2 88	3 50 W7 2 85	3 50 W7 2 85	3 50 W7 2 85	3 50 W7 2 88	3 50 W7 2 90

ASL	TEMP	-20 ... -7 °C (-4 ... 19 °F)	-6 ... 5 °C (21 ... 41 °F)	6 ... 15 °C (43 ... 59 °F)	16 ... 24 °C (61 ... 75 °F)	25 ... 36 °C (77 ... 97 °F)	37 ... 49 °C (99 ... 120 °F)
301 ... 750 m (988 ... 2,461 ft)	ASO	3	3	3	3	3	3
	IJ	55	52	50	50	50	50
	NDL	W7	W7	W7	W7	W7	W7
	POS	2	2	2	2	2	2
	MJ	88	88	88	88	90	92
0 ... 300 m (0 ... 984 ft)	ASO	3	3	3	3	3	3
	IJ	55	52	50	50	50	50
	NDL	W7	W7	W7	W7	W7	W7
	POS	2	2	2	2	2	2
	MJ	90	90	90	90	92	95

M/FT ASL	Above sea level
TEMP	Temperature
ASO	Open (rotations) idle air adjusting screw
IJ	Idling jet
NDL	Jet needle
POS	Needle position from top
MJ	Main jet

The carburetor tuning depends on the defined ambient and operating conditions.

22.3.2 Carburetor tuning (Option: High seat position)

Dell'Orto PHBG19 BS

ASL	TEMP	-20 ... -7 °C (-4 ... 19 °F)	-6 ... 5 °C (21 ... 41 °F)	6 ... 15 °C (43 ... 59 °F)	16 ... 24 °C (61 ... 75 °F)	25 ... 36 °C (77 ... 97 °F)	37 ... 49 °C (99 ... 120 °F)
2,301 ... 3,000 m (7,549 ... 9,843 ft)	ASO	3	3	3	3	3	
	IJ	50	48	45	48	48	
	NDL	W7	W7	W7	W7	W7	
	POS	2	2	2	1	1	
	MJ	85	85	85	88	88	
1,501 ... 2,300 m (4,925 ... 7,546 ft)	ASO	3	3	3	3	3	3
	IJ	50	50	48	48	48	48
	NDL	W7	W7	W7	W7	W7	W7
	POS	2	2	2	2	2	2
	MJ	85	85	85	85	88	90
751 ... 1,500 m (2,464 ... 4,921 ft)	ASO	3	3	3	3	3	3
	IJ	52	50	50	50	50	50
	NDL	W7	W7	W7	W7	W7	W7
	POS	2	2	2	2	2	2
	MJ	90	88	88	88	90	92
301 ... 750 m (988 ... 2,461 ft)	ASO	3	3	3	3	3	3
	IJ	55	52	50	50	50	50
	NDL	W7	W7	W7	W7	W7	W7
	POS	2	2	2	2	2	2
	MJ	90	90	90	90	92	95
0 ... 300 m (0 ... 984 ft)	ASO	3	3	3	3	3	3
	IJ	55	52	50	50	50	50
	NDL	W7	W7	W7	W7	W7	W7
	POS	2	2	2	2	2	2
	MJ	92	92	92	92	95	98

M/FT ASL	Above sea level
TEMP	Temperature
ASO	Open (rotations) idle air adjusting screw
IJ	Idling jet
NDL	Jet needle
POS	Needle position from top
MJ	Main jet

The carburetor tuning depends on the defined ambient and operating conditions.

22.4 Capacities

22.4.1 Gear oil

Gear oil	0.20 l (0.21 qt.)	Gear oil (ATF Dexron 3) (📖 p. 123)
----------	-------------------	------------------------------------

22.4.2 Coolant

Coolant	0.7 l (0.7 qt.)	Coolant (📖 p. 122)
---------	-----------------	--------------------

22.4.3 Fuel

Fuel tank capacity, approx.	2.3 l (2.4 qt.)	Super unleaded (95 octane) mixed with 2-stroke engine oil (1:60) (📖 p. 123)
-----------------------------	-----------------	---

22.5 Chassis



Frame	Central tube frame of chrome molybdenum steel tubing, powder-coated	
Fork	WP XACT	
Shock absorber	WP XACT Mono Shock	
Suspension travel		
Front	200.6 mm (7.898 in)	
Rear	190.5 mm (7.5 in)	
Fork offset	22 mm (0.87 in)	
Brake system		
front	Disc brake with 4-piston brake caliper	
rear	Disc brake with 2-piston brake caliper	
Brake disc diameters		
front	160 mm (6.3 in)	
rear	160 mm (6.3 in)	
Brake discs - wear limits		
front	2.2 mm (0.087 in)	
rear	2.2 mm (0.087 in)	
Offroad tire pressure		
front	1.0 bar (15 psi)	
rear	1.0 bar (15 psi)	
Secondary drive ratio	11:40	
Chain	1/2 x 3/16"	
Rear sprockets available	38, 39, 40, 41, 42	
Steering head angle	66°	

Wheelbase	1,023.5 ... 1,035.6 mm (40.295 ... 40.772 in)
Seat height unloaded	634 ... 683 mm (24.96 ... 26.89 in)
Ground clearance unloaded	210 ... 227.3 mm (8.27 ... 8.949 in)
Weight without fuel approx.	42.4 kg (93.5 lb.)
Maximum rider weight	45 kg (99 lb.)

22.6 Tires

Front tire	Rear tire
60/100 - 12 36J TT MAXXIS MAXXCROSS MX-ST+	2.75 - 10 38J TT MAXXIS MAXXCROSS MX-ST+
The tires specified represent one of the possible series production tires. For alternative manufacturers, if any, contact an authorized dealer or qualified tire dealership. If local road approval regulations apply, these and the respective technical specifications must be observed. Additional information is available in the Service section under: http://www.gasgas.com	

22.7 Fork

Fork article number	07.18.6U.02	
Fork	WP XACT	
Rebound damping		
Comfort	15 clicks	
Standard	12 clicks	
Sport	10 clicks	
Air pressure	2 bar (29 psi)	
Fork length	685 mm (26.97 in)	
Spring length with preload spacer(s)	337.5 mm (13.287 in)	
Oil capacity external mechanism left	25 ± 5 ml (0.85 ± 0.17 fl. oz.)	Fork oil (SAE 4) (48601166S1) ( p. 122)
Oil capacity, right cartridge	225 ml (7.61 fl. oz.)	Fork oil (SAE 4) (48601166S1) ( p. 122)
Grease capacity, left cartridge	6 g (0.21 oz)	Special grease (00062010053) ( p. 125)

22.8 Shock absorber

Shock absorber article number	A400C402X113000	
Shock absorber	WP XACT Mono Shock	
Low-speed compression damping		
Comfort	18 clicks	
Standard	15 clicks	
Sport	12 clicks	
High-speed compression damping		
Comfort	2.5 turns	
Standard	2 turns	
Sport	1.5 turns	
Rebound damping		
Comfort	18 clicks	
Standard	15 clicks	

Sport	12 clicks
Spring preload	5 mm (0.2 in)
Spring rate	
Weight of rider: 15 ... 25 kg (33 ... 55 lb.)	25 N/mm (143 lb/in)
Weight of rider (standard): 25 ... 35 kg (55 ... 77 lb.)	30 N/mm (171 lb/in)
Weight of rider: 35 ... 45 kg (77 ... 99 lb.)	35 N/mm (200 lb/in)
Spring length	130 mm (5.12 in)
Gas pressure	10 bar (145 psi)
Static sag	30 mm (1.18 in)
Rider sag	80 mm (3.15 in)
Fitted length	275 mm (10.83 in)
Shock absorber oil	Shock absorber fluid (SAE 2.5) (50180751S1) ( p. 123)

22.9 Chassis tightening torques

Hose clip, carburetor	-	2.8 Nm (2.07 lbf ft)
Remaining EJOT PT screws	EJOT PT K60x20	2 Nm (1.5 lbf ft)
Screw, brake hose bracket	EJOT PT K60x20-Z	2 Nm (1.5 lbf ft)
Stop button screw	M3	0.4 Nm (0.3 lbf ft)
Screw, seat thrust bearing quick release	EJOT PT 35x16 M3.5	0.75 Nm (0.553 lbf ft)
Spoke nipple	M3.5	3 Nm (2.2 lbf ft)
Screw, fixed grip	M4	5 Nm (3.7 lbf ft)
		Loctite®243™
Remaining nuts, chassis	M5	5 Nm (3.7 lbf ft)
Remaining screws, chassis	M5	5 Nm (3.7 lbf ft)
Screw, brake assembly	M5	5 Nm (3.7 lbf ft)
Screw, brake linings	M5	8 Nm (5.9 lbf ft)
Brake cylinder screw on the rear brake system	M6	10 Nm (7.4 lbf ft)
		Loctite®243™
Nut, push rod ball joint on the brake cylinder of the rear brake system	M6	10 Nm (7.4 lbf ft)
Nut, push rod, foot brake lever	M6	6 Nm (4.4 lbf ft)
Remaining nuts, chassis	M6	10 Nm (7.4 lbf ft)
Remaining screws, chassis	M6	10 Nm (7.4 lbf ft)
Screw, fender	M6	6 Nm (4.4 lbf ft)
Screw, fork stub	M6	10 Nm (7.4 lbf ft)
Screw, front brake disc	M6	14 Nm (10.3 lbf ft)
		Loctite®243™
Screw, main silencer silent block	M6	6 Nm (4.4 lbf ft)
Screw, radiator on frame	M6	10 Nm (7.4 lbf ft)
Screw, rear brake caliper	M6x16	10 Nm (7.4 lbf ft)
		Loctite®243™
Screw, rear brake caliper	M6x40	10 Nm (7.4 lbf ft)
		Loctite®243™
Screw, rear brake disc	M6	14 Nm (10.3 lbf ft)
		Loctite®243™
Screw, rear engine sprocket cover	M6x12	8 Nm (5.9 lbf ft)

Screw, rear mounting	M6	4 Nm (3 lbf ft)	
Screw, splash protector	M6	7 Nm (5.2 lbf ft)	
Screw, start number plate	M6	4 Nm (3 lbf ft)	
Screw, throttle grip	M6	4.5 Nm (3.32 lbf ft)	
Bushing, foot brake lever stop	M8	20 Nm (14.8 lbf ft)	
Nut, foot brake lever	M8	22 Nm (16.2 lbf ft)	
Nut, rim lock	M8	10 Nm (7.4 lbf ft)	
Remaining nuts, chassis	M8	25 Nm (18.4 lbf ft)	
Remaining screws, chassis	M8	25 Nm (18.4 lbf ft)	
Screw, bottom triple clamp	M8	15 Nm (11.1 lbf ft)	
Screw, chain sliding piece	M8	15 Nm (11.1 lbf ft)	
Screw, engine bracket	M8	25 Nm (18.4 lbf ft)	Loctite®243™
Screw, front brake caliper	M8x60	20 Nm (14.8 lbf ft)	Loctite®243™
Screw, front brake caliper	M8x40	20 Nm (14.8 lbf ft)	Loctite®243™
Screw, handlebar clamp	M8	20 Nm (14.8 lbf ft)	
Screw, rear sprocket	M8	25 Nm (18.4 lbf ft)	Loctite®243™
Screw, steering stem	M8	20 Nm (14.8 lbf ft)	
Screw, tail assembly	M8	30 Nm (22.1 lbf ft)	Loctite®2701™
Screw, top triple clamp	M8	20 Nm (14.8 lbf ft)	
Remaining nuts, chassis	M10	45 Nm (33.2 lbf ft)	
Remaining screws, chassis	M10	45 Nm (33.2 lbf ft)	
Screw, bottom shock absorber	M10	45 Nm (33.2 lbf ft)	Loctite®243™
Screw, front wheel spindle	M10	40 Nm (29.5 lbf ft)	Loctite®243™
Screw, handlebar support	M10	40 Nm (29.5 lbf ft)	Loctite®243™
Screw, top shock absorber	M10	45 Nm (33.2 lbf ft)	Loctite®243™
Rear wheel spindle nut	M12x1	70 Nm (51.6 lbf ft)	
Swingarm pivot bushing	M12x1	40 Nm (29.5 lbf ft)	
Nut, steering head	M20x1.5	10 Nm (7.4 lbf ft)	

Brake fluid DOT 4 / DOT 5.1

Standard/classification

- DOT

Guideline

- Use only brake fluid that complies with the specified standard (see specifications on the container) and that exhibits the corresponding properties.

Recommended supplier

Castrol

- REACT PERFORMANCE DOT 4

MOTOREX®

- Brake Fluid DOT 5.1

Coolant

Guideline

- Only use high-grade, silicate-free coolant with corrosion inhibitor additive for aluminum motors. Low grade and unsuitable antifreeze causes corrosion, deposits and frothing.
- Do not use pure water as only coolant is able to meet the requirements needed in terms of corrosion protection and lubrication properties.
- Only use coolant that complies with the requirements stated (see specifications on the container) and that has the relevant properties.

Antifreeze protection to at least	-25 °C (-13 °F)
-----------------------------------	-----------------

The mixture ratio must be adjusted to the necessary antifreeze protection. Use distilled water if the coolant needs to be diluted.

The use of premixed coolant is recommended.

Observe the coolant manufacturer specifications for antifreeze protection, dilution and miscibility (compatibility) with other coolants.

Recommended supplier

MOTOREX®

- COOLANT M3.0

Engine oil, 2-stroke

Standard/classification

- JASO FD (📖 p. 126)

Guideline

- Only use high-grade 2-stroke engine oil from a reputable brand.

fully synthetic

Recommended supplier

MOTOREX®

- Cross Power 2T

Fork oil (SAE 4) (48601166S1)

Standard/classification

- SAE (📖 p. 126) (SAE 4)

Guideline

- Use only oils that comply with the specified standards (see specifications on the container) and that exhibit the corresponding properties.

Gear oil (ATF Dexron 3)

Standard/classification

- Dexron III (ATF Dexron 3)

Guideline

- Use only ATF gear oils that comply with the specified standards (see specifications on the container) and that possess the necessary properties.

Recommended supplier

MOTOREX®

- ATF Dexron 3

Shock absorber fluid (SAE 2.5) (50180751S1)

Standard/classification

- SAE (📖 p. 126) (SAE 2.5)

Guideline

- Use only oils that comply with the specified standards (see specifications on the container) and that exhibit the corresponding properties.

Super unleaded (ROZ 95)

Standard/classification

- DIN EN 228 (ROZ 95)

Guideline

- Only use super unleaded fuel that matches or is equivalent to the specified standard.
- Fuel with an ethanol content of up to 10% (E10 fuel) is safe to use.



Info

Do **not** use fuel containing methanol (e.g., M15, M85, M100) or more than 10% ethanol (e.g., E15, E25, E85, E100).

Super unleaded (95 octane) mixed with 2-stroke engine oil (1:60)

Standard/classification

- DIN EN 228
- JASO FD (📖 p. 126) (1:60)

Mixture ratio

1:60	Engine oil, 2-stroke (📖 p. 122) Super unleaded (ROZ 95) (📖 p. 123)
------	---

Recommended supplier

MOTOREX®

- Cross Power 2T

Air filter cleaner

Recommended supplier

MOTOREX®

- Racing Bio Dirt Remover

Chain cleaner

Recommended supplier

MOTOREX®

- Chain Clean

Fuel additive

Recommended supplier

MOTOREX®

- Fuel Stabilizer

High viscosity grease

Recommended supplier

SKF®

- LGHB 2

Long-life grease

Recommended supplier

MOTOREX®

- Bike Grease 2000

Motorcycle cleaner

Recommended supplier

MOTOREX®

- Moto Clean

Off-road chain spray

Recommended supplier

MOTOREX®

- Chainlube Offroad

Oil for foam air filter

Recommended supplier

MOTOREX®

- Racing Bio Liquid Power

Preserving materials for paints, metal and rubber

Recommended supplier

MOTOREX®

- Moto Protect

Special cleaner for glossy and matte paint finishes, metal and plastic surfaces

Recommended supplier

MOTOREX®

- Quick Cleaner

Special grease (00062010053)

Recommended supplier

Klüber Lubrication®

- Klüberfood NH1 34-401

Universal oil spray

Recommended supplier

MOTOREX®

- Joker 440 Synthetic

JASO FD

JASO FD is a classification for a 2-stroke engine oil that was specifically developed for the extreme demands of racing. Thanks to first-rate synthetic esters and specially designed additives, superb combustion is achieved even under extreme operating conditions.

SAE

The SAE viscosity classes were defined by the Society of Automotive Engineers and are used for classifying oils according to their viscosity. The viscosity describes only one property of oil and says nothing about quality.

Art. no.	Article number
ca.	circa
cf.	compare
e.g.	for example
etc.	et cetera
i.a.	inter alia
no.	number
poss.	possibly

A

Accessories	9
Air filter	
cleaning	59
installation	59
removal	58
Air filter box	
cleaning	59
Air suspension XACT 5235	27
Antifreeze	
checking	89
Article number	
fork	12
Auxiliary substances	9

B

Basic chassis setting	
rider's weight, checking with	27
Brake discs	
checking	69
Brake fluid	
adding front brake	71
adding to rear brake	78
Brake fluid level	
of the front brake, checking	70
rear brake, checking	77
Brake lining retainers	
checking the rear brake	79
of front brake, checking	72
Brake linings	
checking the rear brake	79
of front brake, checking	72
of the front brake, changing	72
of the rear brake, changing	79

C

Capacity	
coolant	91-92, 118
fuel	24, 118
gear oil	102, 118
Carburetor	
adjusting the idle speed	95
Idle speed	95
installation	106
removal	104
Chain	
checking	65
cleaning	63
Chain guide	
adjusting	67
checking	65
Chain tension	
adjusting	64

checking	63
----------------	----

Choke	16
Cleaning	109-110

Clutch	
adjusting	97
setting, checking	96

Clutch cover	
clutch cover, removing	97
installing the clutch cover	100

Coolant	
changing	92
draining	90
refilling	91

Coolant level	
checking	89-90

Cooling system	89
Customer service	9

E

Engine	
running in	19

Engine number	12
----------------------------	----

Engine sprocket	
checking	65

Engine sprocket cover	
installation	62
removing	62

Environment	8
--------------------------	---

F

Figures	9
----------------------	---

Foot brake lever	16
adjusting the basic position	76
free travel, adjusting	76
free travel, checking	75

Fork	
article number	12

Fork article number	12
----------------------------------	----

Fork legs	
air pressure, adjusting	33
bleeding	42
checking basic setting	33
dust boots, cleaning	43
installing	45
removing	45

Fork protector	
installing	44
removing	44

Frame	
checking	67

Frame label	12
--------------------------	----

Frame protector	
installation	58

removal 58

Front fender

installing 54

removing 53

Front wheel

installing 83

removing 83

Fuel tank

installation 51

removal 50

Fuel tank filler cap

closing 15

opening 14

Fuel tap 15

Fuel, oils, etc. 9

G

Gear oil

adding 102

changing 101

Gear oil level

checking 101

H

Hand brake lever 14

basic position, adjusting 69

Handlebar position 35

adjusting 35

High-speed compression damping

adjusting the shock absorber 28

I

Implied warranty 9

Intended use 6

K

Kick starter lever 16

L

Left side cover

installation 55

removal 54

Link fork

checking 67

Lower triple clamp

installing 47

removing 46

Low-speed compression damping

adjusting the shock absorber 28

M

Main silencer

changing rock wool 61

installation 61

removal 60

Manufacturer warranty 9

Misuse 6

Motorcycle

cleaning 109

from lift stand, removing 42

raising with lift stand 42

O

Owner's Manual 8

P

Play in throttle cable

adjusting 94

checking 94

Plug-in stand 16

Preparing for use

advice on preparing for first use 17

after storage 112

checks and maintenance measures when preparing for use 20

Protective clothing 7

R

Rear sprocket

checking 65

Rear wheel

installing 85

removing 84

Rebound damping

adjusting the shock absorber 29

fork, adjusting 35

Refueling

fuel 23

Rider sag

setting 32

Right side cover

installation 56

removal 55

Rubber grip

checking 68

S

Safe operation 7

Seat

mounting 57

removing 57

Seat height

adjusting on the fork 38

adjusting on the frame 39

adjusting on the shock absorber 37

adjustment options 37

Service 9

Service schedule 25-26

Shock absorber

adjusting the spring preload 31

checking riding sag 31

installation	56
removal	56
static sag, checking	30
Shock absorber article number	13
Spare parts	9
Spoke tension	
checking	87
Start number plate	
installation	53
removal	53
Starting	20
Steering head bearing	
lubricating	50
Steering head bearing play	
adjusting	49
checking	49
Stop button	14
Storage	111
T	
Technical specifications	
capacities	118
carburetor	116
chassis	118
chassis tightening torques	120
engine	115
engine tightening torques	115
fork	119
shock absorber	119
tires	119
Throttle cable routing	
checking	67
Throttle grip	14
Tire condition	
checking	86
Tire pressure	
checking	87
Transporting	23
Troubleshooting	113-114
U	
Use definition	6
V	
Vehicle identification number	12
View of vehicle	
left side	10
right	11
W	
Work rules	8



3215154en

24.09.2024



Stallhofnerstraße 3 / 5230 Mattighofen / Austria / <http://www.gasgas.com>

