

SX-E 3
SX-E 5

ART. NO. 3214831EN



Congratulations on your decision to purchase a KTM motorcycle. You are now the owner of a state-of-the-art sports vehicle that will continue to give you and your child pleasure for a long time if you maintain it properly.

We hope your child has many safe and enjoyable rides!

Enter the serial numbers of your vehicle below.

Vehicle identification number (📖 p. 14)	Dealer's stamp
Engine number (📖 p. 14)	

Read through this Owner's Manual carefully, always exercise caution when using the vehicle, and contact an authorized KTM workshop if you have any questions.

This Owner's Manual serves as a technical instruction manual, explains important safety matters, and provides an overview of the main functions. This Owner's Manual is only intended for personal use. This Owner's Manual is not intended for commercial use.

The Owner's Manual contained the latest information for this model series at the time of publication. However, minor differences due to further developments in design cannot be ruled out completely.

All specifications contained herein are non-binding. KTM Sportmotorcycle GmbH specifically reserves the right to modify or delete technical specifications, prices, colors, forms, materials, services, designs, equipment, etc., without prior notice and without specifying reasons, to adapt these to local conditions, as well as to stop production of a particular model without prior notice. KTM accepts no liability for delivery options, deviations from figures and descriptions, misprints, and other errors. The models portrayed partly contain special equipment that does not belong to the regular scope of supply.

© 2024 KTM Sportmotorcycle GmbH, Mattighofen Austria

All rights reserved

Reproduction, even in part, as well as copying of all kinds, is permitted only with the express written permission of the copyright owner.



ISO 9001(12 100 6061)

KTM applies quality assurance processes that lead to the highest possible product quality as defined in the ISO 9001 international quality management standard.

Issued by: TÜV Management Service

REG.NO. 12 100 6061

KTM Sportmotorcycle GmbH
Stallhofnerstraße 3
5230 Mattighofen, Austria

This document is valid for the following models:

SX-E 3 (F3001X5)

SX-E 5 (F3001X6)



3214831en

29.01.2024

TABLE OF CONTENTS

1	MEANS OF REPRESENTATION	5	7	MULTIFUNCTIONAL ELEMENT.....	19
1.1	Symbols used	5	7.1	Multifunctional element.....	19
1.2	Formats used.....	5	7.2	Ride mode button	19
2	SAFETY ADVICE.....	6	7.3	Ride mode display	20
2.1	Use definition – intended use.....	6	7.4	Malfunction indicator lamp	20
2.2	Misuse.....	6	7.5	Charging level indicator	20
2.3	Notes/warnings	6	7.6	Power reduction.....	21
2.4	Grades of risks.....	6	8	PREPARING FOR USE.....	22
2.5	Tampering warning.....	6	8.1	Advice on preparing for first use	22
2.6	Safe operation	7	9	RIDING INSTRUCTIONS.....	24
2.7	Fall or accident.....	8	9.1	Checks and maintenance measures when preparing for use	24
2.8	Protective clothing	8	9.2	Starting the vehicle.....	24
2.9	Work on vehicle, engine, and rechargeable lithium-ion battery	8	9.3	Starting off.....	25
2.10	Environment.....	8	9.4	Braking.....	25
2.11	Owner's Manual	9	9.5	Recuperation (SX-E 5).....	26
2.12	Fire hazard.....	9	9.6	Stop, park	26
3	IMPORTANT NOTES.....	10	9.7	Transporting.....	27
3.1	Manufacturer warranty, implied warranty.....	10	10	SERVICE SCHEDULE	28
3.2	Fuel, auxiliary substances	10	10.1	Additional information	28
3.3	Spare parts, accessories	10	10.2	Service schedule.....	28
3.4	Service	10	11	SUSPENSION SETTING.....	30
3.5	Figures	10	11.1	Checking the basic chassis setting with the rider's weight	30
3.6	Customer service.....	10	11.2	Air suspension (SX-E 5).....	30
3.7	Power supply.....	11	11.3	Compression damping of the shock absorber (SX-E 5).....	31
3.8	Operation at low temperatures.....	11	11.4	Adjusting the low-speed compression damping of the shock absorber (SX-E 5).....	31
4	VIEW OF VEHICLE	12	11.5	Adjusting the high-speed compression damping of the shock absorber (SX-E 5).....	32
4.1	View of vehicle, front left (example) ...	12	11.6	Adjusting the rebound damping of the shock absorber (SX-E 5).....	32
4.2	View of vehicle, rear right (example).....	13	11.7	Measuring the dimension of the rear wheel unloaded (SX-E 5)	33
5	SERIAL NUMBERS	14	11.8	Checking the static sag of the shock absorber (SX-E 5).....	33
5.1	Vehicle identification number.....	14	11.9	Checking the riding sag of the shock absorber (SX-E 5).....	34
5.2	Frame label	14	11.10	Adjusting the spring preload of the shock absorber 🏹.....	34
5.3	Engine number	14	11.11	Adjusting the riding sag 🏹.....	35
5.4	Fork article number.....	14	11.12	Checking the basic setting of the fork (SX-E 5)	37
5.5	Shock absorber article number	15	11.13	Adjusting the fork air pressure (SX-E 5).....	37
5.6	Battery identification number.....	15	11.14	Adjusting the rebound damping of the fork (SX-E 5).....	38
6	CONTROLS.....	16	11.15	Handlebar position.....	39
6.1	Front brake lever.....	16			
6.2	Throttle grip	16			
6.3	On/Off button	16			
6.4	Magnetic switch on handlebar	16			
6.5	Magnetic switch under the seat	17			
6.6	Rear brake lever (SX-E 3).....	17			
6.7	Foot brake lever (SX-E 5).....	18			
6.8	Plug-in stand.....	18			
6.9	Diagnostics connector	18			









11.16	Adjusting the handlebar position	39	14.2	Adjusting the basic position of the front brake lever	66
12	SEAT HEIGHT	41	14.3	Checking the brake discs	66
12.1	Seat height adjustment options	41	14.4	Checking the front brake fluid level	67
12.2	Adjusting the seat height on the shock absorber	41	14.5	Adding front brake fluid	68
12.3	Adjusting the seat height on the fork	42	14.6	Checking that the brake linings of the front brake are secured	69
12.4	Adjusting the seat height on the frame	43	14.7	Changing the brake linings of the front brake	70
13	SERVICE WORK ON THE CHASSIS	46	14.8	Checking the free travel of the rear brake lever	72
13.1	Raising the motorcycle with a lift stand	46	14.9	Adjusting the free travel of the foot brake lever (SX-E 5)	73
13.2	Removing the motorcycle from the lift stand	46	14.10	Adjusting the basic position of the rear brake lever	73
13.3	Bleeding the fork legs	46	14.11	Checking the rear brake fluid level	74
13.4	Cleaning the dust boots of the fork legs	47	14.12	Adding rear brake fluid	75
13.5	Removing the fork protector	48	14.13	Checking the brake linings and the brake lining retainers of the rear brake	77
13.6	Installing the fork protector	48	14.14	Changing the rear brake linings	77
13.7	Removing the fork legs	48	15	WHEELS, TIRES	82
13.8	Installing the fork legs	49	15.1	Removing the front wheel	82
13.9	Removing the lower triple clamp	50	15.2	Installing the front wheel	82
13.10	Installing the lower triple clamp	51	15.3	Removing the rear wheel	83
13.11	Checking the steering head bearing play	53	15.4	Installing the rear wheel	84
13.12	Adjusting the steering head bearing play	54	15.5	Checking the tire condition	85
13.13	Lubricating the steering head bearing	55	15.6	Checking tire pressure	86
13.14	Removing the start number plate	55	15.7	Checking the spoke tension	86
13.15	Installing the start number plate	55	16	LV TRACTION BATTERY, BATTERY CHARGER	88
13.16	Removing front fender	56	16.1	Overview of battery charger	88
13.17	Installing front fender	56	16.2	Positioning the battery charger	88
13.18	Removing the shock absorber	57	16.3	Charging the LV traction battery	89
13.19	Installing the shock absorber	57	17	COOLING	93
13.20	Checking the rubber buffer and pivot points of the shock absorber (SX-E 3)	58	17.1	Cooling	93
13.21	Removing the seat	58	18	CLEANING, CARE	94
13.22	Mounting the seat	59	18.1	Cleaning the motorcycle	94
13.23	Checking the chain for dirt	59	19	STORAGE	96
13.24	Cleaning the chain	59	19.1	Storage	96
13.25	Checking the chain tension	60	19.2	Preparing for use after storage	96
13.26	Adjusting the chain tension	61	20	TROUBLESHOOTING	97
13.27	Checking the chain, rear sprocket, motor sprocket, and chain guide	61	21	TECHNICAL SPECIFICATIONS	99
13.28	Adjusting the chain guide	64	21.1	Engine	99
13.29	Checking the frame	64	21.2	Chassis	100
13.30	Checking the link fork	64	21.3	Electrical system	101
13.31	Checking the rubber grip	64	21.4	Tires	101
14	BRAKE SYSTEM	66	21.5	Fork	101
14.1	Checking the play of the front brake lever	66	21.5.1	SX-E 3	101

TABLE OF CONTENTS

21.5.2	SX-E 5.....	101
21.6	Shock absorber.....	102
21.6.1	SX-E 3.....	102
21.6.2	SX-E 5.....	102
21.7	Chassis tightening torques	103
22	SUBSTANCES	105
23	AUXILIARY SUBSTANCES	106
24	STANDARDS	107
25	INDEX OF SPECIAL TERMS.....	108
26	LIST OF ABBREVIATIONS.....	109
27	LIST OF SYMBOLS.....	110
27.1	Yellow and orange symbols.....	110
INDEX	112

1.1 Symbols used

The meaning of specific symbols is described below.

	Indicates an expected reaction (e.g., of a work step or a function).
	Indicates an unexpected reaction (e.g., of a work step or a function).
	Indicates work that requires expert knowledge and technical understanding. In the interest of the safety of your child, have these jobs performed in an authorized KTM workshop. Your motorcycle will be cared for there to the highest degree by specially trained experts using the special tools required.
	Indicates a page reference (more information is provided on the specified page).
	Indicates information with more details or tips.
	Indicates the result of a testing step.
	Indicates the end of an activity, including potential reworking.
	Indicates a voltage measurement.
	Indicates a current measurement.

1.2 Formats used

The typographical formats used in this document are explained below.

Proprietary name	Indicates a proprietary name.
Name®	Indicates a protected name.
Brand™	Indicates a brand available on the open market.
<u>Underlined terms</u>	Refer to technical details of the vehicle or indicate technical terms, which are explained in the glossary.

2.1 Use definition – intended use

This vehicle is designed and constructed to withstand the stresses and strains of regular racing if the maximum rider weight is not exceeded.



Info

Only operate this vehicle in closed-off areas remote from public road traffic.
Only use the lithium-ion battery while it is inside the vehicle.

2.2 Misuse

The vehicle must only be used as intended.

Dangers can arise for people, property and the environment through use not as intended.

Any use of the vehicle beyond the intended and defined use constitutes misuse.

Misuse also includes the use of operating and auxiliary fluids which do not meet the required specification for the respective use.

2.3 Notes/warnings

Pay close attention to the notes/warnings.



Info

Various information and warning labels are affixed to the vehicle. Do not remove information/warning labels. If they are missing, you or others may not recognize dangers and may therefore be injured.

2.4 Grades of risks



Warning

Identifies a danger that is likely to lead to fatal or serious injury if the appropriate measures are not taken.



Caution

Identifies a danger that may lead to minor injuries if the appropriate measures are not taken.

Note

Identifies a danger that will lead to considerable machine and material damage if the appropriate measures are not taken.



Warning

Identifies a danger that will lead to environmental damage if the appropriate measures are not taken.

2.5 Tampering warning

No mechanical, electrical or electronic modifications may be made to the vehicle, since safe operation cannot be guaranteed otherwise.

Examples of inadmissible manipulation and modifications:

- 1 Opening the rechargeable lithium-ion battery (LV traction battery) or the engine.
- 2 Using the vehicle or the rechargeable lithium-ion battery when proper maintenance has not been performed.
- 3 Using the vehicle or the rechargeable lithium-ion battery outside of its defined use.
- 4 Using a damaged lithium-ion battery.

2.6 Safe operation



Warning

Danger of accidents A lack of physical and mental readiness on the part of the child poses a major risk.

Children often underestimate or fail to recognize dangerous situations.

- Your child must already be able to ride a bicycle.
- Your child must be able to put the vehicle upright independently after a fall.
- Your child must understand that rules and instructions given by you or another guardian must be followed.
- Make it clear to your child that they should not, under any circumstances, operate the vehicle without the supervision of an adult.
- Make sure that the riding mode is appropriate for your child's riding ability and for the riding conditions.
- Do not ask too much of your child.
Observe their stamina, their riding technique and how motivated they are. Have your child complete a training course.
- Only allow your child to drive the vehicle if your child is both physically and mentally ready and can reach all controls safely.



Warning

Danger of burns Some vehicle components become hot when the vehicle is operated.

- Do not touch any parts such as the engine, lithium-ion battery, damper, or brake system before these vehicle parts have cooled down.
- Let the vehicle parts cool down before you perform any work on the vehicle.

This vehicle is a low-voltage electric motorcycle. For this reason, follow the safety and care instructions that apply when using an electric motor.

If the throttle grip is closed and no **recuperation** (📖 p. 26) is activated, the vehicle continues to roll without much delay. The vehicle speed decreases on account of rolling resistance and air resistance.

Because this vehicle does not have a manual transmission, there is no clutch.

As with a conventional drive with a combustion engine, the operating temperature rises according to use and depending on the ambient temperature and the cleanliness of the cooling surfaces. If the temperature of the motor, the lithium-ion battery, or the electronics rises above the permissible operating temperature, the power of the vehicle will be reduced considerably. This protects the system against damage from overheating. When power reduction is imminent, the active driving mode indicator flashes. When power reduction is active, all three driving mode indicators light up. When all components have returned to their normal operating temperature, full system power is restored after restarting.

Only operate the vehicle when it is in perfect technical condition, in accordance with its intended use, and in a safe and environmentally compatible manner.

Have malfunctions that impair safety promptly eliminated by an authorized KTM workshop.

Adhere to the information and warning labels on the vehicle.

2.7 Fall or accident

If the vehicle is lying on its side, it switches from ready mode to standby mode after five seconds. To return the vehicle to ready mode, place the vehicle in the upright position and close the throttle grip beyond the basic position.

After a fall or accident, check the vehicle as usual when preparing for use.

2.8 Protective clothing



Warning

Risk of injury Missing or poor protective clothing presents an increased safety risk.

- Ensure your child wears appropriate protective clothing such as helmet, boots, gloves as well as trousers and a jacket with protectors on all rides.
- Always use protective clothing for your child that is in good condition and meets the legal requirements.
- When you ride a motorcycle, set an example for your child and wear suitable protective clothing.

2.9 Work on vehicle, engine, and rechargeable lithium-ion battery



Warning

Risk of injury There is a risk of electric shock when working on live components.

Work on live components requires special training, qualifications, and tools.

- Have all work that is not described and explained performed by trained KTM mechanics only.
- Do not open the electric engine or the lithium-ion battery (LV traction battery).



Warning

Risk of injury The vehicle runs quietly, even when it is ready to operate.

The vehicle starts moving in an uncontrolled manner if the throttle grip is accidentally touched while work is being performed on the vehicle.

- Ensure that the vehicle is switched off with the On/Off button and remains switched off before starting any work on the vehicle.
- Remove the LV traction battery from the vehicle and the magnetic switch from the holder before starting any work on the vehicle.
- Secure the vehicle against access by unauthorized persons while you are performing work on the vehicle.

2.10 Environment

When you respect the rights of others and use your motorcycle legally, you will help protect the future of motorcycle sport and avoid most conflicts and problems.

When disposing of used oil, other operating and auxiliary fluids, and used components, comply with the applicable laws and regulations in your country.

When disposing of the lithium-ion battery (LV traction battery), observe the relevant laws and guidelines of your country.

Your authorized KTM dealer can dispose of the LV traction battery free of charge and in an environmentally compatible manner.

Because motorcycles are not subject to the EU regulations governing the disposal of used vehicles, there are no legal regulations that pertain to the disposal of an end-of-life motorcycle. Your authorized KTM dealer will be glad to assist you.

Electrical devices like the battery charger may not be disposed of with household waste. Electrical devices must be disposed of through the appropriate recycling centers. Contact your municipality or your authorized KTM dealer.

2.11 Owner's Manual

It is important that you read this Owner's Manual carefully and completely before your child makes his or her first trip. The Owner's Manual contains useful information and many tips for you and your child on how to operate, handle, and service your motorcycle. This is the only way for you to find out how to ideally tune the vehicle and how to protect your child from injury.



Tip

Store the Owner's Manual on your terminal device, for example, so that you can read it whenever you need to.

If you would like to know more about the vehicle or have questions on the material you read, please contact an authorized KTM dealer.

The Owner's Manual is an important component of the vehicle. If the vehicle is sold, the Owner's Manual must be downloaded again by the new owner.

The Owner's Manual can be downloaded several times using the QR code or the link on the delivery certificate.

The Owner's Manual is also available for download from your authorized KTM dealer and on the KTM website. A printed copy can also be ordered from your authorized KTM dealer.

International KTM Website: KTM.COM

2.12 Fire hazard



Warning

Fire hazard Damaged rechargeable lithium-ion batteries present a fire hazard.

Massive mechanical damage may cause an internal cell short circuit and then cause the battery to self-ignite.

- Contact KTM customer service immediately if major damage to the rechargeable lithium-ion battery has occurred.

There is no particular fire hazard for this vehicle when the rechargeable lithium-ion battery (LV traction battery) is intact.

However, should the vehicle catch fire, inform the fire department responsible that an electric vehicle with a rechargeable lithium-ion battery is on fire.

3 IMPORTANT NOTES

3.1 Manufacturer warranty, implied warranty

The work prescribed in the service schedule must only be carried out in an authorized KTM workshop and confirmed in the **KTM Dealer.net**, as otherwise all warranty claims will be void. Damage or secondary damage caused by tampering with and/or conversions on the vehicle are not covered by the manufacturer warranty.

3.2 Fuel, auxiliary substances

Use the operating and auxiliary substances (such as oils and lubricants) specified in the Owner's Manual.

3.3 Spare parts, accessories

For the safety of your child, only use spare parts and accessory products that are approved and/or recommended by KTM and have them installed by an authorized KTM workshop. KTM accepts no liability for other products and any resulting damage or loss.

Certain spare parts and accessory products are specified in parentheses in the descriptions. Your authorized KTM dealer will be glad to advise you.

The current **KTM PowerParts** for your vehicle can be found on the KTM website.
International KTM Website: KTM.COM

3.4 Service

A prerequisite for perfect operation and prevention of premature wear is that the service, care, and tuning work is properly carried out as described in the Owner's Manual. An incorrect suspension setting can lead to damage and breakage of chassis components.

Use of the vehicle under difficult conditions, such as on sand or on wet and muddy surfaces, can result in significantly increased wear of components, such as the drive train, brake system, or suspension components. For this reason, it may be necessary to inspect or replace parts before the next scheduled service.

It is imperative that you adhere to the stipulated service intervals. If you observe these exactly, you will ensure a much longer service life for your motorcycle.

The relevant mileage or time interval is whichever occurs first.

3.5 Figures

The figures contained in the manual may depict special equipment.

In the interest of clarity, some components may be shown disassembled or may not be shown at all. It is not always necessary to disassemble the component to perform the activity in question. Please follow the instructions in the text.

3.6 Customer service

Your authorized KTM dealer will be happy to answer any questions you may have on your vehicle and KTM.

A list of authorized KTM dealers can be found on the KTM website.
International KTM Website: KTM.COM

3.7 Power supply



M02015-10

A rechargeable lithium-ion battery **1** (LV traction battery) is installed in the vehicle. The LV traction battery supplies the electric motor **2** and multifunctional element **3** with voltage. The LV traction battery is firmly bolted to the frame and engine.

3.8 Operation at low temperatures

In order to protect the LV traction battery, the engine control reduces the power at low component temperatures. If the temperature of the LV traction battery is too low, the active ride mode indicator flashes. The vehicle can continue to be operated. The LV traction battery is not damaged by the reduction in power. The LV traction battery warms up during vehicle operation. If the temperature of the LV traction battery exceeds a threshold value, full vehicle power is restored after the vehicle is restarted.

4 VIEW OF VEHICLE

4.1 View of vehicle, front left (example)



M02018-10

- ❶ Front brake lever (📖 p. 16)
- ❷ Magnetic switch on handlebar (📖 p. 16)
- ❸ Magnetic switch under the seat (📖 p. 17)
- ❹ Plug-in stand holder
- ❺ Charging socket

4.2 View of vehicle, rear right (example)

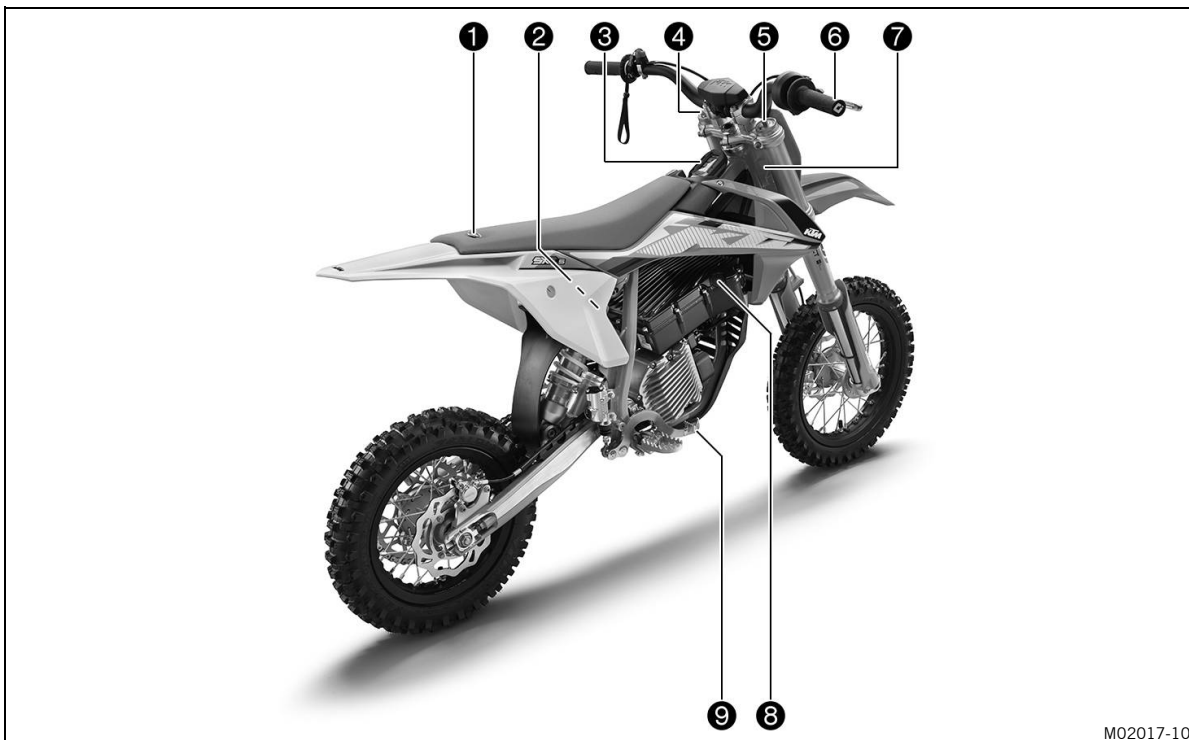

M02017-10

- ① Quick release of seat
- ② Shock absorber rebound adjuster
- ③ Multifunctional element (📖 p. 19)
- ④ Fork air pressure adjuster
- ⑤ Fork rebound adjustment
- ⑥ Throttle grip (📖 p. 16)
- ⑦ Vehicle identification number (📖 p. 14)
- ⑧ On/Off button (📖 p. 16)
- ⑨ Foot brake lever (📖 p. 18) **(SX-E 5)**

5 SERIAL NUMBERS

5.1 Vehicle identification number

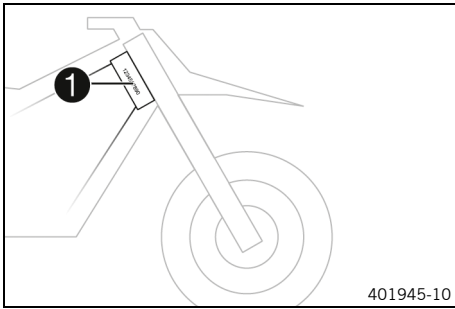

The vehicle identification number ❶ is stamped on the right side of the steering head.

5.2 Frame label

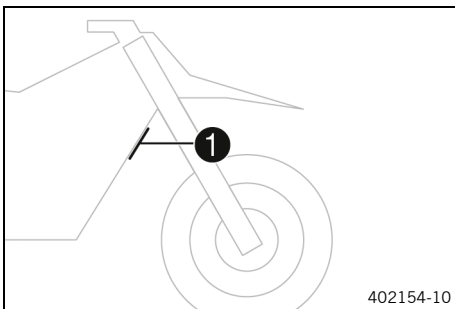

Frame label ❶ is located on the front frame tube.

5.3 Engine number

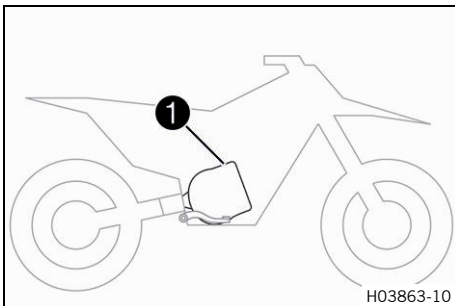

The engine number ❶ is located on the right side of the motor below the LV traction battery.

5.4 Fork article number

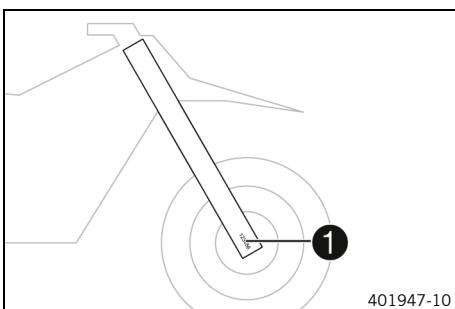

The fork article number ❶ is stamped on the outside of the axle clamp.

5.5 Shock absorber article number

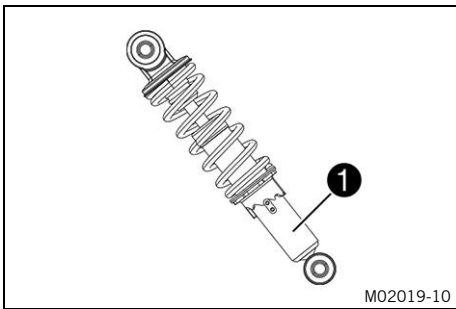

(SX-E 3)

Shock absorber article number **1** is stamped on the bottom of the shock absorber.

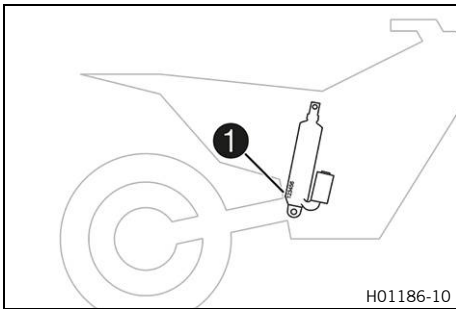

(SX-E 5)

The shock absorber article number **1** is stamped on the bottom of the shock absorber toward the right-hand side.

5.6 Battery identification number

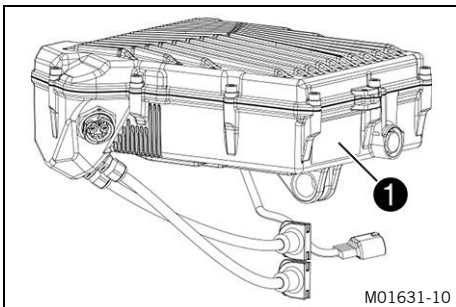

The battery identification number (**BIN**) **1** is located on a sticker on the LV traction battery.

6.1 Front brake lever

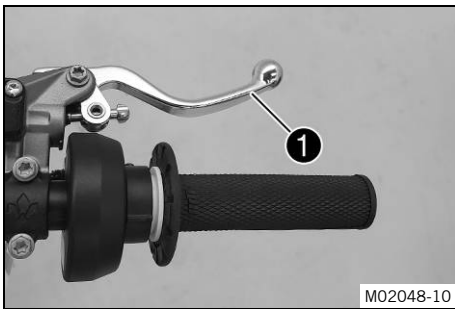

Front brake lever **1** is fitted on the right side of the handlebar. The front brake is engaged using the front brake lever.

6.2 Throttle grip

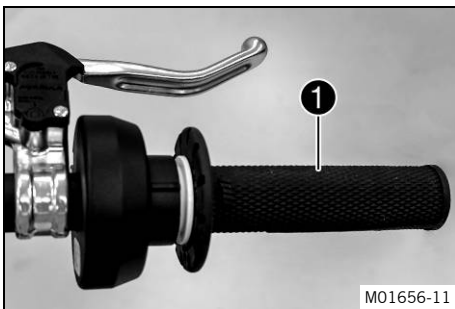

The throttle grip **1** is fitted on the right side of the handlebar. After activation, the vehicle initially does not react to the throttle grip to prevent accidental acceleration. The throttle grip must be closed beyond the basic position to activate the throttle response. Only then does the vehicle switch to ready mode.

6.3 On/Off button



The On/Off button **1** is located on the right side of the LV traction battery.

Possible states

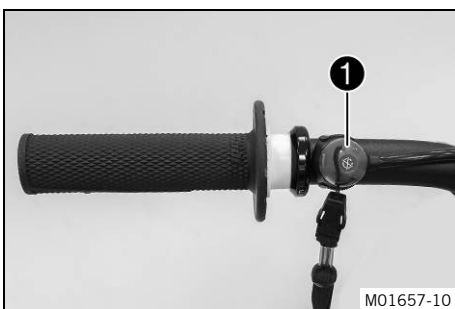

- Vehicle switched off – In this operating state, the vehicle is deactivated.
- Vehicle in standby mode – In this operating state, the vehicle is activated.

6.4 Magnetic switch on handlebar



The holder for the red magnetic switch **1** is located on the left side of the handlebar.

Possible states

- Magnetic switch  mounted on handlebar – When the magnetic switch is mounted on the handlebar, the vehicle can be activated and ridden.
- Magnetic switch  removed from handlebar – When the magnetic switch is removed from the handlebar, the vehicle cannot be activated or ridden.



Warning

Risk of injury If the magnetic switch remains in the holder during a fall, the vehicle is not immediately deactivated.

- Make sure that the loop of the magnetic switch is securely attached to the user’s protective clothing or wrist so that the magnetic switch is disconnected from the holder in the event of a fall.

If the red magnetic switch on the handlebar is disconnected from the holder, e.g., in the event of a fall, the vehicle is deactivated. By removing the red magnetic switch from the handlebar, the vehicle can be quickly deactivated in any operating state.

The red magnetic switch on the handlebar cannot be replaced with the gray magnetic switch under the seat (🔒 (📖 p. 17)).

6.5 Magnetic switch under the seat





The holder for the gray magnetic switch **1** is located under the seat.

By removing the gray magnetic switch under the seat, you can prevent the riding mode from being changed.

Locking the ride mode is recommended if you have not yet gained sufficient experience for higher ride modes with more power and torque.

Possible states

- Magnetic switch  mounted under the seat – When the magnetic switch is mounted under the seat, the ride mode can be changed.
- Magnetic switch  removed – When the magnetic switch under the seat is removed, the ride mode cannot be changed.

The gray magnetic switch under the seat cannot be replaced with the red magnetic switch on the handlebar (🔒 (📖 p. 16)).

6.6 Rear brake lever (SX-E 3)

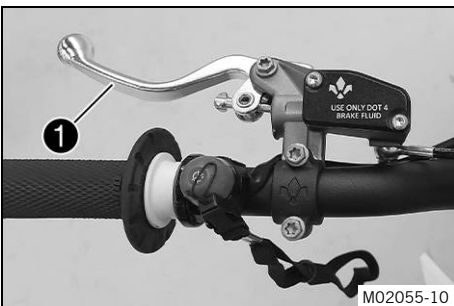

The rear brake lever **1** is fitted on the left side of the handlebar. The rear brake is engaged with the rear brake lever.

6.7 Foot brake lever (SX-E 5)

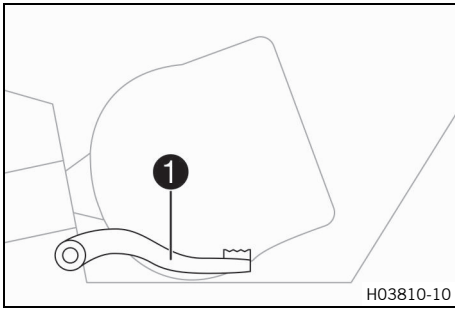

Foot brake lever ❶ is located in front of the right footrest. The rear brake is engaged with the foot brake lever.

6.8 Plug-in stand

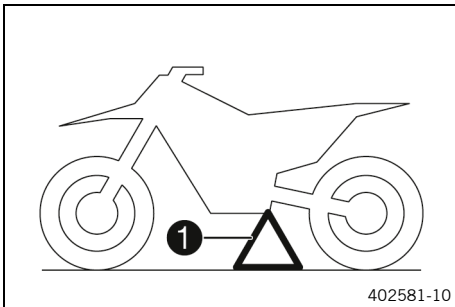

The fixture for plug-in stand ❶ is located on the frame on the left side of the vehicle. The plug-in stand is used to park the motorcycle.



Info

Remove the plug-in stand before riding.

6.9 Diagnostics connector

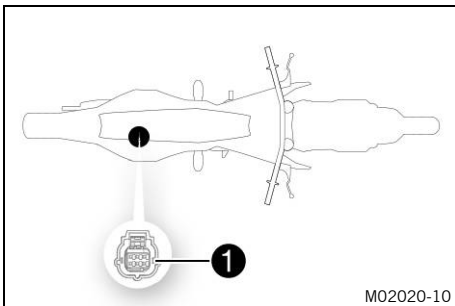

Diagnostics connector ❶ is located under the seat.

7.1 Multifunctional element

The multifunctional element is mounted in front of the seat.

Overview of multifunctional element

- ❶ Ride mode button (📖 p. 19)
- ❷ Ride mode display (📖 p. 20)
- ❸ Malfunction indicator lamp (📖 p. 20)
- ❹ Charging level indicator (📖 p. 20)

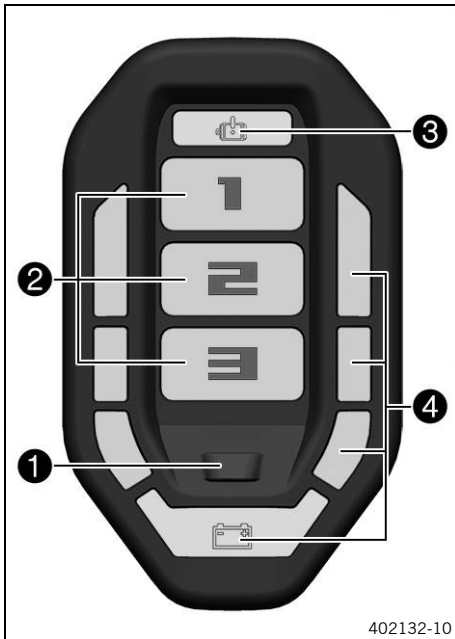

7.2 Ride mode button

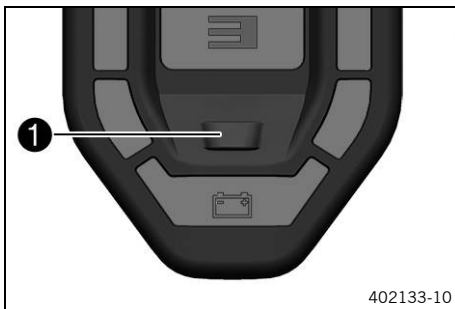

The ride mode button ❶ determines the ride mode (📖 p. 20). The ride mode button is only active if the magnetic switch under the seat (📖 p. 17) is mounted.

Possible states

- The vehicle is in standby mode – The ride mode button is active.
- The vehicle is in ready mode – The ride mode button is active.
- All other vehicle conditions – The ride mode button is not active.

7.3 Ride mode display

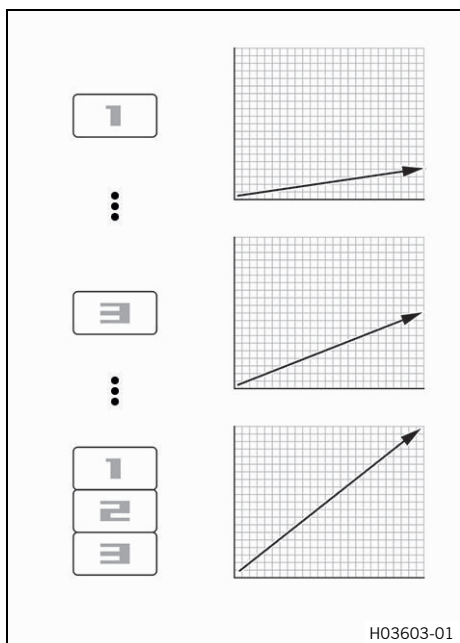

Red ride mode displays with the numbers **1**, **2**, or **3** show the ride mode selected.

Six ride modes are available. The ride modes define how the vehicle will respond to operation of the throttle grip.

The lowest torque is available in ride mode **1**. The maximum speed of the vehicle is limited. This ride mode is suitable for familiarization.

In ride modes **5** and **6**, the full torque is available. The maximum speed of the vehicle can be utilized. These ride modes should only be selected once sufficient riding experience has been gained and the vehicle can be handled safely.

The ride modes between **1** and **5** represent intermediate stages in terms of torque and maximum speed.

In ride modes **3** and **6**, an additional recuperation function (p. 26) is available.

Ride modes **1** to **3** are indicated by the illuminated single digit.

When ride modes **4**, **5**, and **6** are activated, the activated ride mode is displayed as the sum of the illuminated digits.

i Info

When the magnetic switch under the seat (p. 17) is not mounted, the ride mode cannot be changed.

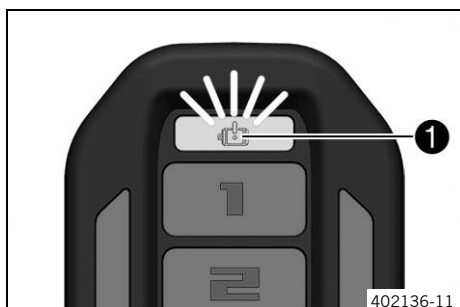

The ride modes are switched through in ascending order; after ride mode **6**, the ride mode jumps back to **1**.

7.4 Malfunction indicator lamp



The warning tones emitted by the multifunctional element are synchronized with the flashing rhythm of malfunction indicator lamp **1**.

Possible states

	The malfunction indicator lamp flashes – There is a malfunction in the vehicle electronic system.
	The malfunction indicator lamp lights up – The system is carrying out a self-check or has been disabled during driving.

7.5 Charging level indicator

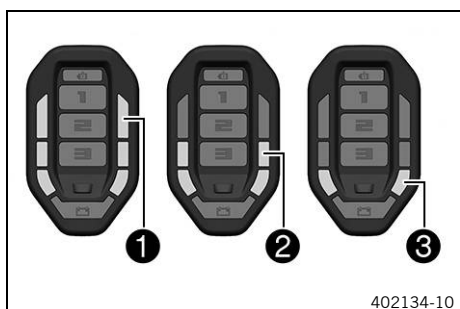

All segments **1** light up: charging level 70% - 100%.

Four segments **2** light up: charging level 50% - 70%.

Two segments **3** light up: charging level 30% - 50%.

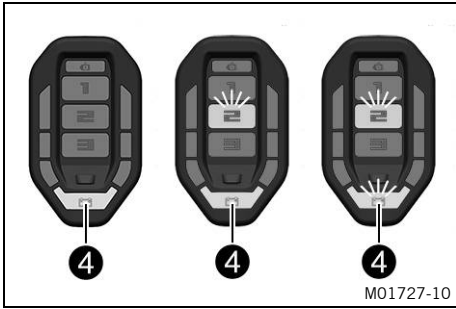

The last segment ④ lights up in yellow: charging level 20% - 30%.

The last segment ④ lights up in red and the driving mode indicator flashes red: charging level 10%–20%.

The last segment ④ and the driving mode indicator light up in red: charging level 0%–10%.

7.6 Power reduction

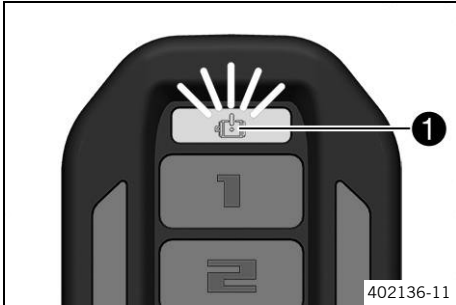

If the charging level (📖 p. 20) of the LV traction battery is too low or the system temperature is outside of the permissible range, the power is automatically reduced.

The selected ride mode and the malfunction indicator lamp flash when the power has been reduced.

i Info

The blink code of malfunction indicator lamp ① can be used to determine the reason for the power reduction (see Troubleshooting chapter).

8.1 Advice on preparing for first use



Warning

Danger of accidents A lack of physical and mental readiness on the part of the child poses a major risk.

Children often underestimate or fail to recognize dangerous situations.

- Your child must already be able to ride a bicycle.
- Your child must be able to put the vehicle upright independently after a fall.
- Your child must understand that rules and instructions given by you or another guardian must be followed.
- Make it clear to your child that they should not, under any circumstances, operate the vehicle without the supervision of an adult.
- Make sure that the riding mode is appropriate for your child's riding ability and for the riding conditions.
- Do not ask too much of your child.
Observe their stamina, their riding technique and how motivated they are. Have your child complete a training course.
- Only allow your child to drive the vehicle if your child is both physically and mentally ready and can reach all controls safely.



Warning

Risk of injury Missing or poor protective clothing presents an increased safety risk.

- Ensure your child wears appropriate protective clothing such as helmet, boots, gloves as well as trousers and a jacket with protectors on all rides.
- Always use protective clothing for your child that is in good condition and meets the legal requirements.
- When you ride a motorcycle, set an example for your child and wear suitable protective clothing.



Warning

Danger of crashing Different tire tread patterns on the front and rear wheel impair the handling characteristic.

Different tire tread patterns can make the vehicle significantly more difficult to control.

- Make sure that only tires with a similar tire tread pattern are fitted to the front and rear wheel.



Warning

Danger of accidents The vehicle is not designed to carry passengers.

- Make it clear to your child that he or she must not carry a passenger.



Warning

Danger of accidents The brake system fails in the event of overheating.

If the foot brake lever is not released, the brake linings drag continuously.

- Ensure that your child raises his or her foot from the foot brake lever if he or she does not want to brake.



Warning

Danger of accidents The suspension components will become damaged or destroyed if overloaded.

- Do not exceed the maximum permissible weight of the rider.



Warning

Risk of misappropriation People who act without authorization endanger themselves and others.

- Never leave the vehicle unattended.
- Protect the vehicle against access by unauthorized persons.

- Ensure that the pre-sales inspection work has been carried out by an authorized KTM workshop.
- ✓ The delivery certificate is transferred upon vehicle handover.
- Read through the entire Owner's Manual together with your child before riding for the first time.



Info

Pay special attention to the safety instructions and to the risk of injury. Explain to your child the techniques of riding and falling, e.g., how shifting weight can influence handling characteristics.

- Familiarize your child with the controls.
- Adjust the basic position of the front brake lever. (📖 p. 66)
- Adjust the basic position of the rear brake lever. 🏍️ (📖 p. 73)
- Before using the vehicle for the first time, ensure that the basic settings of the chassis are suitable for the weight of your child.
- Allow your child to become accustomed to the handling of the motorcycle on suitable terrain, preferably on a large, open field.



Info

To give your child a feeling for the brake system, start by pushing your child. Do not start the motor until your child is able to apply the necessary front brake pressure. Your child should begin by riding to another person, who can help your child stop and turn.

- Erect obstacles for your child to navigate around so that your child becomes accustomed to handling the vehicle.
- Your child should also try to ride as slowly as possible and in a standing position to get a better feeling for the motorcycle.
- Do not let your child ride on terrain that exceeds your child's capabilities and experience.
- Your child should hold the handlebar firmly with both hands and keep his or her feet on the footrests when riding.
- Make sure the maximum permissible weight of the rider is not exceeded.

Guideline

Maximum rider weight	45 kg (99 lb.)
Maximum rider size	< 130 cm (< 51.2 in)

- Check the spoke tension. (📖 p. 86)

Guideline

The spoke tension must be checked after half an hour of operation.
--



9.1 Checks and maintenance measures when preparing for use

i Info

Before every trip, check the condition of the vehicle and ensure that it is safe to operate. The vehicle must be in perfect technical condition when it is being operated.

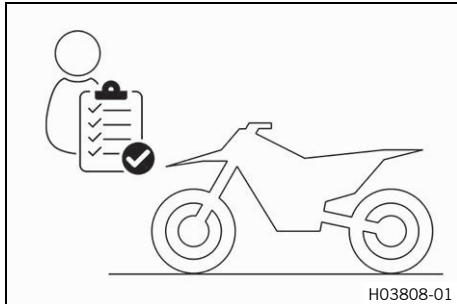

- Check the throttle grip, both magnetic switches, LV traction battery, multifunctional element, and electric engine for external damage.
- Check the front brake fluid level. (📖 p. 67)
- Check the rear brake fluid level. (📖 p. 74)
- Check that the brake linings of the front brake are secured. (📖 p. 69)
- Check that the brake linings of the rear brake are secured. (📖 p. 77)
- Check that the brake system is functioning properly.
- Check the chain for dirt. (📖 p. 59)
- Check the chain, rear sprocket, motor sprocket, and chain guide. (📖 p. 61)
- Check the chain tension. (📖 p. 60)
- Check the tire condition. (📖 p. 85)
- Check tire pressure. (📖 p. 86)
- Check the spoke tension. (📖 p. 86)

i Info

The spoke tension must be checked regularly as incorrect spoke tension will strongly impair riding safety.

- Clean the dust boots of the fork legs. (📖 p. 47)
- Bleed the fork legs. (📖 p. 46)
- Check the settings of all controls and ensure that they can be operated smoothly.
- Check the tightness of the safety-relevant screws and nuts which are easily accessible.
- Check the charging level of the LV traction battery.

9.2 Starting the vehicle

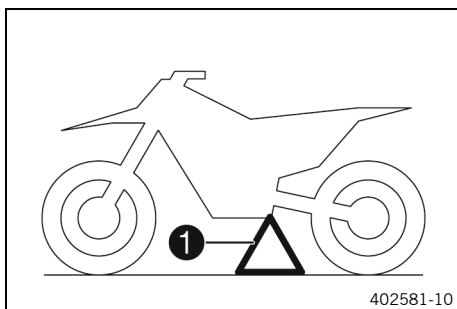

- Remove plug-in stand ❶.
 - Mount the magnetic switch ☒ on the holder on the handlebar.
- Guideline
- To prevent unwanted activation, only mount the magnetic switch immediately before going on a ride.
- Press and hold the On/Off button until the multifunctional element lights up.
 - ✓ The vehicle is in standby mode.

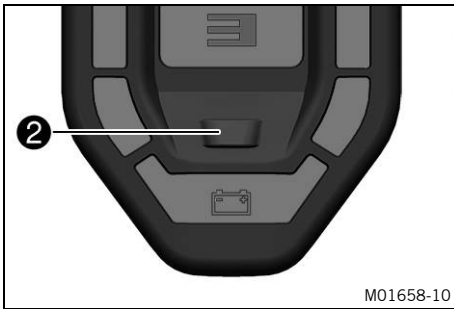

Optional:

- Press ride mode button **2** to change the ride mode.

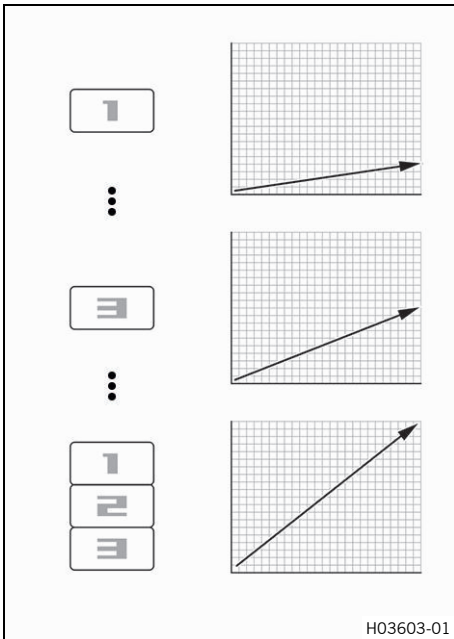

- Select one of the ride modes (📖 p. 20).
- Close the throttle grip beyond the basic position.
 - ✓ The vehicle emits a beep, is ready to ride, and reacts to the throttle grip.

9.3 Starting off

Info
The plug-in stand must be removed before riding.

- Open the throttle carefully.

9.4 Braking

Warning
Danger of accidents Excessively forceful application of the brakes blocks the wheels.

- Explain to your child that he or she must adapt the braking to the traffic situation and the road conditions.

Warning
Danger of accidents A spongy pressure point on the front or rear brake reduces braking efficiency.

- Check the brake system and do not allow your child to continue riding until the problem is eliminated. (Your authorized KTM workshop will be glad to help.)



Warning

Danger of accidents Moisture and dirt impair the brake system.

- Explain to your child that he or she must brake carefully several times to dry out and remove dirt from the brake linings and the brake discs.

- On sandy, wet, or slippery surfaces, use mostly the rear brake if possible.
- Try to complete the braking procedure before riding into a curve.

9.5 Recuperation (SX-E 5)

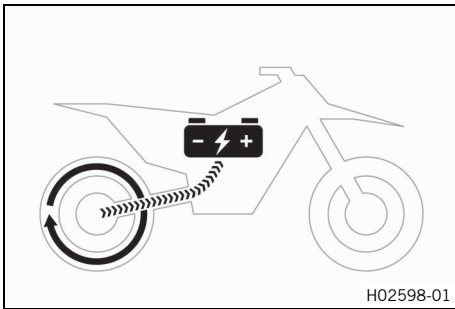

The LV traction battery is charged by the electric engine in ride mode **3** and **6** (📖 p. 20) when the throttle grip is closed beyond the basic position in overrun.

The recuperation function results in an increased engine braking effect.

The recuperation effect is stronger in ride mode **6** than in ride mode **3**.



Info

The recuperation function is not available in the remaining ride modes.

9.6 Stop, park



Warning

Risk of misappropriation People who act without authorization endanger themselves and others.

- Never leave the vehicle unattended.
- Protect the vehicle against access by unauthorized persons.



Warning

Danger of burns Some vehicle components become hot when the vehicle is operated.

- Do not touch any parts such as the engine, lithium-ion battery, damper, or brake system before these vehicle parts have cooled down.
- Let the vehicle parts cool down before you perform any work on the vehicle.

Note

Material damage The vehicle may be damaged by incorrect procedure when parking.

Significant damage may be caused if the vehicle rolls away or falls over.

The components for parking the vehicle are designed only for the weight of the vehicle.

- Park the vehicle on a firm and level surface.
- Ensure that nobody sits on the vehicle when the vehicle is parked on a stand.

- Apply the brakes on the motorcycle.
- Press and hold the On/Off button until the multifunctional element goes out.
- Remove the magnetic switch ☒ from the holder on the handlebar.
- Park the motorcycle on firm ground.

9.7 Transporting

Note

Danger of damage The parked vehicle can roll away or fall over.

- Park the vehicle on a firm and level surface.

Note

Fire hazard Hot vehicle components pose a fire hazard and explosion risk.

- Do not park the vehicle near to materials which are highly flammable or explosive.
- Allow the vehicle to cool down before covering it.

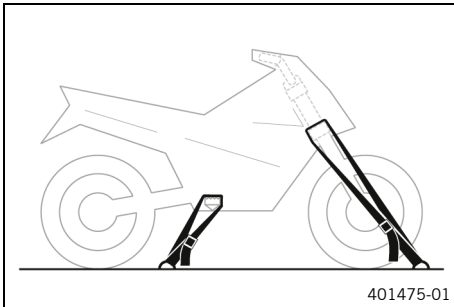

- Press and hold the On/Off button until the multifunctional element goes out.
- Remove the magnetic switch ☒ from the holder on the handlebar.
- Use tension belts or other suitable devices to secure the motorcycle against falling over or rolling away.

10 SERVICE SCHEDULE

10.1 Additional information

Any further work that results from the service work must be ordered separately and invoiced separately. Different service intervals may apply in your country, depending on the local operating conditions. Individual service intervals and scopes may change in the course of technical developments. The most up-to-date service schedule can always be found on KTM Dealer.net. Your authorized KTM dealer will be happy to advise you.

Always bring the battery charger with you when having the vehicle serviced.

The use of a service hour counter is recommended in order to be able to check the mileage at any time.

Service hour counter (45412920000)

10.2 Service schedule

	every 12 months				
	Every 80 operating hours				
	Every 40 operating hours				
	Every 20 operating hours				
	After 10 operating hours				
Check the battery charger plug for damage and dirt. 🛠️	○	●	●	●	●
Read out the fault memory using the KTM diagnostics tool. 🛠️	○	●	●	●	●
Check that the electrical system is functioning properly. 🛠️	○	●	●	●	●
Check and charge the LV traction battery. 🛠️	○	●	●	●	●
Check that the brake linings of the front brake are secured. (📖 p. 69)	○	●	●	●	●
Check that the brake linings of the rear brake are secured. (📖 p. 77)	○	●	●	●	●
Check the brake discs. (📖 p. 66)	○	●	●	●	●
Check the brake lines for damage and tightness.	○	●	●	●	●
Check the front brake fluid level. (📖 p. 67)	○	●	●	●	●
Change the front brake fluid. 🛠️					●
Check the rear brake fluid level. (📖 p. 74)	○	●	●	●	●
Change the rear brake fluid. 🛠️					●
Replace the sealing cup of the brake cylinder of the rear brake system. (SX-E 5) 🛠️		●	●	●	●
Check the play of the front brake lever. (📖 p. 66)	○	●	●	●	●
Check the free travel of the rear brake lever. (📖 p. 72)	○	●	●	●	●
Check cables and wires for damage and ensure they are routed without kinks. 🛠️	○	●	●	●	●
Check the frame. 🛠️ (📖 p. 64)		●	●	●	●
Check the link fork. 🛠️ (📖 p. 64)		●	●	●	●
Check the fork bearing for play. 🛠️		●	●	●	●
Check the heim joint for play. 🛠️		●	●	●	●
Check the tire condition. (📖 p. 85)	○	●	●	●	●
Check tire pressure. (📖 p. 86)	○	●	●	●	●
Check the wheel bearing for play. 🛠️		●	●	●	●
Check the wheel hubs. 🛠️		●	●	●	●
Check the rim run-out. 🛠️	○	●	●	●	●
Check the spoke tension. (📖 p. 86)	○	●	●	●	●
Check the chain, rear sprocket, motor sprocket, and chain guide. (📖 p. 61)	○	●	●	●	●
Check the chain tension. (📖 p. 60)	○	●	●	●	●
Grease all moving parts (e.g., hand lever, chain, etc.) and check for smooth operation. 🛠️	○	●	●	●	●
Service the fork. (SX-E 3) 🛠️			●	●	●

	every 12 months				
	Every 80 operating hours				
	Every 40 operating hours				
	Every 20 operating hours				
	After 10 operating hours				
Service the fork. (SX-E 5) 🛠️			•	•	
Check the rubber buffer and pivot points of the shock absorber. (SX-E 3) (📖 p. 58)		•	•	•	
Perform the shock absorber service. (SX-E 5) 🛠️				•	
Check the tightness of the safety-relevant screws and nuts which are easily accessible. 🛠️	○	•	•	•	•
Check the steering head bearing play. (📖 p. 53)	○	•	•	•	
Lubricate the steering head bearing. 🛠️ (📖 p. 55)					•
Check the pinion shaft bearings, O-rings and the bearing seals. 🛠️		•			
Change the pinion shaft bearings, the O-rings and the bearing seals. 🛠️			•	•	
Final check: Check the vehicle for operating safety and take for a test ride. 🛠️	○	•	•	•	•
Read out the fault memory after the test ride using the KTM diagnostics tool. 🛠️	○	•	•	•	•
Make a service entry in KTM Dealer.net . 🛠️	○	•	•	•	•

- One-time interval
- Periodic interval

11.1 Checking the basic chassis setting with the rider's weight

i Info

When adjusting the basic chassis setting, first adjust the shock absorber and then the fork.

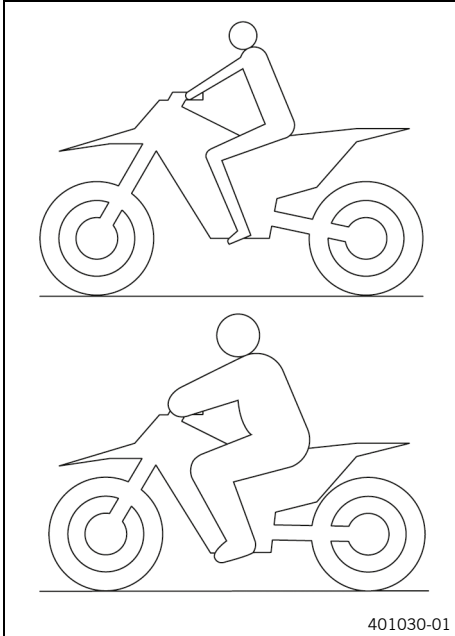

- For optimal motorcycle riding characteristics and to avoid damage to forks, shock absorbers, link fork and frame, the basic settings of the suspension components must match the rider's weight.
- This vehicle is delivered pre-set for a standard rider's weight (with full protective clothing).

Guideline

Standard rider weight (SX-E 3)	15 ... 35 kg (33 ... 77 lb.)
Standard rider weight (SX-E 5)	25 ... 35 kg (55 ... 77 lb.)

- If the rider's weight is above or below this range, the basic setting of the suspension components must be adjusted accordingly.
- Small weight differences can be compensated by adjusting the spring preload and the fork air pressure, but in the case of larger weight differences, the springs must be replaced.

11.2 Air suspension (SX-E 5)

Air suspension is used in this fork.

In this system, the suspension is located in the left fork leg and damping in the right fork leg.

A significant weight advantage is achieved compared with conventional forks. The response on slightly uneven surfaces is significantly improved.

In normal driving mode, suspension is provided exclusively by an air cushion. A steel spring is located in the left fork leg as an end stop.

i Info

If the fork is frequently overloaded, then the air pressure in the fork must be increased to avoid damage to the fork and frame.

The air pressure in the fork can be quickly adjusted to the rider's weight, surface conditions and the rider's preference using a fork airpump. The fork does not have to be dismantled. The time consuming mounting of harder or softer fork springs is not required.

If the air chamber loses air due to a damaged seal, the fork will still not sag. In this case the air is retained in the fork. The suspension travel is maintained as far as possible. The damping becomes harder and the riding comfort reduces.

The rebound damping can be adjusted.

The rebound adjustment is located at the upper end of the right fork leg.

11.3 Compression damping of the shock absorber (SX-E 5)

The compression damping of the shock absorber is divided into two ranges: high-speed and low-speed. High-speed and low-speed refer to the compression speed of the rear wheel suspension and not to the vehicle speed.

The high-speed compression adjuster has an effect, for example, when landing after a jump: the rear wheel suspension compresses quickly.

The low-speed compression adjuster has an effect, for example, when riding over long ground swells: the rear wheel suspension compresses slowly.

These two ranges can be adjusted separately, although the transition between high-speed and low-speed is gradual. Thus, modifications in the high-speed range affect the compression damping in the low-speed range and vice versa.

11.4 Adjusting the low-speed compression damping of the shock absorber (SX-E 5)



Caution

Risk of injury Parts of the shock absorber will move around if the shock absorber is detached incorrectly.

The shock absorber is filled with highly compressed nitrogen.

- Please follow the description provided. (Your authorized KTM workshop will be glad to help.)



Info

The effect of the low-speed compression adjuster can be seen in slow to normal compression of the shock absorber.

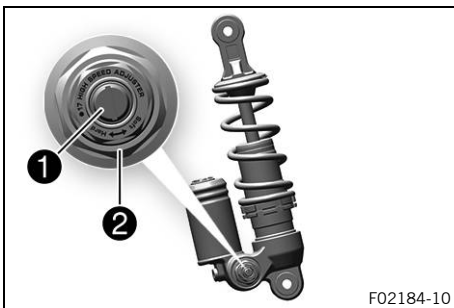

- Turn adjusting screw ① clockwise with a screwdriver as far as the last perceptible click.



Info

Do not loosen fitting ②!

- Turn counterclockwise by the number of clicks corresponding to the shock absorber type.

Guideline

Low-speed compression damping	
Comfort	18 clicks
Standard	15 clicks
Sport	12 clicks



Info

Turn clockwise to increase damping; turn counterclockwise to reduce damping.

11.5 Adjusting the high-speed compression damping of the shock absorber (SX-E 5)



Caution

Risk of injury Parts of the shock absorber will move around if the shock absorber is detached incorrectly.

The shock absorber is filled with highly compressed nitrogen.

- Please follow the description provided. (Your authorized KTM workshop will be glad to help.)



Info

The effect of the high speed compression adjuster can be seen in the fast compression of the shock absorber.

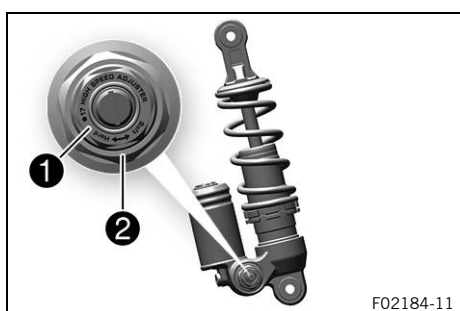

- Push the splash protector to the side.
- Using an open end wrench, turn adjusting screw ❶ clockwise all the way.



Info

Do not loosen fitting ❷!

- Turn counterclockwise by the number of turns corresponding to the shock absorber type.

Guideline

High-speed compression damping	
Comfort	2.5 turns
Standard	2 turns
Sport	1.5 turns



Info

Turn clockwise to increase damping; turn counterclockwise to reduce damping.

- Position the splash protector.

11.6 Adjusting the rebound damping of the shock absorber (SX-E 5)



Caution

Risk of injury Parts of the shock absorber will move around if the shock absorber is detached incorrectly.

The shock absorber is filled with highly compressed nitrogen.

- Please follow the description provided. (Your authorized KTM workshop will be glad to help.)

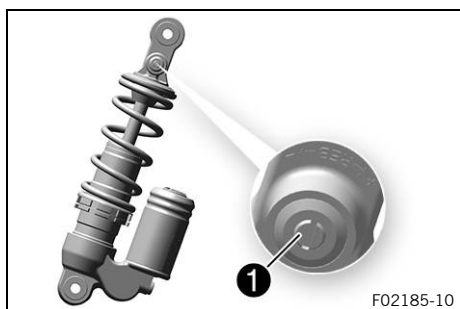

- Turn adjusting screw ❶ clockwise up to the last perceptible click.
- Turn counterclockwise by the number of clicks corresponding to the shock absorber type.

Guideline

Rebound damping	
Comfort	17 clicks
Standard	15 clicks
Sport	13 clicks



Info

Turn clockwise to increase the damping; turn counter-clockwise to reduce damping when the shock absorber rebounds.

11.7 Measuring the dimension of the rear wheel unloaded (SX-E 5)

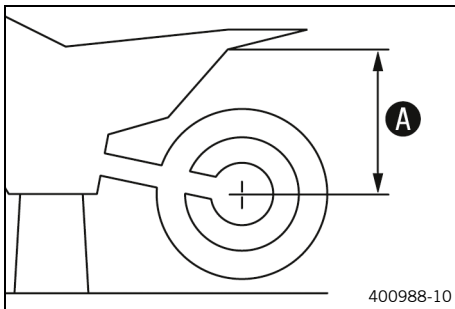

Preparatory work

- Raise the motorcycle with a lift stand. (📖 p. 46)

Main work

- Measure the vertical distance between the rear axle and a fixed point, such as a marking on the side cover.
- Note the value as dimension **A**.

Finishing work

- Remove the motorcycle from the lift stand. (📖 p. 46)

11.8 Checking the static sag of the shock absorber (SX-E 5)

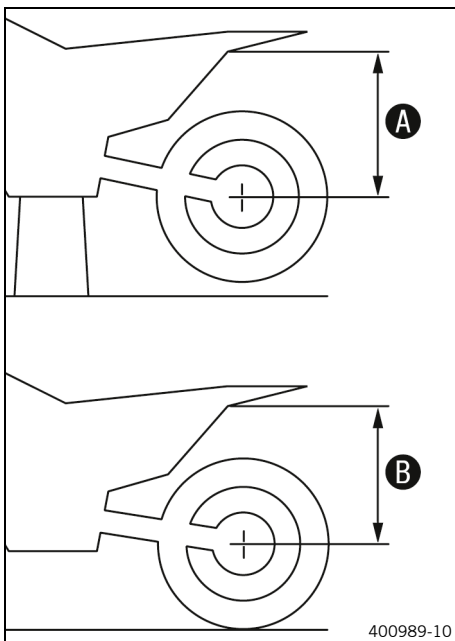

- Measure dimension **A** of rear wheel unloaded. (📖 p. 33)
- Hold the motorcycle upright with aid of an assistant.
- Measure the distance between rear axle and fixed point again.
- Note the value as dimension **B**.



Info

The static sag is the difference between measurements **A** and **B**.

- Check the static sag.

Static sag	12 mm (0.47 in)
------------	-----------------

- » If the static sag is less or more than the specified value:
 - Adjust the spring preload of the shock absorber. (📖 p. 34)

11.9 Checking the riding sag of the shock absorber (SX-E 5)

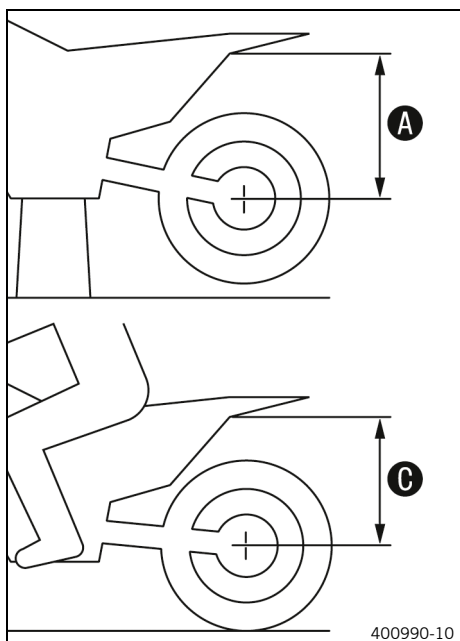

- Measure dimension **A** of rear wheel unloaded. (📖 p. 33)
- With another person holding the motorcycle, the rider, wearing full protective clothing, sits on the seat in a normal sitting position (feet on footrests) and bounces up and down a few times.
 - ✓ The rear wheel suspension levels out.
- Another person now measures the distance between the rear axle and the fixed point.
- Note the value as dimension **C**.



Info

The riding sag is the difference between measurements **A** and **C**.

- Check riding sag.

Rider sag	80 mm (3.15 in)
-----------	-----------------

- » If the riding sag differs from the specified measurement:
 - Adjust the riding sag. (🔧📖 p. 35)

11.10 Adjusting the spring preload of the shock absorber 🛠️



Caution

Risk of injury Parts of the shock absorber will move around if the shock absorber is detached incorrectly.

The shock absorber is filled with highly compressed nitrogen.

- Please follow the description provided. (Your authorized KTM workshop will be glad to help.)

Preparatory work

(SX-E 5)

- Raise the motorcycle with a lift stand. (📖 p. 46)
- Remove the shock absorber. (🔧📖 p. 57)
- After removing the shock absorber, clean it thoroughly.

Main work

(SX-E 3)

- Adjust the spring preload by turning adjusting ring **1**.

Guideline

Spring preload	
Standard	3 clicks

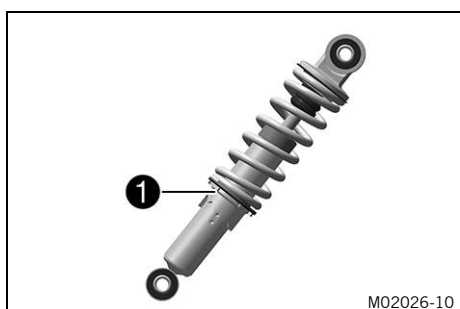

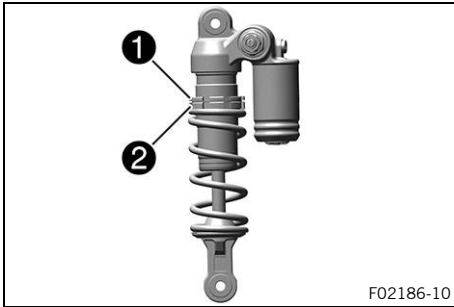

(SX-E 5)

- Measure the full spring length while it is under tension and note down the value.
- Loosen retaining ring ①.
- Turn adjusting ring ② until the spring is no longer under tension.

Hook wrench (T304)
Hook wrench (T1533)

i Info
If the spring cannot be fully released, the spring must be removed to accurately measure the spring length.

- Measure the total spring length while the spring is not under tension.
- Tighten the spring to the specified measurement by turning adjusting ring ②.

Guideline

Spring preload	3 mm (0.12 in)
----------------	----------------

i Info
The spring preload is the difference between the relaxed spring length and the tensioned spring length.
Depending on the static sag and/or the riding sag, it may be necessary to increase or decrease the spring preload.

- Tighten retaining ring ①.

Finishing work

(SX-E 5)

- Install the shock absorber. 🛠️ (📖 p. 57)
- Remove the motorcycle from the lift stand. (📖 p. 46)

11.11 Adjusting the riding sag 🛠️

Preparatory work

- Raise the motorcycle with a lift stand. (📖 p. 46)
- Remove the shock absorber. 🛠️ (📖 p. 57)
- After removing the shock absorber, clean it thoroughly.

Main work

(SX-E 3)

- Select and mount a suitable shock absorber.

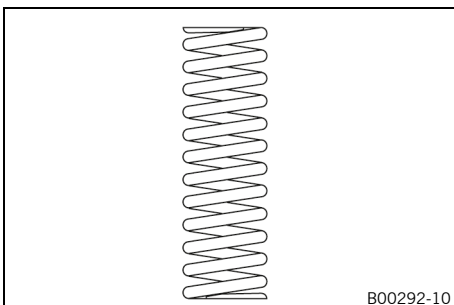

Guideline

Spring rate	
"Comfort" variant	30 N/mm (171 lb/in)
"Standard" variant	35 N/mm (200 lb/in)
"Sport" variant	40 N/mm (228 lb/in)

i Info
The spring rate can only be changed by replacing the shock absorber.

i Info
Smaller weight differences can be compensated by changing the spring preload.

(SX-E 5)

- Select and mount a suitable spring.

Guideline

Spring rate	
Weight of rider: 15 ... 25 kg (33 ... 55 lb.)	25 N/mm (143 lb/in)
Weight of rider (standard): 25 ... 35 kg (55 ... 77 lb.)	30 N/mm (171 lb/in)
Weight of rider: 35 ... 45 kg (77 ... 99 lb.)	35 N/mm (200 lb/in)

i Info
The spring rate is shown on the outside of the spring.
Smaller weight differences can be compensated by changing the spring preload.

Finishing work

- Install the shock absorber. (🔧 p. 57)
- Remove the motorcycle from the lift stand. (🔧 p. 46)

(SX-E 5)

- Check the static sag of the shock absorber. (🔧 p. 33)

(SX-E 5)

- Check the riding sag of the shock absorber. (🔧 p. 34)

(SX-E 5)

- Adjust the rebound damping of the shock absorber. (🔧 p. 32)

11.12 Checking the basic setting of the fork (SX-E 5)

i Info

For various reasons, no exact riding sag can be determined for the fork.

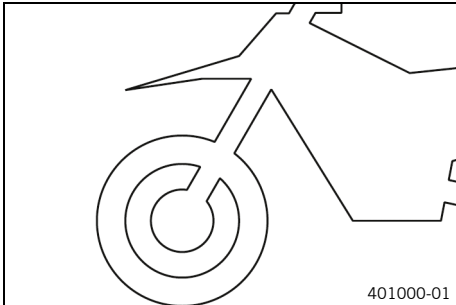

- Smaller differences in the rider's weight can be compensated for by the fork air pressure.
- However, if the fork frequently bottoms out (hard end stop on compression), the fork air pressure must be increased, within the specified values, to avoid damage to the fork and frame.

11.13 Adjusting the fork air pressure (SX-E 5)



Warning

Danger of accidents Modifications to the suspension setting may seriously alter the handling characteristic.

Modifications which are not coordinated with others to the suspension setting may cause a serious deterioration in the handling characteristic and overload components.

- Only make adjustments within the recommended range.
- Make sure your child rides slowly to start with after making adjustments in order that he or she can assess the new handling characteristic.

i Info

Check or adjust the air pressure 5 minutes, at the earliest, after the end of the ride and under the same conditions.

The air suspension is located in the left fork leg. The rebound damping is located in the right fork leg.

Preparatory work

- Raise the motorcycle with a lift stand. (📖 p. 46)

Main work

- Remove protection cap **1**.
- Push together fork airpump **2** fully.

Fork airpump (79412966100)

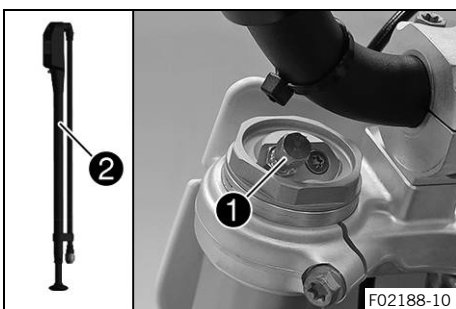

Info

The fork airpump is included as part of the motorcycle's accessory pack.

- Connect the fork airpump to the left fork leg.
 - ✓ The fork airpump indicator switches on automatically.
 - ✓ A little air escapes from the fork leg when connecting.

i Info

This is due to the volume of the hose and not due to a defect in the fork airpump or the fork.
Read the accompanying instructions.

- Adjust the air pressure as specified.

Guideline

Air pressure	1 bar (15 psi)
Gradual changing of the air pressure in steps of	0.2 bar (3 psi)
Minimum air pressure	0.5 bar (7 psi)
Maximum air pressure	5 bar (73 psi)

i Info

Never adjust the air pressure to a value outside the stated range.

- Disconnect the fork airpump from the left fork leg.
 - ✓ When disconnecting, excess pressure will escape from the hose – the fork leg itself does not lose any air.
 - ✓ The fork airpump indicator switches off automatically after 80 seconds.
- Mount the protection cap.

i Info

Only mount the protection cap by hand.

Finishing work

- Remove the motorcycle from the lift stand. (📖 p. 46)

11.14 Adjusting the rebound damping of the fork (SX-E 5)

i Info

The hydraulic rebound damping determines the fork suspension behavior.



- Turn adjuster **1** clockwise all the way to the stop.

i Info

Adjuster **1** is located at the upper end of the right fork leg.

- Turn counterclockwise by the number of clicks corresponding to the fork type.

Guideline

Rebound damping	
Comfort	15 clicks
Standard	12 clicks
Sport	10 clicks



Info

Turn clockwise to increase the damping; turn counter-clockwise to reduce damping when the shock absorber rebounds.

11.15 Handlebar position

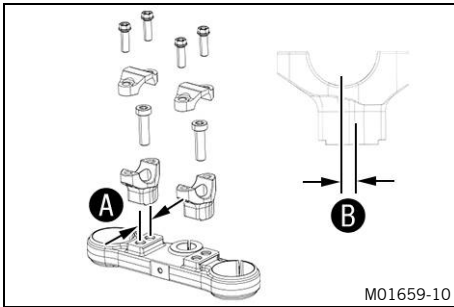

On the upper triple clamp, there are 2 holes at a distance of **A** to each other.

Hole distance A	15 mm (0.59 in)
------------------------	-----------------

The holes on the handlebar support are placed at a distance of **B** from the center.

Hole distance B	3.5 mm (0.138 in)
------------------------	-------------------

The handlebar holder can be mounted in four different positions. This allows the handlebar to be mounted in the most comfortable position for the rider.

11.16 Adjusting the handlebar position



Warning

Danger of accidents A repaired handlebar poses a safety risk.

If the handlebar is bent or straightened, the material becomes fatigued. The handlebar may break as a result.

- Change the handlebar if the handlebar is damaged or bent.

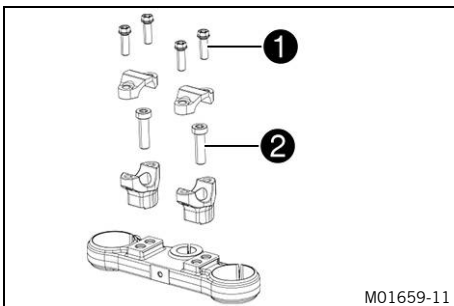

- Remove screws **1**. Take off the handlebar clamps. Remove the handlebar and lay it to one side.



Info

Cover the components to protect them against damage. Do not kink the cables and lines.

- Remove screws **2**. Take off handlebar supports.
- Place handlebar supports in required position. Mount and tighten screws **2**.

Guideline

Screw, handlebar support	M10	40 Nm (29.5 lbf ft) Loctite®243™
--------------------------	-----	--

Mount the left and right handlebar supports in the same position.

- Position the handlebar.



Info

Make sure the cables and wiring are positioned correctly.

- Position the handlebar clamps. Mount screws **1** and tighten evenly.

11 SUSPENSION SETTING

Guideline

Screw, handlebar clamp	M8	20 Nm (14.8 lbf ft)
------------------------	----	---------------------



Info

Make sure the installed gaps are even.

12.1 Seat height adjustment options

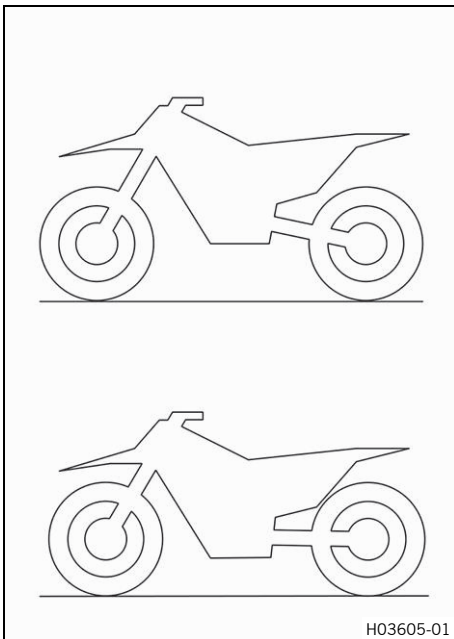

This vehicle offers several options for adjusting the seat height to the rider's height. The seat height can be changed with the mounting position of the fork, shock absorber, and frame.

i Info

When adjusting the seat height on the fork and shock absorber, make sure that the vehicle is as straight as possible after completion of the work. If the seat height on the shock absorber is set low, the fork should be pushed through further and vice versa.

12.2 Adjusting the seat height on the shock absorber ↩



Warning

Danger of accidents Modifications to the suspension setting may seriously alter the handling characteristic.

- Make sure your child rides slowly to start with after making adjustments in order that he or she can assess the new handling characteristic.



Info

If the seat height is adjusted on the shock absorber, the seat height should also be adjusted on the fork.

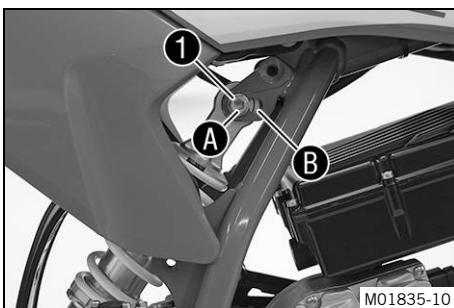

Preparatory work

- Raise the motorcycle with a lift stand. (📖 p. 46)

Main work

- Hold the rear wheel with the link fork and remove screw ①.
- Position the shock absorber according to the required seat height.

Guideline

High seat position	A
Low seat position	B

- Mount and tighten screw ①.

Guideline

Screw, top shock absorber	M10x42	45 Nm (33.2 lbf ft) Loctite®243™
---------------------------	--------	--

Finishing work

- Remove the motorcycle from the lift stand. (📖 p. 46)

12.3 Adjusting the seat height on the fork 🛠️



Warning

Danger of accidents Modifications to the suspension setting may seriously alter the handling characteristic.

- Make sure your child rides slowly to start with after making adjustments in order that he or she can assess the new handling characteristic.



Info

The seat height can be infinitely adjusted by pushing the fork legs through.

If the seat height is adjusted on the fork, the seat height should also be adjusted on the shock absorber.

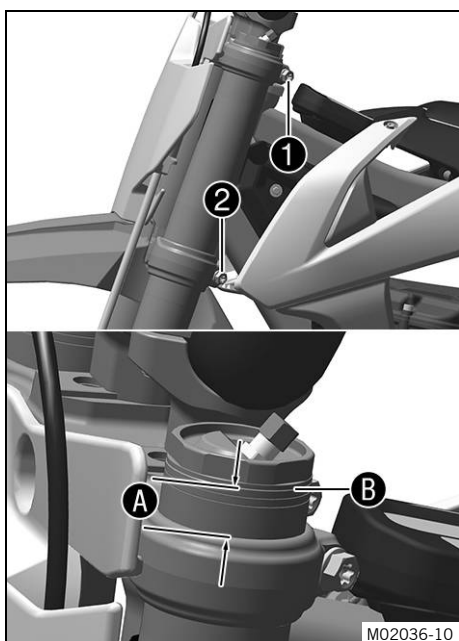

Preparatory work

- Raise the motorcycle with a lift stand. (📖 p. 46)
- Remove the front wheel. 🛠️ (📖 p. 82)

Main work

- Loosen screw ①.
- Loosen screw ②.
- Position the fork leg according to the required seat height.

Guideline

Condition

Seat position as low as possible, fork fully inserted

Maximum distance A between lower edge of screw cap and upper edge of triple clamp	18 mm (0.71 in)
--	-----------------

Condition

Seat position as high as possible, fork pulled out completely

Bottom edge of screw cap B closes flush with the upper edge of the triple clamp
--

Position the fork leg only within the described range.
--

- Tighten screw ②.

Guideline

Screw, bottom triple clamp	M8	15 Nm (11.1 lbf ft)
----------------------------	----	---------------------

- Tighten screw ①.

Guideline

Screw, top triple clamp	M8	20 Nm (14.8 lbf ft)
-------------------------	----	---------------------

- Repeat the procedure on the other fork leg.

Guideline

Position both fork legs equally.

Finishing work

- Install the front wheel. 🛠️ (📖 p. 82)

12.4 Adjusting the seat height on the frame ↩

Preparatory work

- Remove the seat. (📖 p. 58)

Main work

- Remove screw ① and the front fairing.

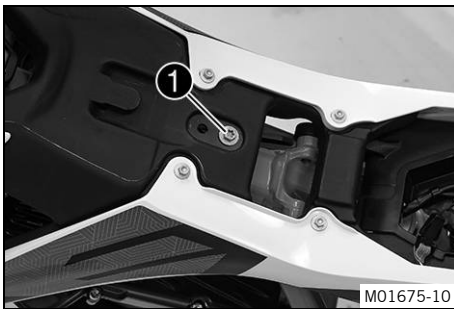

M01675-10

- Remove screws ② with bushings and splash protector ③.
- Remove screws ④ with bushings and rear fairing ⑤.

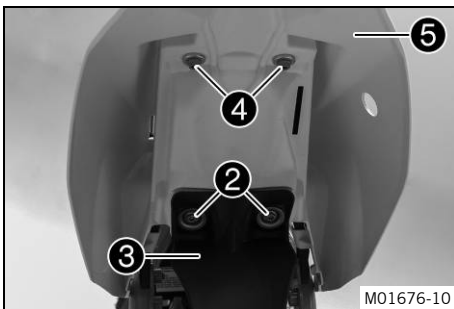

M01676-10

- Remove screws ⑥ and position subframe ⑦ at the drill holes at the desired seat height.

Guideline

Pay attention to the wiring harness.	
High seat position	Drill holes A
Low seat position	Drill holes B

- Mount and tighten screws ⑥.

Guideline

Screw, sub-frame	M8	30 Nm (22.1 lbf ft) Loctite®243™
------------------	----	--

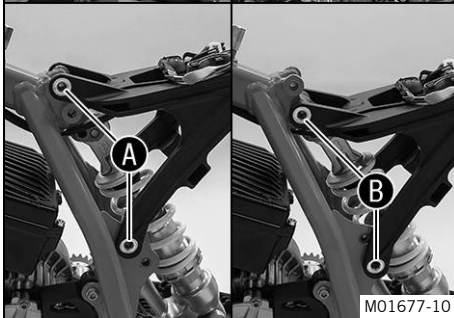
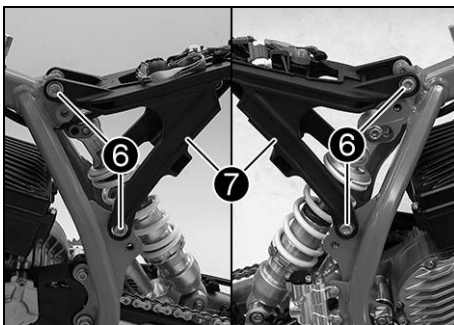

M01677-10

- Position rear fairing ⑤, mount screws ④ with bushings, and tighten.

Guideline

Rear fairing screw	M6	8 Nm (5.9 lbf ft)
--------------------	----	-------------------

- Position splash protector ③, mount screws ② with bushings, and tighten.

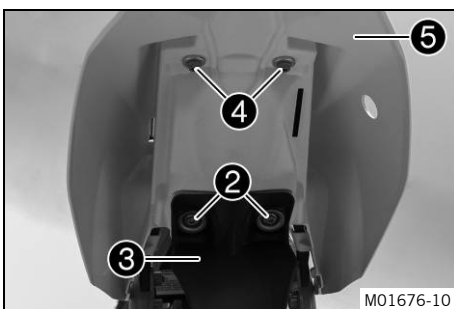

M01676-10

Guideline

Screw, splash protector	M6	7 Nm (5.2 lbf ft)
-------------------------	----	-------------------

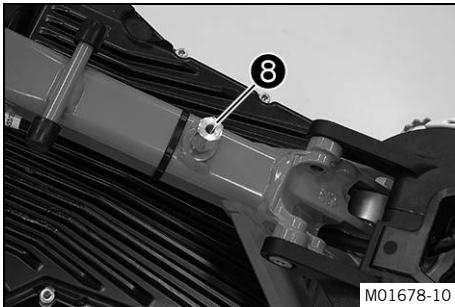

Condition

High seat position

- Make sure that thread adapter **8** is mounted and tightened.

Guideline

Threaded adapter for front fairing	M6	8 Nm (5.9 lbf ft)
------------------------------------	----	-------------------

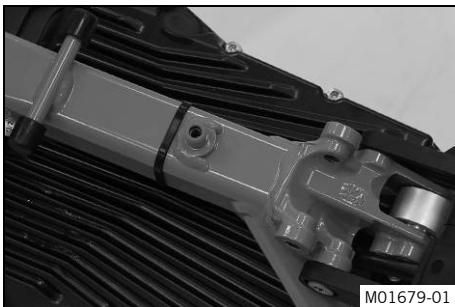

Condition

Low seat position

- Make sure that the thread adapter is removed.



Info

Retain the thread adapter for later assembly.

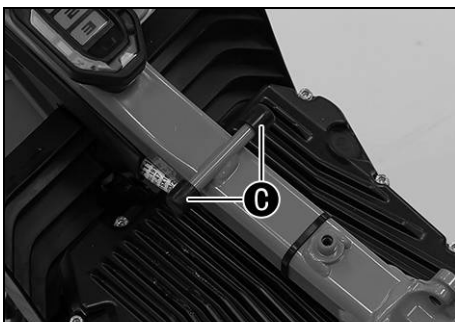

- Position the front fairing on holders **C**.

- ✓ The holding lugs of the front fairing engage in the recesses of the rear fairing on both sides.

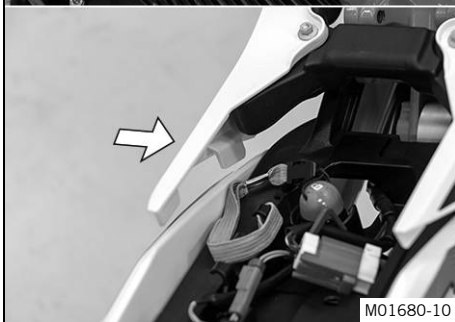

- Mount and tighten screw **1**.

Guideline

Remaining screws, chassis	M6	10 Nm (7.4 lbf ft)
---------------------------	----	--------------------

Finishing work

- Mount the seat. (📖 p. 59)



13.1 Raising the motorcycle with a lift stand

Note

Danger of damage The parked vehicle can roll away or fall over.

- Park the vehicle on a firm and level surface.

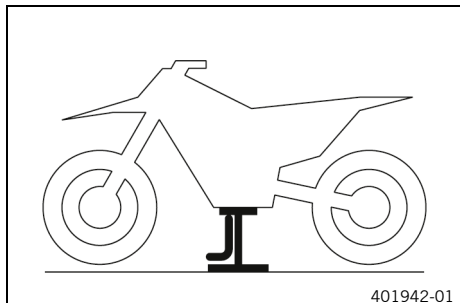

- Raise the motorcycle at the frame underneath the engine.

Lift stand (78929955100)

- ✓ Neither wheel is in contact with the ground.
- Secure the motorcycle against falling over.

13.2 Removing the motorcycle from the lift stand

Note

Danger of damage The parked vehicle can roll away or fall over.

- Park the vehicle on a firm and level surface.

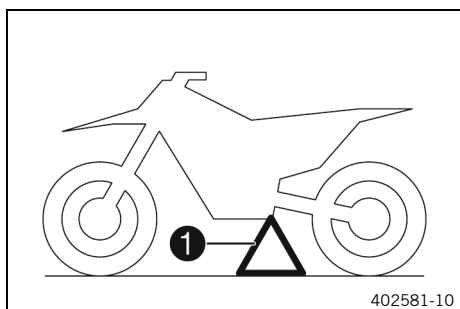

- Remove the motorcycle from the lift stand.
- Remove the lift stand.
- To park the motorcycle, insert plug-in stand ① into the plug-in stand bracket on the left side of the vehicle.

Info

Remove the plug-in stand before riding.

13.3 Bleeding the fork legs

Preparatory work

- Raise the motorcycle with a lift stand. (📖 p. 46)

Main work (SX-E 3)

- Release bleeder screws ①.
- ✓ Any excess pressure escapes from the interior of the fork.
- Tighten the bleeder screws.

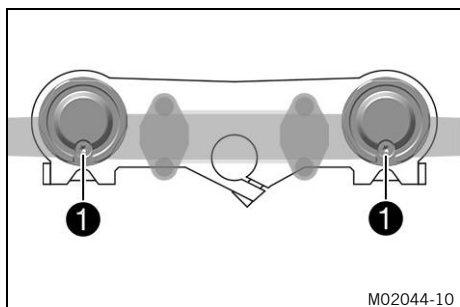

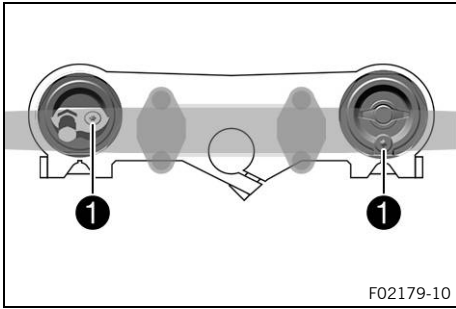

(SX-E 5)

- Release bleeder screws ①.
- ✓ Any excess pressure escapes from the interior of the fork.
- Tighten the bleeder screws.

Finishing work

- Remove the motorcycle from the lift stand. (📖 p. 46)

13.4 Cleaning the dust boots of the fork legs

Preparatory work

- Raise the motorcycle with a lift stand. (📖 p. 46)
- Remove the fork protector. (📖 p. 48)

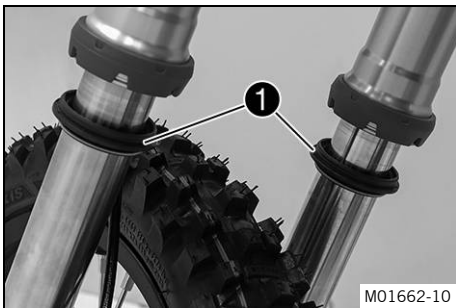

Main work

- Push dust boots ① of both fork legs downward.



Info

The dust boots remove dust and coarse dirt particles from the inside fork tubes. Over time, dirt can accumulate behind the dust boots. If this dirt is not removed, the seals rings behind can start to leak.



Warning

Danger of accidents Oil or grease on the brake discs reduces the braking effect.

- Always keep the brake discs free of oil and grease.
- Clean the brake discs with brake cleaner when necessary.

- Clean and oil the dust boots and inside fork tubes of both fork legs.

Universal oil spray (📖 p. 106)

- Press the dust boots back into the installation position.
- Remove the excess oil.

Finishing work

- Install the fork protector. (📖 p. 48)
- Remove the motorcycle from the lift stand. (📖 p. 46)

13.5 Removing the fork protector

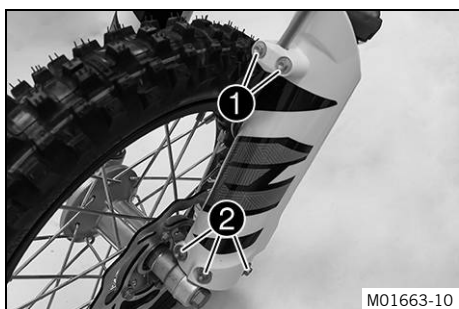

- Remove screws **1** and take off the clamp.
- Remove screws **2** on the left and right rear fork leg. Take off the fork protector.

13.6 Installing the fork protector

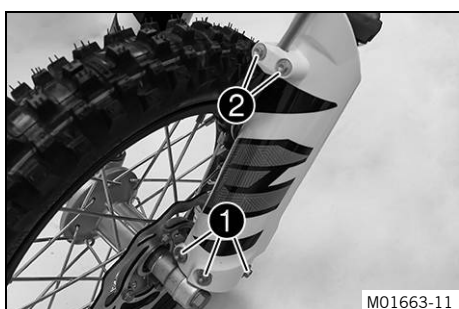

- Position the fork protector on the left and right fork leg. Mount and tighten screws **1**.

Guideline

Remaining screws, chassis	M6	10 Nm (7.4 lbf ft)
---------------------------	----	--------------------

- Position the brake line and the clamp. Mount and tighten screws **2**.

Guideline

Screw, brake line holder on fork protector	EJOT PT® K60x20-AL	2 Nm (1.5 lbf ft)
--	-------------------------------	-------------------

13.7 Removing the fork legs

Preparatory work

- Raise the motorcycle with a lift stand. (📖 p. 46)
- Remove the front wheel. 🛠️ (📖 p. 82)

Main work

- Remove screws **1** and take off the clamp.
- Remove screws **2** and take off the brake caliper.
- Allow the brake caliper and the brake line to hang loosely to the side.



Info

Do not kink the brake line.

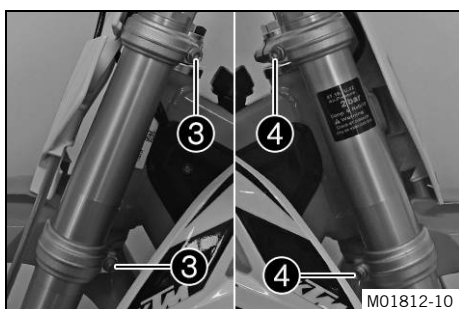
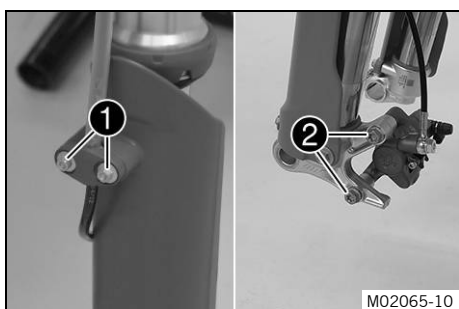

- Note the installation position of the fork legs.
- Loosen screws **3**. Remove the left fork leg.
- Loosen screws **4**. Remove the right fork leg.

13.8 Installing the fork legs

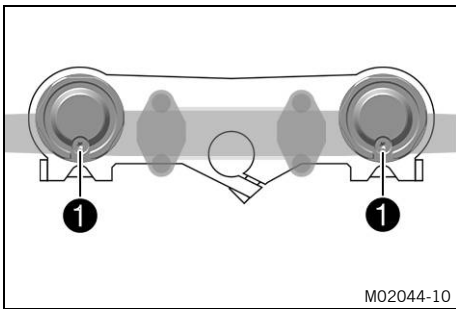

Condition

Individual installation position

(SX-E 3)

- Position the fork legs.

Guideline

Observe the position determined during removal.

- ✓ Bleeder screws ① are positioned toward the rear.

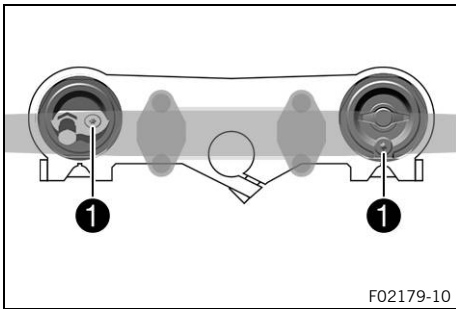

(SX-E 5)

- Position the fork legs.

Guideline

Observe the position determined during removal.

- ✓ Bleeder screws ① are positioned toward the rear.

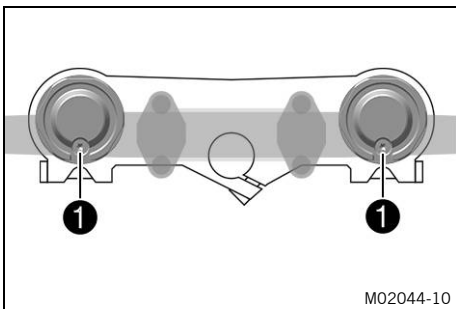

Condition

Standard installation position

(SX-E 3)

- Position the fork legs.

- ✓ Bleeder screws ① are positioned toward the rear.

- ✓ The second milled groove (from the top) is flush with the upper edge of the upper triple clamp.

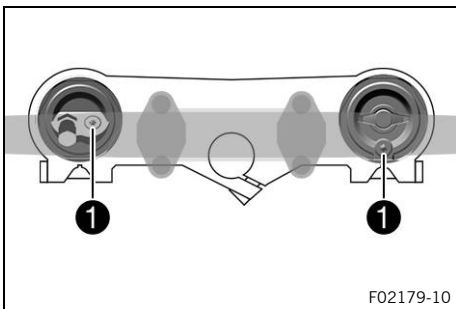

(SX-E 5)

- Position the fork legs.

- ✓ Bleeder screws ① are positioned toward the rear.

- ✓ The second milled groove (from the top) is flush with the upper edge of the upper triple clamp.

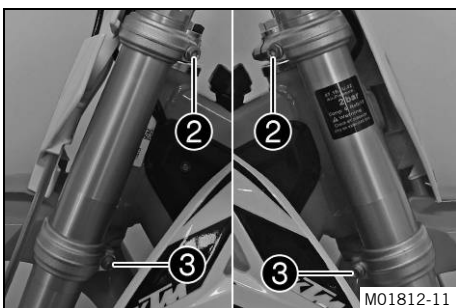

- Tighten screws ②.

Guideline

Screw, top triple clamp	M8	20 Nm (14.8 lbf ft)
-------------------------	----	---------------------

- Tighten screws ③.

Guideline

Screw, bottom triple clamp	M8	15 Nm (11.1 lbf ft)
----------------------------	----	---------------------

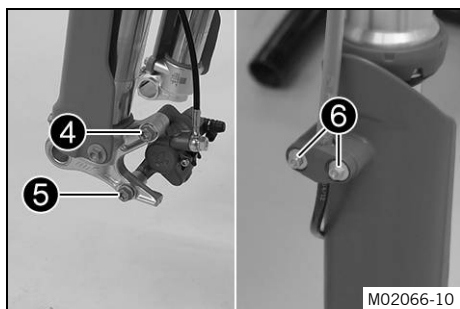

- Position the brake caliper, mount screw ④, and tighten.

Guideline

Screw, front brake caliper	M8x35	20 Nm (14.8 lbf ft) Loctite®243™
----------------------------	-------	--

- Mount and tighten screw ⑤.

Guideline

Screw, front brake caliper	M8x35	20 Nm (14.8 lbf ft) Loctite®243™
----------------------------	-------	--

- Position the brake line and the clamp. Mount and tighten screws ⑥.

Guideline

Screw, brake line holder on fork protector	EJOT PT® K60x20-AL	2 Nm (1.5 lbf ft)
--	-------------------------------	-------------------

Finishing work

- Install the front wheel. 🛠️ (📖 p. 82)

13.9 Removing the lower triple clamp 🛠️

Preparatory work

- Raise the motorcycle with a lift stand. (📖 p. 46)
- Remove the front wheel. 🛠️ (📖 p. 82)
- Remove the fork legs. 🛠️ (📖 p. 48)
- Remove the start number plate. (📖 p. 55)
- Remove front fender. (📖 p. 56)



Main work

- Remove nut ①.
- Remove the cable tie on the magnetic switch cable from the handlebar.
- Release screw ②, take off the upper triple clamp with the handlebar and set aside.

Info

Cover the components to protect them against damage. Do not kink the cables and lines.

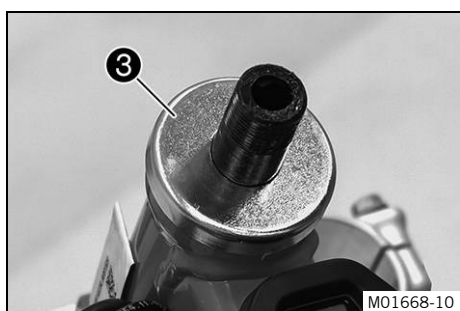

- Remove protective ring ③.
- Remove the lower triple clamp with the steering stem.
- Remove the upper steering head bearing.

13.10 Installing the lower triple clamp

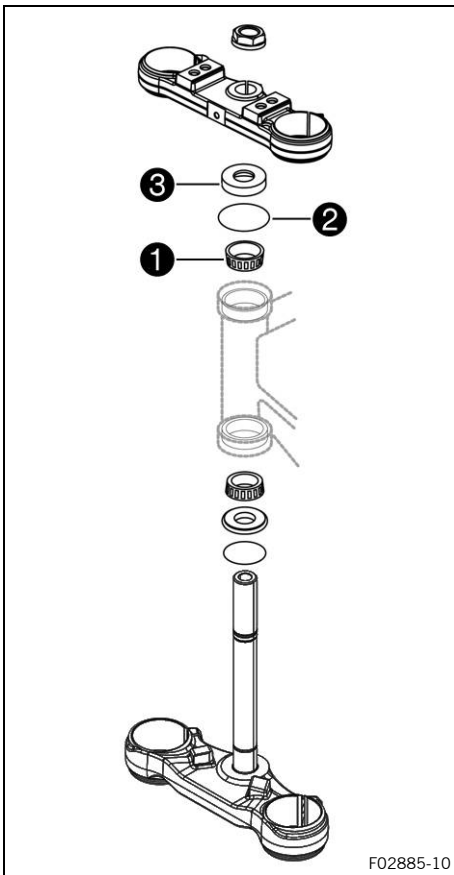

Main work

- Clean the bearing and sealing elements, check for damage, and grease.

High viscosity grease (p. 106)

- Insert the lower triple clamp with the steering stem. Mount upper steering head bearing ①.
- Check that the O-ring at the top ② is correctly positioned.
- Push on protective ring ③.

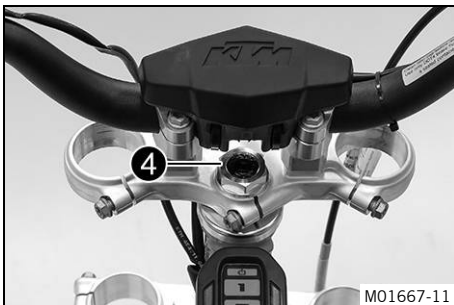

- Position the upper triple clamp and handlebar.
- Mount nut ④, but do not tighten yet.

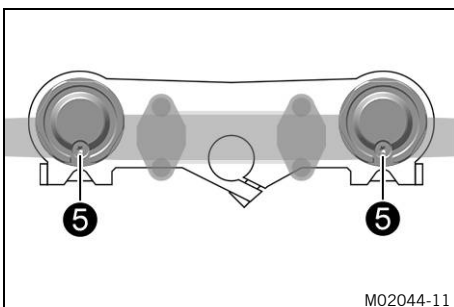

Condition

Individual installation position

(SX-E 3)

- Position the fork legs.

Guideline

Observe the position determined during removal.

- ✓ Bleeder screws ⑤ are positioned toward the rear.

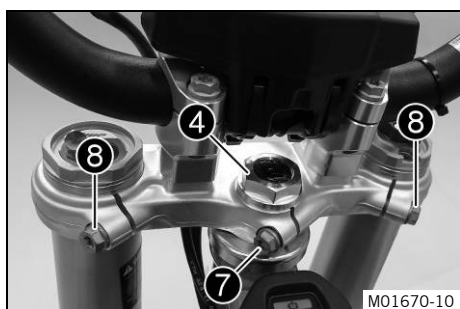
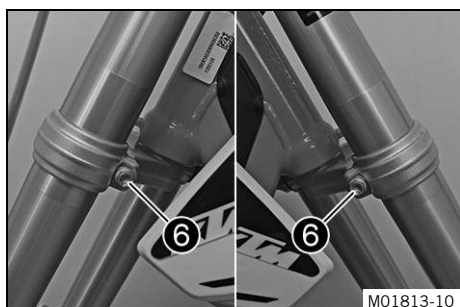
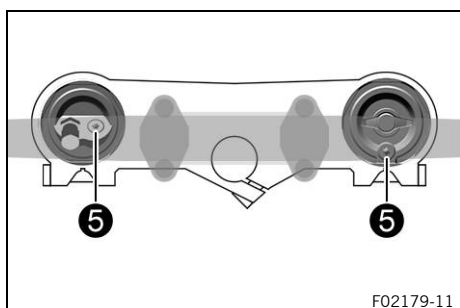
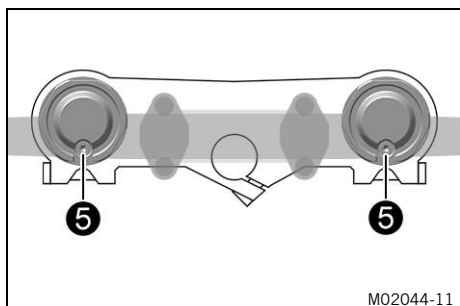
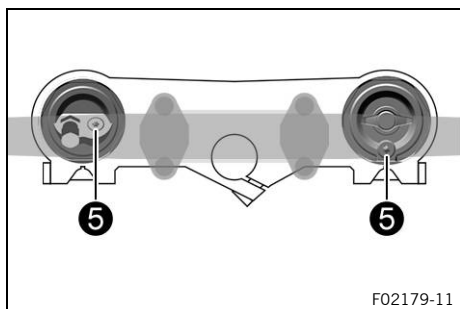

(SX-E 5)

- Position the fork legs.

Guideline

Observe the position determined during removal.

- ✓ Bleeder screws (5) are positioned toward the rear.

Condition

Standard installation position

(SX-E 3)

- Position the fork legs.

- ✓ Bleeder screws (5) are positioned toward the rear.

- ✓ The second milled groove (from the top) is flush with the upper edge of the upper triple clamp.

(SX-E 5)

- Position the fork legs.

- ✓ Bleeder screws (5) are positioned toward the rear.

- ✓ The second milled groove (from the top) is flush with the upper edge of the upper triple clamp.

- Tighten screws (6).

Guideline

Screw, bottom triple clamp	M8	15 Nm (11.1 lbf ft)
----------------------------	----	---------------------

- Tighten nut (4).

Guideline

Nut, steering head	M20x1.5	10 Nm (7.4 lbf ft)
--------------------	---------	--------------------

- Tighten screw (7).

Guideline

Screw, top triple clamp	M8	20 Nm (14.8 lbf ft)
-------------------------	----	---------------------

- Using a plastic hammer, tap lightly on the upper triple clamp to avoid stresses.

- Tighten screws (8).

Guideline

Screw, top triple clamp	M8	20 Nm (14.8 lbf ft)
-------------------------	----	---------------------

- Fix the magnetic switch cable to the handlebar with a new cable tie.

- Position the brake caliper, mount screw ⑨, and tighten.

Guideline

Screw, front brake caliper	M8x35	20 Nm (14.8 lbf ft) Loctite®243™
----------------------------	-------	--

- Mount and tighten screw ⑩.

Guideline

Screw, front brake caliper	M8x35	20 Nm (14.8 lbf ft) Loctite®243™
----------------------------	-------	--

- Position the brake line and the clamp. Mount and tighten screws ⑪.

Guideline

Screw, brake line holder on fork protector	EJOT PT® K60x20-AL	2 Nm (1.5 lbf ft)
--	-------------------------------	-------------------

Finishing work

- Install front fender. (📖 p. 56)
- Install the start number plate. (📖 p. 55)
- Check that the cable and brake line are routed correctly.
- Install the front wheel. 🛠️ (📖 p. 82)
- Check the steering head bearing play. (📖 p. 53)
- Remove the motorcycle from the lift stand. (📖 p. 46)

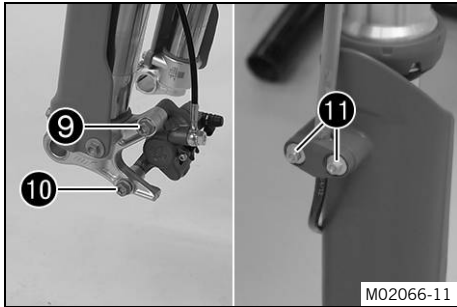

13.11 Checking the steering head bearing play



Warning

Danger of accidents Incorrect steering head bearing play impairs the handling characteristic and damages components.

- Correct incorrect steering head bearing play immediately. (Your authorized KTM workshop will be glad to help.)



Info

If the vehicle is operated for a lengthy period with play in the steering head bearing, the bearings and the bearing seats in the frame can become damaged over time.

Preparatory work

- Raise the motorcycle with a lift stand. (📖 p. 46)

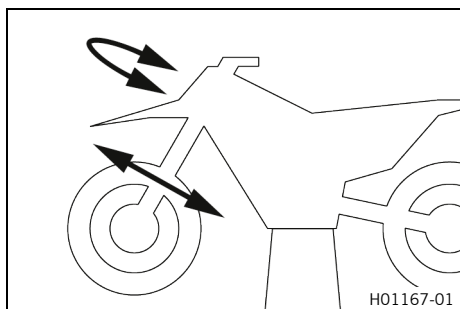

Main work

- Move the handlebar to the straight-ahead position. Move the fork legs to and fro in the direction of travel.

Play should not be detectable on the steering head bearing.

- » If there is detectable play:
 - Adjust the steering head bearing play. 🛠️ (📖 p. 54)

- Move the handlebar to and fro over the entire steering range.

It must be possible to move the handlebar easily over the entire steering range. There should be no detectable detent positions.

- » If detent positions are detected:
 - Adjust the steering head bearing play. 🛠️ (📖 p. 54)
 - Check the steering head bearing and replace if required.

Finishing work

- Remove the motorcycle from the lift stand. (📖 p. 46)

13.12 Adjusting the steering head bearing play 🛠️

Preparatory work

- Raise the motorcycle with a lift stand. (📖 p. 46)

Main work

(SX-E 3)

- Loosen screws ❶.
- Loosen screw ❷.
- Loosen and retighten nut ❸.

Guideline

Nut, steering head	M20x1.5	10 Nm (7.4 lbf ft)
--------------------	---------	--------------------

- Using a plastic hammer, tap lightly on the upper triple clamp to avoid stresses.
- Tighten screw ❷.

Guideline

Screw, top triple clamp	M8	20 Nm (14.8 lbf ft)
-------------------------	----	---------------------

- Tighten screws ❶.

Guideline

Screw, top triple clamp	M8	20 Nm (14.8 lbf ft)
-------------------------	----	---------------------

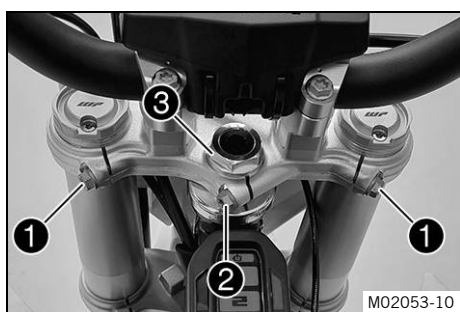

(SX-E 5)

- Loosen screws ❶.
- Loosen screw ❷.
- Loosen and retighten nut ❸.

Guideline

Nut, steering head	M20x1.5	10 Nm (7.4 lbf ft)
--------------------	---------	--------------------

- Using a plastic hammer, tap lightly on the upper triple clamp to avoid stresses.

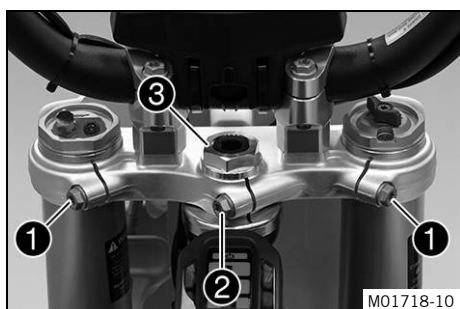

- Tighten screw ②.

Guideline

Screw, top triple clamp	M8	20 Nm (14.8 lbf ft)
-------------------------	----	------------------------

- Tighten screws ①.

Guideline

Screw, top triple clamp	M8	20 Nm (14.8 lbf ft)
-------------------------	----	------------------------

Finishing work

- Check the steering head bearing play. (📖 p. 53)
- Remove the motorcycle from the lift stand. (📖 p. 46)



13.13 Lubricating the steering head bearing 🛠️

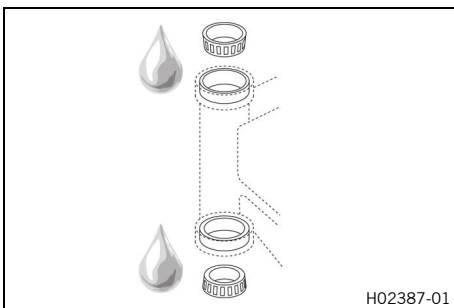

- Remove the lower triple clamp. 🛠️ (📖 p. 50)
- Install the lower triple clamp. 🛠️ (📖 p. 51)



Info

The steering head bearing is cleaned and lubricated in the course of removal and installation of the lower triple clamp.



13.14 Removing the start number plate

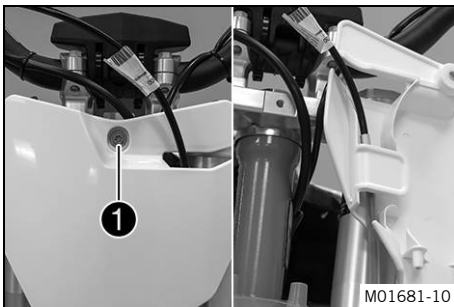

- Remove screw ①.
- Unhook the start number plate from the brake line and remove it.



13.15 Installing the start number plate

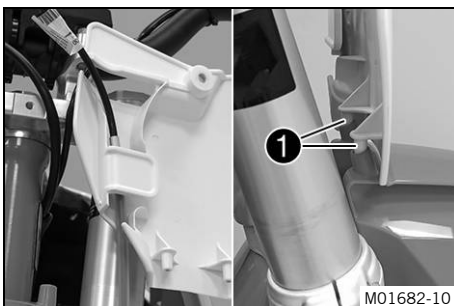

- Attach the start number plate to the brake line.
- Position the start number plate.
- ✓ Holding lugs ① engage in the fender.

13 SERVICE WORK ON THE CHASSIS

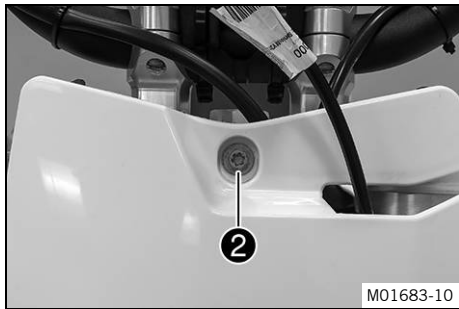

- Mount and tighten screw ②.

Guideline

Screw, start number plate	M6	4 Nm (3 lbf ft)
---------------------------	----	-----------------

13.16 Removing front fender

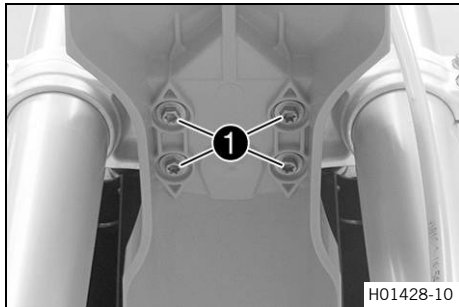

- Remove screws ①. Take off the front fender.

13.17 Installing front fender

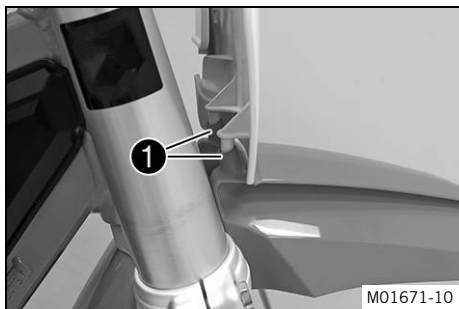

- Position the fender with drill holes ① in the holding lugs on the start number plate.

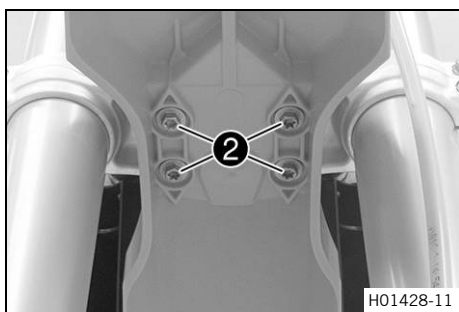

- Position front fender. Mount and tighten screws ②.

Guideline

Screw, fender	M6	6 Nm (4.4 lbf ft)
---------------	----	-------------------

13.18 Removing the shock absorber

Preparatory work

- Raise the motorcycle with a lift stand. (📖 p. 46)

Main work

(SX-E 3)

- Note the installation position of the shock absorber.
- Pull brake line ① out of the holder.
- Remove screw ② and lower the link fork carefully.
- Remove screw ③, push splash protector ④ to the side, and remove the shock absorber.

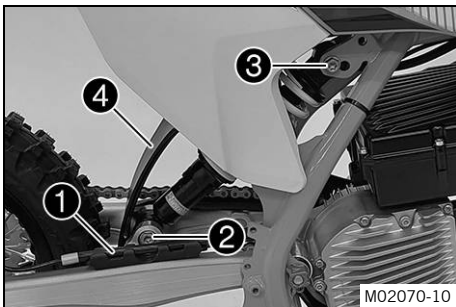

(SX-E 5)

- Note the installation position of the shock absorber.
- Pull brake line ① out of the holder.
- Remove screw ② and lower the link fork carefully.
- Remove screw ③, push splash protector ④ to the side, and remove the shock absorber.

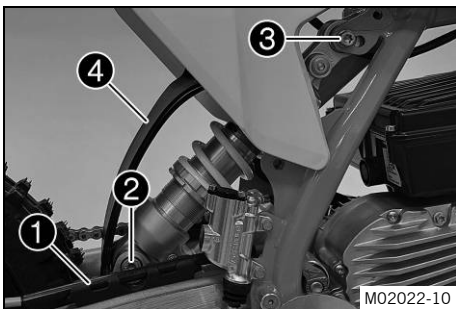

13.19 Installing the shock absorber



Warning

Danger of accidents Modifications to the suspension setting may seriously alter the handling characteristic.

- Make sure your child rides slowly to start with after making adjustments in order that he or she can assess the new handling characteristic.

Main work

(SX-E 3)

- Push splash protector ① to the side.
- Mount the shock absorber with screw ②.

Guideline

If necessary, observe the installation position noted during removal.

Screw, top shock absorber	M10x42	45 Nm (33.2 lbf ft) Loctite®243™
---------------------------	--------	--

- Lift the link fork, mount screw ③ and tighten it.

Guideline

Screw, bottom shock absorber	M10x52	45 Nm (33.2 lbf ft) Loctite®243™
------------------------------	--------	--

- Attach brake line ④ to the holder.

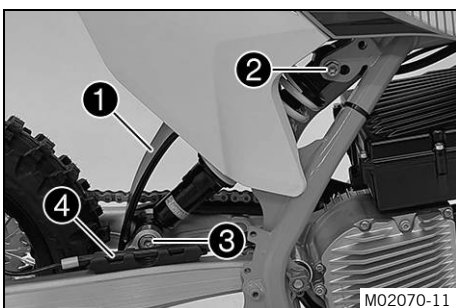

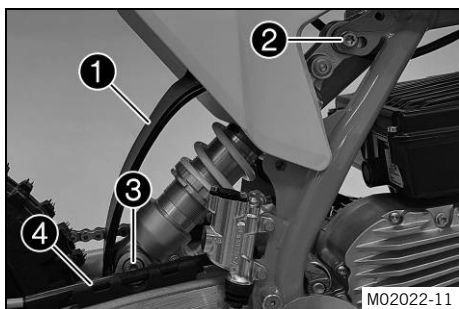

(SX-E 5)

- Push splash protector **1** to the side.
- Mount the shock absorber with screw **2**.

Guideline

If necessary, observe the installation position noted during removal.

Screw, top shock absorber	M10x42	45 Nm (33.2 lbf ft) Loctite®243™
---------------------------	--------	--

- Lift the link fork, mount screw **3** and tighten it.

Guideline

Screw, bottom shock absorber	M10x52	45 Nm (33.2 lbf ft) Loctite®243™
------------------------------	--------	--

- Attach brake line **4** to the holder.

Finishing work

- Remove the motorcycle from the lift stand. (📖 p. 46)

13.20 Checking the rubber buffer and pivot points of the shock absorber (SX-E 3)

Condition

The shock absorber is removed.

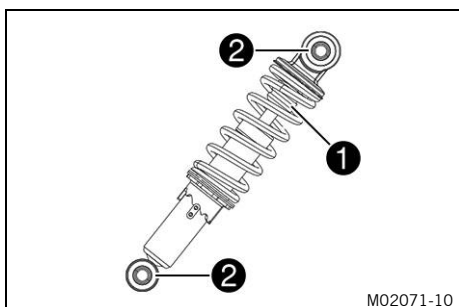

- Check rubber buffer **1** and pivot points **2** of the shock absorber for damage and wear.
 - » If there is damage or wear:
 - Change shock absorber.

13.21 Removing the seat

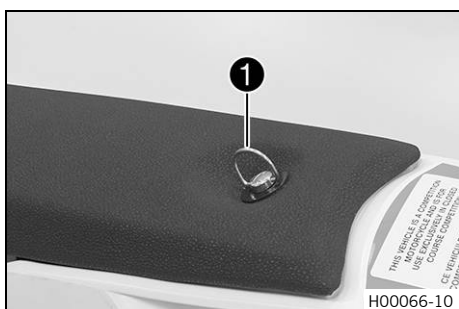

- Open quick release **1** and raise the rear of the seat.
- Pull back the seat and remove it.

13.22 Mounting the seat

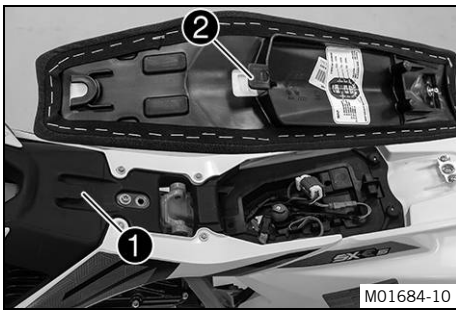

- Hook the seat onto holding lug ①, lower the seat at the rear, and push it forward.
- ✓ Holding lug ② hangs on the front fairing.

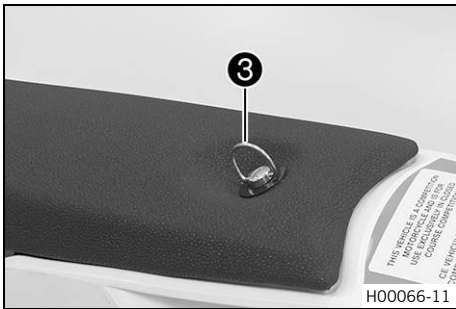

- Close quick release ③.

13.23 Checking the chain for dirt

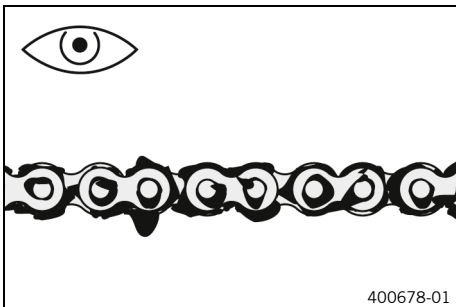

- Check the chain for coarse dirt accumulation.
 - » If the chain is very dirty:
 - Clean the chain. (📖 p. 59)

13.24 Cleaning the chain



Warning

Danger of accidents Lubricants on the tires reduces the road grip.

- Remove lubricants from the tires using a suitable cleaning agent.



Warning

Danger of accidents Oil or grease on the brake discs reduces the braking effect.

- Always keep the brake discs free of oil and grease.
- Clean the brake discs with brake cleaner when necessary.



Note

Environmental hazard Hazardous substances cause environmental damage.

- Dispose of oils, grease, cleaning agents, brake fluid etc. properly and in compliance with the applicable regulations.

i Info

The service life of the chain depends largely on its maintenance.

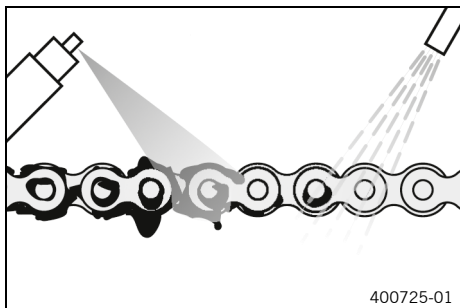

Preparatory work

- Raise the motorcycle with a lift stand. (📖 p. 46)

Main work

- Rinse off the loose dirt with a gentle jet of water.

Guideline

Do not remove the bearing bridge of the engine sprocket.

- Remove old grease residue with chain cleaner.

Chain cleaner (📖 p. 106)

- After drying, apply chain spray.

Off-road chain spray (📖 p. 106)

Finishing work

- Remove the motorcycle from the lift stand. (📖 p. 46)

13.25 Checking the chain tension



Warning

Danger of accidents Incorrect chain tension damages components and results in accidents.

If the chain is tensioned too much, the chain, engine sprocket, rear sprocket, transmission and rear wheel bearings wear more quickly. Some components may break if overloaded.

If the chain is too loose, the chain may fall off the engine sprocket or the rear sprocket. As a result, the rear wheel locks or the engine will be damaged.

- Check the chain tension regularly.
- Set the chain tension in accordance with the specification.

Preparatory work

- Raise the motorcycle with a lift stand. (📖 p. 46)

Main work

- Press the chain upward at the end of the chain sliding piece and determine chain tension **A**.

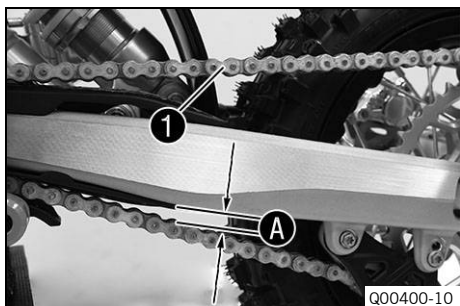

i Info

The top part of chain **1** must be taut.

Chain wear is not always even, so you should repeat this measurement at different chain positions.

Chain tension	5 ... 8 mm (0.2 ... 0.31 in)
---------------	------------------------------

- » If the chain tension does not meet the specification:
 - Adjust the chain tension. (📖 p. 61)

Finishing work

- Remove the motorcycle from the lift stand. (📖 p. 46)

13.26 Adjusting the chain tension



Warning

Danger of accidents Incorrect chain tension damages components and results in accidents.

If the chain is tensioned too much, the chain, engine sprocket, rear sprocket, transmission and rear wheel bearings wear more quickly. Some components may break if overloaded.

If the chain is too loose, the chain may fall off the engine sprocket or the rear sprocket. As a result, the rear wheel locks or the engine will be damaged.

- Check the chain tension regularly.
- Set the chain tension in accordance with the specification.

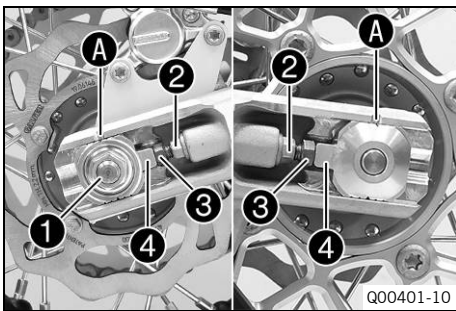

Preparatory work

- Raise the motorcycle with a lift stand. (📖 p. 46)
- Check the chain tension. (📖 p. 60)

Main work

- Loosen nut ①.
- Loosen nuts ②.
- Adjust the chain tension by turning adjusting screws ③ left and right.

Guideline

Chain tension	5 ... 8 mm (0.2 ... 0.31 in)
Turn the adjusting screws ③ on the left and right so that the markings on the left and right chain adjusters ④ are in the same position relative to the reference marks A. The rear wheel is then correctly aligned.	

- Tighten nuts ②.
- Make sure that chain adjusters ④ are fitted correctly on adjusting screws ③.
- Tighten nut ①.

Guideline

Nut, rear wheel spindle	M12x1	40 Nm (29.5 lbf ft)
-------------------------	-------	---------------------

Finishing work

- Remove the motorcycle from the lift stand. (📖 p. 46)



13.27 Checking the chain, rear sprocket, motor sprocket, and chain guide

Preparatory work

- Raise the motorcycle with a lift stand. (📖 p. 46)

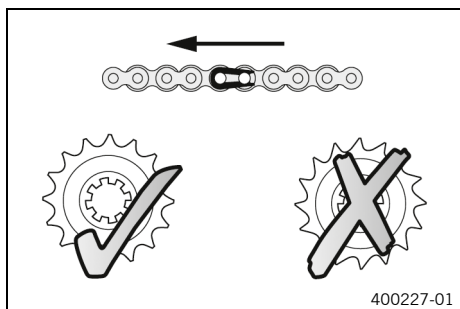

Main work

- Check the chain, rear sprocket, and motor sprocket for wear.
 - » If the chain, rear sprocket or motor sprocket is worn:
 - Change the drivetrain kit. 🛠️



Info

The motor sprocket, rear sprocket, and chain should always be replaced together. When fitting the chain joint, always make sure that the closed side of the joint faces forward (riding direction).

- Check the chain for wear.
 - » If the chain is worn:
 - Change the drivetrain kit. 🛠️



Info

When a new chain is mounted, the rear sprocket and motor sprocket should also be changed. New chains wear out faster on old, worn sprockets.

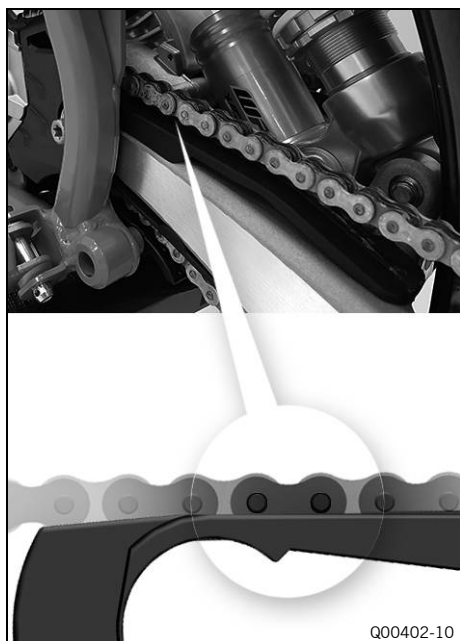

- Check the chain sliding guard for wear.
 - » If the ridge is worn down to the level of the main corpus:
 - Change the chain sliding guard. 🛠️
- Check that the chain sliding guard is firmly seated.
 - » If the chain sliding guard is loose:
 - Tighten the screw of the chain sliding guard.

Guideline

Screw, chain sliding guard	M6	3 Nm (2.2 lbf ft)
----------------------------	----	-------------------

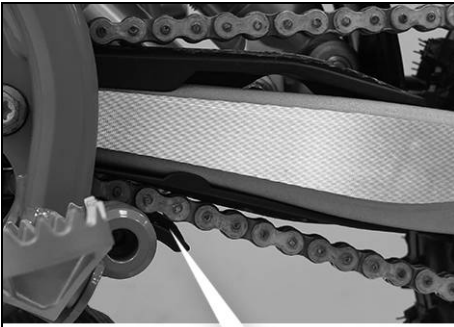

- Check the chain sliding piece for wear.
 - » If the lower edge of the chain pins is in line with or below the chain sliding piece:
 - Change the chain sliding piece. 🛠️
- Check that the chain sliding piece is firmly seated.
 - » If the chain sliding piece is loose:
 - Tighten screw on the chain sliding piece.

Guideline

Screw, chain sliding piece	M8	15 Nm (11.1 lbf ft)
----------------------------	----	------------------------

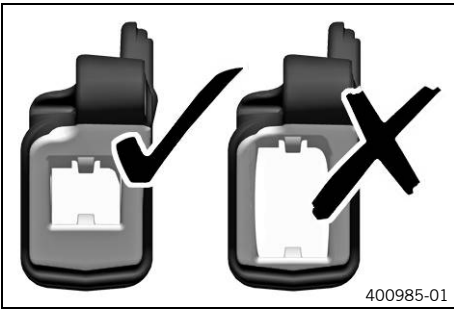

- Check the chain guide for wear.



Info

Wear can be seen on the front of the chain guide.

- » If the light part of the chain guide is worn:
 - Change the chain guide. 🛠️

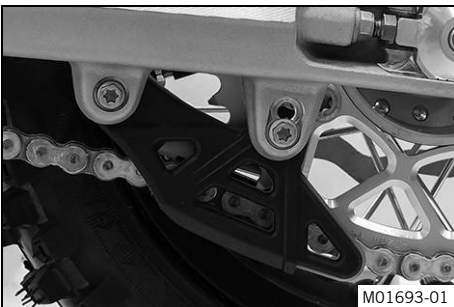

- Check that the chain guide is firmly seated.
 - » If the chain guide is loose:
 - Tighten the screws on the chain guide.

Guideline

Remaining screws, chassis	M6	10 Nm (7.4 lbf ft)
---------------------------	----	-----------------------

Finishing work

- Remove the motorcycle from the lift stand. (📖 p. 46)



13.28 Adjusting the chain guide ↩

i Info

The size of the chain wheel varies with the number of teeth. The chain guide can be adjusted on small sprockets.



- Remove screw ①.
- Position the chain guide.
- Mount and tighten the screw.

Guideline

Remaining screws, chassis	M6	10 Nm (7.4 lbf ft)
---------------------------	----	--------------------

13.29 Checking the frame ↩



- Check the frame for damage, cracks, and deformation.
 - » If the frame shows signs of damage, cracks, or deformation:
 - Change the frame. ↩

Guideline

Repairs on the frame are not permitted.

13.30 Checking the link fork ↩

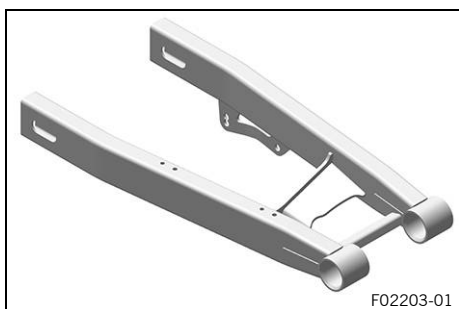

- Check the link fork for damage, cracks, and deformation.
 - » If the link fork shows signs of damage, cracks, or deformation:
 - Change the link fork. ↩

Guideline

Repairs on the link fork are not permitted.

13.31 Checking the rubber grip

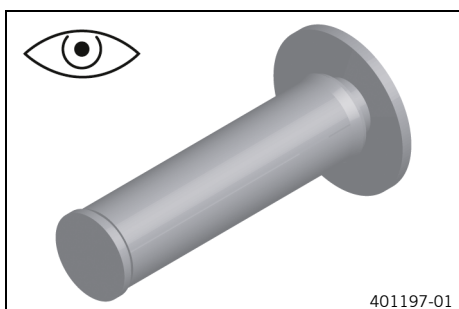

- Check the rubber grips on the handlebar for damage, wear, and looseness.

i Info

The rubber grips are vulcanized onto a sleeve on the left and onto the handle tube of the throttle grip on the right. The left sleeve is clamped onto the handlebar. The rubber grip can only be replaced with the sleeve or the throttle tube.

- » If a rubber grip is damaged or worn:
 - Change the rubber grip.

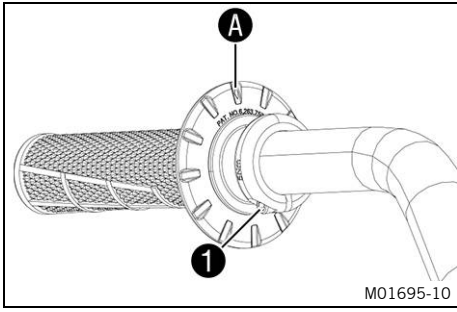

- Check that screw ① is firmly seated.

Guideline

Screw, fixed grip	M4	5 Nm (3.7 lbf ft) Loctite®243™
-------------------	----	--

Diamond ① must be located at the top.



14.1 Checking the play of the front brake lever



Warning

Danger of accidents The brake system fails in the event of overheating.

If there is no free travel on the front brake lever, pressure builds up in the brake system on the front brake.

- Set the free travel on the front brake lever in accordance with the specification.

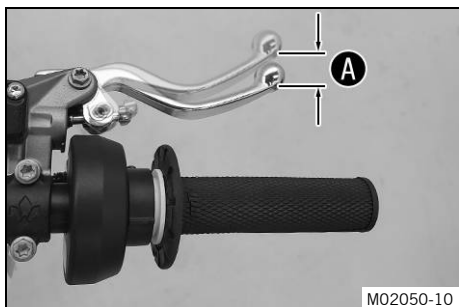

- Push the front brake lever forward and check play **A**.

Play of the front brake lever	3 ... 5 mm (0.12 ... 0.2 in)
-------------------------------	------------------------------

- » If the play does not meet specifications:
 - Inspect the brake system for damage and dirt.

14.2 Adjusting the basic position of the front brake lever

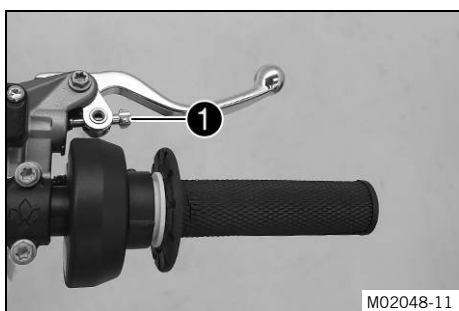

- Adjust the basic position of the front brake lever with adjusting screw **1** to the rider's hand size.



Info

Turn the adjusting screw clockwise to increase the distance between the front brake lever and the handlebar.

Turn the adjusting screw counterclockwise to decrease the distance between the front brake lever and the handlebar.

The range of adjustment is limited.

14.3 Checking the brake discs



Warning

Danger of accidents Worn-out brake discs reduce the braking effect.

- Make sure that worn-out brake discs are replaced immediately. (Your authorized KTM workshop will be glad to help.)

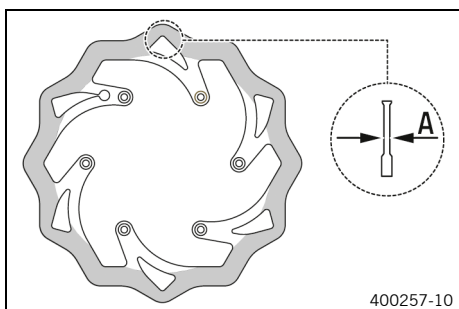

- Check the front and rear brake disc thickness at multiple points for the dimension **A**.



Info

Wear reduces the thickness of the brake disc around the contact surface of the brake linings.

Brake discs - wear limits	
front	2.2 mm (0.087 in)
rear	2.2 mm (0.087 in)

- » If the brake disc thickness is less than the specified value:

- Change the front brake disc. 🛠️
- Change the rear brake disc. 🛠️
- Check the front and rear brake discs for damage, cracking, and deformation.
 - » If the brake disc exhibits damage, cracking, or deformation:
 - Change the front brake disc. 🛠️
 - Change the rear brake disc. 🛠️



14.4 Checking the front brake fluid level



Warning

Danger of accidents An insufficient brake fluid level will cause the brake system to fail.

If the brake fluid level drops below the specified marking or the specified value, the brake system is leaking or the brake linings are worn down.

- Check the brake system and do not continue riding until the problem is eliminated. (Your authorized KTM workshop will be glad to help.)



Warning

Skin irritation Brake fluid is a harmful substance.

- Keep brake fluid out of the reach of children.
- Wear suitable protective clothing and safety glasses.
- Do not allow brake fluid to come into contact with the skin, the eyes or clothing.
- Consult a doctor immediately if brake fluid has been swallowed.
- Rinse the affected area with plenty of water in the event of contact with the skin.
- Rinse eyes thoroughly with water immediately and consult a doctor if brake fluid comes into contact with the eyes.
- If brake fluid spills on to your clothing, change the clothing.



Warning

Danger of accidents Brake fluid which is too old or of the wrong type impairs the function of the brake system.

- Make sure that brake fluid for the front and rear brake is changed in accordance with the service schedule. (Your authorized KTM workshop will be glad to help.)
- Make sure that only clean, approved brake fluid from a tightly sealed container is used. (Your authorized KTM workshop will be glad to help.)



Note

Environmental hazard Hazardous substances cause environmental damage.

- Dispose of oils, grease, cleaning agents, brake fluid etc. properly and in compliance with the applicable regulations.



Info

Avoid contact between brake fluid and painted parts. Brake fluid corrodes paint.

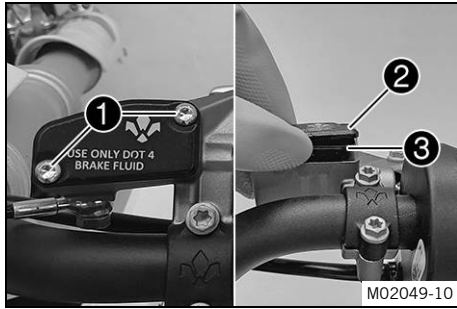

- Move the brake fluid reservoir mounted on the handlebar to a horizontal position.
- Remove screws **1**.
- Take off cover **2** with membrane **3**.
- Check the brake fluid level.

Brake fluid level below reservoir rim	4 mm (0.16 in)
---------------------------------------	----------------

- » If the brake fluid level does not meet specifications:
 - Add front brake fluid. (p. 68)
- Position the cover with the membrane. Mount and tighten the screws.



Info

Use water to immediately clean up any brake fluid that has overflowed or spilled.

14.5 Adding front brake fluid



Warning

Danger of accidents An insufficient brake fluid level will cause the brake system to fail.

If the brake fluid level drops below the specified marking or the specified value, the brake system is leaking or the brake linings are worn down.

- Check the brake system and do not continue riding until the problem is eliminated. (Your authorized KTM workshop will be glad to help.)



Warning

Skin irritation Brake fluid is a harmful substance.

- Keep brake fluid out of the reach of children.
- Wear suitable protective clothing and safety glasses.
- Do not allow brake fluid to come into contact with the skin, the eyes or clothing.
- Consult a doctor immediately if brake fluid has been swallowed.
- Rinse the affected area with plenty of water in the event of contact with the skin.
- Rinse eyes thoroughly with water immediately and consult a doctor if brake fluid comes into contact with the eyes.
- If brake fluid spills on to your clothing, change the clothing.



Warning

Danger of accidents Brake fluid which is too old or of the wrong type impairs the function of the brake system.

- Make sure that brake fluid for the front and rear brake is changed in accordance with the service schedule. (Your authorized KTM workshop will be glad to help.)
- Make sure that only clean, approved brake fluid from a tightly sealed container is used. (Your authorized KTM workshop will be glad to help.)



Note

Environmental hazard Hazardous substances cause environmental damage.

- Dispose of oils, grease, cleaning agents, brake fluid etc. properly and in compliance with the applicable regulations.

i Info

Avoid contact between brake fluid and painted parts. Brake fluid corrodes paint.

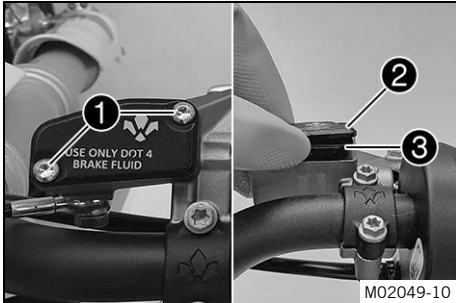

Preparatory work

- Check that the brake linings of the front brake are secured. (📖 p. 69)

Main work

- Move the brake fluid reservoir mounted on the handlebar to a horizontal position.
- Remove screws **1**.
- Take off cover **2** with membrane **3**.
- Correct the brake fluid level.

Guideline

Brake fluid level below reservoir rim	4 mm (0.16 in)
---------------------------------------	----------------

Brake fluid DOT 4 / DOT 5.1 (📖 p. 105)	
--	--

- Position the cover with the membrane. Mount and tighten the screws.

i Info

Use water to immediately clean up any brake fluid that has overflowed or spilled.



14.6 Checking that the brake linings of the front brake are secured



Warning

Danger of accidents Worn-out brake linings reduce the braking effect.

- Ensure that worn-out brake linings are replaced immediately. (Your authorized KTM workshop will be glad to help.)

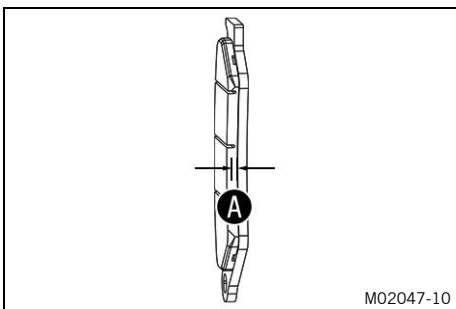

- Check the brake linings for lining thickness **A**.

Minimum thickness A	$\geq 1 \text{ mm } (\geq 0.04 \text{ in})$
----------------------------	---

- » If it is less than the minimum thickness:
 - Change the brake linings of the front brake. (📖 p. 70)
- Check the brake linings for damage and cracking.
 - » If there is damage or cracking:
 - Change the brake linings of the front brake. (📖 p. 70)
- Check that the brake linings are secured.
 - » If the brake linings are not secured correctly:
 - Secure brake linings, replace with new parts if necessary.



14.7 Changing the brake linings of the front brake ↩



Warning

Danger of accidents Incorrect servicing will cause the brake system to fail.

- Ensure that service work and repairs are performed professionally. (Your authorized KTM workshop will be glad to help.)



Warning

Skin irritation Brake fluid is a harmful substance.

- Keep brake fluid out of the reach of children.
- Wear suitable protective clothing and safety glasses.
- Do not allow brake fluid to come into contact with the skin, the eyes or clothing.
- Consult a doctor immediately if brake fluid has been swallowed.
- Rinse the affected area with plenty of water in the event of contact with the skin.
- Rinse eyes thoroughly with water immediately and consult a doctor if brake fluid comes into contact with the eyes.
- If brake fluid spills on to your clothing, change the clothing.



Warning

Danger of accidents Brake fluid which is too old or of the wrong type impairs the function of the brake system.

- Make sure that brake fluid for the front and rear brake is changed in accordance with the service schedule. (Your authorized KTM workshop will be glad to help.)
- Make sure that only clean, approved brake fluid from a tightly sealed container is used. (Your authorized KTM workshop will be glad to help.)



Warning

Danger of accidents Brake linings which have not been approved alter the braking efficiency.

Not all brake linings are tested and approved for KTM motorcycles. The structure and friction coefficient of the brake linings, and thus their brake power, may vary greatly from that of original brake linings.

If brake linings are used that differ from the original equipment, compliance with the original homologation is not guaranteed. In this case, the vehicle no longer corresponds to its condition at delivery and the manufacturer warranty shall be void.

- Only use brake linings approved and recommended by KTM.



Note

Environmental hazard Hazardous substances cause environmental damage.

- Dispose of oils, grease, cleaning agents, brake fluid etc. properly and in compliance with the applicable regulations.



Info

Avoid contact between brake fluid and painted parts. Brake fluid corrodes paint.

Preparatory work

- Raise the motorcycle with a lift stand. (🔧 p. 46)

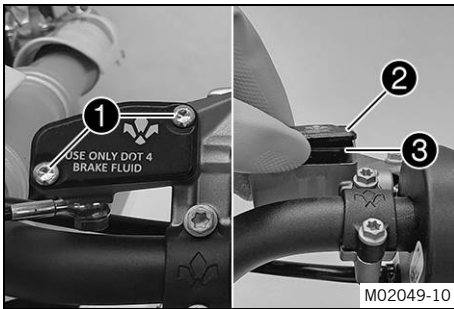

M02049-10

Main work

- Move the brake fluid reservoir mounted on the handlebar to a horizontal position.
- Remove screws ①.
- Take off cover ② with membrane ③.

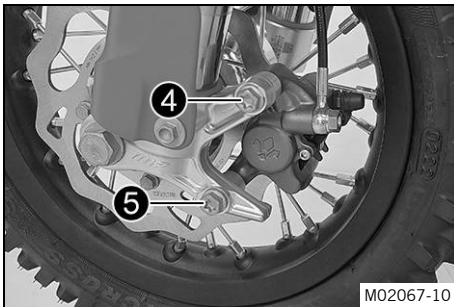

M02067-10

- Remove screw ④ and ⑤.
- Press back the brake linings by slightly tilting the brake caliper laterally on the brake disc. Carefully pull the brake caliper backward from the brake disc.
- Press the brake piston back into the basic position and ensure that brake fluid does not flow out of the brake fluid reservoir; extract some if necessary.

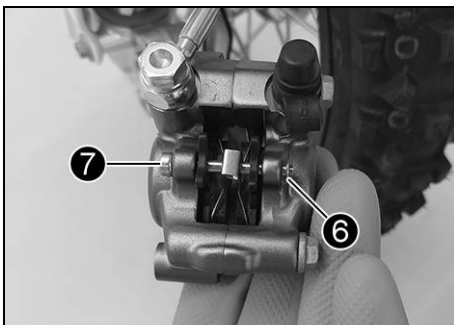

- Remove lock ring ⑥.
- Remove screw ⑦.
- Remove the brake linings.
- Clean the brake caliper and the brake caliper bracket.
- Position the new brake linings.



Info

Always change the brake linings in pairs.
Ensure that the brake linings are correctly positioned in the holding spring.

- Mount and tighten screw ⑦.

Guideline

Screw, brake linings	M5	8 Nm (5.9 lbf ft)
----------------------	----	-------------------

- Mount lock ring ⑥.



Warning

Danger of accidents Oil or grease on the brake discs reduces the braking effect.

- Always keep the brake discs free of oil and grease.
- Clean the brake discs with brake cleaner when necessary.



M02059-10

- Check the brake discs. (📖 p. 66)

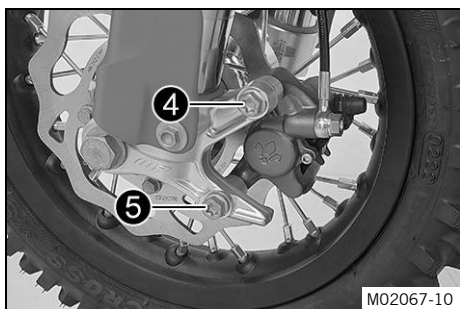

- Position the brake caliper, mount screw ④, and tighten.

Guideline

Screw, front brake caliper	M8x35	20 Nm (14.8 lbf ft) Loctite®243™
----------------------------	-------	--

- Mount and tighten screw ⑤.

Guideline

Screw, front brake caliper	M8x35	20 Nm (14.8 lbf ft) Loctite®243™
----------------------------	-------	--

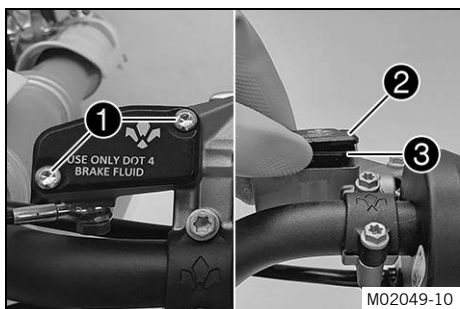

- Check the brake fluid level and correct if necessary.

Guideline

Brake fluid level below reservoir rim	4 mm (0.16 in)
---------------------------------------	----------------

Brake fluid DOT 4 / DOT 5.1 (📖 p. 105)
--

- Position cover ② with membrane ③.
- Mount and tighten screws ①.



Info

Use water to immediately clean up any brake fluid that has overflowed or spilled.

Finishing work

- Remove the motorcycle from the lift stand. (📖 p. 46)

14.8 Checking the free travel of the rear brake lever



Warning

Danger of accidents The brake system fails in the event of overheating.

If there is no free travel on the rear brake lever, pressure builds up in the brake system on the rear brake.

- Set the free travel on the rear brake lever in accordance with the specification.

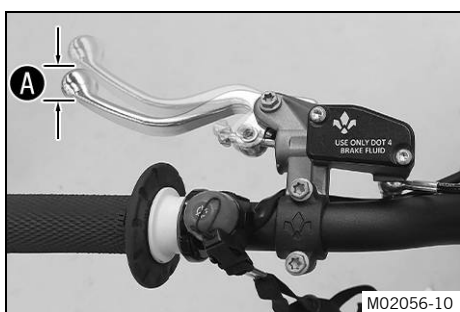

(SX-E 3)

- Push the rear brake lever forward and check play ①.

Play of the rear brake lever	3 ... 5 mm (0.12 ... 0.2 in)
------------------------------	------------------------------

- » If the play does not meet specifications:
 - Inspect the brake system for damage and dirt.

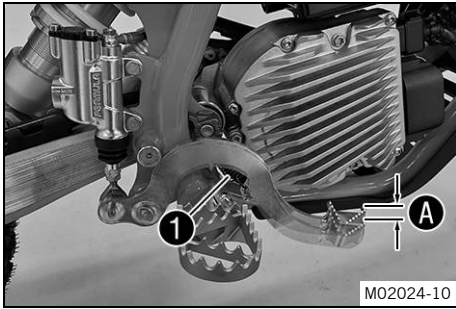

(SX-E 5)

- Detach spring ①.
- Move the foot brake lever back and forth between the end stop and the contact to the rear brake cylinder piston and check free travel A.

Guideline

Free travel of foot brake lever	3 ... 5 mm (0.12 ... 0.2 in)
---------------------------------	------------------------------

- » If the free travel does not match the specification:
 - Adjust the free travel of the hand brake lever. ↩ (📖 p. 73)
- Attach spring ①.



14.9 Adjusting the free travel of the foot brake lever ↩ (SX-E 5)



Warning

Danger of accidents The brake system will fail if it overheats or is adjusted incorrectly.

If there is no free travel on the foot brake lever, pressure builds up in the brake system on the rear brake.

- Set the free travel on the foot brake lever in accordance with the specification.
- Ensure that the adjustment steps are performed properly. (Your authorized KTM workshop will be glad to help.)

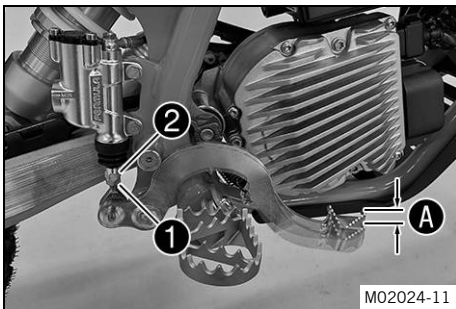

- Detach the foot brake lever spring.
- Loosen nut ①.
- Turn push rod ② accordingly until you have free travel A.

Guideline

Free travel of foot brake lever	3 ... 5 mm (0.12 ... 0.2 in)
---------------------------------	------------------------------

- Hold push rod ② and tighten nut ①.
- Attach the foot brake lever spring.
- Check whether the basic position of the foot brake lever is suitable for the rider.
 - » When the basic position of the foot brake lever needs to be adjusted:
 - Adjust the basic position of the rear brake lever. ↩ (📖 p. 73)



14.10 Adjusting the basic position of the rear brake lever ↩



Warning

Danger of accidents The brake system fails in the event of overheating.

If there is no free travel on the rear brake lever, pressure builds up in the brake system on the rear brake.

- Set the free travel on the rear brake lever in accordance with the specification.

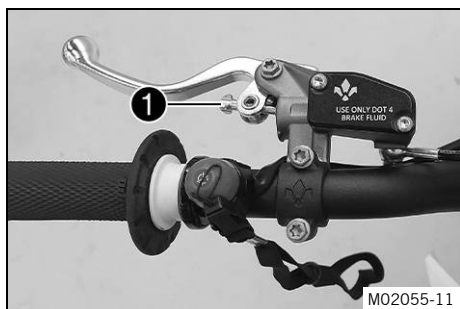

(SX-E 3)

- Adjust the basic position of the rear brake lever with adjusting screw 1 to the rider's hand size.



Info

Turn the adjusting screw clockwise to increase the distance between the rear brake lever and the handlebar.

Turn the adjusting screw counterclockwise to decrease the distance between the rear brake lever and the handlebar.

The range of adjustment is limited.

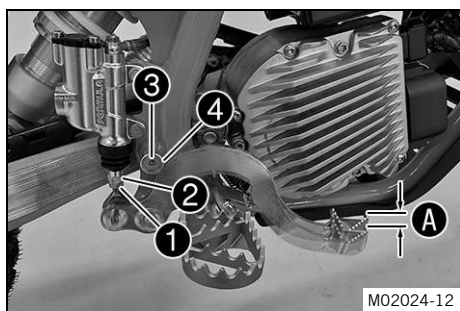

(SX-E 5)

- Detach the foot brake lever spring.
- Loosen nut 1.
- Turn back push rod 2 until free travel is at a maximum.
- For an individual adjustment of the basic position of the foot brake lever, loosen the screw 3 and turn the eccentric brake lever stop 4 accordingly.
- Tighten screw 3.

Guideline

Remaining screws, chassis	M6	10 Nm (7.4 lbf ft)
---------------------------	----	--------------------

- Turn push rod 2 accordingly until you have free travel A.

Guideline

Free travel of foot brake lever	3 ... 5 mm (0.12 ... 0.2 in)
---------------------------------	------------------------------

- Hold push rod 2 and tighten nut 1.
- Attach the foot brake lever spring.
- Check whether the basic position of the foot brake lever is suitable for the rider.

14.11 Checking the rear brake fluid level



Warning

Danger of accidents An insufficient brake fluid level will cause the brake system to fail.

If the brake fluid level drops below the specified marking or the specified value, the brake system is leaking or the brake linings are worn down.

- Check the brake system and ensure that nobody drives the vehicle before the problem is eliminated. (Your authorized KTM workshop will be glad to help.)



Warning

Danger of accidents Brake fluid which is too old or of the wrong type impairs the function of the brake system.

- Make sure that brake fluid for the front and rear brake is changed in accordance with the service schedule. (Your authorized KTM workshop will be glad to help.)
- Make sure that only clean, approved brake fluid from a tightly sealed container is used. (Your authorized KTM workshop will be glad to help.)

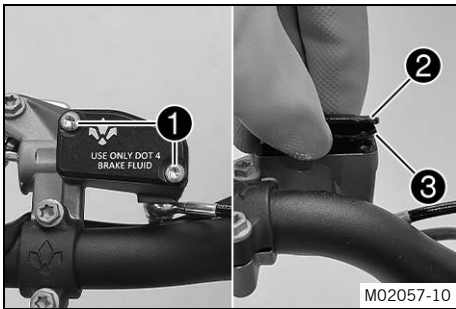

(SX-E 3)

- Move the brake fluid reservoir mounted on the handlebar to a horizontal position.
- Remove screws ①.
- Take off cover ② with membrane ③.
- Check the brake fluid level.

Brake fluid level below reservoir rim	4 mm (0.16 in)
---------------------------------------	----------------

- » If the brake fluid level does not meet specifications:
 - Add rear brake fluid. 🛠️ (📖 p. 75)
- Position the cover with the membrane. Mount and tighten the screws.



Info

Use water to immediately clean up any brake fluid that has overflowed or spilled.

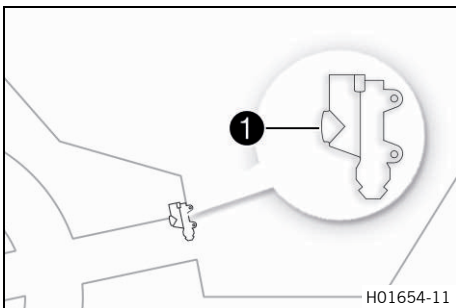

(SX-E 5)

- Stand the vehicle upright.
- Check the brake fluid level in level viewer ①.
 - » If the brake fluid level is below the **MIN** marking:
 - Add rear brake fluid. 🛠️ (📖 p. 75)

14.12 Adding rear brake fluid 🛠️



Warning

Danger of accidents An insufficient brake fluid level will cause the brake system to fail.

If the brake fluid level drops below the specified marking or the specified value, the brake system is leaking or the brake linings are worn down.

- Check the brake system and ensure that nobody drives the vehicle before the problem is eliminated. (Your authorized KTM workshop will be glad to help.)



Warning

Skin irritation Brake fluid is a harmful substance.

- Keep brake fluid out of the reach of children.
- Wear suitable protective clothing and safety glasses.
- Do not allow brake fluid to come into contact with the skin, the eyes or clothing.
- Consult a doctor immediately if brake fluid has been swallowed.
- Rinse the affected area with plenty of water in the event of contact with the skin.
- Rinse eyes thoroughly with water immediately and consult a doctor if brake fluid comes into contact with the eyes.
- If brake fluid spills on to your clothing, change the clothing.



Warning

Danger of accidents Brake fluid which is too old or of the wrong type impairs the function of the brake system.

- Make sure that brake fluid for the front and rear brake is changed in accordance with the service schedule. (Your authorized KTM workshop will be glad to help.)
- Make sure that only clean, approved brake fluid from a tightly sealed container is used. (Your authorized KTM workshop will be glad to help.)



Note

Environmental hazard Hazardous substances cause environmental damage.

- Dispose of oils, grease, cleaning agents, brake fluid etc. properly and in compliance with the applicable regulations.



Info

Avoid contact between brake fluid and painted parts. Brake fluid corrodes paint.

Preparatory work

- Raise the motorcycle with a lift stand. (📖 p. 46)
- Check that the brake linings of the rear brake are secured. (📖 p. 77)

Main work (SX-E 3)

- Remove screws **1**.
- Take off cover **2** with membrane **3**.
- Correct the brake fluid level.

Guideline

Brake fluid level below reservoir rim	4 mm (0.16 in)
---------------------------------------	----------------

Brake fluid DOT 4 / DOT 5.1 (📖 p. 105)
--

- Position the cover with the membrane.
- Mount and tighten the screws.



Info

Use water to immediately clean up any brake fluid that has overflowed or spilled.

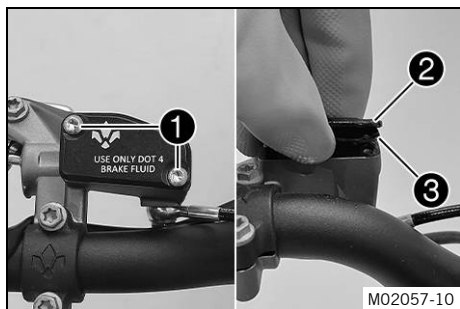

(SX-E 5)

- Remove screws **1**.
- Take off cover **2** with membrane **3**.

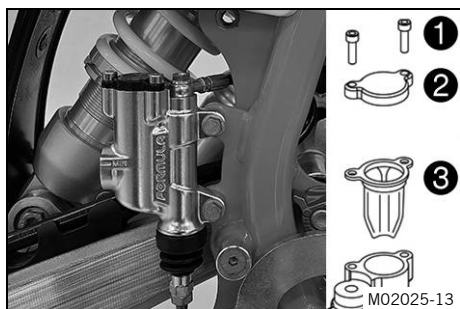

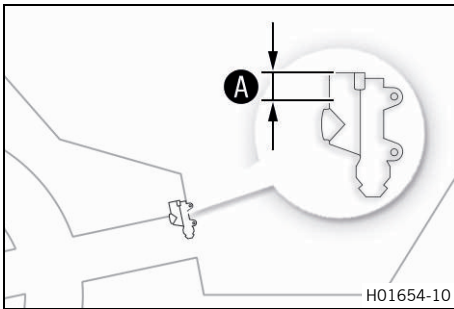

- Add brake fluid up to level **A**.

Guideline

Level A (brake fluid level below reservoir rim)	10 mm (0.39 in)
--	-----------------

Brake fluid DOT 4 / DOT 5.1 (📖 p. 105)
--

- Position the cover with the membrane.
- Mount and tighten the screws.

i Info
Use water to immediately clean up any brake fluid that has overflowed or spilled.

Finishing work

- Remove the motorcycle from the lift stand. (📖 p. 46)



14.13 Checking the brake linings and the brake lining retainers of the rear brake



Warning

Danger of accidents Worn-out brake linings reduce the braking effect.

- Ensure that worn-out brake linings are replaced immediately. (Your authorized KTM workshop will be glad to help.)

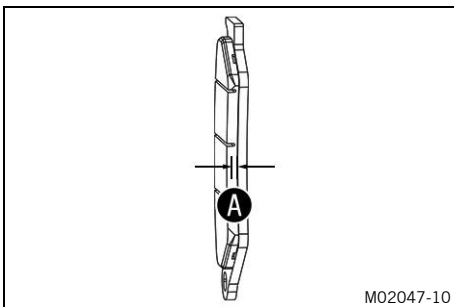

- Check the brake linings for lining thickness **A**.

Minimum thickness A	$\geq 1 \text{ mm } (\geq 0.04 \text{ in})$
----------------------------	---

- » If the minimum thickness is less than specified:
 - Change the rear brake linings. 🛠️ (📖 p. 77)
- Check the brake linings for damage and cracking.
 - » If damage or wear is encountered:
 - Change the rear brake linings. 🛠️ (📖 p. 77)
- Check that the brake linings are secured.
 - » If the brake linings are not secured correctly:
 - Secure brake linings, replace with new parts if necessary.



14.14 Changing the rear brake linings 🛠️



Warning

Danger of accidents Incorrect servicing will cause the brake system to fail.

- Ensure that service work and repairs are performed professionally. (Your authorized KTM workshop will be glad to help.)



Warning

Skin irritation Brake fluid is a harmful substance.

- Keep brake fluid out of the reach of children.
- Wear suitable protective clothing and safety glasses.
- Do not allow brake fluid to come into contact with the skin, the eyes or clothing.
- Consult a doctor immediately if brake fluid has been swallowed.
- Rinse the affected area with plenty of water in the event of contact with the skin.
- Rinse eyes thoroughly with water immediately and consult a doctor if brake fluid comes into contact with the eyes.
- If brake fluid spills on to your clothing, change the clothing.



Warning

Danger of accidents Brake fluid which is too old or of the wrong type impairs the function of the brake system.

- Make sure that brake fluid for the front and rear brake is changed in accordance with the service schedule. (Your authorized KTM workshop will be glad to help.)
- Make sure that only clean, approved brake fluid from a tightly sealed container is used. (Your authorized KTM workshop will be glad to help.)



Warning

Danger of accidents Oil or grease on the brake discs reduces the braking effect.

- Always keep the brake discs free of oil and grease.
- Clean the brake discs with brake cleaner when necessary.



Warning

Danger of accidents Brake linings which have not been approved alter the braking efficiency.

Not all brake linings are tested and approved for KTM motorcycles. The structure and friction coefficient of the brake linings, and thus their brake power, may vary greatly from that of original brake linings.

If brake linings are used that differ from the original equipment, compliance with the original homologation is not guaranteed. In this case, the vehicle no longer corresponds to its condition at delivery and the manufacturer warranty shall be void.

- Only use brake linings approved and recommended by KTM.



Note

Environmental hazard Hazardous substances cause environmental damage.

- Dispose of oils, grease, cleaning agents, brake fluid etc. properly and in compliance with the applicable regulations.



Info

Avoid contact between brake fluid and painted parts. Brake fluid corrodes paint.

Preparatory work

- Raise the motorcycle with a lift stand. (🔧 p. 46)

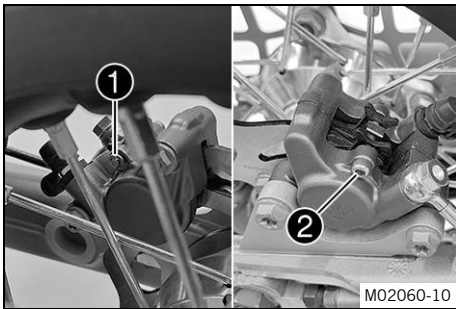

Main work (SX-E 3)

- Remove lock ring ①.
- Remove screw ②.



- Remove the brake linings.
- Clean the brake caliper and the brake caliper bracket.

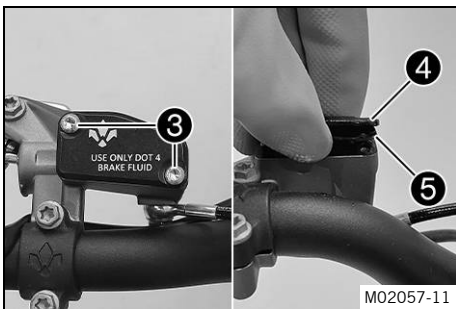

- Remove screws ③.
- Take off cover ④ with membrane ⑤.
- Press the brake piston back into the basic position and ensure that brake fluid does not flow out of the brake fluid reservoir; extract some if necessary.

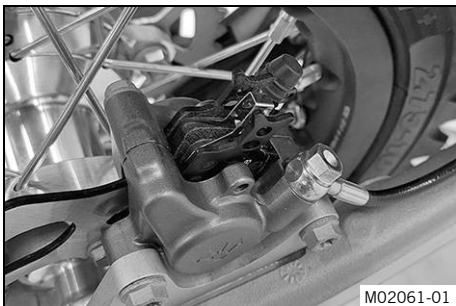

- Position the new brake linings.



Info

Always change the brake linings in pairs.
Ensure that the brake linings are correctly positioned in the holding spring.

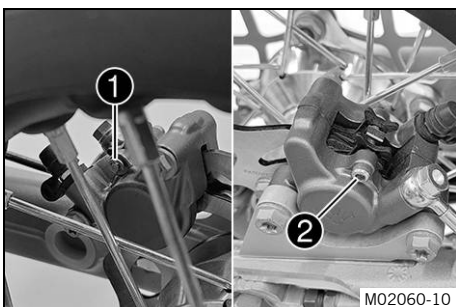

- Mount and tighten screw ②.

Guideline

Screw, brake linings	M5	8 Nm (5.9 lbf ft)
----------------------	----	-------------------

- Mount lock ring ①.

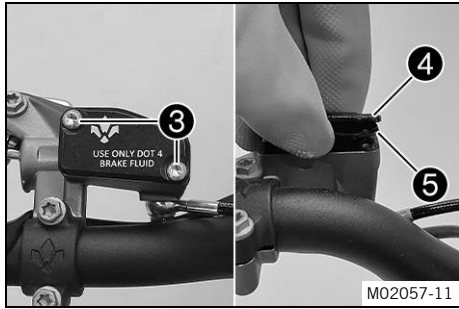

- Operate the rear brake lever several times until the brake linings are in contact with the brake disc and there is a pressure point.
- Check the brake fluid level and correct if necessary.

Guideline

Brake fluid level below reservoir rim	4 mm (0.16 in)
---------------------------------------	----------------

Brake fluid DOT 4 / DOT 5.1 (p. 105)

- Position cover (4) with membrane (5).
- Mount and tighten screws (3).

i Info Use water to immediately clean up any brake fluid that has overflowed or spilled.

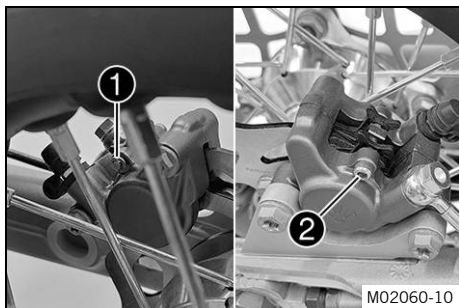

(SX-E 5)

- Remove lock ring (1).
- Remove screw (2).

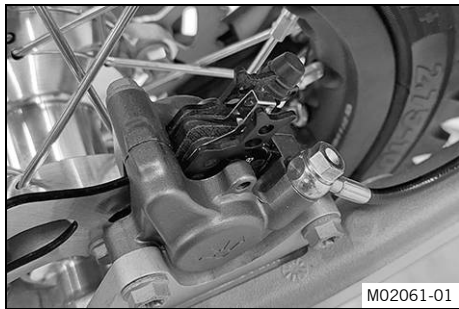

- Remove the brake linings.
- Clean the brake caliper and the brake caliper bracket.

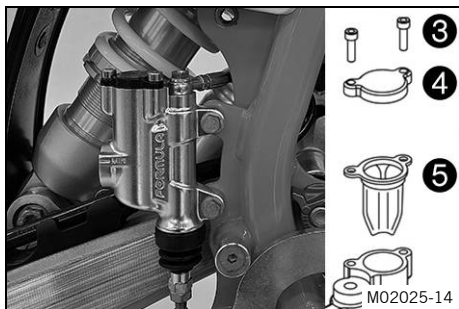

- Remove screws (3).
- Take off cover (4) with membrane (5).
- Press the brake piston back into the basic position and ensure that brake fluid does not flow out of the brake fluid reservoir; extract some if necessary.

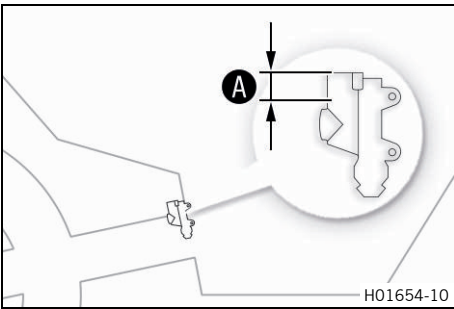
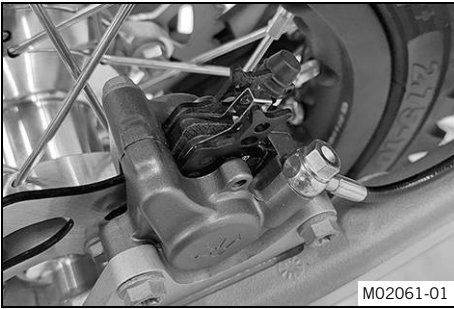

- Position the new brake linings.

i Info
Always change the brake linings in pairs.
Ensure that the brake linings are correctly positioned in the holding spring.

- Operate the foot brake lever repeatedly until the brake linings are in contact with the brake disc and there is a pressure point.
- Add brake fluid up to level **A**.

Guideline

Level A (brake fluid level below reservoir rim)	10 mm (0.39 in)
--	-----------------

Brake fluid DOT 4 / DOT 5.1 (📖 p. 105)
--

- Position the cover with the membrane.
- Mount and tighten the screws.

i Info
Use water to immediately clean up any brake fluid that has overflowed or spilled.

Finishing work

- Remove the motorcycle from the lift stand. (📖 p. 46)



15.1 Removing the front wheel ↴

Preparatory work

- Raise the motorcycle with a lift stand. (📖 p. 46)

Main work

- Remove screw ①.
- Loosen screws ②.

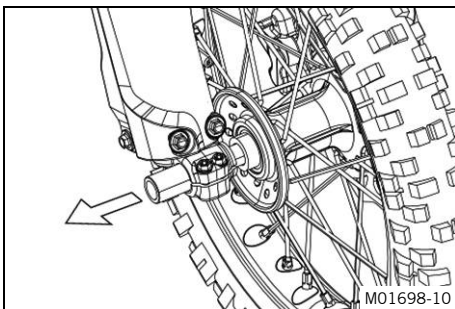
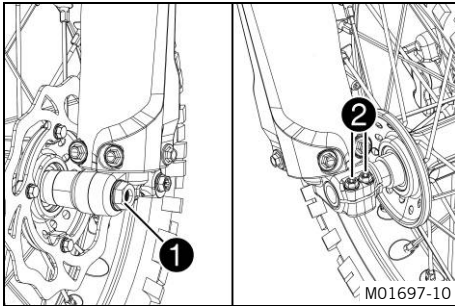

Warning

Danger of accidents Damaged brake discs reduce the braking effect.

- Always lay the wheel down in such a way that the brake disc is not damaged.

- Hold the front wheel and remove the wheel spindle. Take the front wheel out of the fork.



Info

Do not actuate the hand brake lever when the front wheel is removed.

- Remove spacers ③.

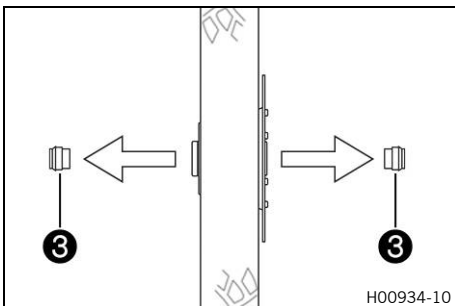

15.2 Installing the front wheel ↴



Warning

Danger of accidents Oil or grease on the brake discs reduces the braking effect.

- Always keep the brake discs free of oil and grease.
- Clean the brake discs with brake cleaner when necessary.

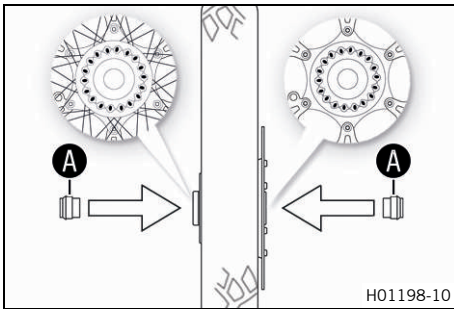

- Check the wheel bearing for damage and wear.
 - » If the wheel bearing is damaged or worn:
 - Change front wheel bearing. 🛠️
- Clean and grease the contact surfaces **A** of the spacers.

Long-life grease (📖 p. 106)

- Insert the spacers.

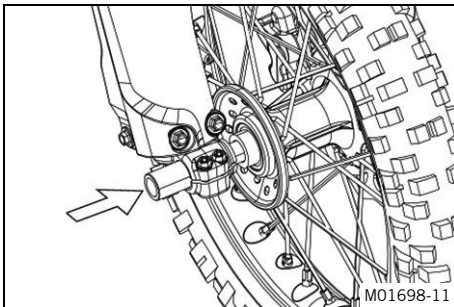

- Clean and grease the wheel spindle.

Long-life grease (📖 p. 106)

- Position the front wheel.
 - ✓ The brake linings are correctly positioned.
- Insert the wheel spindle.

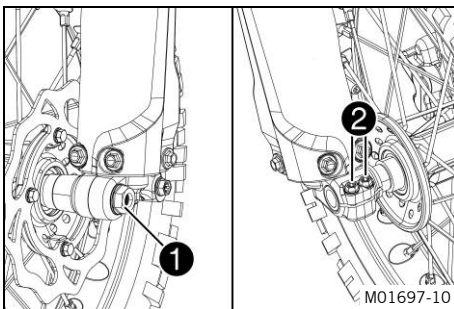

- Mount and tighten screw **1**.

Guideline

Screw, front wheel spindle	M10	40 Nm (29.5 lbf ft) Loctite®243™
----------------------------	-----	--

- Operate the hand brake lever several times until the brake linings are seated correctly against the brake disc.
- Remove the motorcycle from the lift stand. (📖 p. 46)
- Operate the front brake and compress the fork a few times firmly.

✓ The fork legs straighten.

- Tighten screws **2**.

Guideline

Screw, fork stub	M6	10 Nm (7.4 lbf ft)
------------------	----	--------------------

15.3 Removing the rear wheel 🛠️

Preparatory work

- Raise the motorcycle with a lift stand. (📖 p. 46)

Main work

- Remove nut **1**.
- Take off chain adjuster **2**.

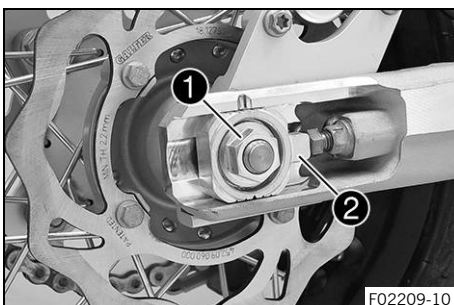

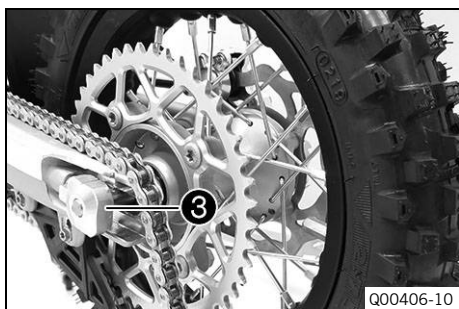

- Pull out wheel spindle **3** far enough to allow the rear wheel to be pushed forward.
- Push the rear wheel forward as far as possible. Remove the chain from the rear sprocket.

Info
Cover the components to protect them against damage.

Warning
Danger of accidents Damaged brake discs reduce the braking effect.

- Always lay the wheel down in such a way that the brake disc is not damaged.

- Hold the rear wheel and remove the wheel spindle. Take the rear wheel out of the link fork.

Info
Do not operate the foot brake lever when the rear wheel is removed.

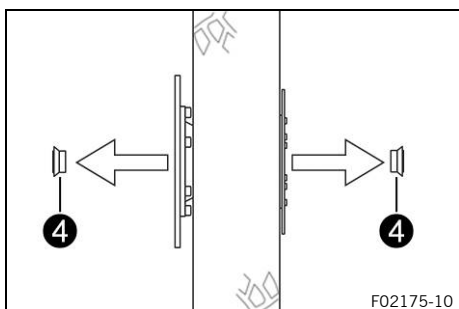

- Remove spacers **4**.

15.4 Installing the rear wheel

Warning
Danger of accidents Oil or grease on the brake discs reduces the braking effect.

- Always keep the brake discs free of oil and grease.
- Clean the brake discs with brake cleaner when necessary.

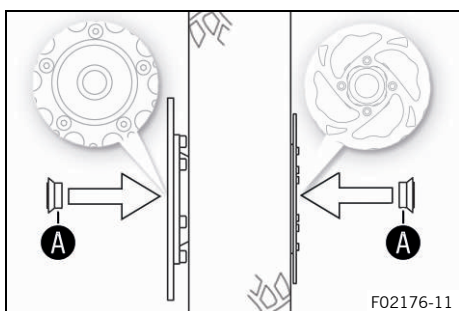

Main work

- Check the wheel bearing for damage and wear.
 - » If the wheel bearing is damaged or worn:
 - Change the rear wheel bearing.
- Clean and grease the contact surfaces **A** of the spacers.

Long-life grease (p. 106)

- Insert the spacers.

Info
Insert the wide spacer on the left in the direction of travel.



- Clean and grease wheel spindle ①.

Long-life grease (📖 p. 106)

- Position the rear wheel and insert wheel spindle.
 - ✓ The brake linings are correctly positioned.
- Mount the chain.
- Position chain adjuster ② on both sides and push the wheel spindle in all the way.

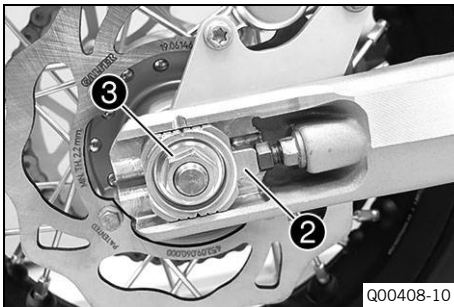

- Mount nut ③, but do not tighten it yet.
- Make sure that the chain adjusters are fitted correctly on the adjusting screws.
- Check the chain tension. (📖 p. 60)
- Tighten nut ③.

Guideline

Nut, rear wheel spindle	M12x1	40 Nm (29.5 lbf ft)
-------------------------	-------	---------------------

- Operate the foot brake lever repeatedly until the brake linings are in contact with the brake disc and there is a pressure point.

Finishing work

- Remove the motorcycle from the lift stand. (📖 p. 46)



15.5 Checking the tire condition



Info

Only mount tires approved and/or recommended by KTM.

Other tires could have a negative effect on handling characteristics.

The type, condition, and pressure of the tires all have a major impact on the handling characteristic of the motorcycle.

The tires mounted on the front and rear wheels must have a similar profile.

Worn tires have a negative effect on handling characteristics, especially on wet surfaces.

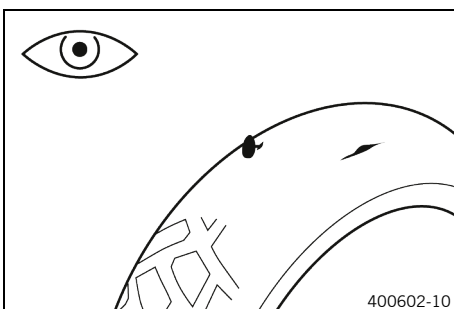

- Check the front and rear tires for cuts, embedded objects, and other damage.
 - » If the tires have cuts, run-in objects, or other damage:
 - Change the tires. 🛠️

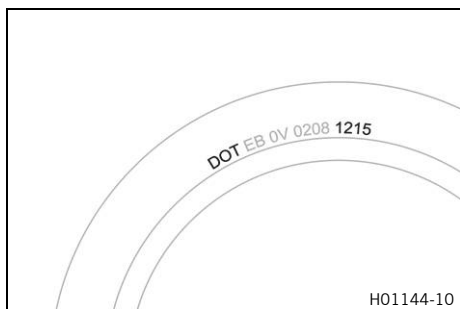

- Check the tire age.



Info

The tire date of manufacture is usually contained in the tire label and is indicated by the last four digits of the **DOT** number. The first two digits indicate the week of manufacture and the last two digits the year of manufacture.

KTM recommends that the tires be changed after 5 years at the latest, regardless of the actual state of wear.

- » If the tires are more than five years old:
 - Change the tires. 🛠️

15.6 Checking tire pressure



Info

Low tire pressure leads to abnormal wear and overheating of the tire.

Correct tire pressure ensures optimal riding comfort and maximum tire service life.

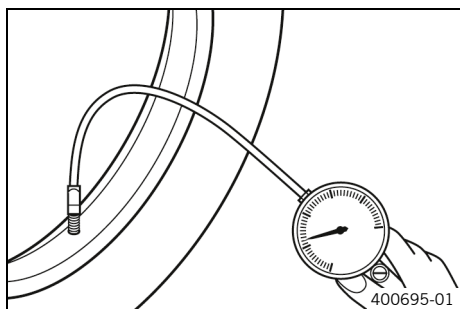

- Remove protection cap.
- Check tire pressure when the tires are cold.

Offroad tire pressure	
front	1.0 bar (15 psi)
rear	1.0 bar (15 psi)

- » If the tire pressure does not meet specifications:
 - Correct tire pressure.
- Mount the protection cap.

15.7 Checking the spoke tension



Warning

Danger of accidents Incorrectly tensioned spokes impair the handling characteristic and result in secondary damage.

The spokes break due to being overloaded if they are too tightly tensioned. If the tension in the spokes is too low, then lateral and radial run-out will form in the wheel. Other spokes will become looser as a result.

- Check spoke tension regularly, and in particular on a new vehicle. (Your authorized KTM workshop will be glad to help.)

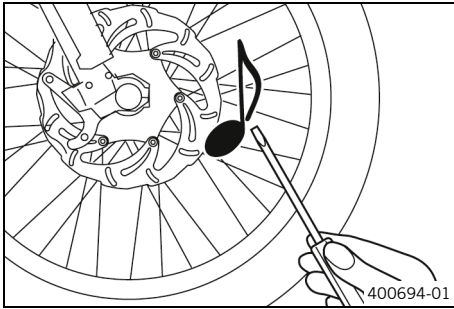

- Strike each spoke briefly using a screwdriver blade.



Info

The frequency of the sound depends on the spoke length and spoke diameter.
 If spokes of the same length and diameter vibrate with a different tone, this is an indication that the spoke tensions differ.

You should hear a high note.

- » If the spoke tension differs:
 - Correct the spoke tension. 🛠️
- Check the spoke torque.

Guideline

Spoke nipple	M3.5	3 Nm (2.2 lbf ft)
--------------	------	-------------------

Torque wrench kit (58429094000)



16.1 Overview of battery charger

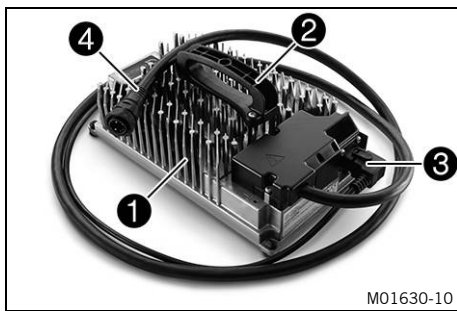

- ① Battery charger
- ② Carrying handle
- ③ Power cord
- ④ Charging cable

16.2 Positioning the battery charger



Warning

Risk of injury If the battery charger is used incorrectly, its intrinsic safety cannot be guaranteed.

The battery charger is only suitable for use with a traction battery.

- Only use the battery charger with a traction battery.
- Only operate the battery charger using household sockets with a ground conductor.
- Do not use any additional adapters or extensions.
- Follow the applicable safety instructions of the power connection.



Warning

Risk of injury There is a risk of electric shock if the battery charger or the cables have been manipulated or damaged.

The battery charger does not contain any parts which require maintenance.

- Do not modify the battery charger or the cables.
- Only use original cables.
- Never open the battery charger housing.
- Do not insert any objects into the battery charger housing from the outside.
- Do not use the battery charger if cables, plugs, or parts of the battery charger have been damaged or are soiled.

i Info

The battery charger contains sensitive electronics and must be handled with appropriate care.

The battery charger may be damaged or destroyed if it is dropped, knocked or otherwise subject to mechanical overload.

When transporting the battery charger, ensure appropriate means of securing the cargo.

Damage caused due to improper handling or improper transport is excluded from the manufacturer warranty.

The battery charger only meets **IP66** when the original power cord is being used.

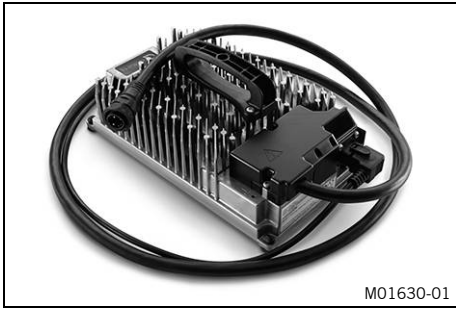

- Place the battery charger on a firm, level, and horizontal surface.

i Info
Despite **IP66**, the battery charger should only be used in a dry environment, as moisture may penetrate into the interior when connecting and disconnecting the connections.

- Check the battery charger and mains cable for external damage.
- Ensure the battery charger is adequately ventilated.
- Use the battery charger in the temperature range permitted.

Guideline

Ambient temperature	-20 ... 50 °C (-4 ... 122 °F)
Temperature range of the LV traction battery	0 ... 50 °C (32 ... 122 °F)
Do not operate the battery charger directly in a warm environment if it has previously been stored in a cold environment.	

i Info
The change in temperature can cause moisture to condense on the battery charger.

- Ensure that the power plug for the battery charger always remains easily accessible.



16.3 Charging the LV traction battery



Caution

Danger of burns The metal housing of the battery charger becomes hot during operation.

- Only touch the battery charger by the carrying handle.
- After charging, allow the battery charger to cool before stowing it away.

Note

Material damage The power supply will be damaged in the event of an overload.

- Ensure that the power outlet can supply the steady current required and is protected by a suitable fuse.

Fuse protection at mains voltage 100 V minimum	15 A
Fuse protection at mains voltage 120 V minimum	13 A
Fuse protection at mains voltage 230 V minimum	10 A



Note

Environmental hazard A lithium-ion battery (LV traction battery) contains components and elements that are harmful to the environment.

- Never throw a LV traction battery into the household trash.
- Dispose of the LV traction battery properly and in compliance with the applicable regulations. (Your authorized KTM workshop will be glad to help.)



Info

Do not activate the vehicle while the battery charger is connected to the LV traction battery. If the vehicle is activated during the charging process, the vehicle switches to the malfunction state.

i Info

If the temperature of the LV traction battery exceeds the permissible value while it is being charged, the battery charger stops charging. The malfunction is displayed on the multifunctional element. Once the temperature of the LV traction battery returns to the permissible range, charging is resumed automatically.

Preparatory work

- Position the battery charger. (📖 p. 88)
- Press and hold the On/Off button until the multifunctional element goes out.
- Remove the magnetic switch ☒ from the holder on the handlebar.

Main work

- Remove charging socket protection cap ❶.

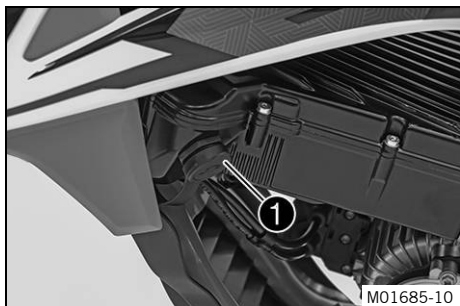

- Remove charging plug protection cap ❷.

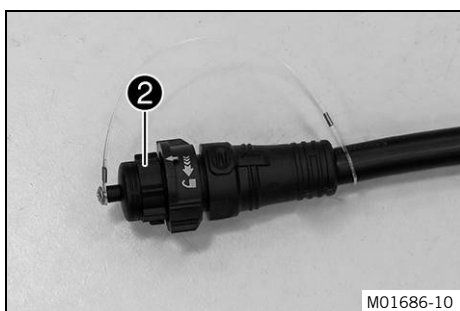

- Make sure that all plugs, bushings, and cables are dry.

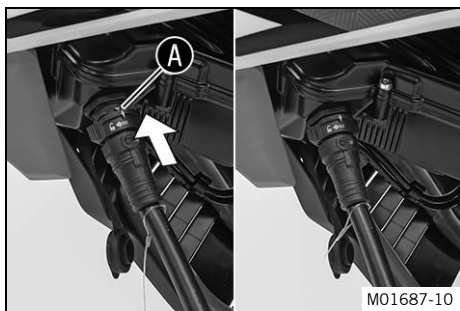

Warning

Risk of injury The intrinsic safety of the LV traction battery can only be guaranteed if the original battery charger is used.

The LV traction battery may only be charged with the original battery charger.

- Only use the original battery charger to charge the LV traction battery.

- Connect the battery charger to the LV traction battery.

Guideline

Observe plug marking A .
Insert the plug straight so that the contacts are not bent.

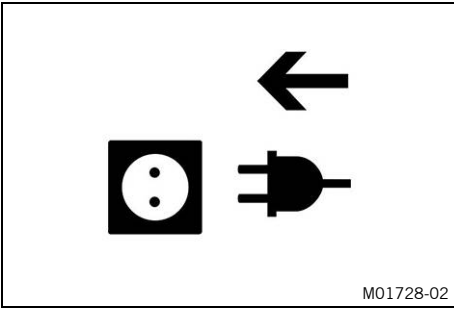

- Connect the power plug for the battery charger to the mains connection.
 - ✓ Charging starts automatically.
 - ✓ The multifunctional element indicates the charging level.
- Monitor the charging level of the LV traction battery on the multifunctional element (📖 p. 20).

i Info
 It is recommended not to leave the vehicle unattended for long periods during charging.
 When charging is complete, three beeps are emitted and all segments of the charging level indicator light up continuously.

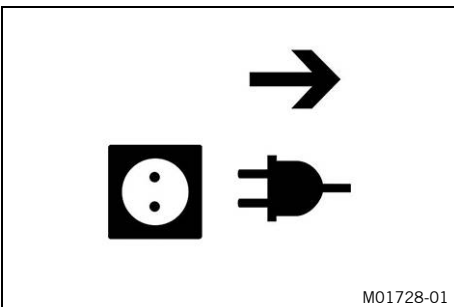

- Press and hold the On/Off button until the multifunctional element goes out.
- Make sure that all plugs, bushings, and cables are dry.
- Disconnect the battery charger power plug from the mains connection.

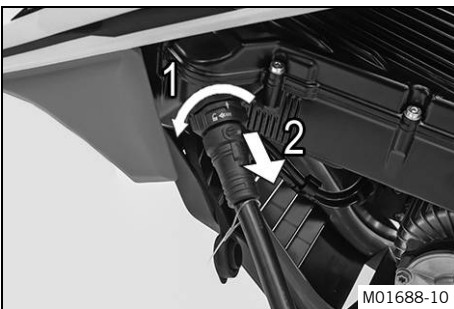

- Unlock the charging plug lock counterclockwise and disconnect the charging cable from the LV traction battery.

Guideline

Pull on the structured part of the plug. Do not pull on the cable.

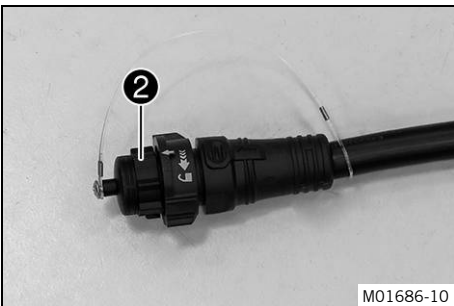

- Mount charging plug protection cap ②.

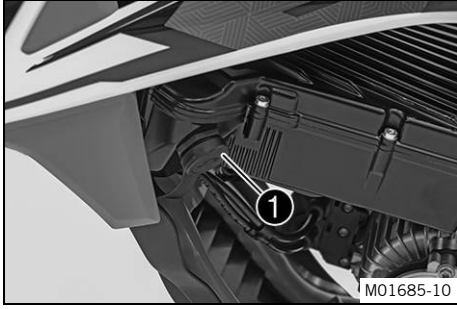

- Check charging socket protection cap ①.
 - » If the charging socket protection cap is dirty:
 - Clean the charging socket protection cap without water or compressed air.
 - » If the charging socket protection cap is damaged or worn:
 - Change the charging socket protection cap.
- Mount the charging socket protection cap.

Finishing work

- Mount the magnetic switch ☒ on the holder on the handlebar.

17.1 Cooling

The LV traction battery ❶ and the electric motor ❷ are air-cooled.

Cooling is effected by the air stream.

The lower the speed, the less the cooling effect. Dirty cooling fins also reduce the cooling effect.

18.1 Cleaning the motorcycle

Note

Material damage Components become damaged or destroyed if a pressure cleaner is used incorrectly.

The high pressure forces water into the electrical components, connectors, throttle cables, and bearings, etc. Pressure which is too high causes malfunctions and destroys components.

- Do not direct the water jet directly on to electrical components, connectors, throttle cables or bearings.
- Maintain a minimum distance between the nozzle of the pressure cleaner and the component.

Minimum clearance 60 cm (23.6 in)



Note

Environmental hazard Hazardous substances cause environmental damage.

- Dispose of oils, grease, cleaning agents, brake fluid etc. properly and in compliance with the applicable regulations.



Info

Clean the motorcycle regularly to maintain its value and appearance over a long period. Avoid direct sunshine when cleaning the motorcycle.

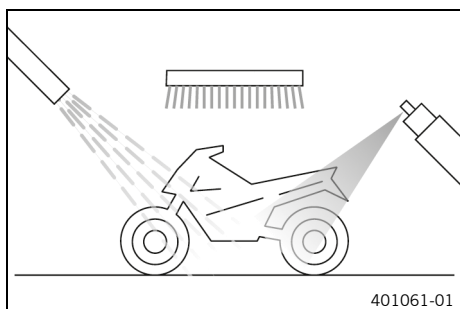

- Remove the coarse dirt particles with a gentle water jet.

Guideline

Do not remove the bearing bridge of the engine sprocket during the entire operation.

- Spray the heavily soiled parts with a normal commercial motorcycle cleaner and clean using a brush.

Motorcycle cleaner (📖 p. 106)



Info

Use warm water containing normal motorcycle cleaner and a soft sponge. Never apply motorcycle cleaner to the dry motorcycle. Always rinse the motorcycle with water before use.

- Clean the motorcycle thoroughly with a soft water jet, then allow to dry.



Warning

Danger of accidents Moisture and dirt impair the brake system.

- Explain to your child that he or she must brake carefully several times to dry out and remove dirt from the brake linings and the brake discs.

- After cleaning, your child should ride a short distance until the brake system has dried through careful braking.



Info

The heat causes the water to evaporate even in inaccessible parts of the vehicle.

- After the motorcycle has cooled down, lubricate all moving parts and pivot points.
- Clean the chain. (📖 p. 59)

- Treat bare metal with a corrosion inhibitor.

Guideline

Corrosion inhibitor must not come into contact with the brake discs.

Preserving materials for paints, metal and rubber
(📖 p. 106)

- Treat all plastic parts and powder-coated parts with a mild cleaning and care product.

Special cleaner for glossy and matte paint finishes, metal and plastic surfaces (📖 p. 106)



19.1 Storage

i Info

If the motorcycle is not being used for an extended length of time, additional measures are recommended. Before storing the motorcycle, check all parts for function and wear. If service, repairs, or replacements are necessary, you should do this during the storage period (less workshop overload). This allows you to avoid long waiting periods when the next season starts.

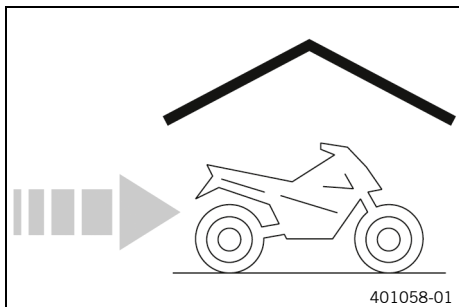

- Clean the motorcycle. (📖 p. 94)
- Check tire pressure. (📖 p. 86)
- Charge the LV traction battery. (📖 p. 89)

Guideline

Stop charging at 30 %.

- ✓ The last segment lights up yellow.

i Tip

If necessary, drain the LV traction battery sufficiently.

- Store the vehicle in a dry location that is not subject to large fluctuations in temperature.

Guideline

Ideal storage temperature	10 ... 20 °C (50 ... 68 °F)
---------------------------	-----------------------------

i Info

KTM recommends jacking up the motorcycle.

- Raise the motorcycle with a lift stand. (📖 p. 46)
- Cover the motorcycle with a tarp or cover that is permeable to air.

Guideline

Do not use any non-porous materials, as moisture cannot escape and corrosion can occur.

19.2 Preparing for use after storage

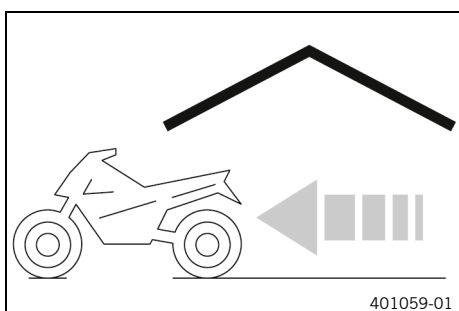

- Remove the motorcycle from the lift stand. (📖 p. 46)
- Charge the LV traction battery. (📖 p. 89)
- Perform checks and maintenance measures when preparing for use. (📖 p. 24)
- Take a test ride.



The malfunctions are indicated by malfunction indicator lamp **1** and by acoustic signals that sound at the same time.

i Tip

As a first measure for all malfunctions, switch off the vehicle using the On/Off button, wait one minute, and switch it on again.

If a malfunction is not eliminated by the steps specified here, or a blink code is not listed, an authorized KTM workshop will be happy to help you.

i Info

The pause between the signals of the 1st digit is 0.25 seconds.

The pause between the 1st and 2nd digits is 1 second.

The pause between the signals of the 2nd digit is also 0.25 seconds.

The pause until the blink code repeats is 3 seconds.

Faults	Possible cause	Action
Blink code 11	Malfunction in the throttle grip	– Check the throttle grip for damage. 🛠️
Blink code 12	Malfunction in the throttle grip	– Check the throttle grip for damage. 🛠️
Blink code 14	Throttle grip actuated during activation	– Do not operate the throttle grip during activation.
Blink code 24	System temperature too high	– Allow the vehicle to cool down, clean the cooling surfaces.
Blink code 31	Malfunction during charging	– Disconnect the battery charger from the vehicle and mains connection, wait 1 minute, restart the charging process.
Blink code 33	System temperature too high	– Allow the vehicle to cool down, clean the cooling surfaces.
Blink code 34	System temperature too low	– Park the vehicle in a warmer environment.
Blink code 41	Vehicle moved during activation	– Do not move the vehicle during activation.
Blink code 42	Motor speed outside the permissible range	– Do not roll backward with the vehicle.
Blink code 43	System temperature too high	– Allow the vehicle to cool down, clean the cooling surfaces.
Blink code 71	Malfunction during charging	– Disconnect the battery charger from the vehicle and mains connection, wait 1 minute, restart the charging process. – Replace the charging cable. 🛠️
Blink code 72	Malfunction during charging	– Disconnect the battery charger from the vehicle and mains connection, wait 1 minute, restart the charging process. – Replace the charging cable. 🛠️
Blink code 73	Malfunction during charging	– Disconnect the battery charger from the vehicle and mains connection, wait 1 minute, restart the charging process. – Replace the charging cable. 🛠️
Blink code 83	Transport mode activated	– Deactivate transport mode. 🛠️

Faults	Possible cause	Action
Blink code 85	Malfunction during charging	<ul style="list-style-type: none">– Disconnect the battery charger from the vehicle and mains connection, wait 1 minute, restart the charging process.– Replace the charging cable. 🛠️
Blink code 88	Malfunction in the On/Off button	<ul style="list-style-type: none">– Deactivate the vehicle, wait 4 minutes, reactivate the vehicle.– Check the On/Off button for damage. 🛠️

21.1 Engine

Design	Brushless DC motor
Nominal power	2 kW (3 hp)
Maximum electric power	5 kW (7 hp)
Recuperation (SX-E 5)	available in ride mode 3 and 6
Maximum torque depending on ride mode approx. (SX-E 3)	
Ride mode 1	6 Nm (4.4 lbf ft)
Ride mode 2	9 Nm (6.6 lbf ft)
Ride mode 3	9.7 Nm (7.15 lbf ft)
Ride mode 4	10.5 Nm (7.74 lbf ft)
Ride mode 5	11.2 Nm (8.26 lbf ft)
Ride mode 6	12 Nm (8.9 lbf ft)
Maximum torque depending on ride mode approx. (SX-E 5)	
Ride mode 1	6 Nm (4.4 lbf ft)
Ride mode 2	9 Nm (6.6 lbf ft)
Ride mode 3	10.5 Nm (7.74 lbf ft)
Ride mode 4	12 Nm (8.9 lbf ft)
Ride mode 5	13.8 Nm (10.18 lbf ft)
Ride mode 6	13.8 Nm (10.18 lbf ft)
Theoretical maximum speed (unloaded) (SX-E 3)	
Ride mode 1	11 km/h (6.8 mph)
Ride mode 2	19 km/h (11.8 mph)
Ride mode 3	31 km/h (19.3 mph)
Ride mode 4	46 km/h (28.6 mph)
Ride mode 5	58 km/h (36 mph)
Ride mode 6	65 km/h (40.4 mph)
Theoretical maximum speed (unloaded) (SX-E 5)	
Ride mode 1	11 km/h (6.8 mph)
Ride mode 2	19 km/h (11.8 mph)
Ride mode 3	46 km/h (28.6 mph)
Ride mode 4	65 km/h (40.4 mph)
Ride mode 5	77 km/h (47.8 mph)
Ride mode 6	77 km/h (47.8 mph)
Maximum motor speed (SX-E 3)	5,100 rpm
Maximum motor speed (SX-E 5)	6,000 rpm
Cooling	Air cooling

21.2 Chassis

Frame	Central tube frame of chrome molybdenum steel tubing, powder-coated
Fork (SX-E 3)	WP XACT
Fork (SX-E 5)	WP XACT 35
Shock absorber (SX-E 3)	WP Suspension
Shock absorber (SX-E 5)	WP XACT 5735
Standard rider weight (SX-E 3)	15 ... 35 kg (33 ... 77 lb.)
Standard rider weight (SX-E 5)	25 ... 35 kg (55 ... 77 lb.)
Suspension travel (SX-E 3)	
front	144 mm (5.67 in)
rear	133 mm (5.24 in)
Suspension travel (SX-E 5)	
front	205 mm (8.07 in)
rear	185 mm (7.28 in)
Fork offset	22 mm (0.87 in)
Brake system	
front	Disc brake with 2-piston brake caliper
rear	Disc brake with 2-piston brake caliper
Brake disc diameters	
front	160 mm (6.3 in)
rear	160 mm (6.3 in)
Brake discs - wear limits	
front	2.2 mm (0.087 in)
rear	2.2 mm (0.087 in)
Offroad tire pressure	
front	1.0 bar (15 psi)
rear	1.0 bar (15 psi)
Secondary drive ratio	08:46
Chain	1/2 x 3/16"
Rear sprockets available	45, 46, 47
Steering head angle (SX-E 3)	63°
Steering head angle (SX-E 5)	66°
Wheelbase (SX-E 3)	1,017 mm (40.04 in)
Wheelbase (SX-E 5)	1,032 mm (40.63 in)
Seat height unloaded (SX-E 3)	555 ... 600 mm (21.85 ... 23.62 in)
Seat height unloaded (SX-E 5)	615 ... 665 mm (24.21 ... 26.18 in)
Ground clearance unloaded (SX-E 3)	152 mm (5.98 in)
Ground clearance unloaded (SX-E 5)	252 mm (9.92 in)
Ready-to-ride weight approx. (SX-E 3)	39.2 kg (86.4 lb.)
Ready-to-ride weight approx. (SX-E 5)	40.5 kg (89.3 lb.)
Maximum permissible overall weight (SX-E 3)	80 kg (176 lb.)
Maximum permissible overall weight (SX-E 5)	95.5 kg (210.5 lb.)

21.3 Electrical system



Air-cooled lithium-ion battery (LV traction battery) (SX-E 3)	A20045053000	Voltage (nominal): 43.2 V Capacity: 648 Wh Approx. charging time, 0 % to 80 %: 45 min Approx. charging time, 0 % to 100 %: 70 min Maintenance-free
Air-cooled lithium-ion battery (LV traction battery) (SX-E 5)	45445053300	Voltage (nominal): 43.2 V Capacity: 907 Wh Approx. charging time, 0 % to 80 %: 45 min Approx. charging time, 0 % to 100 %: 70 min Maintenance-free
Battery charger for LV traction battery	45429074044	Nominal voltage: 100 ... 240 V Grid frequency: 50 ... 60 Hz Power: 900 W

21.4 Tires

Validity	Front tire	Rear tire
(SX-E 3)	60/100 - 10 33J TT MAXXIS MAXXCROSS MX-ST+	2.75 - 10 38J TT MAXXIS MAXXCROSS MX-ST+
(SX-E 5)	60/100 - 12 36J TT MAXXIS MAXXCROSS MX-ST+	2.75 - 10 38J TT MAXXIS MAXXCROSS MX-ST+

The tires specified represent one of the possible series production tires. For alternative manufacturers, if any, contact an authorized dealer or qualified tire dealership. If local road approval regulations apply, these and the respective technical specifications must be observed. Additional information is available in the Service section under:
KTM.COM

21.5 Fork
21.5.1 SX-E 3

Fork article number	A200C101W109000	
Fork	WP XACT	
Fork length	624 mm (24.57 in)	
Spring length with preload spacer(s)	337.5 mm (13.287 in)	
Oil capacity, external mechanism	10 ml (0.34 fl. oz.)	Fork oil (SAE 4) (48601166S1) ( p. 105)
Oil capacity, right cartridge	230 ml (7.78 fl. oz.)	Fork oil (SAE 4) (48601166S1) ( p. 105)
Oil capacity, left cartridge	200 ml (6.76 fl. oz.)	Fork oil (SAE 4) (48601166S1) ( p. 105)

21.5.2 SX-E 5

Fork article number	A400C102X106000	
Fork	WP XACT 35	

Rebound damping		
Comfort	15 clicks	
Standard	12 clicks	
Sport	10 clicks	
Air pressure	1 bar (15 psi)	
Fork length	685 mm (26.97 in)	
Spring rate	2 N/mm (11 lb/in)	
Spring length with preload spacer(s)	337.5 mm (13.287 in)	
Oil capacity external mechanism left	25 ± 5 ml (0.85 ± 0.17 fl. oz.)	Fork oil (SAE 4) (48601166S1) (📖 p. 105)
Oil capacity, right cartridge	225 ml (7.61 fl. oz.)	Fork oil (SAE 4) (48601166S1) (📖 p. 105)
Grease capacity, left cartridge	6 g (0.21 oz)	Special grease (00062010053) (📖 p. 106)

21.6 Shock absorber

21.6.1 SX-E 3

Shock absorber article number	A200C443W915102	
Shock absorber	WP Suspension	
Spring preload		
Standard	3 clicks	
Spring rate		
"Comfort" variant	30 N/mm (171 lb/in)	
"Standard" variant	35 N/mm (200 lb/in)	
"Sport" variant	40 N/mm (228 lb/in)	
	 Info The spring rate can only be changed by replacing the shock absorber.	
Spring length	125 ± 2 mm (4.92 ± 0.08 in)	
Fitted length		
"Comfort" variant	252.9 ± 2 mm (9.957 ± 0.08 in)	
"Standard" variant	253.1 ± 2 mm (9.965 ± 0.08 in)	
"Sport" variant	253.3 ± 2 mm (9.972 ± 0.08 in)	

21.6.2 SX-E 5

Shock absorber article number	03.18.7U.02	
Shock absorber	WP XACT 5735	
Low-speed compression damping		
Comfort	18 clicks	
Standard	15 clicks	
Sport	12 clicks	
High-speed compression damping		
Comfort	2.5 turns	
Standard	2 turns	

Sport	1.5 turns
Rebound damping	
Comfort	17 clicks
Standard	15 clicks
Sport	13 clicks
Spring preload	3 mm (0.12 in)
Spring rate	
Weight of rider: 15 ... 25 kg (33 ... 55 lb.)	25 N/mm (143 lb/in)
Weight of rider (standard): 25 ... 35 kg (55 ... 77 lb.)	30 N/mm (171 lb/in)
Weight of rider: 35 ... 45 kg (77 ... 99 lb.)	35 N/mm (200 lb/in)
Spring length	130 mm (5.12 in)
Gas pressure	10 bar (145 psi)
Static sag	12 mm (0.47 in)
Rider sag	80 mm (3.15 in)
Fitted length	275 mm (10.83 in)
Shock absorber oil	Shock absorber fluid (SAE 2.5) (50180751S1) (📖 p. 105)

21.7 Chassis tightening torques

Screw, brake line holder on fork protector	EJOT PT®K60x20-AL	2 Nm (1.5 lbf ft)
Screw, brake line holder on link fork	EJOT SF®M5x10-K	2 Nm (1.5 lbf ft)
Screw, seat quick release thrust bearing	-	0.65 Nm (0.479 lbf ft)
Screw, magnetic switch on handlebar	M3	0.8 Nm (0.59 lbf ft)
Spoke nipple	M3.5	3 Nm (2.2 lbf ft)
Screw, fixed grip	M4	5 Nm (3.7 lbf ft)
Screw, throttle grip	M4	3 Nm (2.2 lbf ft)
Remaining nuts, chassis	M5	5 Nm (3.7 lbf ft)
Remaining screws, chassis	M5	5 Nm (3.7 lbf ft)
Screw, brake assembly	M5	5 Nm (3.7 lbf ft)
Screw, brake linings	M5	8 Nm (5.9 lbf ft)
Nut, push rod ball joint on the rear brake cylinder (SX-E 5)	M6	10 Nm (7.4 lbf ft)
Nut, push rod, foot brake lever (SX-E 5)	M6	6 Nm (4.4 lbf ft)
Rear fairing screw	M6	8 Nm (5.9 lbf ft)
Remaining nuts, chassis	M6	10 Nm (7.4 lbf ft)
Remaining screws, chassis	M6	10 Nm (7.4 lbf ft)
Screw, chain sliding guard	M6	3 Nm (2.2 lbf ft)
Screw, fender	M6	6 Nm (4.4 lbf ft)
Screw, fork stub	M6	10 Nm (7.4 lbf ft)

Loctite®243™

21 TECHNICAL SPECIFICATIONS

Screw, front brake disc	M6	14 Nm (10.3 lbf ft) Loctite®243™
Screw, rear brake disc	M6	14 Nm (10.3 lbf ft) Loctite®243™
Screw, splash protector	M6	7 Nm (5.2 lbf ft)
Screw, start number plate	M6	4 Nm (3 lbf ft)
Screw, subframe connection	M6	10 Nm (7.4 lbf ft)
Threaded adapter for front fairing	M6	8 Nm (5.9 lbf ft)
Nut, foot brake lever (SX-E 5)	M8	22 Nm (16.2 lbf ft)
Nut, rim lock	M8	10 Nm (7.4 lbf ft)
Remaining nuts, chassis	M8	25 Nm (18.4 lbf ft)
Remaining screws, chassis	M8	25 Nm (18.4 lbf ft)
Screw, bottom triple clamp	M8	15 Nm (11.1 lbf ft)
Screw, chain securing guide	M8	15 Nm (11.1 lbf ft)
Screw, chain sliding piece	M8	15 Nm (11.1 lbf ft)
Screw, engine bracket	M8	25 Nm (18.4 lbf ft) Loctite®243™
Screw, front brake caliper	M8x35	20 Nm (14.8 lbf ft) Loctite®243™
Screw, handlebar clamp	M8	20 Nm (14.8 lbf ft)
Screw, LV traction battery, front	M8x25	20 Nm (14.8 lbf ft)
Screw, LV traction battery, rear	M8x50	20 Nm (14.8 lbf ft) Loctite®243™
Screw, rear brake caliper	M8x20	20 Nm (14.8 lbf ft) Loctite®243™
Screw, rear sprocket	M8	25 Nm (18.4 lbf ft) Loctite®243™
Screw, steering stem	M8	20 Nm (14.8 lbf ft)
Screw, subframe	M8	30 Nm (22.1 lbf ft) Loctite®243™
Screw, top triple clamp	M8	20 Nm (14.8 lbf ft)
Remaining nuts, chassis	M10	45 Nm (33.2 lbf ft)
Remaining screws, chassis	M10	45 Nm (33.2 lbf ft)
Screw, bottom shock absorber	M10x52	45 Nm (33.2 lbf ft) Loctite®243™
Screw, front wheel spindle	M10	40 Nm (29.5 lbf ft) Loctite®243™
Screw, handlebar support	M10	40 Nm (29.5 lbf ft) Loctite®243™
Screw, top shock absorber	M10x42	45 Nm (33.2 lbf ft) Loctite®243™
Nut, rear wheel spindle	M12x1	40 Nm (29.5 lbf ft)
Nut, swingarm pivot	M12x1	45 Nm (33.2 lbf ft)
Nut, steering head	M20x1.5	10 Nm (7.4 lbf ft)

Brake fluid DOT 4 / DOT 5.1**Standard/classification**

- DOT

Guideline

- Use only brake fluid that complies with the specified standard (see specifications on the container) and that exhibits the corresponding properties.

Recommended supplier**Castrol**

- REACT PERFORMANCE DOT 4

MOTOREX®

- Brake Fluid DOT 5.1

Fork oil (SAE 4) (48601166S1)**Standard/classification**

- SAE (📖 p. 107) (SAE 4)

Guideline

- Use only oils that comply with the specified standards (see specifications on the container) and that exhibit the corresponding properties.

Shock absorber fluid (SAE 2.5) (50180751S1)**Standard/classification**

- SAE (📖 p. 107) (SAE 2.5)

Guideline

- Use only oils that comply with the specified standards (see specifications on the container) and that exhibit the corresponding properties.

Chain cleaner

Recommended supplier

MOTOREX®

- Chain Clean

High viscosity grease

Recommended supplier

SKF®

- LGHB 2

Long-life grease

Recommended supplier

MOTOREX®

- Bike Grease 2000

Motorcycle cleaner

Recommended supplier

MOTOREX®

- Moto Clean

Off-road chain spray

Recommended supplier

MOTOREX®

- Chainlube Offroad

Preserving materials for paints, metal and rubber

Recommended supplier

MOTOREX®

- Moto Protect

Special cleaner for glossy and matte paint finishes, metal and plastic surfaces

Recommended supplier

MOTOREX®

- Quick Cleaner

Special grease (00062010053)

Recommended supplier

Klüber Lubrication®

- Klüberfood NH1 34-401

Universal oil spray

Recommended supplier

MOTOREX®

- Joker 440 Synthetic

SAE

The SAE viscosity classes were defined by the Society of Automotive Engineers and are used for classifying oils according to their viscosity. The viscosity describes only one property of oil and says nothing about quality.

BIN	Battery identification number	Serial number of the traction battery; this is linked to the vehicle identification number.
-----	-------------------------------	---

Art. no.	Article number
ca.	circa
cf.	compare
e.g.	for example
etc.	et cetera
i.a.	inter alia
no.	number
poss.	possibly

27.1 Yellow and orange symbols

Yellow and orange symbols indicate an error condition that requires prompt intervention. Active driving aids are also represented by yellow or orange symbols.



The malfunction indicator lamp flashes – There is a malfunction in the vehicle electronic system.

PARENTS, YOUNGSTERS & OFF-HIGHWAY MOTORCYCLES



THE MSF
DIRTBIKE
SCHOOL™

The information contained in this publication is offered for the benefit of those who have an interest in riding off-highway motorcycles. The information has been compiled from publications, interviews and observations of individuals and organizations familiar with the use of off-highway motorcycles. Because there are many differences in product design, riding terrain and riding styles, there may be organizations and individuals who hold differing opinions. Consult your local motorcycle dealers or experienced off-highway motorcycle riders about appropriate riding locations in your area. Although the Motorcycle Safety Foundation will continue to publish responsible viewpoints on this subject, it must disclaim specific or general liability for the views expressed herein.

The Motorcycle Safety Foundation® (MSF) is a national not-for-profit organization promoting the safety of motorcyclists with programs in rider training, operator licensing and public information. The MSF is sponsored by BMW, BRP, Ducati, Harley-Davidson, Honda, Kawasaki, KTM, Piaggio, Polaris Motorcycles, Suzuki, Triumph and Yamaha.

Motorcycle Safety Foundation
2 Jenner, Suite 150
Irvine, CA 92618
949.727.3227
msf-usa.org

Copyright 2015
Printed: March 2015

Parents...Be Cautious

Riding Off-Highway Motorcycles (OHMs) can be an enjoyable form of outdoor recreation when done properly. With preparation, practice, and parental supervision your youngster can safely develop and expand his or her riding skills. Remember, off-highway motorcycles are not toys.

This manual is designed to assist you in the important task of teaching your youngster the safe and responsible use of an off-highway motorcycle. We urge you to read this booklet thoroughly. Also read other information provided with the motorcycle. The owner's manual contains important warnings and features of the motorcycle.

Deciding if your youngster is ready to ride an off-highway motorcycle is an important decision. The MSF strongly urges you to carefully determine your youngster's readiness to ride. There is a Readiness Checklist in Part 4 of this booklet. **Do not permit youngsters to ride an off-highway motorcycle if you doubt that they will operate the motorcycle safely.**

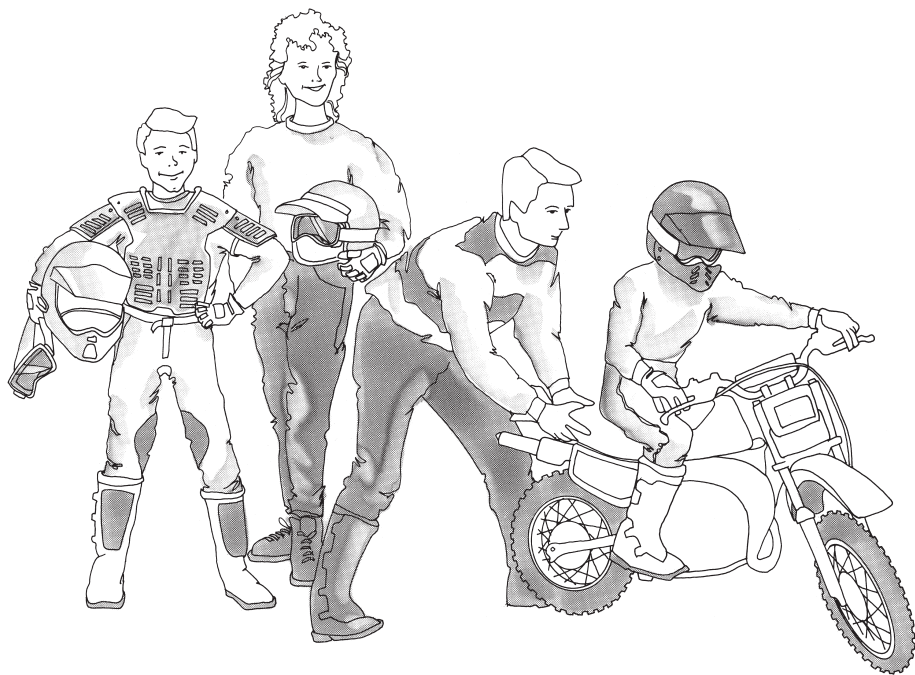

CONTENTS

INTRODUCTION

- Purpose of the Booklet 4
- Important Note to Parents 4
- Other Sources of Information 5

PART 1: Determining Your Youngster's Readiness to Ride an Off-Highway Motorcycle

- Readiness Guidelines 6
- Steps for Safe and
Responsible OHM Riding 10

PART 2: Pre-Operating Procedures and Practice

- Protective Gear and Clothing 11
- Mounting/Dismounting 12
- Mastering the Controls 13
- Learning Activities 16

PART 3: Operating Procedures and Practice

- Learning Area/Riding Area 20
- Getting Used to the Vehicle in
Motion 22
- Let's Start Riding 25

PART 4: Readiness Checklist

- Visual Perception/Motor/
Development 29
- Physical Development 32
- Social/Emotional Development 34
- Reasoning and Decision-Making
Ability 36

FINAL NOTE: To Parents 38

GLOSSARY 39

ANSWERS 41

INTRODUCTION

Purpose of the Booklet

Parents, *Youngsters and Off-Highway Motorcycles* is designed to assist you in determining if your youngster is ready to ride off-highway motorcycles (OHMs). It also provides you and your youngster with important safety information and tips on learning to ride. This booklet is divided into four parts: Part 1: Determining Your Youngster's Readiness to Ride an Off-highway Motorcycle; Part 2: Pre-operating Procedures; Part 3: Operating Procedures; Part 4: Readiness Checklist. There is information about protective gear, mounting, control operation and starting the engine. Operating procedures include starting, shifting, stopping and turning.

Important Note To Parents

Once your youngster is ready to learn to ride, YOU must be familiar with the motorcycle. You will be serving as teacher, coach, and safety supervisor for your youngster. You must know the controls, handling characteristics, maintenance requirements, and proper riding techniques. Read and understand the owner's manual and the labels provided with the vehicle. Review all instructions, requirements, and warnings with your youngster. Find out about state or local off-highway motorcycle requirements.

Other Sources Of Information

In addition to the information provided in *Parents, Youngsters and Off-Highway Motorcycles*, there are other sources for obtaining safety information. The owner's manual provides specific maintenance and operating procedures for your motorcycle. It also includes warnings and cautions, as well as operating tips. Motorcycle dealers may have other literature and safety information. Another booklet, *Tips and Practice Guide for the Off-Highway Motorcyclist*, gives detailed riding procedures.

The MSF *DirtBike School*SM offers training on how to ride off-highway motorcycles. The course is available to youth as young as six years of age, as well as to adults. Call toll-free 877.288.7093 to enroll or for more information. To find out more on the internet, visit dirtbikeschool.com.

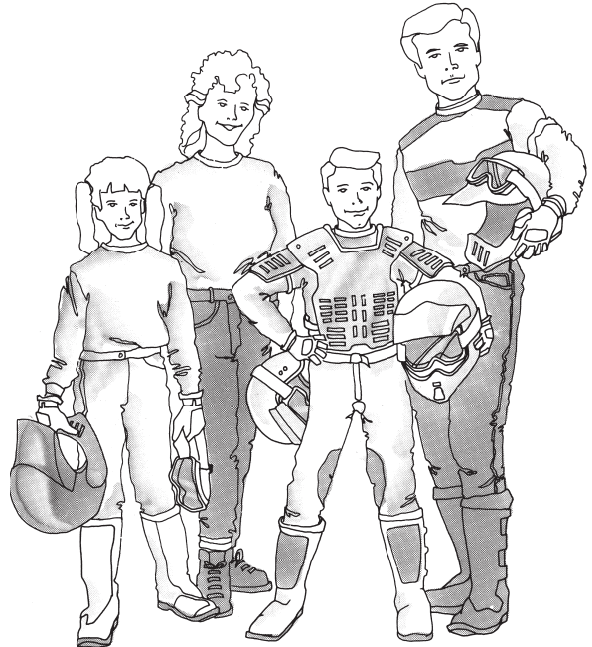

PART 1

DETERMINING YOUR YOUNGSTER'S READINESS TO RIDE AN OFF-HIGHWAY MOTORCYCLE

The first important decision you will have to make concerning your youngster and off-highway motorcycles (OHMs) is whether your youngster is ready to ride. There are several factors that you must consider carefully.

There is no certain way to predict that your child is able to ride an OHM safely. However, the following information is a guide to help you determine your youngster's readiness to ride. Only parents can decide if their youngster has the qualities necessary to operate an off-highway motorcycle safely.

Readiness Guidelines

PHYSICAL DEVELOPMENT

Physical size and ability are important considerations. For example, a youngster must be big enough to hold the motorcycle up, get on, and comfortably sit on the seat with both feet touching the ground.

Also make sure your youngster can comfortably reach and work all the controls. For example, can they turn the handlebars all the way to the right and left? Can they easily use their feet to work the brake pedal and gearshift lever? Can they operate the throttle and brake levers while they hold onto the handgrips? If not, the youngster is not physically ready to ride this OHM. Refer to the owner's manual to check for possible adjustments in the position of some of the controls.

PART 1

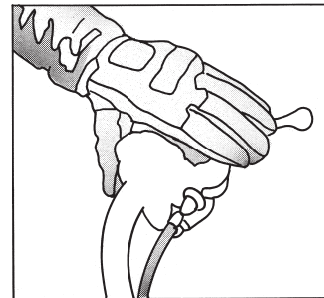
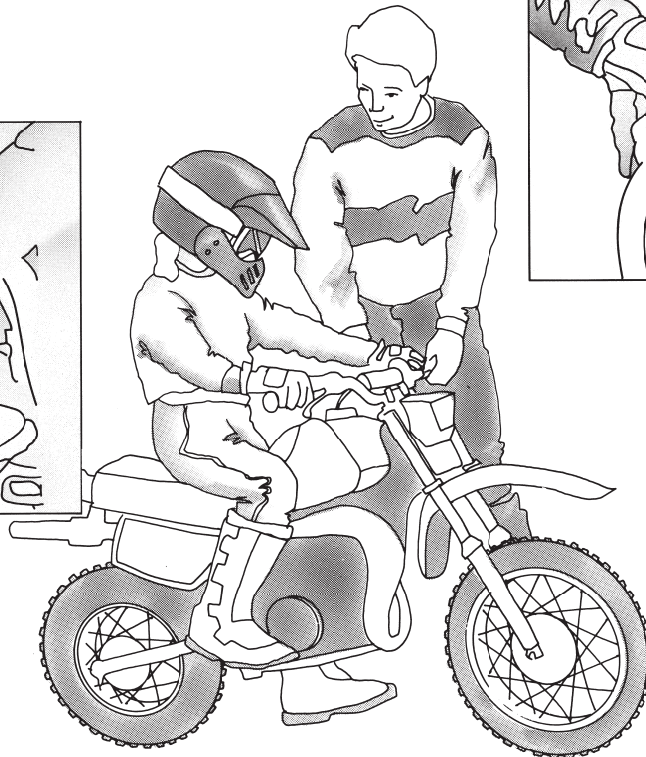
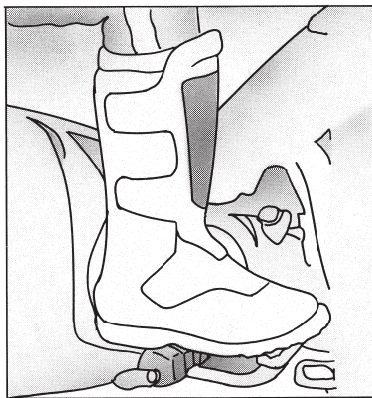

PART 1

Additional signs of physical readiness can be observed in your youngster's other play activities. In general, a youngster should be well-coordinated, having good balance and agility. This coordination can be demonstrated by the abilities to jump rope, skate, skateboard, ride a bicycle, etc. If a youngster cannot perform well in these types of activities, more physical development is needed.

SOCIAL/EMOTIONAL DEVELOPMENT

How a youngster behaves in a social setting can be a sign of social/emotional development. A youngster needs to know about and understand rules. Certain rules are necessary for the safe operation of any vehicle. Youngsters must be willing to follow rules. A good sign is a youngster who obeys rules set by parents. A youngster who does not follow rules is not ready for an OHM.

One indicator that a youngster is ready to ride an

OHM is when they demonstrate a safety-conscious attitude and are aware of possible injury from reckless OHM operation. If the youngster has a habit of recklessness or is often involved in accidents while using bicycles or skateboards, the youngster is not ready to ride an OHM.

REASONING AND DECISION-MAKING ABILITY

Youngsters should have some knowledge about what may happen if something is done wrong. They must understand that unsafe actions can result in injury. An example of this is knowing the need to look in both directions before crossing a street when walking to school. The ability to make good decisions relates to a youngster's ability to reason. When presented with a problem, the youngster should be able to come up with a sensible answer. Ask your youngster to tell you what causes accidents and injuries. Your youngster needs to be able to tell

what causes accidents and how to avoid them. In general, a youngster should understand that he or she can get hurt as a result of making poor choices.

VISUAL PERCEPTIONS AND MOTOR DEVELOPMENT

This area involves how well a youngster sees and how vision is used with other physical movements. In other words, can a youngster see and react with the proper hand, foot, or body movement?

Several types of visual characteristics are important. The ability to see to the sides while looking straight ahead is called peripheral or side vision. You can determine a youngster's side vision by having him or her look straight ahead while you move objects to the side. The youngster should be able to see objects ninety degrees to the side while looking straight ahead. Rider awareness and safety improves with good side vision.

Being able to judge distance is another visual skill helpful when operating an OHM. Is your youngster able to tell how far one object is from another, or which of two objects is closer? OHM riding requires a person to judge distance and react properly.

Being good at playing video games, hitting a baseball, etc., is a good sign that a youngster's eye and hand movements are fairly well coordinated.

In summary, you must consider many things before you decide to put your youngster on an OHM. There is no exact formula to use in making this decision. The Readiness Checklist, Part 4, can assist you with some points to evaluate. If you are not able to check-off most of the statements, your youngster is probably not ready to ride an OHM.

PART 1

Steps For Safe And Responsible OHM Riding

Once you determine that OHM use is proper for your youngster, it is time to prepare yourself as a good OHM teacher and supervisor.

STEP ONE: Educate Yourself about OHM Safety and Proper Riding Techniques

You must learn as much as possible about off-highway motorcycles in general, and especially your youngster's motorcycle. You must be qualified to instruct and supervise your youngster. This means that you will need to understand the features of the motorcycle and proper riding techniques. The best source of information is the owner's manual supplied with the motorcycle. Read the owner's manual before you begin to instruct your youngster about OHM safety. Pay particular attention to the warning labels and stickers on the motorcycle.

STEP TWO: Teach Your Youngster Safe and Proper Riding Techniques

Teaching your youngster off-highway motorcycling is a step-by-step process. It begins with safety rules and moves to actual riding techniques. Since youngsters learn at different rates, it will be up to you to set the pace of your youngster's progress. At some point you may decide that he or she is not ready to ride an OHM.

STEP THREE: Avoid Unsafe Situations Through Close Supervision

ALWAYS closely supervise your youngster's riding. This is true even if your youngster has learned and mastered the rules and skills of safe OHM riding. Youngsters can get tired easily and become careless. They do not always see everything that is important around them. Your close supervision and good judgment are important.

Protective Gear And Clothing

The nature of off-highway riding demands that your youngster wear proper protective gear. Motorcycle riders should ALWAYS wear a helmet, eye protection, gloves, long pants, a long-sleeved shirt or jacket, and over-the-ankle boots. Anything less is not adequate protection. NEVER let anyone ride an off-highway motorcycle without a Department of Transportation (DOT) compliant motorcycle helmet. Be sure the fit is correct. It should be snug but not tight. It must be properly fastened.

Protective gear is necessary in any weather, even when the temperature is warm. In cooler weather you should dress your youngster with additional layers of clothing. Some riders choose to wear a kidney belt and chest or back protector for additional protection. On the right is a drawing of well-equipped riders. Show this drawing to your youngster and point out what is important.

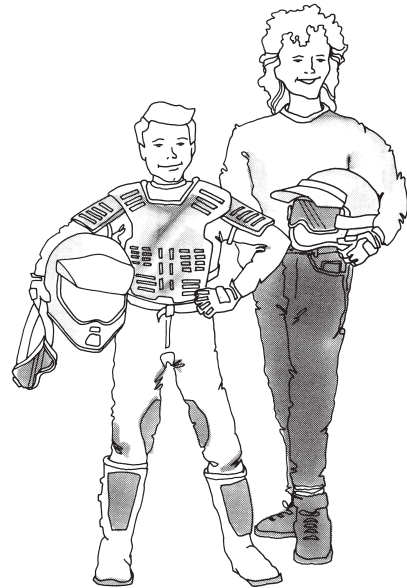

PART 2

Mounting/Dismounting

Have your youngster wear safety gear whenever getting on a motorcycle. This action will stress the importance of safety gear and help develop safe riding habits.

Mounting is typically from the left side. To mount from the left, point the handlebars straight. While squeezing the front brake lever, swing the right leg over the seat and place the right foot on the ground. Both feet should be in contact with the ground while sitting on the motorcycle. Dismounting reverses the procedure: the kickstand is placed fully down. With the left foot on the ground, the handlebars straight and the front brake lever squeezed, the right leg is swung over the seat and the foot touches the ground.

Correct riding posture helps your youngster operate the controls. Proper straight line riding posture includes:

- Head and eyes up, looking well ahead.
- Shoulders relaxed, back straight.

- Elbows bent, slightly out and away from the body.
- Hands on the handlebars.
- Knees in toward the tank.
- Feet on the footpegs, toes pointing straight ahead.

The hand and foot controls are important to riding safely. While riding, both hands should be kept on the handlebars and both feet on the footpegs of the motorcycle. Removing a hand or foot can reduce the ability to control the motorcycle.

An off-highway motorcycle rider will need to shift body weight in certain situations. This is especially true in maneuvers such as turning, negotiating hills, and riding on bumpy terrain. Your youngster should be able to operate the controls during these maneuvers. Now is a good time to make sure your youngster can reach the controls from different body positions. Have the youngster remount. Turn the handlebars full left

and full right. See that this can be done easily. Next have the youngster slide up and back on the seat. Mention that body movement is important. Body movement and shifting weight help to control the motorcycle.

(Go through these control exercises with the motorcycle's engine OFF.)

Mastering The Controls

Show your youngster how to use each control as you describe its action. Refer to the owner's manual to learn control location and function before instructing your youngster. Test yourself by operating the controls. Have your youngster dress in the proper protective gear and sit on the machine as you point out each control. It is important to have your youngster wear all the protective gear whenever sitting on an off-highway motorcycle.

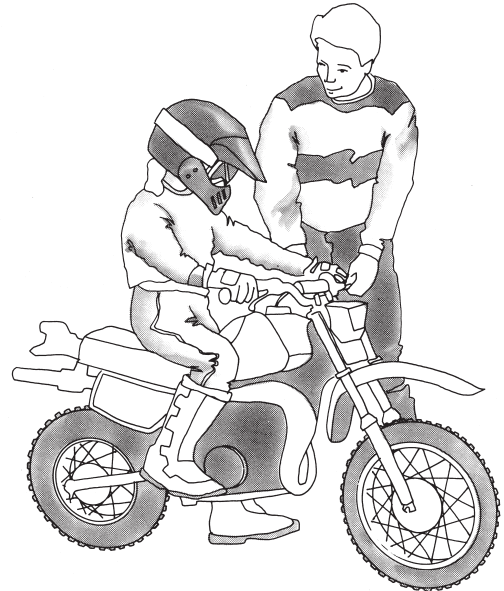

PART 2

BRAKES

Most small off-highway motorcycles have a hand lever on the right handlebar which operates the front brake. Most also have a foot pedal on the right side to operate the rear brake. Refer to the owner's manual for correct brake location and operation.

Explain and demonstrate proper braking procedure. Be sure your youngster can apply the brake(s) properly while seated and without looking down. Smooth operation should be encouraged.

THROTTLE CONTROL

Explain to your youngster that twisting the throttle control back will make the motorcycle go faster. Closing the throttle control slows the motorcycle.

Youngsters need practice using the throttle control smoothly. They tend to use it like an on/off switch. With the engine off, have your youngster

move the throttle to various positions. Practice turning the handlebars and using the throttle at the same time.

ENGINE STOP SWITCH

Explain to your youngster how to use the engine stop switch to turn off the engine. With the engine off, show how the stop switch works. Later, your youngster can practice using the stop switch when the engine is actually running.

CLUTCH/SHIFT LEVER

Some small OHMs do not have a clutch lever; some don't have a shift lever either. This section applies only to motorcycles with a shift lever. Those that do have a shift lever may have different shift patterns. Refer to your owner's manual for proper shifting instructions. It is important to learn how the shift lever works.

Explain that it is possible to shift the motorcycle with the shift lever in order to ride at different speeds.

Have your youngster practice shifting with the engine off. The shift lever, clutch lever (if equipped), and throttle control work together to move the motorcycle. When shifting to first gear from neutral the throttle is closed, the clutch lever is squeezed, and the front brake is applied before moving the shift lever into first gear. When starting out, the front brake is released. The throttle is gradually opened while the clutch is slowly released. If the clutch is released too quickly, or too much throttle is applied, the motorcycle may lunge forward causing loss of control. With the engine off, have your youngster practice upshifts, downshifts, and locating neutral.

SPEED LIMITERS

(supervisor control feature)

Some models come equipped with a removable exhaust restrictor, or another feature which reduces maximum speed. Refer to your owner's manual or talk to your dealer about this.

PART 2

NAME THE MOTORCYCLE PARTS (Typical)

Have your youngster write the number of the motorcycle part or control on the correct line for the diagrams shown. (*Answer Guide on Page 42*)

1. Clutch lever
2. Hand brake lever
3. Foot brake lever or pedal
4. Throttle
5. Choke or enriching device
6. Engine stop switch
7. Gas cap/tank vent
8. Starter (kick)
9. Electric starter (if equipped)

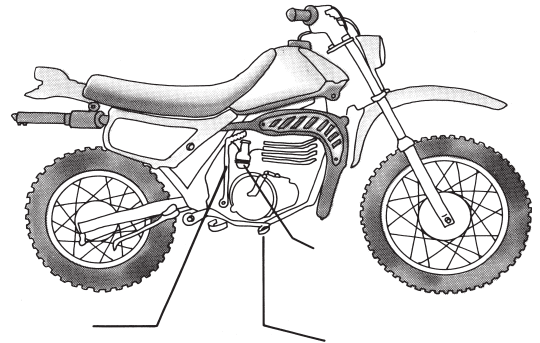
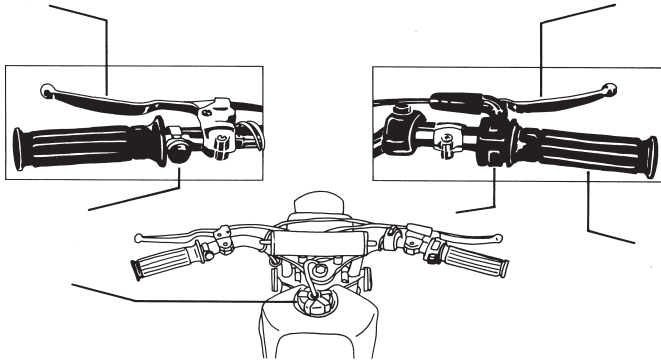

PART 2

LOCATING THE CONTROLS GAME

Now that you have shown your youngster the controls, it is your youngster's turn to show you. The engine remains OFF for this exercise and your youngster will be on the motorcycle. The youngster should be wearing the proper protective gear to develop this safety habit.

1. Have your youngster show you the location of the following:

- Brakes (lever and pedal)
- Throttle Control
- Engine Stop Switch
- Shift Lever (if equipped)
- Clutch (if equipped)

2. Have your youngster show you how the controls work. Be sure he or she understands the proper operation of each control. Skilled use of these controls should develop with practice. Under actual riding conditions the rider will have to watch ahead while operating the controls. Your youngster should be able to find the controls quickly without looking for them.
3. With your youngster looking ahead (pick out a point to look at), have him or her operate the controls. Repeat often while changing the order.
4. Ask your youngster to operate the controls as if actually riding. Look for smooth and precise operation.

PRE-RIDE CHECK

Before you continue:

1. Have you determined your youngster's readiness to ride an OHM? Do not let your youngster ride if you have any doubt. (Refer to the Readiness Checklist, Part 4)
2. Have you read the owner's manual and reviewed it with your youngster?
3. Does your youngster fit the motorcycle properly?
4. Have you inspected the vehicle and maintained it according to the owner's manual?
5. Is your youngster wearing the proper protective gear? Is the mounting procedure correct?
6. Has your youngster learned to locate the motorcycle controls without looking at them? Does he or she know how to operate them smoothly?
7. Does your youngster understand that he or she must always ride off-road?
8. Have you stressed to your youngster to keep his or her feet on the footpegs while riding?

If you have completely covered all these areas, you are ready to go on to Part 3.

PART 3

OPERATING PROCEDURES AND PRACTICE

Carefully observe your youngster's first use of the motorcycle. Observe his or her readiness to ride. Only permit your youngster to continue to ride if they have the size, strength, and attitude needed to ride safely.

Show your youngster the engine, exhaust pipe, and muffler. Tell him or her not to touch these parts because they are hot while the engine is running. Explain that they will remain hot after the engine is stopped. Also explain that hands and feet must be kept away from moving parts of the motorcycle.

Your youngster's safety depends in part on the mechanical condition of the motorcycle. Be sure to inspect it thoroughly before each use. Starting and refueling of the vehicle should be done by responsible adults only. Follow a regular maintenance program. See the owner's manual for inspection details.

Even after young riders have learned the basic riding skills, direct supervision by an experienced adult is necessary AT ALL TIMES. Make sure

that all off-highway motorcycle users under your supervision get proper riding instructions. Stress that an OHM is not a toy. Follow safety precautions strictly to provide a "safety first" approach to off-highway motorcycle riding. Teaching your youngster how to ride an OHM safely will increase the enjoyment of off-highway motorcycle riding.

Learning Area/Riding Area

The best place for learning is a level area 100' x 200' that is free from obstacles such as rocks, stumps, or holes. The learning area may have a loose or hard dirt surface. A grassy surface is also acceptable. It should not have two different surfaces. **Under no circumstances should the surface be concrete or asphalt.** Be sure there is room enough to maneuver, and that no other riders are close.

PART 3

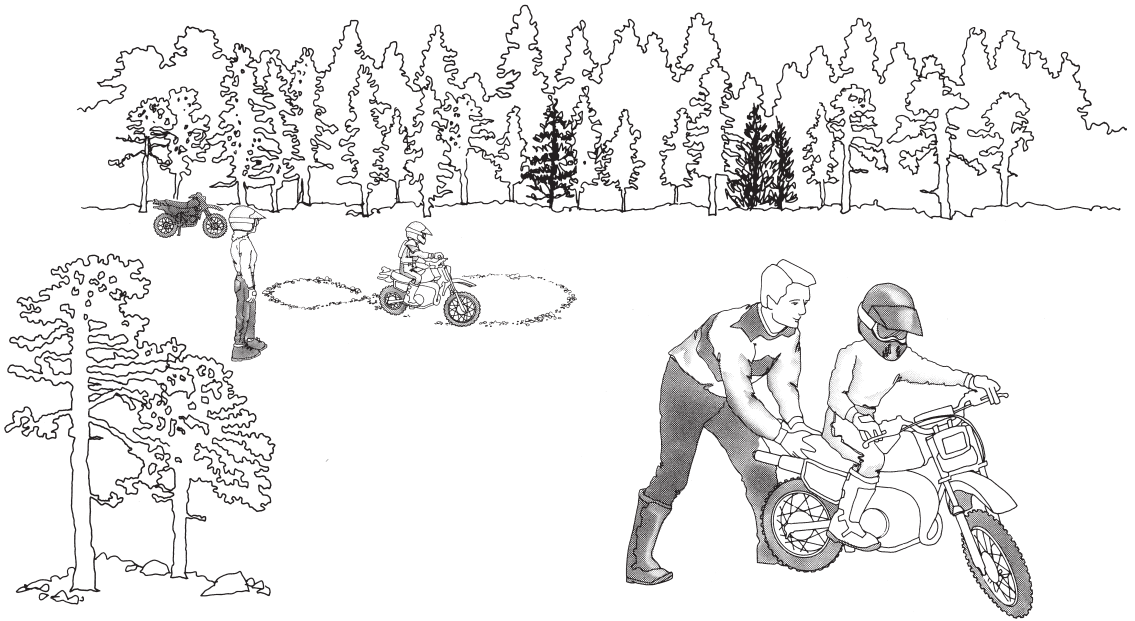

PART 3

Getting Used To The Vehicle In Motion

GETTING THE FEEL OF THE BRAKES

Be sure your youngster is wearing all of the proper protective gear. With the engine still OFF, have your youngster mount the motorcycle. If you physically can, push the motorcycle slowly. Have your youngster brake to feel how much pressure is needed for a smooth stop. If your youngster's motorcycle has more than one brake, both should be applied with even pressure. Practice this several times until you are sure this skill is developed. Remind your youngster to keep his or her head up and look forward.

GETTING THE FEEL OF THE THROTTLE

With the engine OFF, have your youngster practice smooth throttle control. Your youngster will learn how much throttle it takes to start moving in

a later exercise. Explain that opening the throttle will increase speed and that closing the throttle will decrease speed. Releasing the throttle and applying the brakes will slow the motorcycle. Ask your youngster to tell you how throttle control and braking affect the motorcycle's speed.

GETTING THE FEEL OF THE CLUTCH

(if equipped)

With the engine OFF, have your youngster practice smooth clutch control. Have your youngster shift the motorcycle into first gear. While you push the motorcycle have the youngster slowly release the clutch lever. The point which the motorcycle stops moving indicates the clutch engagement point or "friction zone." The "friction zone" is the point at which engine power begins to be transmitted to the rear wheel. Explain that this is the point the motorcycle will start moving when the engine is running. Smooth operation will prevent stalling and

allow smooth shifting. Remind the youngster that the throttle should be closed when shifting gears. Practice this exercise several times until the skill is developed.

GETTING THE FEEL OF TURNING

With the vehicle stopped and the engine OFF, have your youngster practice the proper turning technique:

1. For a right turn, look to the right and lean the motorcycle to the right.
2. For a left turn, look to the left and lean the motorcycle to the left.

Repeat this exercise with the kickstand up as you push the motorcycle. Make sure he or she can turn the vehicle in both directions using this technique while you maintain balance of the motorcycle.

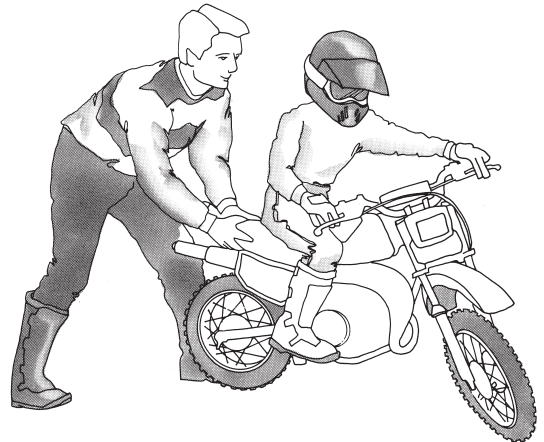

PART 3

BEING PREPARED FOR RIDING PRACTICE

Be sure to observe all the safety precautions covered in the Introduction and Parts 1 and 2. Double check that the riding area is free from hazards. Your youngster should wear all the proper protective gear, and the speed limiter (if equipped) should be installed and working correctly.

STARTING THE MOTORCYCLE

Always start the motorcycle for your youngster. To remember the proper starting technique use "FINE-C."

Double check for neutral. Start the engine. Have your youngster carefully mount. Let your youngster operate the engine stop switch and shut off the motor. Re-start the engine and repeat. Allow the engine to warm up until it runs smoothly with the choke off.

F	FUEL VALVE	Put to "on" position.
I	IGNITION	Ignition on.
N	NEUTRAL	Motorcycle in neutral (the motorcycle rolls with the clutch lever released).
E	ENGINE	Stop switch in run/on start position.
C	CHOKE	On (for cold engine only).

Let's Start Riding

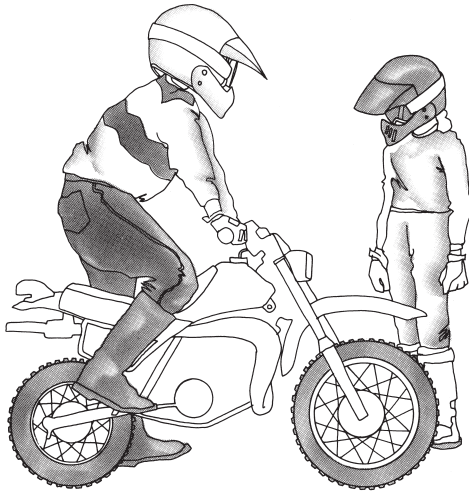

Start the motorcycle for your youngster

Walk next to the motorcycle when your youngster first starts riding. You can also let the beginner ride back and forth between you and another adult. Help your youngster with the turns as he or she practices throttle control and braking.

STARTING OUT AND STOPPING

Before your youngster moves the motorcycle under power, take a few moments to practice smooth clutch control. After shifting to first gear, have your youngster rock the motorcycle a few inches back and forth by moving the clutch in and out of the "friction zone." The clutch is not fully released while doing this. It is important that clutch operation is smooth before riding in the practice area.

The next practice session is straight-line starts and stops. Keep the riding under control.

PART 3

However, riding too slowly will make balance more difficult. Both brakes should be used together for smooth stops. The left foot should be placed on the ground first, keeping the right foot on the rear brake.

Be sure your youngster develops a good feel for the use of the throttle and controls. After the youngster has mastered starting and stopping at slower speeds, increase speeds by shifting.

TURNING

Remind your youngster of the two steps for turning:

1. For a right turn, look to the right and lean the motorcycle to the right.
2. For a left turn, look to the left and lean the motorcycle to the left.

Have your youngster practice turning in both directions at slow speeds. Allow enough room to make a wide turn. After your youngster is skilled in making wide turns, try tighter turns.

Keep speed slow.

Your youngster should master these skills at low speeds before going faster. Next, practice some figure eights. This will help your youngster make left and right turns. Make sure your youngster keeps both feet on the footpegs and looks ahead in the turns.

Once these skills are mastered, refer to the [Tips & Practice Guide for the Off-Highway Motorcyclist](#), for additional skills used in off-highway riding.

PART 3

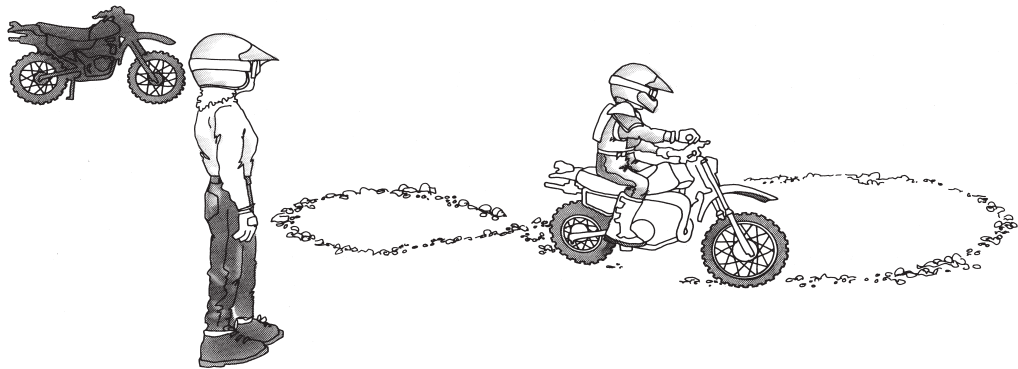

This Readiness Checklist is provided to help you determine your youngster's readiness to learn to safely operate and control an OHM. There is a significant amount of judgment needed in determining a youngster's readiness to ride an OHM. The ultimate decision is the responsibility of the parent, guardian, or supervising adult. It is important that parents make informed decisions about whether or not their youngster becomes involved in off-highway motorcycle activity.

There are four developmental areas considered in the Readiness Checklist. These include: visual perception/motor development, physical development, social/emotional development, and reasoning and decision-making ability. Several questions are listed to help you determine if your youngster possesses the skills and capabilities to safely learn to operate an OHM.

The best way to utilize the Readiness Checklist is to read the particular ability, consider the answers to the questions for that ability, and check those abilities that you determine are present in your youngster. There are no suggestions as to how many abilities or the degree of ability that your youngster should possess. This Readiness Checklist may help you consider the appropriateness of OHM operation for your child. The ultimate decision for your youngster's involvement with off-highway motorcycles belongs to you, the parent.

VISUAL PERCEPTION/MOTOR DEVELOPMENT

Ability

1. Youngster can see with sufficient clarity.
2. Youngster possesses ability to perceive depth or distance.
3. Youngster has adequate side vision/ peripheral vision.
4. Youngster can judge the speed of objects.



Points to Evaluate

- Can youngster see letters and numbers at least as well as you?
- Can youngster distinguish colors?
- Has youngster demonstrated adequate vision in other activities (riding bicycles, running, sports, or other recreational activities)?
- When looking at two objects in the distance, can youngster tell which is farther or closer?
- Can youngster see objects 90 degrees to each side while looking straight ahead?
- Does the youngster judge the speed of objects (fast, medium, slow) that agree with your judgments? (For example, a car on the highway, a train moving past a crossing, a dog running, people walking.)

PART 4

Ability

5. Youngster can state the distances of objects in terms of feet, yard, miles.
6. Youngster can follow movement of objects.
7. Youngster can visualize distances as displayed by a picture or photograph.
8. Youngster can follow a moving object while accomplishing hand manipulation.
9. Youngster can describe cause-and-effect experiences.



Points to Evaluate

- Can youngster tell how many feet or yards it is from the house to the road?
- Can youngster tell how wide a hallway is, or the width of a room?
- Can youngster follow the path of such things as: a hit or thrown baseball, a moving car, objects in a video game?
- Can youngster estimate distance between objects in a family photograph?
- Can youngster estimate distance between objects when looking at a landscape picture?
- Can youngster dribble a basketball without looking at it?
- Can youngster manipulate video game controls while following objects on a screen?
- Can youngster describe a minor injury he or she received and correctly describe the causes?
- Can youngster describe settings or situations that can produce injury if precautions are not taken?

Ability

10. Youngster can concentrate on more than one element at a time in solving a puzzle or problem.
11. Youngster can maintain relative spans of attention when given a variety of stimuli.



Points to Evaluate

- Can youngster describe what may cause injury when doing such things as running, swimming, bicycling, riding in a car?
- Can youngster pick out or describe several items within a picture?
- Can youngster assemble a puzzle without unusual problems or delays?
- Can youngster describe what to do if a house fire should occur?
- Can youngster complete school homework assignments without being easily distracted?
- Can youngster assemble more difficult puzzles; for example, a nature scene or picture?

PART 4

PHYSICAL DEVELOPMENT

Ability

1. Youngster can sit comfortably on the motorcycle and reach the controls easily.

2. Youngster has sufficient strength and familiarity to operate the controls with ease.



Points to Evaluate

- Can youngster place his or her feet firmly on the footpegs?
- Do the youngster's fingers reach comfortably around the handlebars and control levers? How about with the handlebars turned? How about in different seating positions?
- Can youngster stand (with knees slightly bent) and have a few inches of space from the seat?
- Can youngster easily reach the foot controls?
- Can youngster dress with proper protective gear including putting on helmet and fastening the chin strap?

While sitting on the vehicle, can youngster:

- Squeeze the hand controls?
- Operate the shift lever (if equipped)?
- Operate the choke and fuel valve with ease?
- Press the brake lever with sufficient pressure
- Operate the controls without looking at them?

Ability

3. Youngster is sufficiently coordinated.



Points to Evaluate

Can youngster walk a "balance beam" (2" x 4" x 8') flat on floor?

Can youngster ride a bicycle, rollerskate or skateboard safely?

Can youngster walk on tiptoes for 10 feet?

Can youngster jump rope?

Can youngster catch a ball with hands rather than with arms?

4. Youngster has sufficient endurance to maintain strength over a period of time.

Can youngster play outdoor games without fatigue?

Can youngster participate in indoor games and sports without tiring before other youngsters?

PART 4

SOCIAL/EMOTIONAL DEVELOPMENT

Ability	✓	Points to Evaluate
1. Youngster can understand and follow rules.	<input type="checkbox"/>	Does youngster follow rules established at home?
	<input type="checkbox"/>	Do teachers say that the youngster follows rules?
	<input type="checkbox"/>	Does youngster listen and respond to adult supervision?
	<input type="checkbox"/>	Does youngster comprehend the importance and seriousness of having rules and regulations?
2. Youngster generally will obey parents and supervisors.	<input type="checkbox"/>	Does youngster avoid challenging authority or rebelling when rules are imposed?
3. Youngster controls behavior according to expectations?	<input type="checkbox"/>	Does youngster show evidence of self-control...doesn't get easily frustrated or upset?
	<input type="checkbox"/>	Does youngster understand consequences associated with certain actions (like not wearing a safety belt in the car)?
	<input type="checkbox"/>	Does youngster think about results before performing some action (like crossing the street, hitting or throwing a ball)?

Ability

4. Youngster understands other youngsters may be permitted to do what he/she may not be allowed to.

5. Youngster can give reasons and/or solutions to problems seen in the environment.

6. Youngster can make decisions based on reality and not fantasy.



Points to Evaluate

- Does youngster recognize unsafe actions of other youngsters?
- Does youngster appreciate being safer than others?
- Does youngster accept rules that are more stringent than what other youngsters have to follow?

- Can youngster explain how land (or grass) gets worn?
- Can youngster explain how even small damage to land can take years to recover?
- Can youngster distinguish between untouched land and used land?

- Can youngster complete a task in a step-by-step fashion (assemble a toy, clean a room)?
- Does youngster comprehend real injury as opposed to “cartoon” injury?
- Does youngster respond with logical solutions when asked to solve a problem?

PART 4

REASONING AND DECISION-MAKING ABILITY

Ability

1. Youngster comprehends that interaction with others and things can result in injury.
2. Youngster has a basic understanding of what being careful means.



Points to Evaluate

- Can youngster describe how and why a person received physical injury or pain?
- Does youngster notice impending accidents or potential injury-producing events, such as in sports activities or bicycle riding?
- Can youngster explain why it takes distance to stop?
- Can youngster explain how moving at even low speed can result in injury if stopped suddenly or by hitting something?
- Does youngster know why rules are established?
- Does youngster notice or recognize others being careful in action-oriented activities?
- Does youngster notice professional athletes use protective gear as part of their sport?

Ability

3. Youngster understands that rules are made to reduce injury and provide long-term enjoyment.
4. Youngster has basic understanding of the physical limitations of stopping and turning.



Points to Evaluate

- Can youngster explain the reason for rules at home or school?
- Does youngster understand the value of prevention? Of wearing protective gear?
- Can youngster recognize that not following rules can eliminate future fun and enjoyment?
- Can youngster explain what may happen if moving too fast while going around a curve on a bicycle? On a skateboard? On an off-highway motorcycle?

FINAL NOTE

TO PARENTS

We hope this booklet has helped you and your youngster take a “safety first” approach to off-highway motorcycle riding. All off-highway motorcycle riders must use good judgment and be responsible. It is up to YOU to set a good example about motorcycle safety. You must help your youngster ride sensibly and safely at all times.

After your youngster has mastered the riding skills in this booklet and has matured to a higher level of skills, he or she may be ready to practice more advanced riding. The Motorcycle Safety Foundation’s *Tips & Practice Guide for the Off-Highway Motorcyclist* booklet provides information about riding on hills, riding across slopes, and other more advanced skills. Youngsters should have a good understanding of riding skills before using unfamiliar areas. They

should ride on flat areas, gentle hills, and gradual slopes. Be sure that your youngster rides slowly over unfamiliar terrain to locate and avoid bumps, holes, and other possible hazards. You should check the area first.

The Motorcycle Safety Foundation also recommends a video program, *The MSF DirtBike School: Learn to Ride Safely*. It demonstrates and discusses responsible riding practices.

It is also recommended that you and your youngster read the information in the owner’s manual. To find out more about rider education and off-highway motorcycle safety programs offered, or to order the video or publications, contact the **Motorcycle Safety Foundation at 2 Jenner, Suite 150, Irvine CA 92618, 949.727.3227 or visit dirtbikeschool.com**

BRAKES - The parts of a motorcycle which allow the operator to slow down or stop the machine.

BRAKE LEVER - The hand brake located on the handlebar.

BRAKE PEDAL - The foot brake which is operated by the right foot.

CABLES - Heavy insulated wires. There are two kinds: mechanical and electrical. Brake cables are mechanical. The headlamp cable is electrical.

CARBURETOR - Device which provides the engine the proper mixture of fuel and air.

CHOKE - A device which enriches the mixture of gasoline and air supplied to the engine for cold engine starting.

CLUTCH LEVER - The hand lever used to disengage the clutch when changing gears.

DRIVE CHAIN - The chain which connects the engine to the rear axle to give a motorcycle motion.

ENGINE STOP SWITCH - Switch used to stop the engine without removing the hands from the handlebars.

EXHAUST - Leftover gases from the combustion process that come out of the tailpipe when the motorcycle engine is running. Exhaust contains deadly carbon monoxide gases.

EYE PROTECTION - Goggles or a shatter resistant shield worn over the eyes while riding to protect against dust, flying insects, or other debris. Such eye protection, when tinted, may be effective against bright sun or snow-glare conditions.

FINE-C - A pre-start routine. A way to remember the pre-start routine:

F - Fuel valve on

I - Ignition on

N - Neutral

E - Engine stop switch in run position

C - Choke

FOOTPEGS - Pivoting pegs on which a motorcycle operator should keep his/her feet while riding.

FUEL VALVE - A valve, usually hand operated, with an on, off and "reserve" position. Controls gasoline flow to the carburetor.

GLOSSARY

HANDLEBAR - The metal bar attached to the front end of the motorcycle that turns the front wheel for steering. Many of the controls for the motorcycle are located on the handlebar.

HELMET - The most important protective clothing to be worn when operating a motorcycle. It covers the head and helps protect against skull fracture or brain injury in an accident.

OFF-HIGHWAY or OFF-ROAD VEHICLE - Any vehicle, including off-highway motorcycles and ATVs, which is restricted by law from operating on public roads.

OHM - Off-Highway Motorcycle

PSI - Refers to air pressure in the tires and stands for "Pounds per Square Inch."

READING THE TERRAIN - Looking well ahead while riding, anticipating hazards.

SHIFT LEVER - On those motorcycles equipped with a shift lever, it allows the operator to change gears. The shift lever is operated by the left foot.

TAILPIPE - That part of the exhaust system which expels waste gases.

THROTTLE - The control operated by the right hand which controls the engine speed.

TRACTION - Tread friction between the ground and the tires.

TRANSMISSION - Mechanism used to transmit power from the engine to the wheels.

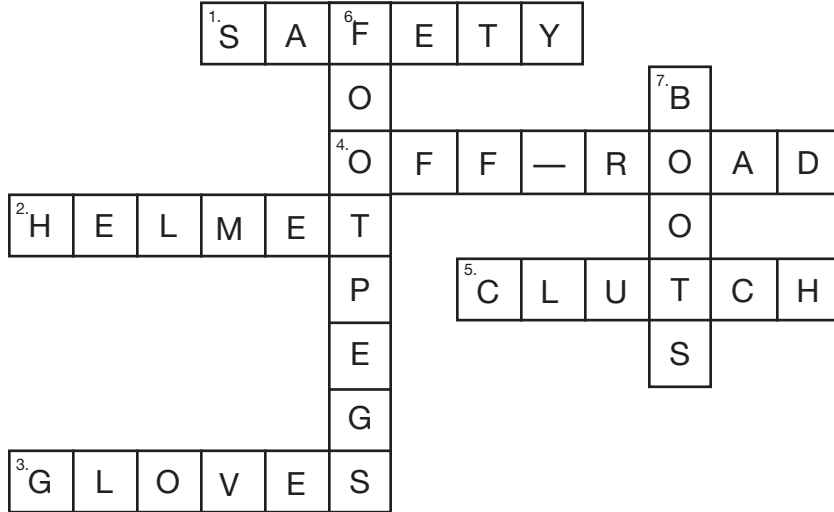

ANSWERS

NAME THE MOTORCYCLE PARTS (Typical)

1. Clutch lever
2. Hand brake lever
3. Foot brake lever or pedal
4. Throttle
5. Choke or enrichening device
6. Engine stop switch
7. Gas cap/tank vent
8. Starter (kick)
9. Electric starter (if equipped)

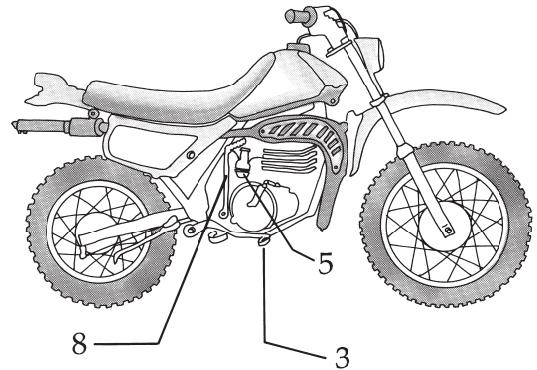
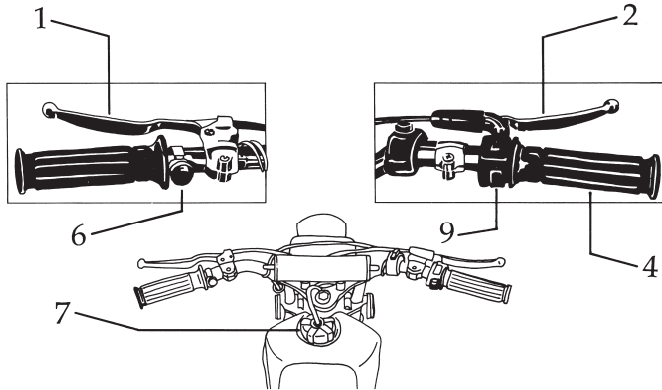

NOTES

NOTES



**For the rider training location nearest you,
call: (877) 288-7093**

dirtbikeschool.com

© 2015 Motorcycle Safety Foundation, Inc.
2 Jenner, Suite 150 • Irvine, CA 92618
(949) 727-3227 • msf-usa.org

PN MSPU3444NC00

A		Customer service	10
Accessories	10	D	
Accident	8	Diagnostics connector	18
Air suspension	30	E	
Article number		Engine	
fork	14	work	8
shock absorber	15	Engine number	14
Auxiliary substances	10	Environment	8
B		F	
Basic chassis setting		Fall	8
rider's weight, checking with	30	Figures	10
Battery charger		Fire hazard	9
overview	88	Foot brake lever	18
positioning	88	free travel, adjusting	73
Brake discs		Fork	
checking	66	article number	14
Brake fluid		Fork article number	14
front brake, adding	68	Fork legs	
rear brake, adding	75	air pressure, adjusting	37
Brake fluid level		basic setting, checking	37
of front brake, checking	67	bleeding	46
of rear brake, checking	74	dust boots, cleaning	47
Brake lever		installing	49
front wheel	16	removing	48
rear wheel	17	Fork protector	
Brake lining retainers		installing	48
of front brake, checking	69	removing	48
of rear brake, checking	77	Frame	
Brake linings		checking	64
of front brake, changing	70	Frame label	14
of front brake, checking	69	Front brake lever	16
of rear brake, checking	77	basic position, adjusting	66
of the rear brake, changing	77	checking play	66
C		Front fender	
Care	94-95	installing	56
Chain		removing	56
checking	61	Front wheel	
cleaning	59	installing	82
Chain guide		removing	82
adjusting	64	Fuel, oils, etc.	10
checking	61	H	
Chain tension		Handlebar position	39
adjusting	61	adjusting	39
checking	60	High-speed compression damping	
Charging	89	shock absorber, adjusting	32
Charging level indicator	20	I	
Cleaning	94-95	Implied warranty	10
Cooling	93		

Intended use	6	Rear sprocket	
L		checking	61
Link fork		Rear wheel	
checking	64	installing	84
Lower triple clamp		removing	83
installing	51	Rebound damping	
removing	50	fork, adjusting	38
Low-speed compression damping		shock absorber, adjusting	32
shock absorber, adjusting	31	Rechargeable lithium-ion battery	
LV traction battery		battery identification number (BIN)	15
battery identification number (BIN)	15	charging	89
charging	89	work	8
work	8	Recuperation	26
M		Ride mode button	19
Magnetic switch		Ride mode display	20
on handlebar	16	Riding sag	
under the seat	17	adjusting	35
Malfunction indicator lamp	20	Rubber grip	
Manufacturer warranty	10	checking	64
Misuse	6	S	
Motor sprocket		Safe operation	7
checking	61	Seat	
Motorcycle		mounting	59
cleaning	94	removing	58
lift stand, raising with	46	Seat height	
lift stand, removing from	46	adjusting on the fork	42
Multifunctional element	19	adjusting on the frame	43
Overview	19	adjusting on the shock absorber	41
O		adjustment options	41
On/Off button	16	Service	10
Operation		Service schedule	28-29
at low temperatures	11	Shock absorber	
Owner's Manual	9	article number	15
P		installing	57
Plug-in stand	18	removing	57
Power reduction	21	riding sag, checking	34
Power supply	11	rubber buffer and pivot points, checking	58
Preparing for use		spring preload, adjusting	34
advice on preparing for first use	22	static sag, checking	33
after storage	96	Shock absorber article number	15
checks and maintenance measures when	24	Spare parts	10
preparing for use	24	Spoke tension	
Protective clothing	8	checking	86
R		Start number plate	
Rear brake lever	17	installing	55
basic position, adjusting	73	removing	55
free travel, checking	72	Starting	24
		Steering head bearing	
		lubricating	55

Steering head bearing play	
adjusting	54
checking	53
Storage	96
T	
Technical specifications	
chassis	100
chassis tightening torques	103
electrical system	101
engine	99
fork	101
shock absorber	102
tires	101
Throttle grip	16
Tire condition	
checking	85
Tire pressure	
checking	86
Transportation	27
Troubleshooting	97-98
U	
Use definition	6
V	
Vehicle	
work	8
Vehicle identification number	14
View of vehicle	
front left	12
rear right	13



3214831en

29.01.2024

