



OWNER'S MANUAL 2022

MC 250

Art. no. 3215074en



GASGAS

Congratulations on your decision to purchase a GASGAS motorcycle. You are now the owner of a state-of-the-art sports vehicle which, with appropriate care, will bring you pleasure for a long time to come.

We wish you good and safe riding at all times!

Enter the serial numbers of your vehicle below.

Vehicle identification number (📖 p. 12)	Dealer's stamp
Engine number (📖 p. 12)	

The Owner's Manual contained the latest information for this model series at the time of publication. However, minor differences due to further developments in design cannot be ruled out completely.

All specifications contained herein are non-binding. GASGAS Motorcycles GmbH specifically reserves the right to modify or delete technical specifications, prices, colors, forms, materials, services, designs, equipment, etc., without prior notice and without specifying reasons, to adapt these to local conditions, as well as to stop production of a particular model without prior notice. GASGAS Motorcycles accepts no liability for delivery options, deviations from figures and descriptions, as well as misprints and other errors. The models portrayed partly contain special equipment that does not belong to the regular scope of supply.

© 2021 GASGAS Motorcycles GmbH, Mattighofen Austria

All rights reserved

Reproduction, even in part, as well as copying of all kinds, is permitted only with the express written permission of the copyright owner.



ISO 9001(12 100 6061)

GASGAS Motorcycles applies quality assurance processes that lead to the highest possible product quality as defined in the ISO 9001 international quality management standard.

Issued by: TÜV Management Service

REG.NO. 12 100 6061

GASGAS Motorcycles GmbH

Stallhofnerstraße 3



5230 Mattighofen, Austria

This document is valid for the following models:

MC 250 (F0301V0)



TABLE OF CONTENTS

1	MEANS OF REPRESENTATION	5	7.5	Preparing the vehicle for rides on wet sand	21
1.1	Symbols used.....	5	7.6	Preparing the vehicle for rides on wet and muddy circuits.....	22
1.2	Formats used.....	5	7.7	Preparing vehicle for high temperatures or slow riding.....	23
2	SAFETY ADVICE	6	7.8	Preparing the vehicle for low temperatures or snow	24
2.1	Use definition – intended use.....	6	8	RIDING INSTRUCTIONS.....	25
2.2	Misuse.....	6	8.1	Checks and maintenance measures when preparing for use.....	25
2.3	Safety advice.....	6	8.2	Starting	25
2.4	Degrees of risk and symbols	6	8.3	Starting off.....	26
2.5	Tampering warning	7	8.4	Shifting, riding	26
2.6	Safe operation	7	8.5	Applying the brakes.....	27
2.7	Protective clothing	7	8.6	Stopping, parking.....	27
2.8	Work rules	8	8.7	Transporting	28
2.9	Environment.....	8	8.8	Refueling.....	28
2.10	Owner's Manual	8	9	SERVICE SCHEDULE.....	30
3	IMPORTANT NOTES	9	9.1	Additional information	30
3.1	Manufacturer warranty, implied warranty	9	9.2	Required work	30
3.2	Fuel, auxiliary substances.....	9	9.3	Recommended work.....	31
3.3	Spare parts, accessories	9	10	TUNING THE CHASSIS	32
3.4	Service	9	10.1	Checking the basic chassis setting with the rider's weight	32
3.5	Figures	9	10.2	Air suspension XACT 5448.....	32
3.6	Customer service.....	9	10.3	Compression damping of the shock absorber	33
4	VIEW OF VEHICLE	10	10.4	Adjusting the low-speed compression damping of the shock absorber	33
4.1	View of vehicle, front left (example)	10	10.5	Adjusting the high-speed compression damping of the shock absorber	33
4.2	View of vehicle, rear right (example).....	11	10.6	Adjusting the rebound damping of the shock absorber	34
5	SERIAL NUMBERS.....	12	10.7	Measuring the rear wheel dimension unloaded.....	34
5.1	Vehicle identification number.....	12	10.8	Checking the static sag of the shock absorber	35
5.2	Type label	12	10.9	Checking the riding sag of the shock absorber	36
5.3	Engine number.....	12	10.10	Adjusting the spring preload of the shock absorber 	36
5.4	Fork part number	12	10.11	Adjusting the riding sag 	37
5.5	Shock absorber article number.....	13	10.12	Checking the basic setting of the fork	38
6	CONTROLS.....	14	10.13	Adjusting the fork air pressure.....	38
6.1	Clutch lever.....	14	10.14	Adjusting the compression damping of the fork	39
6.2	Hand brake lever	14	10.15	Adjusting the rebound damping of the fork.....	40
6.3	Throttle grip.....	14	10.16	Handlebar position.....	40
6.4	Stop button.....	14	10.17	Adjusting the handlebar position 	40
6.5	Opening the fuel tank filler cap.....	15	11	SERVICE WORK ON THE CHASSIS	42
6.6	Closing the fuel tank filler cap.....	15	11.1	Raising the motorcycle with a lift stand	42
6.7	Fuel tap.....	16	11.2	Removing the motorcycle from the lift stand	42
6.8	Choke	16			
6.9	Shift lever.....	16			
6.10	Kick starter lever.....	17			
6.11	Foot brake lever	17			
6.12	Plug-in stand.....	17			
7	PREPARING FOR USE	18			
7.1	Advice on preparing for first use	18			
7.2	Running in the engine	19			
7.3	Preparing the vehicle for difficult operating conditions	19			
7.4	Preparing the vehicle for rides on dry sand	20			

11.3	Bleeding the fork legs.....	42	12.7	Changing the brake linings of the front brake 🛠️.....	74
11.4	Cleaning the dust boots of the fork legs.....	43	12.8	Checking the free travel of foot brake lever	76
11.5	Removing the fork legs 🛠️.....	43	12.9	Adjusting the basic position of the foot brake lever 🛠️.....	77
11.6	Installing the fork legs 🛠️.....	44	12.10	Checking the rear brake fluid level	77
11.7	Removing the fork protector	45	12.11	Adding rear brake fluid 🛠️.....	78
11.8	Installing the fork protector	45	12.12	Checking the brake linings of the rear brake	79
11.9	Removing the lower triple clamp 🛠️.....	45	12.13	Changing the rear brake linings 🛠️.....	79
11.10	Installing the lower triple clamp 🛠️.....	46	13	WHEELS, TIRES.....	82
11.11	Checking steering head bearing play.....	48	13.1	Removing the front wheel 🛠️.....	82
11.12	Adjusting steering head bearing play 🛠️.....	48	13.2	Installing the front wheel 🛠️.....	83
11.13	Lubricating the steering head bearing 🛠️.....	49	13.3	Removing the rear wheel 🛠️.....	83
11.14	Removing the start number plate.....	49	13.4	Installing the rear wheel 🛠️.....	84
11.15	Installing the start number plate	49	13.5	Checking the tire condition.....	86
11.16	Removing front fender.....	50	13.6	Checking tire pressure.....	86
11.17	Installing front fender	50	13.7	Checking spoke tension.....	87
11.18	Removing the shock absorber 🛠️.....	50	14	COOLING SYSTEM	88
11.19	Installing the shock absorber 🛠️.....	52	14.1	Cooling system	88
11.20	Removing the seat.....	53	14.2	Checking the antifreeze and coolant level.....	88
11.21	Mounting the seat.....	54	14.3	Checking the coolant level.....	89
11.22	Removing the air filter box cover.....	54	14.4	Draining the coolant 🛠️.....	89
11.23	Installing the air filter box cover	55	14.5	Refilling with coolant 🛠️.....	90
11.24	Removing the air filter 🛠️.....	56	14.6	Changing the coolant 🛠️.....	92
11.25	Cleaning the air filter and air filter box 🛠️.....	56	15	TUNING THE ENGINE	94
11.26	Installing the air filter 🛠️.....	57	15.1	Checking the play in the throttle cable.....	94
11.27	Preparing air filter box cover for securing 🛠️.....	57	15.2	Adjusting the play in the throttle cable 🛠️.....	94
11.28	Removing the main silencer.....	58	15.3	Carburetor tuning.....	95
11.29	Installing the main silencer	58	15.4	Carburetor – idle setting.....	97
11.30	Changing the glass fiber yarn filling in the main silencer 🛠️.....	58	15.5	Carburetor – adjusting the idle speed 🛠️.....	98
11.31	Removing the fuel tank 🛠️.....	59	15.6	Plug-in connector of ignition timing map adjustment	99
11.32	Installing the fuel tank 🛠️.....	60	15.7	Changing the ignition timing map.....	99
11.33	Checking the chain for dirt.....	61	15.8	Checking the basic position of the shift lever	99
11.34	Cleaning the chain.....	62	15.9	Adjusting the basic position of the shift lever 🛠️.....	99
11.35	Checking the chain tension	62	15.10	Engine characteristic – adjusting the auxiliary spring 🛠️.....	100
11.36	Adjusting the chain tension	63	16	SERVICE WORK ON THE ENGINE	102
11.37	Checking the chain, rear sprocket, engine sprocket, and chain guide	64	16.1	Emptying the carburetor float chamber 🛠️.....	102
11.38	Checking the frame 🛠️.....	66	16.2	Checking the gear oil level	103
11.39	Checking the link fork 🛠️.....	66	16.3	Changing the gear oil 🛠️.....	103
11.40	Checking the throttle cable routing.....	66	16.4	Adding the gear oil 🛠️.....	104
11.41	Checking the rubber grip	67	17	CLEANING, CARE.....	106
11.42	Adjusting the basic position of the clutch lever.....	68	17.1	Cleaning the motorcycle	106
11.43	Checking/correcting the fluid level of the hydraulic clutch	68			
11.44	Changing the hydraulic clutch fluid 🛠️.....	69			
12	BRAKE SYSTEM.....	71			
12.1	Checking the free travel of the hand brake lever.....	71			
12.2	Adjusting the basic position of the hand brake lever.....	71			
12.3	Checking the brake discs.....	71			
12.4	Checking the front brake fluid level.....	72			
12.5	Adding front brake fluid 🛠️.....	72			
12.6	Checking the front brake linings	74			

TABLE OF CONTENTS

18	STORAGE.....	108
18.1	Storage.....	108
18.2	Preparing for use after storage.....	109
19	TROUBLESHOOTING	110
20	TECHNICAL DATA.....	112
20.1	Engine	112
20.2	Engine tightening torques.....	112
20.3	Carburetor	114
20.3.1	Carburetor tuning	114
20.3.2	Basic carburetor setting for sandy surfaces	115
20.4	Capacities.....	115
20.4.1	Gear oil	115
20.4.2	Coolant	115
20.4.3	Fuel	115
20.5	Chassis	115
20.6	Tires	116
20.7	Fork.....	116
20.8	Shock absorber.....	117
20.9	Chassis tightening torques	117
21	SUBSTANCES.....	120
22	AUXILIARY SUBSTANCES.....	122
23	STANDARDS	124
24	LIST OF ABBREVIATIONS.....	125
	INDEX	126

1.1 Symbols used

The meaning of specific symbols is described below.



Indicates an expected reaction (e.g., of a work step or a function).



Indicates an unexpected reaction (e.g., of a work step or a function).



All work marked with this symbol requires specialist knowledge and technical understanding. In the interest of your own safety, have this work performed by an authorized GASGAS Motorcycles workshop. Your motorcycle will be cared for there to the highest degree by specially trained experts using the special tools required.



Indicates a page reference (more information is provided on the specified page).



Indicates information with more details or tips.



Indicates the result of a testing step.



Indicates a voltage measurement.



Indicates a current measurement.



Indicates the end of an activity, including potential reworking.

1.2 Formats used

The typographical formats used in this document are explained below.

Proprietary name	Indicates a proprietary name.
Name[®]	Indicates a protected name.
Brand[™]	Indicates a brand available on the open market.
<u>Underlined terms</u>	Refer to technical details of the vehicle or indicate technical terms, which are explained in the glossary.

2.1 Use definition – intended use

This vehicle has been designed and built to withstand the normal stresses and strains of racing. This vehicle complies with the currently valid regulations and categories of the top international motorsports organizations.



Info

Only operate this vehicle in closed-off areas remote from public road traffic.

2.2 Misuse

The vehicle must only be used as intended.

Dangers can arise for people, property and the environment through use not as intended.

Any use of the vehicle beyond the intended and defined use constitutes misuse.

Misuse also includes the use of operating and auxiliary fluids which do not meet the required specification for the respective use.

2.3 Safety advice

A number of safety instructions need to be followed to operate the product described safely. Therefore read this instruction and all further instructions included carefully. The safety instructions are highlighted in the text and are referred to at the relevant passages.



Info

Various information and warning labels are attached in prominent locations on the product described. Do not remove any information or warning labels. If they are missing, you or others may not recognize dangers and may therefore be injured.

2.4 Degrees of risk and symbols



Danger

Identifies a danger that will immediately and invariably lead to fatal or serious permanent injury if the appropriate measures are not taken.



Warning

Identifies a danger that is likely to lead to fatal or serious injury if the appropriate measures are not taken.



Caution

Identifies a danger that may lead to minor injuries if the appropriate measures are not taken.

Note

Identifies a danger that will lead to considerable machine and material damage if the appropriate measures are not taken.



Note

Indicates a danger that will lead to environmental damage if the appropriate measures are not taken.

2.5 Tampering warning

Tampering with the noise control system is prohibited. Federal law prohibits the following acts or the causing thereof:

- 1 The removal or rendering inoperative by any person other than for purposes of servicing, repair, or replacement, of any device or element of design incorporated into any new vehicle for the purpose of noise control prior to its sale or delivery to the ultimate purchaser or while it is in use, or
- 2 the use of the vehicle after such device or element of design has been removed or rendered inoperative by any person.

Among those acts presumed to constitute tampering are the acts listed below:

- 1 Removal or puncturing of the main silencers, baffles, header pipes or any other components which conduct exhaust gases.
- 2 Removal or puncturing of parts of the intake system.
- 3 Lack of proper maintenance.
- 4 Replacing moving parts of the vehicle, or parts of the exhaust system or intake system, with parts other than those specified by the manufacturer.

2.6 Safe operation



Danger

Danger of accidents A rider who is not fit to ride poses a danger to him or herself and others.

- Do not operate the vehicle if you are not fit to ride due to alcohol, drugs or medication.
- Do not operate the vehicle if you are physically or mentally impaired.



Danger

Danger of poisoning Exhaust gases are toxic and inhaling them may result in unconsciousness and death.

- Always make sure there is sufficient ventilation when running the engine.
- Use effective exhaust extraction when starting or running the engine in an enclosed space.



Warning

Danger of burns Some vehicle components become very hot when the vehicle is operated.

- Do not touch any parts such as the exhaust system, radiator, engine, shock absorber, or brake system before the vehicle parts have cooled down.
- Let the vehicle parts cool down before you perform any work on the vehicle.

Only operate the vehicle when it is in perfect technical condition, in accordance with its intended use, and in a safe and environmentally compatible manner.

The vehicle should only be used by trained persons.

Have malfunctions that impair safety immediately eliminated by an authorized GASGAS Motorcycles workshop.

Adhere to the information and warning labels on the vehicle.

2.7 Protective clothing



Warning

Risk of injury Missing or poor protective clothing presents an increased safety risk.

- Wear appropriate protective clothing such as helmet, boots, gloves as well as trousers and a jacket with protectors on all rides.
- Always wear protective clothing that is in good condition and meets the legal regulations.

In the interest of your own safety, GASGAS Motorcycles recommends that you only operate the vehicle while wearing protective clothing.

2.8 Work rules

Unless specified otherwise, the ignition must be turned off during all work (models with ignition lock, models with remote key) or the engine must be at a standstill (models without ignition lock or remote key).

Special tools are necessary for certain tasks. The tools are not a component of the vehicle, but can be ordered using the number in parentheses. Example: bearing puller (15112017000)

Unless otherwise noted, normal conditions apply to all tasks and descriptions.

Ambient temperature	20 °C (68 °F)
Ambient air pressure	1,013 mbar (14.69 psi)
Relative air humidity	60 ± 5 %

During assembly, use new parts to replace parts which cannot be reused (e.g. self-locking screws and nuts, expansion screws, seals, sealing rings, O-rings, pins, and lock washers).

In the case of certain screws, a screw adhesive (e.g. **Loctite**®) is required. Observe the manufacturer's instructions.

If thread locker (e.g., **Precote**®) has already been applied to a new part, do not apply any additional thread locker.

After disassembly, clean the parts that are to be reused and check them for damage and wear. Change damaged or worn parts.

After completing a repair or service work, check the operating safety of the vehicle.

2.9 Environment

If you use your motorcycle responsibly, you can ensure that problems and conflicts do not occur. To protect the future of the motorcycle sport, make sure that you use your motorcycle legally, be environmentally aware, and respect the rights of others.

When disposing of used oil, other operating and auxiliary fluids, and used components, comply with the laws and regulations of the respective country.

Because motorcycles are not subject to the EU regulations governing the disposal of used vehicles, there are no legal regulations that pertain to the disposal of an end-of-life motorcycle. Your authorized GASGAS Motorcycles dealer will be glad to advise you.

2.10 Owner's Manual

Read this owner's manual carefully and completely before making your first trip. The Owner's Manual contains useful information and many tips on how to operate, handle, and service your motorcycle. This is the only way to find out how best to customize the vehicle for your own use and how you can protect yourself from injury.



Tip

Store the Owner's Manual on your terminal device, for example, so that you can read it whenever you need to.

If you would like to know more about the vehicle or have questions on the material you read, please contact an authorized GASGAS Motorcycles dealer.

The Owner's Manual is an important component of the vehicle. If the vehicle is sold, the Owner's Manual must be downloaded again by the new owner.

The Owner's Manual can be downloaded several times using the QR code or the link on the delivery certificate.

The Owner's Manual is available for download from your authorized GASGAS Motorcycles dealer and on the GASGAS Motorcycles website. A printed copy can also be ordered from your authorized GASGAS Motorcycles dealer. International GASGAS Motorcycles website: <http://www.gasgas.com>

3.1 Manufacturer warranty, implied warranty

The work specified in the service schedule may only be carried out in an authorized GASGAS Motorcycles workshop and confirmed in the **GASGAS Motorcycles Dealer.net**, as otherwise all warranty claims will be void. Damage or secondary damage caused by tampering with and/or conversions on the vehicle are not covered by the manufacturer warranty.

3.2 Fuel, auxiliary substances



Note

Environmental hazard Improper handling of fuel is a danger to the environment.

- Do not allow fuel to enter the groundwater, the soil, or the sewage system.

Use fuels and auxiliary substances in accordance with the Owner's Manual and specification.

3.3 Spare parts, accessories

For your own safety, only use spare parts and accessory products that are approved and/or recommended by GASGAS Motorcycles and have them installed by an authorized GASGAS Motorcycles workshop. GASGAS Motorcycles accepts no liability for other products and any resulting damage or loss. Certain spare parts and accessory products are specified in parentheses in the descriptions. Your authorized GASGAS Motorcycles dealer will be glad to advise you.

The latest news **GASGAS Technical Accessories** on your vehicle can be found on the GASGAS Motorcycles website. International GASGAS Motorcycles website: <http://www.gasgas.com>

3.4 Service

A prerequisite for perfect operation and prevention of premature wear is that the service, care, and tuning work on the engine and chassis is properly carried out as described in the Owner's Manual. An incorrect suspension setting can lead to damage and breakage of chassis components.

Use of the vehicle under difficult conditions, such as on sand or on wet, dusty and muddy surfaces, can result in significantly increased wear of components, such as the drive train, brake system, air filter or suspension components. For this reason, it may be necessary to inspect or replace parts before the next scheduled service.

It is imperative that you adhere to the stipulated run-in times and service intervals. If you observe these exactly, you will ensure a much longer service life for your motorcycle.

The relevant mileage or time interval is whichever occurs first.

3.5 Figures

The figures contained in the manual may depict special equipment.

In the interest of clarity, some components may be shown disassembled or may not be shown at all. It is not always necessary to disassemble the component to perform the activity in question. Please follow the instructions in the text.

3.6 Customer service

Your authorized GASGAS Motorcycles dealer will be happy to answer any questions you may have regarding your vehicle and GASGAS Motorcycles.

A list of authorized GASGAS Motorcycles dealers can be found on the GASGAS Motorcycles website. International GASGAS Motorcycles website: <http://www.gasgas.com>

4 VIEW OF VEHICLE

4.1 View of vehicle, front left (example)



V02471-10

- ① Hand brake lever (📖 p. 14)
- ② Clutch lever (📖 p. 14)
- ③ Air filter box cover
- ④ Plug-in stand (📖 p. 17)
- ⑤ Shift lever (📖 p. 16)
- ⑥ Choke (📖 p. 16)
- ⑦ Fuel tap

4.2 View of vehicle, rear right (example)



V02470-10

- ① Seat
- ② Fuel tank filler cap
- ③ Stop button (📖 p. 14)
- ④ Throttle grip (📖 p. 14)
- ⑤ Kick starter lever (📖 p. 17)
- ⑥ Foot brake lever (📖 p. 17)
- ⑦ Shock absorber compression adjuster
- ⑧ Shock absorber rebound adjuster
- ⑨ Level viewer for brake fluid, rear

5 SERIAL NUMBERS

5.1 Vehicle identification number

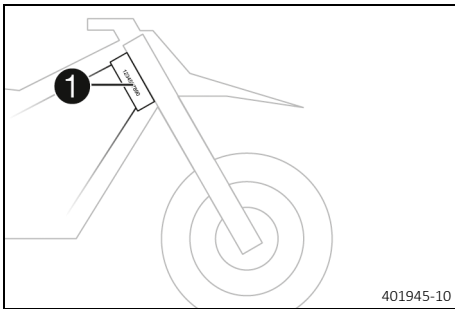

The vehicle identification number **1** is stamped on the right side of the steering head.

5.2 Type label

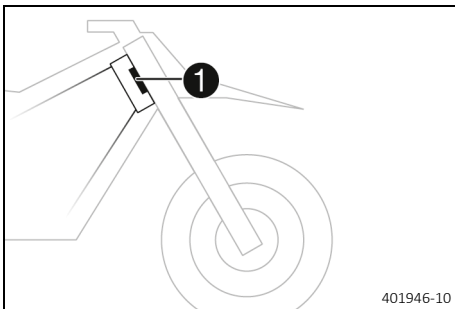

The type label **1** is fixed to the front of the steering head.

5.3 Engine number

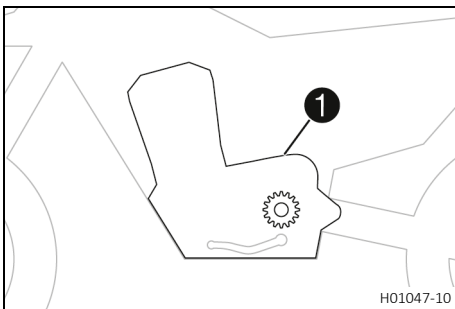

Engine number **1** is embossed on the left side of the engine above the engine sprocket.

5.4 Fork part number

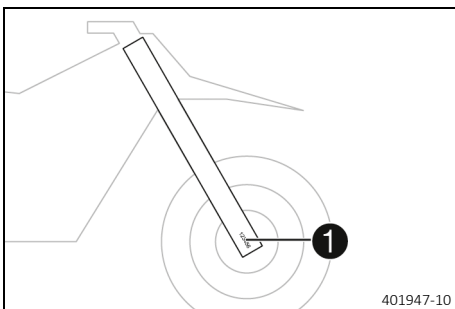

The fork part number **1** is stamped on the inside of the axle clamp.

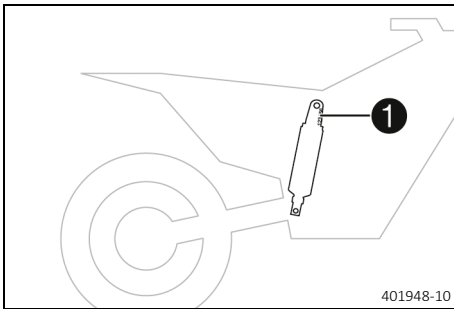
5.5 Shock absorber article number

Shock absorber article number **1** is stamped on the top of the shock absorber above the adjusting ring towards the engine side.

401948-10

6.1 Clutch lever

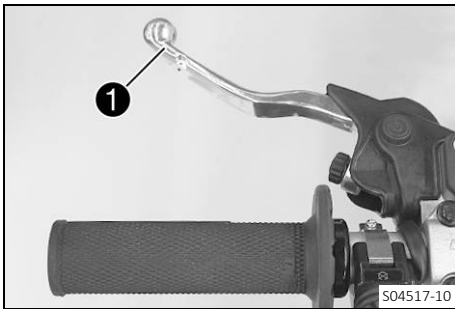

Clutch lever **1** is fitted on the handlebar on the left.
The clutch is activated hydraulically and adjusts itself automatically.

6.2 Hand brake lever

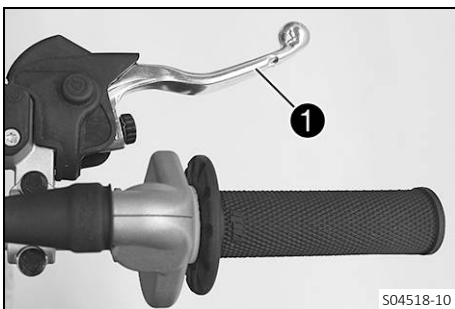

Hand brake lever **1** is fitted on the right side of the handlebar.
The front brake is engaged using the hand brake lever.

6.3 Throttle grip

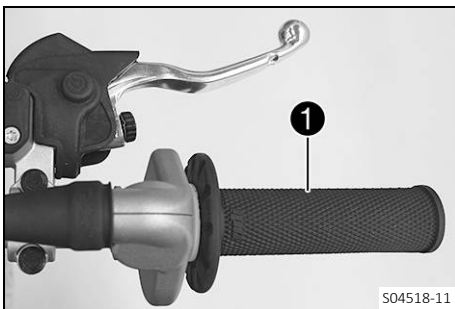

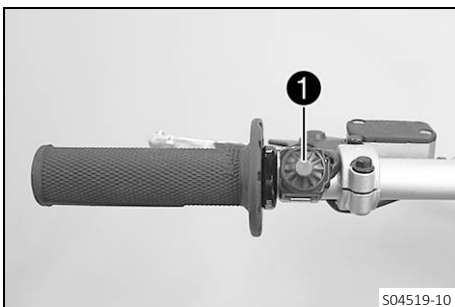

Throttle grip **1** is fitted on the right side of the handlebar.

6.4 Stop button



The stop button **1** is fitted on the left side of the handlebar.

Possible states

- The stop button  is in the basic position – In this position, the ignition circuit is closed and the engine can be started.
- Stop button  pressed – In this position, the ignition circuit is interrupted, a running engine stops, and a non-running engine will not start.

6.5 Opening the fuel tank filler cap



Danger

Fire hazard Fuel is highly flammable.

The fuel in the fuel tank expands when warm and can escape if overfilled.

- Do not fuel the vehicle in the vicinity of open flames or lit cigarettes.
- Switch off the engine for refueling.
- Make sure that no fuel is spilled; particularly not on hot parts of the vehicle.
- If any fuel is spilled, wipe it off immediately.
- Observe the specifications for refueling.



Warning

Danger of poisoning Fuel is poisonous and a health hazard.

- Avoid skin, eye and clothing contact with fuel.
- Immediately consult a doctor if you swallow fuel.
- Do not inhale fuel vapors.
- In case of skin contact, rinse the affected area with plenty of water.
- Rinse the eyes thoroughly with water, and consult a doctor in case of fuel contact with the eyes.
- Change your clothing in case of fuel spills on them.
- Keep fuels correctly in a suitable canister, and out of the reach of children.



Note

Environmental hazard Improper handling of fuel is a danger to the environment.

- Do not allow fuel to enter the groundwater, the soil, or the sewage system.

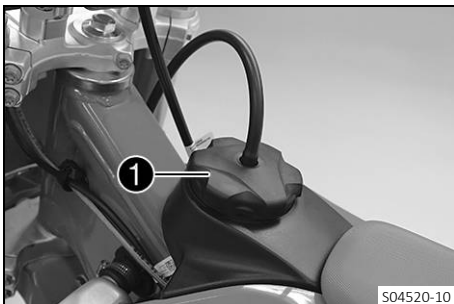

- Turn fuel tank filler cap ① counterclockwise and lift it off.

6.6 Closing the fuel tank filler cap

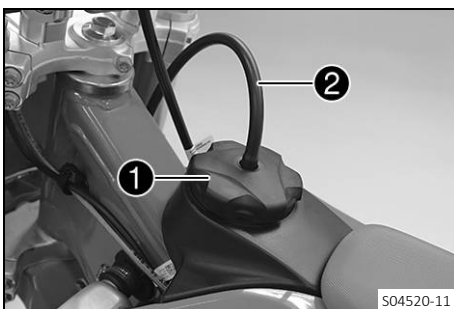

- Mount fuel tank filler cap ① and turn it clockwise until the fuel tank is tightly closed.



Info

Route fuel tank breather hose ② without kinks.

6.7 Fuel tap

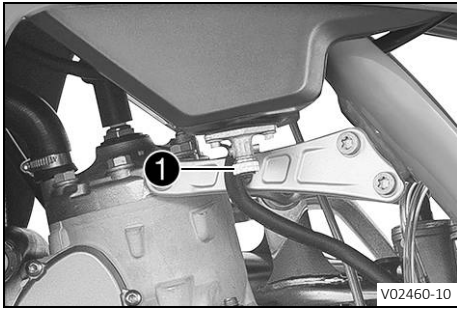

The fuel tap is on the left side of the fuel tank.

Open or close the fuel supply to the carburetor using knurled screw **1** on the fuel tap.

Possible states

- Fuel tap is closed – Fuel cannot flow from the fuel tank to the carburetor.
- Fuel tap is open – Fuel can flow from the fuel tank to the carburetor. The fuel tank empties completely.

6.8 Choke

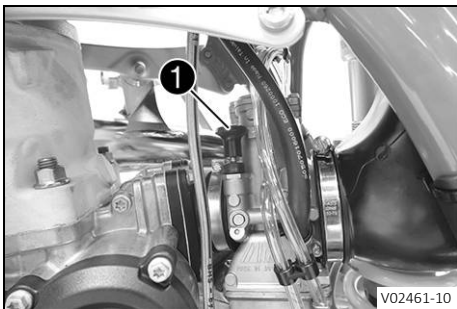

Choke **1** is fitted on the left side of the carburetor.

Activating the choke function frees a drill hole in the carburetor through which the engine can draw extra fuel. This results in a richer fuel-air mixture, which is needed for a cold start.

i Info

If the engine is warm, the choke function must be deactivated.

Possible states

- Choke function activated – The choke lever is pulled out to the stop.
- Choke function deactivated – The choke lever is pushed in to the stop.

6.9 Shift lever

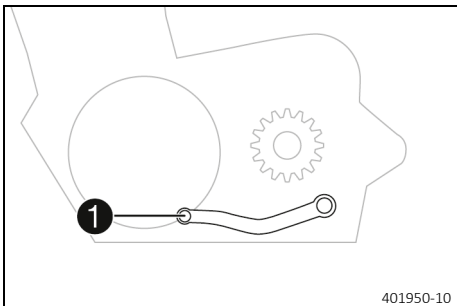

Shift lever **1** is mounted on the left of the engine.

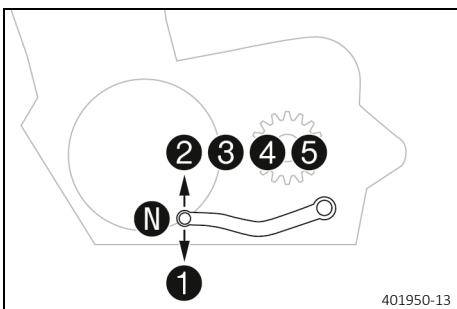

The gear positions can be seen in the photograph.

The neutral or idle position is between the first and second gears.

6.10 Kick starter lever

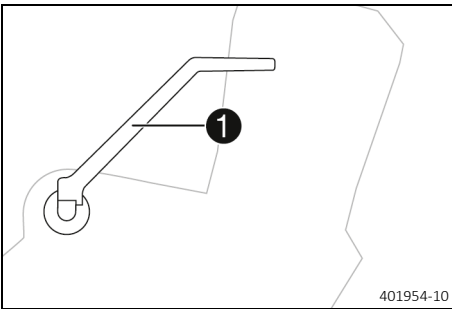

Kick starter lever **1** is fitted on the right side of the engine. The kick starter lever can be swiveled.



Info

Before riding, swing the kick starter lever inwards towards the engine.

6.11 Foot brake lever

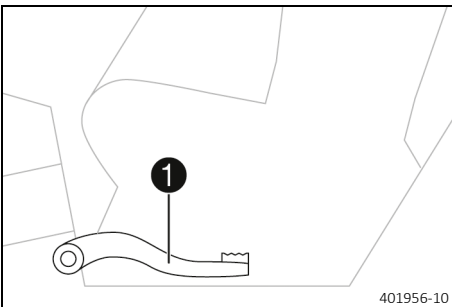

Foot brake lever **1** is located in front of the right footrest. The foot brake lever is used to activate the rear brake.

6.12 Plug-in stand

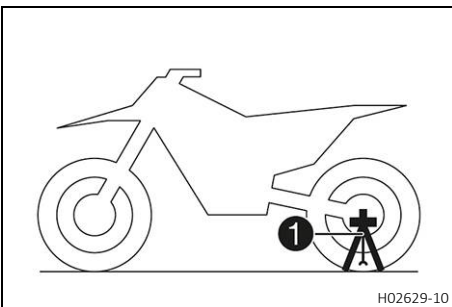

The holder for the plug-in stand **1** is the left side of the wheel spindle. The plug-in stand is used to park the motorcycle. The plug-in stand is used as a fork locker when transporting the motorcycle.



Info

Remove the plug-in stand before riding.

7.1 Advice on preparing for first use



Danger

Danger of accidents A rider who is not fit to ride poses a danger to him or herself and others.

- Do not operate the vehicle if you are not fit to ride due to alcohol, drugs or medication.
- Do not operate the vehicle if you are physically or mentally impaired.



Warning

Risk of injury Missing or poor protective clothing presents an increased safety risk.

- Wear appropriate protective clothing such as helmet, boots, gloves as well as trousers and a jacket with protectors on all rides.
- Always wear protective clothing that is in good condition and meets the legal regulations.



Warning

Danger of crashing Different tire tread patterns on the front and rear wheel impair the handling characteristic. Different tire tread patterns can make the vehicle significantly more difficult to control.

- Make sure that only tires with a similar tire tread pattern are fitted to the front and rear wheel.



Warning

Danger of accidents An unadapted riding style impairs the handling characteristic.

- Adapt your riding speed to the road conditions and your riding ability.



Warning

Danger of accidents The vehicle is not designed to carry passengers.

- Do not ride with a passenger.



Warning

Danger of accidents The brake system fails in the event of overheating.

If the foot brake lever is not released, the brake linings drag continuously.

- Take your foot off the foot brake lever if you do not want to brake.



Warning

Danger of accidents Total weight and axle loads influence the handling characteristic.

- Do not exceed the maximum permissible overall weight or the axle loads.



Warning

Risk of misappropriation People who act without authorization endanger themselves and others.

- Do not leave the vehicle unattended if the engine is running.
- Protect the vehicle against access by unauthorized persons.



Info

When using your motorcycle, remember that others may feel disturbed by excessive noise.

- Make sure that the pre-sales inspection work has been carried out by an authorized GASGAS Motorcycles workshop.
 - ✓ You will receive a delivery certificate when the vehicle is handed over.
- Before riding for the first time, read the entire Owner's Manual carefully.
- Get to know the controls.
- Adjust the basic position of the clutch lever. (📖 p. 68)
- Adjust the basic position of the hand brake lever. (📖 p. 71)
- Adjust the basic position of the foot brake lever. 🦶 (📖 p. 77)
- Adjust the basic position of the shift lever. 🦶 (📖 p. 99)

- Get used to the handling characteristics of the motorcycle on a suitable surface before undertaking more challenging trips.



Info

Your motorcycle is not approved for use on public roads. When offroad, it is recommended that you are accompanied by another person on another vehicle so that you can help each other.

- Try also to ride as slowly as possible and in a standing position to get a better feel for the motorcycle.
- Do not make any off-road trips that exceed your ability and experience.
- Hold the handlebar firmly with both hands and keep your feet on the footrests when riding.
- Do not take luggage along.
- Do not exceed the maximum permissible weight and the maximum permissible axle loads.

Guideline

Maximum permissible overall weight	335 kg (739 lb.)
Maximum permissible front axle load	145 kg (320 lb.)
Maximum permissible rear axle load	190 kg (419 lb.)

- Check the spoke tension. (📖 p. 87)



Info

The spoke tension must be checked after half an hour of operation.

- Run the engine in. (📖 p. 19)



7.2 Running in the engine

- During the running-in phase, do not exceed the specified engine performance.

Guideline

Maximum engine performance	
During the first 3 operating hours	< 70 %
During the first 5 operating hours	< 100 %



Info

The use of a service hour counter is recommended in order to be able to check the mileage at any time.

- Avoid fully opening the throttle.



7.3 Preparing the vehicle for difficult operating conditions



Info

Use of the vehicle under difficult conditions, such as on sand or on wet and muddy surfaces, can result in significantly increased wear of components, such as the drive train, brake system, or suspension components. For this reason, it may be necessary to inspect or replace parts before the next scheduled service.

- Prepare air filter box cover for securing. 🛠️ (📖 p. 57)
- Clean the air filter and air filter box. 🛠️ (📖 p. 56)



Info

Check the air filter approx. every 30 minutes.

- Check the electrical connector for humidity and corrosion and to ensure it is firmly seated.

7 PREPARING FOR USE

- » If humidity, corrosion, or damage is found:
 - Clean and dry the connector, or change it if necessary.

Difficult operating conditions are:

- Rides on dry sand. (📖 p. 20)
- Rides on wet sand. (📖 p. 21)
- Rides on wet and muddy circuits. (📖 p. 22)
- Riding at high temperatures or slow riding. (📖 p. 23)
- Riding at low temperatures and in snow. (📖 p. 24)

7.4 Preparing the vehicle for rides on dry sand



- Check the radiator cap.

Value on the radiator cap	1.8 bar (26 psi)
---------------------------	------------------

- » If the indicated value does not correspond to the setpoint value:



Warning

Danger of scalding During motorcycle operation, the coolant gets very hot and is under pressure.

- Do not open the radiator, the radiator hoses or other cooling system components if the engine or the cooling system are at operating temperature.
- Allow the cooling system and the engine to cool down before you open the radiator, the radiator hoses or other components of the cooling system.
- In the event of scalding, rinse the area affected immediately with lukewarm water.

- Change the radiator cap.



- Mount the air filter dust cover.

Air filter dust cover (79006920000)



Info

Observe the fitting instructions for **GASGAS Technical Accessories**.



- Mount the air filter sand cover.

Air filter sand cover (79006922000)



Info

Observe the fitting instructions for **GASGAS Technical Accessories**.

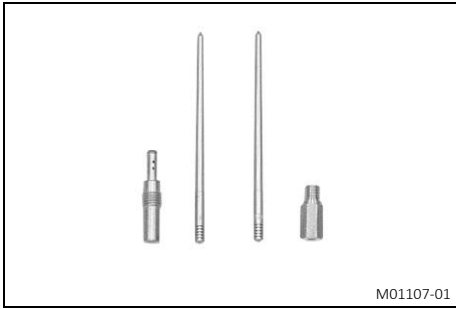

- Adjust the carburetor jetting and setting.

i Info
The recommended carburetor tuning is available from your authorized GASGAS Motorcycles workshop.



- Clean the chain.

Chain cleaner (📖 p. 122)

- Mount the steel sprocket.
- Grease the chain.

Universal oil spray (📖 p. 123)

- Clean the radiator fins.
- Straighten the bent radiator fins carefully.

Condition

Regular use in sand

- Change the piston every 10 operating hours.

7.5 Preparing the vehicle for rides on wet sand



- Check the radiator cap.

Value on the radiator cap	1.8 bar (26 psi)
---------------------------	------------------

» If the indicated value does not correspond to the setpoint value:



Warning

Danger of scalding During motorcycle operation, the coolant gets very hot and is under pressure.

- Do not open the radiator, the radiator hoses or other cooling system components if the engine or the cooling system are at operating temperature.
- Allow the cooling system and the engine to cool down before you open the radiator, the radiator hoses or other components of the cooling system.
- In the event of scalding, rinse the area affected immediately with lukewarm water.

- Change the radiator cap.

7 PREPARING FOR USE



- Mount the air filter rain cover.

Air filter rain cover (79006921000)



Info

Observe the fitting instructions for **GASGAS Technical Accessories**.

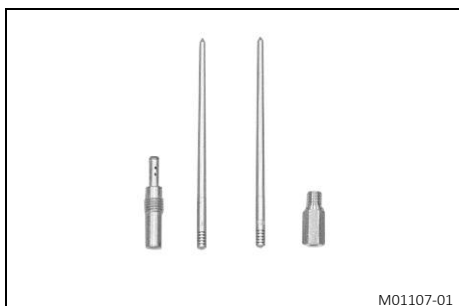

- Adjust the carburetor jetting and setting.



Info

The recommended carburetor tuning is available from your authorized GASGAS Motorcycles workshop.



- Clean the chain.

Chain cleaner (📖 p. 122)

- Mount the steel sprocket.

- Grease the chain.

Universal oil spray (📖 p. 123)

- Clean the radiator fins.

- Straighten the bent radiator fins carefully.

Condition

Regular use in sand

- Change the piston every 10 operating hours.

7.6 Preparing the vehicle for rides on wet and muddy circuits



- Mount the air filter rain cover.

Air filter rain cover (79006921000)



Info

Observe the fitting instructions for **GASGAS Technical Accessories**.

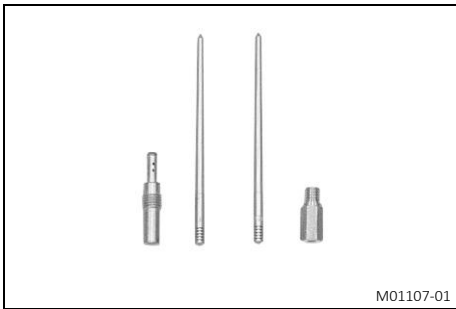

M01107-01

- Adjust the carburetor jetting and setting.

i Info
The recommended carburetor tuning is available from your authorized GASGAS Motorcycles workshop.



600868-01

- Mount the steel sprocket.
- Clean the motorcycle. (📖 p. 106)
- Straighten the bent radiator fins carefully.

7.7 Preparing vehicle for high temperatures or slow riding



M01129-01

- Check the radiator cap.

Value on the radiator cap	1.8 bar (26 psi)
---------------------------	------------------

» If the indicated value does not correspond to the setpoint value:

⚠ Warning
Danger of scalding During motorcycle operation, the coolant gets very hot and is under pressure.

- Do not open the radiator, the radiator hoses or other cooling system components if the engine or the cooling system are at operating temperature.
- Allow the cooling system and the engine to cool down before you open the radiator, the radiator hoses or other components of the cooling system.
- In the event of scalding, rinse the area affected immediately with lukewarm water.

- Change the radiator cap.

- Adjust the secondary drive to the road conditions.

i Info
The engine oil heats up quickly when the clutch is operated frequently due to an excessively high secondary ratio.



600868-01

- Clean the chain.

Chain cleaner (📖 p. 122)

- Clean the radiator fins.
- Straighten the bent radiator fins carefully.
- Check the coolant level. (📖 p. 89)

7.8 Preparing the vehicle for low temperatures or snow



- Mount the air filter rain cover.

Air filter rain cover (79006921000)



Info

Observe the fitting instructions for **GASGAS Technical Accessories**.

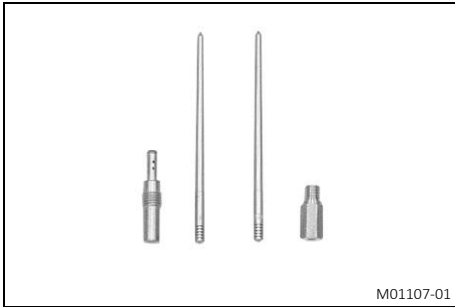

- Adjust the carburetor jetting and setting.



Info

The recommended carburetor tuning is available from your authorized GASGAS Motorcycles workshop.

8.1 Checks and maintenance measures when preparing for use

i Info

Before every trip, check the condition of the vehicle and ensure that it is safe to operate. The vehicle must be in perfect technical condition when it is being operated.

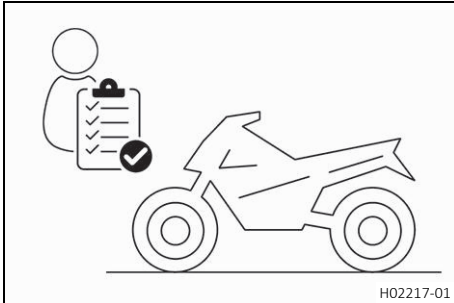

- Check the gear oil level. (📖 p. 103)
- Check the front brake fluid level. (📖 p. 72)
- Check the rear brake fluid level. (📖 p. 77)
- Check the front brake linings. (📖 p. 74)
- Check the brake linings of the rear brake. (📖 p. 79)
- Check that the brake system is functioning properly.
- Check the coolant level. (📖 p. 89)
- Check the chain for dirt. (📖 p. 61)
- Check the chain, rear sprocket, engine sprocket, and chain guide. (📖 p. 64)
- Check the chain tension. (📖 p. 62)
- Check the tire condition. (📖 p. 86)
- Check tire pressure. (📖 p. 86)
- Check the spoke tension. (📖 p. 87)

i Info

The spoke tension must be checked regularly as incorrect spoke tension will strongly impair riding safety.

- Clean the dust boots of the fork legs. (📖 p. 43)
- Bleed the fork legs. (📖 p. 42)
- Check the air filter.
- Check the settings of all controls and ensure that they can be operated smoothly.
- Check all screws, nuts, and hose clamps regularly for tightness.
- Check the fuel level.



8.2 Starting



Danger

Danger of poisoning Exhaust gases are toxic and inhaling them may result in unconsciousness and death.

- Always make sure there is sufficient ventilation when running the engine.
- Use effective exhaust extraction when starting or running the engine in an enclosed space.

Note

Engine damage High revving speed with a cold engine negatively impacts the lifespan of the engine.

- Always run the engine warm at a low speed.

i Info

If the motorcycle is unwilling to start, the cause can be old fuel in the float chamber. The flammable elements of the fuel evaporate after a long time of standing.

If the float chamber is filled with fresh fuel, the engine starts immediately.

The motorcycle has been out of use for more than 1 week

- Empty the carburetor float chamber. 🗑️ (p. 102)
- Turn the knurled screw on the fuel tap all the way counterclockwise. ✓ Fuel can flow from the fuel tank to the carburetor.
- Remove plug-in stand ①.
- Shift the transmission into neutral.

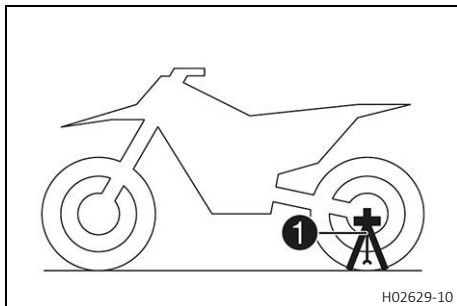

Condition

The engine is cold

- Pull the choke lever out as far as possible.
- Press the kick starter lever robustly through its full range.

i Info
Do not open the throttle.

8.3 Starting off

i Info

The plug-in stand must be removed before riding.
When you are riding, the side stand must be folded up and secured with the rubber strap.

- Pull the clutch lever, shift into first gear, release the clutch lever slowly and at the same time open the throttle carefully.

8.4 Shifting, riding



Warning

Danger of accidents If you change down at high engine speed, the rear wheel blocks and the engine races.

- Do not change into a low gear at high engine speed.

i Info

If you hear unusual noises while riding, stop immediately, switch off the engine, and contact an authorized GAS-GAS Motorcycles workshop.
First-gear is used for starting off and for steep inclines.

- Shift into a higher gear when conditions allow (incline, road situation, etc.). To do so, release the throttle while simultaneously pulling the clutch lever, shift into the next gear, release the clutch lever and open the throttle.
- If the choke function has been activated, deactivate it after the engine has warmed up.
- After reaching maximum speed by fully opening the throttle grip, turn the throttle back so it is ¾ open. This will barely reduce the speed, but fuel consumption will be considerably lower.
- Always open the throttle only as much as the engine can handle – abrupt throttle opening increases fuel consumption.
- To shift down, apply the brakes and close the throttle at the same time.
- Pull the clutch lever and shift into a lower gear, release the clutch lever slowly, and either open the throttle or shift again.
- Switch off the engine if running at idle speed or stationary for a long time.

Guideline

≥ 2 min

- Avoid frequent or lengthy slipping of the clutch. This causes the gear oil, engine and cooling system to heat up.
- Ride at a low engine speed instead of at a high engine speed with a slipping clutch.

8.5 Applying the brakes



Warning

Danger of accidents Excessively forceful application of the brakes blocks the wheels.

- Adjust application of the brakes to the respective riding situation and riding surface conditions.



Warning

Danger of accidents A spongy pressure point on the front or rear brake reduces braking efficiency.

- Check the brake system and do not continue riding until the problem is eliminated. (Your authorized GAS-GAS Motorcycles workshop will be glad to help.)



Warning

Danger of accidents Moisture and dirt impair the brake system.

- Brake carefully several times to dry out and remove dirt from the brake linings and the brake discs.

- On sandy, wet, or slippery surfaces, use the rear brake mostly if possible.
- Always finish braking before you go into a bend. Change down to a lower gear appropriate to your road speed.
- Use the braking effect of the engine on long downhill stretches. Change down one or two gears, but do not over-rev the engine. You will have to apply the brakes far less frequently as a result and the brake system will not overheat.



8.6 Stopping, parking



Warning

Risk of misappropriation People who act without authorization endanger themselves and others.

- Do not leave the vehicle unattended if the engine is running.
- Protect the vehicle against access by unauthorized persons.



Warning

Danger of burns Some vehicle components become very hot when the vehicle is operated.

- Do not touch any parts such as the exhaust system, radiator, engine, shock absorber, or brake system before the vehicle parts have cooled down.
- Let the vehicle parts cool down before you perform any work on the vehicle.

Note

Fire hazard Hot vehicle components pose a fire hazard and explosion risk.

- Do not park the vehicle near to materials which are highly flammable or explosive.
- Allow the vehicle to cool down before covering it.

Note

Material damage The vehicle may be damaged by incorrect procedure when parking.

Significant damage may be caused if the vehicle rolls away or falls over.

The components for parking the vehicle are designed only for the weight of the vehicle.

- Park the vehicle on a firm and level surface.
- Ensure that nobody sits on the vehicle when the vehicle is parked on a stand.

- Apply the brakes on the motorcycle.
- Shift the transmission to neutral position.
- Press and hold the stop button  while the engine is idling until the engine stops.
- Turn the knurled screw on the fuel tap all the way clockwise.
- Rest the vehicle on the plug-in stand.



8.7 Transporting

Note

Danger of damage The parked vehicle can roll away or fall over.

- Park the vehicle on a firm and level surface.

Note

Fire hazard Hot vehicle components pose a fire hazard and explosion risk.

- Do not park the vehicle near to materials which are highly flammable or explosive.
- Allow the vehicle to cool down before covering it.

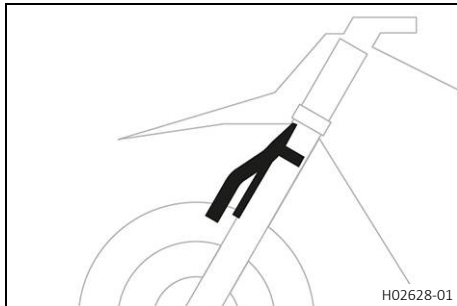

- Switch off the engine.
- Mount plug-in stand on the fork legs.

Plug-in stand (79029094000)

Info

The plug-in stand is included. Make sure the brake line runs in front of the plug-in stand and does not become wedged.

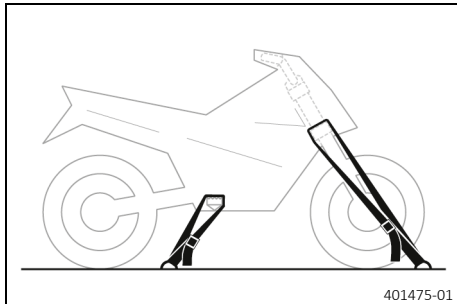

- Use tension belts or other suitable devices to secure the motorcycle against falling over or rolling away.

Info

Only tighten the tension belts to the point that the plug-in stand is firmly in contact with the fender and the tires. Pay attention to the alignment of the plug-in stand to the fender.

8.8 Refueling



Danger

Fire hazard Fuel is highly flammable.

The fuel in the fuel tank expands when warm and can escape if overfilled.

- Do not fuel the vehicle in the vicinity of open flames or lit cigarettes.
- Switch off the engine for refueling.
- Make sure that no fuel is spilled; particularly not on hot parts of the vehicle.
- If any fuel is spilled, wipe it off immediately.
- Observe the specifications for refueling.



Warning

Danger of poisoning Fuel is poisonous and a health hazard.

- Avoid skin, eye and clothing contact with fuel.
- Immediately consult a doctor if you swallow fuel.
- Do not inhale fuel vapors.
- In case of skin contact, rinse the affected area with plenty of water.
- Rinse the eyes thoroughly with water, and consult a doctor in case of fuel contact with the eyes.
- Change your clothing in case of fuel spills on them.



Note

Environmental hazard Improper handling of fuel is a danger to the environment.

- Do not allow fuel to enter the groundwater, the soil, or the sewage system.

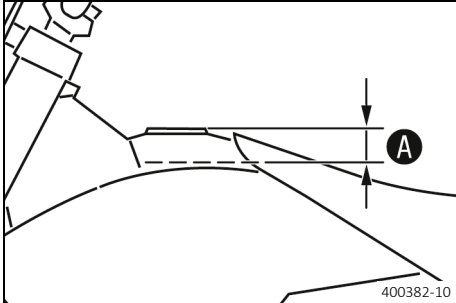

- Switch off the engine.
- Open the fuel tank filler cap. (📖 p. 15)
- Fill the fuel tank with fuel up to measurement **A**.

Guideline

Measurement of A	35 mm (1.38 in)	
Total fuel tank capacity, approx.	7.5 l (1.98 US gal)	Super unleaded (95 octane) mixed with 2-stroke engine oil (1:60) (📖 p. 121)
Engine oil, 2-stroke (📖 p. 120)		

- Close the fuel tank filler cap. (📖 p. 15)



9 SERVICE SCHEDULE

9.1 Additional information

Any further work that results from the compulsory work or from the recommended work must be ordered separately and invoiced separately.
 Different service intervals may apply in your country, depending on the local operating conditions.
 Individual service intervals and scopes may change in the course of technical developments. The most up-to-date service schedule can always be found on GASGAS Motorcycles Dealer.net. Your authorized GASGAS Motorcycles dealer will be glad to advise you.
 The use of a service hour counter is recommended in order to be able to check the mileage at any time.
 Service hour counter (A54012920000)

9.2 Required work

		after every race				
		Every 40 operating hours				
		Every 20 operating hours				
		Every 10 operating hours/after every race				
		Every 10 operating hours				
		After 5 operating hours				
		After 1 operating hour				
Change the gear oil. (📖 p. 103)	○			●	●	
Check the front brake linings. (📖 p. 74)		●	●	●	●	●
Check the brake linings of the rear brake. (📖 p. 79)		●	●	●	●	●
Check the brake discs. (📖 p. 71)		●	●	●	●	●
Check the brake lines for damage and leakage.		●	●	●	●	●
Check the rear brake fluid level. (📖 p. 77)		●	●	●	●	●
Check the free travel of the foot brake lever. (📖 p. 76)		●	●	●	●	●
Check the frame. (📖 p. 66)		●	●	●	●	●
Check the link fork. (📖 p. 66)		●	●	●	●	●
Check the fork bearing for play.				●	●	
Check the shock absorber heim joint for play.		●	●	●	●	●
Check the shock absorber linkage.		●	●	●	●	●
Check the tire condition. (📖 p. 86)	○	●	●	●	●	●
Check tire pressure. (📖 p. 86)	○	●	●	●	●	●
Check the wheel bearing for play.		●	●	●	●	●
Check the wheel hubs.		●	●	●	●	●
Check the rim run-out.	○	●	●	●	●	●
Check the spoke tension. (📖 p. 87)	○	●	●	●	●	●
Check the chain, rear sprocket, engine sprocket, and chain guide. (📖 p. 64)		●	●	●	●	●
Check the chain tension. (📖 p. 62)	○	●	●	●	●	●
Grease all moving parts (e.g., hand lever, chain, ...) and check for smooth operation.		●	●	●	●	●
Check/correct the fluid level of the hydraulic clutch. (📖 p. 68)		●	●	●	●	●
Check the front brake fluid level. (📖 p. 72)		●	●	●	●	●
Check the free travel of the hand brake lever. (📖 p. 71)		●	●	●	●	●
Check steering head bearing play. (📖 p. 48)	○	●	●	●	●	●
Change the spark plug and spark plug connector.				●	●	
Check all hoses (e.g. fuel, cooling, bleeder, drainage, etc.) and sleeves for cracking, leaks, and incorrect routing.	○	●	●	●	●	●
Check the antifreeze and coolant level. (📖 p. 88)	○	●	●	●	●	●
Check the cables for damage and for routing without kinks.		●	●	●	●	●

	after every race					
	Every 40 operating hours					
	Every 20 operating hours					
	Every 10 operating hours/after every race					
	Every 10 operating hours					
	After 5 operating hours					
	After 1 operating hour					
Check that the throttle cables are undamaged, routed without sharp bends, and set correctly.	○	●	●	●	●	●
Clean the air filter and air filter box. 🛠️ (📖 p. 56)		●	●	●	●	●
Change the glass fiber yarn filling in the main silencer. 🛠️ (📖 p. 58)				●	●	
Service the fork. 🛠️						●
Perform the shock absorber service. 🛠️						●
Check the tightness of the easily accessible, safety-relevant screws and nuts. 🛠️	○	●	●	●	●	●
Check the idle speed. 🛠️	○	●	●	●	●	●
Final check: Check the vehicle for operating safety and take for a test ride. 🛠️	○	○	●	●	●	●
Make a service entry in GASGAS Motorcycles Dealer.net . 🛠️	○	○	●	●	●	

- One-time interval
- Periodic interval

9.3 Recommended work

	every 48 months					
	every 12 months					
	Every 40 operating hours					
	After 20 operating hours / Every 20 operating hours					
	After 10 operating hours / Every 10 operating hours					
Change the front brake fluid. 🛠️					●	●
Change the rear brake fluid. 🛠️					●	●
Change the hydraulic clutch fluid. 🛠️ (📖 p. 69)					●	●
Lubricate the steering head bearing. 🛠️ (📖 p. 49)					●	●
Service the fork. 🛠️		○				
Perform the shock absorber service. 🛠️			○			
Check/adjust the carburetor components. 🛠️					●	●
Change the needle jet. 🛠️					●	●
Change the coolant. 🛠️ (📖 p. 92)						●
Perform minor engine service. (Check the reed valve housing, reed valve, and intake flange. Check the clutch. Under difficult operating conditions: Change the piston and check the cylinder and Z dimension.) 🛠️		●	●	●		
Perform the intermediate engine service. (Change the piston and check the cylinder and Z dimension. Check the exhaust control for functioning and smooth operation.) 🛠️			●	●		
Perform major engine service including removing and installing the engine. (Change the connecting rod, conrod bearing, and crank pin. Check the transmission and shift mechanism. Change all engine bearings.) 🛠️					●	

- One-time interval
- Periodic interval

10.1 Checking the basic chassis setting with the rider's weight

i Info

When adjusting the basic chassis setting, first adjust the shock absorber and then the fork.

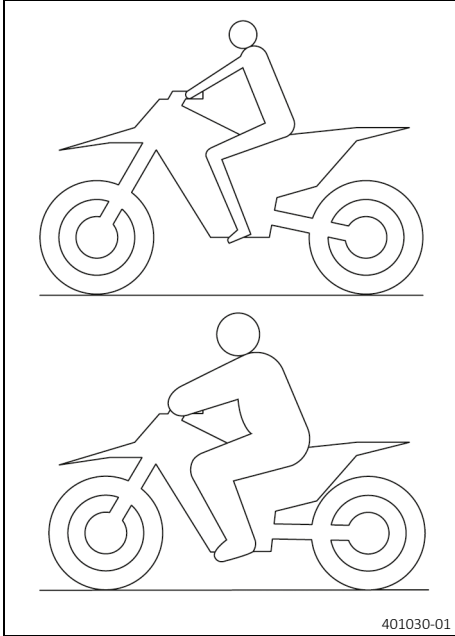

401030-01

- For optimal motorcycle riding characteristics and to avoid damage to forks, shock absorbers, link fork and frame, the basic settings of the suspension components must match the rider's weight.
- As delivered, GASGAS offroad motorcycles are adjusted for an average rider's weight (with full protective clothing).

Guideline

Standard rider weight	75 ... 85 kg (165 ... 187 lb.)
-----------------------	--------------------------------

- If the rider's weight is above or below this range, the basic setting of the suspension components must be adjusted accordingly.
- Small weight differences can be compensated by adjusting the spring preload, but in the case of large weight differences, the springs must be replaced.

10.2 Air suspension XACT 5448



M01110-01

Air suspension **WP Suspension XACT 5448** is used in the fork.

In this system, suspension is located in the left fork leg and damping in the right fork leg.

As fork springs are no longer required, a significant weight advantage is achieved when compared to conventional forks. The response on slightly uneven surfaces is significantly improved.

In normal driving mode, suspension is provided exclusively by an air cushion. A steel spring is located in the left fork leg as an end stop.

i Info

If the fork is frequently overloaded, then the air pressure in the fork must be increased to avoid damage to the fork and frame.

The air pressure in the fork can be quickly adjusted to the rider's weight, surface conditions and the rider's preference using a fork airpump. The fork does not have to be dismantled. The time consuming mounting of harder or softer fork springs is not required.

If the air chamber loses air due to a damaged seal, the fork will still not sag. In this case the air is retained in the fork. The suspension travel is maintained as far as possible. The damping becomes harder and the riding comfort reduces.

As with a conventional fork, the damping can be adjusted in rebound and compression stages.

The rebound adjuster is located at the lower end of the right fork leg. The compression adjuster is located at the upper end of the right fork leg.

10.3 Compression damping of the shock absorber

The compression damping of the shock absorber is divided into two ranges: high-speed and low-speed. High-speed and low-speed refer to the compression speed of the rear wheel suspension and not to the vehicle speed. The high-speed compression adjuster has an effect, for example, when landing after a jump: the rear wheel suspension compresses quickly. The low-speed compression adjuster has an effect, for example, when riding over long ground swells: the rear wheel suspension compresses slowly. These two ranges can be adjusted separately, although the transition between high-speed and low-speed is gradual. Thus, modifications in the high-speed range affect the compression damping in the low-speed range and vice versa.

10.4 Adjusting the low-speed compression damping of the shock absorber

Caution
Risk of injury Parts of the shock absorber will move around if the shock absorber is detached incorrectly. The shock absorber is filled with highly compressed nitrogen.
 – Please follow the description provided. (Your authorized GASGAS Motorcycles workshop will be glad to help.)

Info
 The effect of the low-speed compression adjuster can be seen in slow to normal compression of the shock absorber.

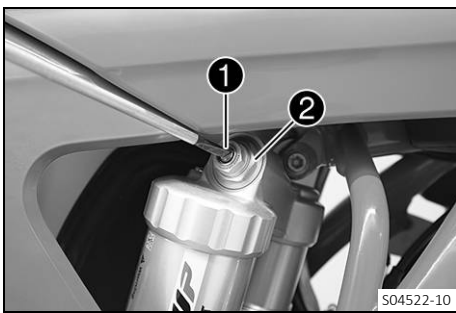

- Turn adjusting screw **1** clockwise with a screwdriver as far as the last perceptible click.

Info
 Do not loosen fitting **2**!

- Turn counterclockwise by the number of clicks corresponding to the shock absorber type.

Guideline

Lowspeed compression damping	
Comfort	17 clicks
Standard	15 clicks
Sport	13 clicks

Info
 Turn clockwise to increase damping; turn counterclockwise to reduce damping.

10.5 Adjusting the high-speed compression damping of the shock absorber

Caution
Risk of injury Parts of the shock absorber will move around if the shock absorber is detached incorrectly. The shock absorber is filled with highly compressed nitrogen.
 – Please follow the description provided. (Your authorized GASGAS Motorcycles workshop will be glad to help.)

Info
 The effect of the high speed compression adjuster can be seen in the fast compression of the shock absorber.

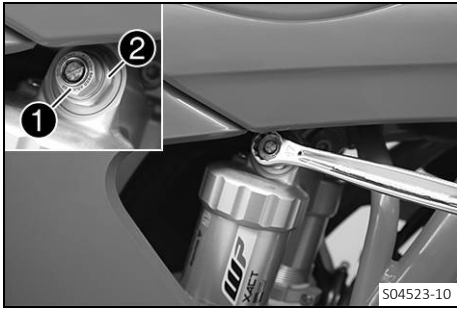

- Turn adjusting screw **1** all the way clockwise with a socket wrench.

i Info

Do not loosen fitting **2**!

- Turn counterclockwise by the number of turns corresponding to the shock absorber type.

Guideline

Highspeed compression damping	
Comfort	2.5 turns
Standard	2 turns
Sport	1.5 turns

i Info

Turn clockwise to increase damping; turn counterclockwise to reduce damping.

10.6 Adjusting the rebound damping of the shock absorber



Caution

Risk of injury Parts of the shock absorber will move around if the shock absorber is detached incorrectly. The shock absorber is filled with highly compressed nitrogen.

- Please follow the description provided. (Your authorized GASGAS Motorcycles workshop will be glad to help.)

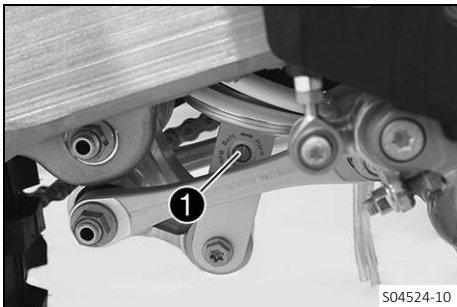

- Turn adjusting screw **1** clockwise up to the last perceptible click.
- Turn counterclockwise by the number of clicks corresponding to the shock absorber type.

Guideline

Rebound damping	
Comfort	17 clicks
Standard	15 clicks
Sport	13 clicks

i Info

Turn clockwise to increase the damping; turn counterclockwise to reduce damping when the shock absorber rebounds.

10.7 Measuring the rear wheel dimension unloaded

Preparatory work

- Raise the motorcycle with a lift stand. (📖 p. 42)

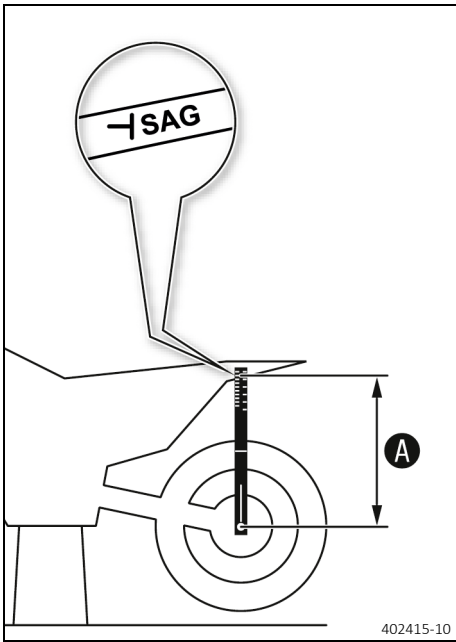

Main work

- Position the sag gage in the rear axle and measure the distance to marking **SAG** on the rear fender.

Sag gauge (00029090000)
Pin, sag scale (00029990010)

- Note down the value as dimension **A**.

Finishing work

- Remove the motorcycle from the lift stand. (📖 p. 42)

10.8 Checking the static sag of the shock absorber

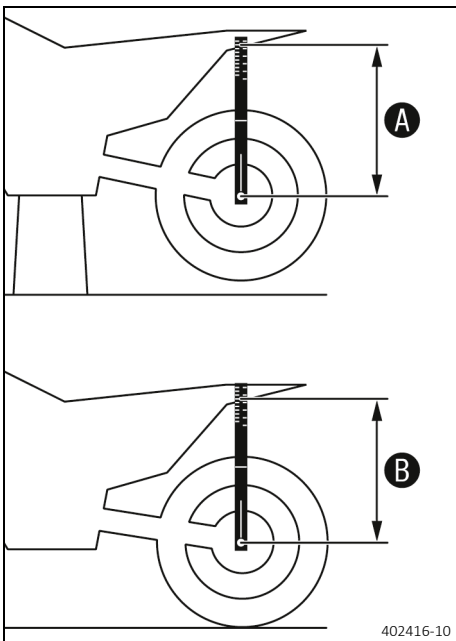

- Measure dimension **A** of rear wheel unloaded. (📖 p. 34)
- Hold the motorcycle upright with aid of an assistant.
- Measure the distance again between the rear axle and marking **SAG** on the rear fender using the sag gage.
- Note the value as dimension **B**.

i Info
The static sag is the difference between measurements **A** and **B**.

- Check the static sag.

Static sag	35 mm (1.38 in)
------------	-----------------

- » If the static sag is less or more than the specified value:
 - Adjust the spring preload of the shock absorber. (🔧 p. 36)

10.9 Checking the riding sag of the shock absorber

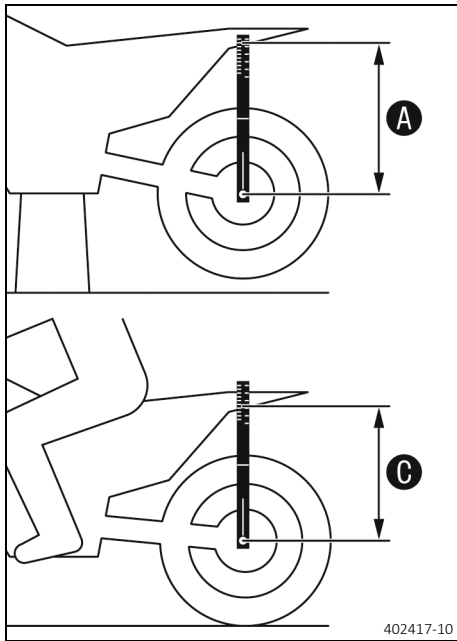

- Measure dimension **A** of rear wheel unloaded. (📖 p. 34)
- With another person holding the motorcycle, the rider, wearing full protective clothing, sits on the seat in a normal sitting position (feet on footrests) and bounces up and down a few times.
 - ✓ The rear wheel suspension levels out.
- Another person again measures the distance between the rear axle and marking **SAG** on the rear fender using the sag gage.
- Note the value as dimension **C**.



Info

The riding sag is the difference between measurements **A** and **C**.

- Check riding sag.

Guideline

Riding sag	105 mm (4.13 in)
------------	------------------

- » If the riding sag differs from the specified measurement:
 - Adjust the riding sag. 🛠️ (📖 p. 37)

10.10 Adjusting the spring preload of the shock absorber 🛠️



Caution

Risk of injury Parts of the shock absorber will move around if the shock absorber is detached incorrectly. The shock absorber is filled with highly compressed nitrogen.

- Please follow the description provided. (Your authorized GASGAS Motorcycles workshop will be glad to help.)



Info

Before changing the spring preload, make a note of the present setting, e.g., by measuring the spring length.

Preparatory work

- Raise the motorcycle with a lift stand. (📖 p. 42)
- Remove the shock absorber. 🛠️ (📖 p. 50)
- After removing the shock absorber, clean it thoroughly.

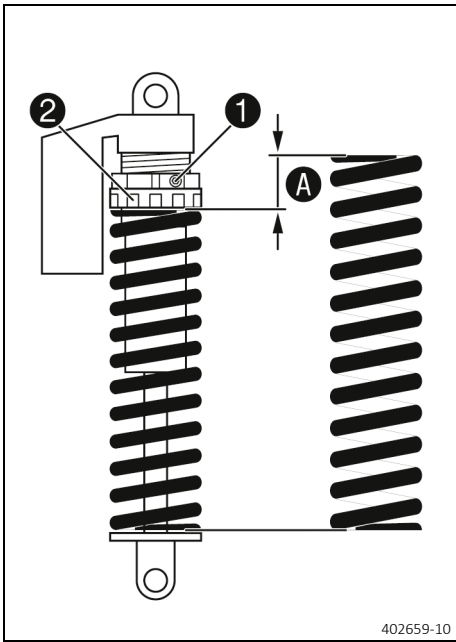

Main work

- Loosen screw ①.
- Turn adjusting ring ② until the spring is no longer under tension.

Hook wrench (90129051000)

i Info
If the spring cannot be fully released, the spring must be removed to accurately measure the spring length.

- Measure the total spring length while the spring is not under tension.
- Tension the spring by turning adjusting ring ② to specified dimension A.

Guideline

Spring preload	7 mm (0.28 in)
----------------	----------------

i Info
Depending on the static sag and/or the riding sag, it may be necessary to increase or decrease the spring preload.

- Tighten screw ①.

Guideline

Screw, shock absorber adjusting ring	M5	5 Nm (3.7 lbf ft)
--------------------------------------	----	-------------------

Finishing work

- Install the shock absorber. (🔧 p. 52)
- Remove the motorcycle from the lift stand. (📖 p. 42)

10.11 Adjusting the riding sag

Preparatory work

- Raise the motorcycle with a lift stand. (📖 p. 42)
- Remove the shock absorber. (🔧 p. 50)
- After removing the shock absorber, clean it thoroughly.

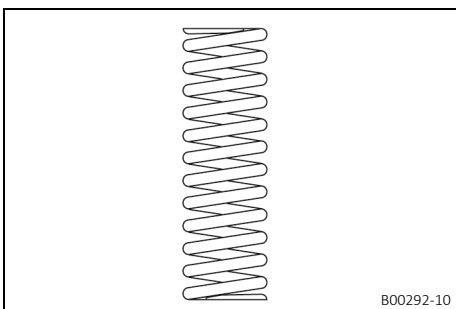

Main work

- Choose and mount a suitable spring.

Guideline

Spring rate	
Weight of rider: 65 ... 75 kg (143 ... 165 lb.)	39 N/mm (223 lb/in)
Weight of rider: 75 ... 85 kg (165 ... 187 lb.)	42 N/mm (240 lb/in)
Weight of rider: 85 ... 95 kg (187 ... 209 lb.)	45 N/mm (257 lb/in)

i Info
The spring rate is shown on the outside of the spring.

Finishing work

- Install the shock absorber. (🔧 p. 52)
- Remove the motorcycle from the lift stand. (📖 p. 42)

- Check the static sag of the shock absorber. (📖 p. 35)
- Check the riding sag of the shock absorber. (📖 p. 36)
- Adjust the rebound damping of the shock absorber. (📖 p. 34)

10.12 Checking the basic setting of the fork

i Info

For various reasons, no exact riding sag can be determined for the fork.

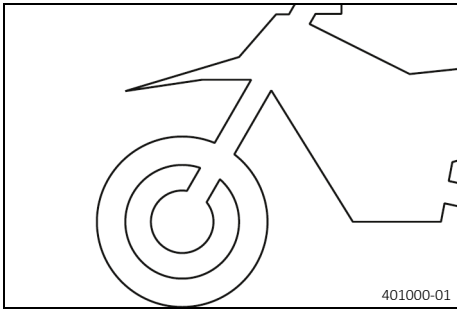

- Smaller differences in the rider's weight can be compensated for by the fork air pressure.
- However, if the fork frequently bottoms out (hard end stop on compression), the fork air pressure must be increased, within the specified values, to avoid damage to the fork and frame.
- If the fork feels unusually hard after extended periods of operation, the fork legs need to be bled.

10.13 Adjusting the fork air pressure



Warning

Danger of accident Modifications to the suspension setting may seriously alter the handling characteristic.

Extreme modifications to the suspension setting may cause a serious deterioration in the handling characteristic and overload components.

- Only make adjustments within the recommended range.
- Ride slowly to start with after making adjustments to get the feel of the new handling characteristic.

i Info

Check or adjust the air pressure under the same conditions at the earliest 5 minutes after switching off the engine. The air suspension is located in the left fork leg. The pressure and rebound damping is located in the right fork leg.

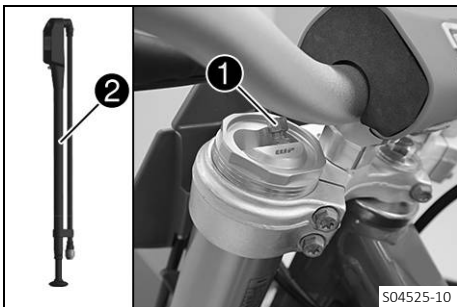

Preparatory work

- Raise the motorcycle with a lift stand. (📖 p. 42)

Main work

- Remove protection cap **1**.
- Push together fork airpump **2** fully.

Fork airpump (79412966100)

i Info

The fork airpump is included as part of the motorcycle's accessory pack.

- Connect the fork airpump to the left fork leg.
 - ✓ The fork airpump indicator switches on automatically.
 - ✓ A little air escapes from the fork leg when connecting.

i Info
 This is due to the volume of the hose and not due to a defect in the fork airpump or the fork.
 Read the accompanying **GASGAS Technical Accessories** instructions.

- Adjust the air pressure as specified.

Guideline

Air pressure	10.4 bar (151 psi)
Gradual changing of the air pressure in steps of	0.2 bar (3 psi)
Minimum air pressure	7 bar (102 psi)
Maximum air pressure	12 bar (174 psi)

i Info
 Never adjust the air pressure to a value outside the stated range.

- Disconnect the fork airpump from the left fork leg.
 - ✓ When disconnecting, excess pressure will escape from the hose – the fork leg itself does not lose any air.
 - ✓ The fork airpump indicator switches off automatically after 80 seconds.
- Mount the protection cap.

i Info
 Only mount the protection cap by hand.

Finishing work

- Remove the motorcycle from the lift stand. (📖 p. 42)



10.14 Adjusting the compression damping of the fork

i Info
 The hydraulic compression damping determines the fork suspension behavior.

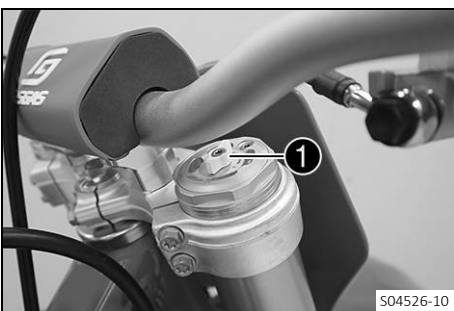

S04526-10

- Turn adjuster **1** clockwise all the way to the stop.

i Info
 Adjuster **1** is located at the upper end of the right fork leg.

- Turn counterclockwise by the number of clicks corresponding to the fork type.

Guideline

Compression damping	
Comfort	17 clicks
Standard	12 clicks
Sport	7 clicks



Info

Turn clockwise to increase damping; turn counterclockwise to reduce damping during compression.

10.15 Adjusting the rebound damping of the fork



Info

The hydraulic rebound damping determines the fork suspension behavior.

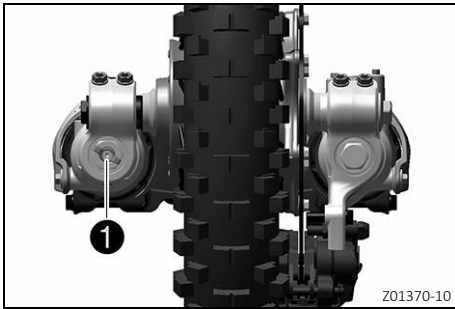

- Turn adjuster ① clockwise all the way to the stop.



Info

Adjuster ① is located at the lower end of the right fork leg.

- Turn counterclockwise by the number of clicks corresponding to the fork type.

Guideline

Rebound damping	
Comfort	23 clicks
Standard	18 clicks
Sport	13 clicks



Info

Turn clockwise to increase the damping; turn counterclockwise to reduce damping when the shock absorber rebounds.

10.16 Handlebar position

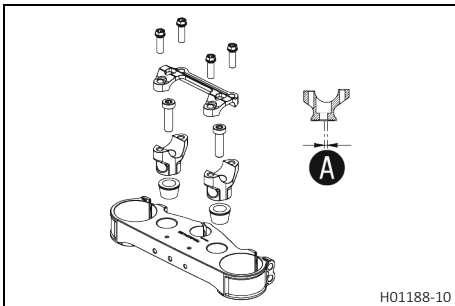

The holes on the handlebar supports are placed at a distance of A from the center.

Hole distance A	3.5 mm (0.138 in)
-----------------	-------------------

The handlebar can be mounted in 2 different positions. In this way, the handlebar can be mounted in the most comfortable position for the rider.

10.17 Adjusting the handlebar position



Warning

Danger of accidents A repaired handlebar poses a safety risk.

If the handlebar is bent or straightened, the material becomes fatigued. The handlebar may break as a result.

- Change the handlebar if the handlebar is damaged or bent.

Preparatory work

- Remove the handlebar cushion.

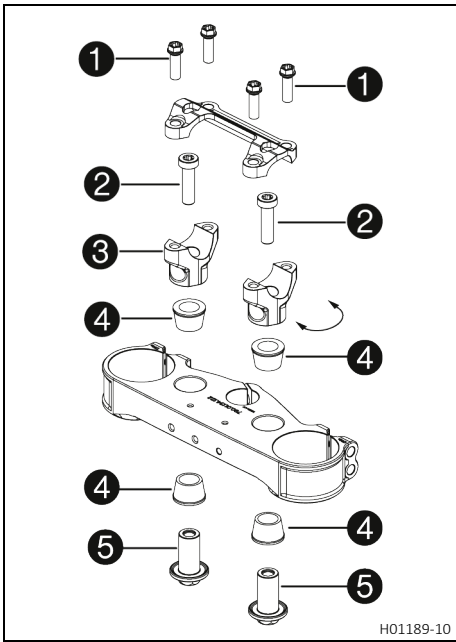

Main work

- Remove screws **1**. Remove the handlebar clamp. Remove the handlebar and lay it to one side.

i Info
Cover the components to protect them against damage. Do not kink the cables and lines.

- Remove screws **2**. Take off handlebar supports **3**.
- Position rubber bushings **4** and push through nuts **5** from below.
- Place the handlebar supports in the required position.

i Info
The handlebar supports are longer and higher on one side. Position the left and right handlebar supports evenly.

- Mount and tighten screws **2**.

Guideline

Screw, handlebar support	M10	40 Nm (29.5 lbf ft) Loctite®243™
--------------------------	-----	--

- Position the handlebar.

i Info
Make sure the cables and wiring are positioned correctly.

- Position the handlebar clamp.
- Mount screws **1** but do not tighten yet.
- First bolt the handlebar clamp with screws **1** onto the longer, higher side of the handlebar supports so that both parts touch.

Guideline

Screw, handlebar clamp	M8	20 Nm (14.8 lbf ft)
------------------------	----	---------------------

- Tighten screws **1** evenly.

Guideline

Screw, handlebar clamp	M8	20 Nm (14.8 lbf ft)
------------------------	----	---------------------

Finishing work

- Mount the handlebar cushion.



11.1 Raising the motorcycle with a lift stand

Note

Material damage The vehicle may be damaged by incorrect procedure when parking. Significant damage may be caused if the vehicle rolls away or falls over. The components for parking the vehicle are designed only for the weight of the vehicle.

- Park the vehicle on a firm and level surface.
- Ensure that nobody sits on the vehicle when the vehicle is parked on a stand.

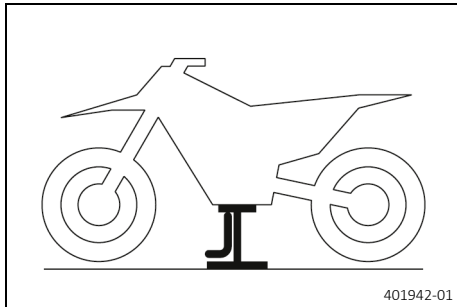

- Raise the motorcycle at the frame underneath the engine.

Lift stand (A54029955100)

- ✓ Neither wheel is in contact with the ground.
- Secure the motorcycle against falling over.

11.2 Removing the motorcycle from the lift stand

Note

Material damage The vehicle may be damaged by incorrect procedure when parking. Significant damage may be caused if the vehicle rolls away or falls over. The components for parking the vehicle are designed only for the weight of the vehicle.

- Park the vehicle on a firm and level surface.
- Ensure that nobody sits on the vehicle when the vehicle is parked on a stand.

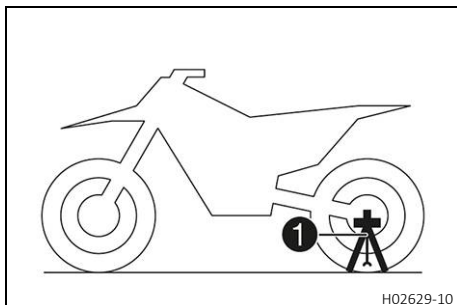

- Remove the motorcycle from the lift stand.
- Remove the lift stand.
- To park the motorcycle, insert plug-in stand ① into the left side of the wheel spindle.

Info

Remove the plug-in stand before riding.

11.3 Bleeding the fork legs

Preparatory work

- Raise the motorcycle with a lift stand. (📖 p. 42)

Main work

- Release bleeder screws ①.
 - ✓ Any excess pressure escapes from the interior of the fork.
- Tighten the bleeder screws.

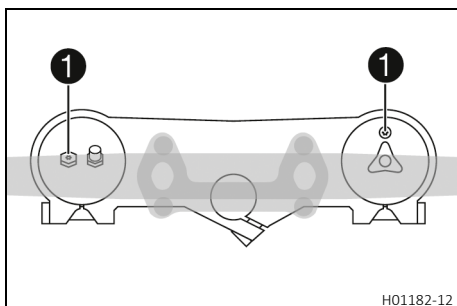

Finishing work

- Remove the motorcycle from the lift stand. (📖 p. 42)



11.4 Cleaning the dust boots of the fork legs

Preparatory work

- Raise the motorcycle with a lift stand. (📖 p. 42)
- Remove the fork protector. (📖 p. 45)

Main work

- Push dust boots ❶ of both fork legs downward.



Info

The dust boots remove dust and coarse dirt particles from the inside fork tubes. Over time, dirt can accumulate behind the dust boots. If this dirt is not removed, the oil seals behind can start to leak.



Warning

Danger of accidents Oil or grease on the brake discs reduces the braking effect.

- Always keep the brake discs free of oil and grease.
- Clean the brake discs with brake cleaner when necessary.

- Clean and oil the dust boots and inner fork tubes of both fork legs.

Universal oil spray (📖 p. 123)

- Press the dust boots back into their normal position.
- Remove excess oil.

Finishing work

- Install the fork protector. (📖 p. 45)
- Remove the motorcycle from the lift stand. (📖 p. 42)



11.5 Removing the fork legs

Preparatory work

- Raise the motorcycle with a lift stand. (📖 p. 42)
- Remove the front wheel. 🛠️ (📖 p. 82)

Main work

- Remove screws ❶ and take off the clamp.
- Remove screws ❷ and take off the brake caliper.
- Allow the brake caliper and brake line to hang loosely to the side.

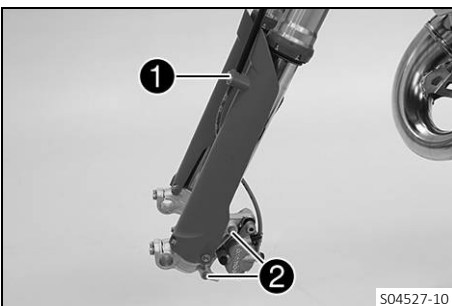

Info

Do not actuate the hand brake lever when the front wheel is removed.

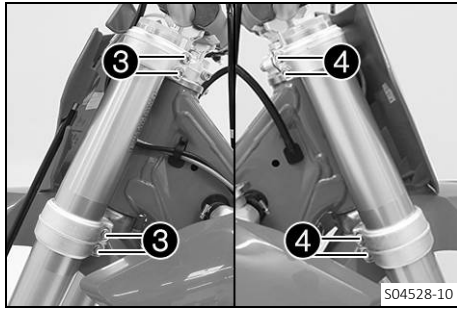

- Loosen screws **3**. Remove the left fork leg.
- Loosen screws **4**. Remove the right fork leg.

11.6 Installing the fork legs

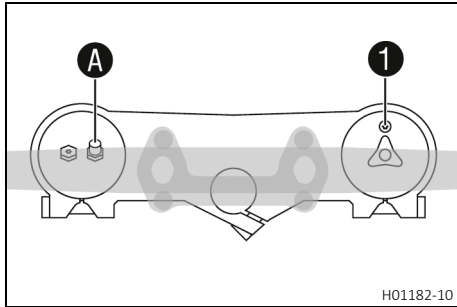

Main work

- Position the fork legs.
 - ✓ Air bleeder screw **1** of the right fork leg is positioned to the front.
 - ✓ Valve **A** of the left fork leg faces the front.



Info

Grooves are milled into the side of the upper end of the fork legs. The second milled groove (from the top) must be flush with the upper edge of the upper triple clamp. The air suspension is located in the left fork leg. The pressure and rebound damping is located in the right fork leg.

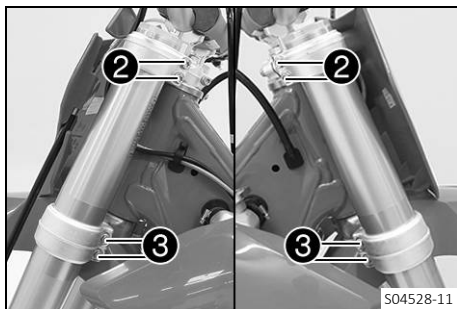

- Tighten screws **2**.

Guideline

Screw, top triple clamp	M8	20 Nm (14.8 lbf ft)
-------------------------	----	---------------------

- Tighten screws **3**.

Guideline

Screw, bottom triple clamp	M8	15 Nm (11.1 lbf ft)
----------------------------	----	---------------------

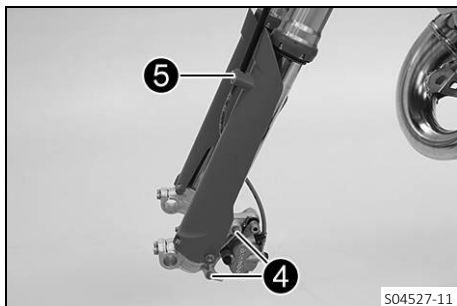

- Position the brake caliper. Mount and tighten screws **4**.

Guideline

Screw, front brake caliper	M8	25 Nm (18.4 lbf ft) Loctite®243™
----------------------------	----	--

- Position the brake line and the clamp. Mount and tighten screws **5**.

Finishing work

- Install the front wheel. p. 83

11.7 Removing the fork protector

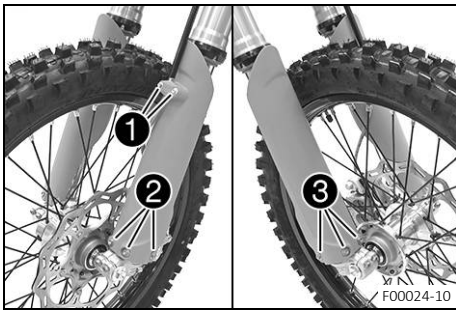

- Remove screws **1**. Remove the clamp.
- Remove screws **2**. Take off the left fork protector.
- Remove screws **3**. Take off the right fork protector.

11.8 Installing the fork protector

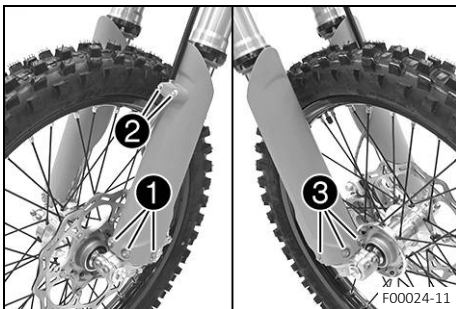

- Position the fork protection on the left fork leg. Mount and tighten screws **1**.

Guideline

Remaining screws, chassis	M6	10 Nm (7.4 lbf ft)
---------------------------	----	--------------------

- Position the brake line and clamp. Mount and tighten screws **2**.
- Position the fork protector on the right fork leg. Mount and tighten screws **3**.

Guideline

Remaining screws, chassis	M6	10 Nm (7.4 lbf ft)
---------------------------	----	--------------------

11.9 Removing the lower triple clamp

Preparatory work

- Raise the motorcycle with a lift stand. (📖 p. 42)
- Remove the front wheel. 🛠️ (📖 p. 82)
- Remove the fork legs. 🛠️ (📖 p. 43)
- Remove the start number plate. (📖 p. 49)
- Remove front fender. (📖 p. 50)
- Remove the handlebar cushion.

Main work

- Remove screw **1**.
- Remove screw **2**.
- Take off the upper triple clamp with the handlebar and hang them to the side.

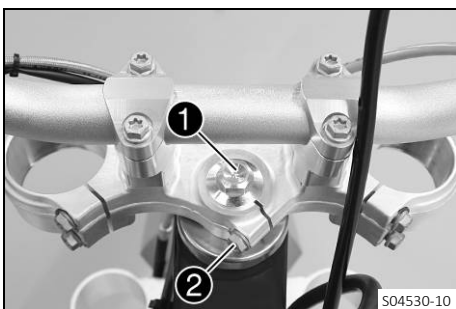

Info

Cover the components to protect them against damage. Do not kink the cables and lines.

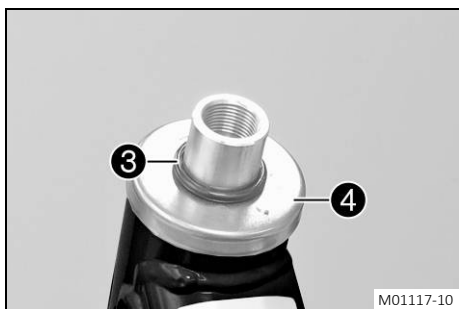

- Remove O-ring ③. Remove protective ring ④.
- Take off the lower triple clamp with the steering stem.
- Remove the upper steering head bearing.

11.10 Installing the lower triple clamp

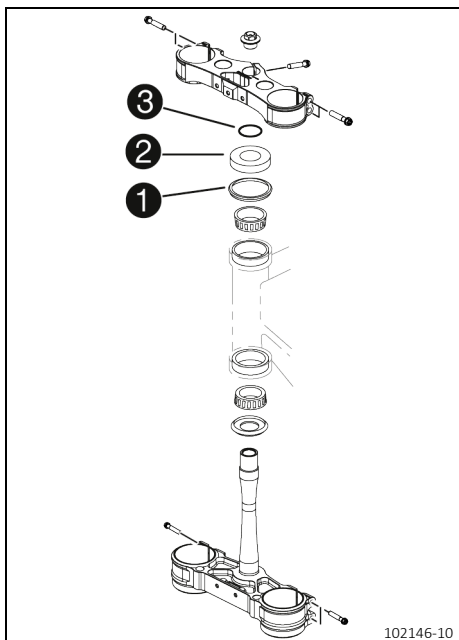

Main work

- Clean the bearing and sealing elements, check for damage, and grease.
- High viscosity grease (📖 p. 122)
- Insert the lower triple clamp with the steering stem. Mount upper steering head bearing.
 - Check whether upper steering head seal ① is correctly positioned.
 - Slide on protective ring ② and O-ring ③.

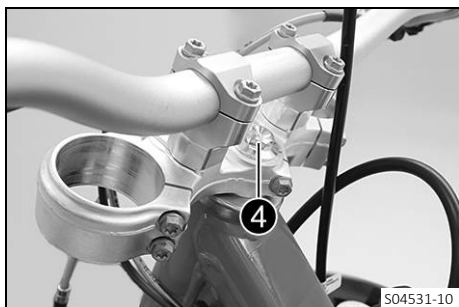

- Position the upper triple clamp with the handlebar.
- Mount screw ④, but do not tighten yet.

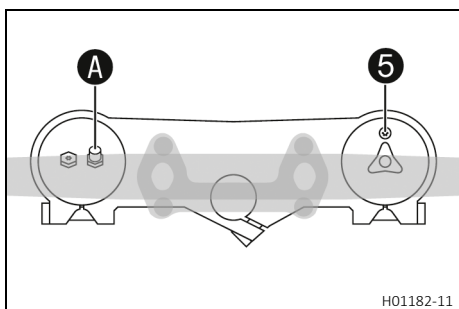

- Position the fork legs.
- ✓ Air bleeder screw ⑤ of the right fork leg is positioned to the front.
- ✓ Valve A of the left fork leg faces the front.

Info

The air suspension **AER** valve is located in the left fork leg. Grooves are milled into the side of the upper end of the fork legs. The second milled groove (from the top) must be flush with the upper edge of the upper triple clamp.

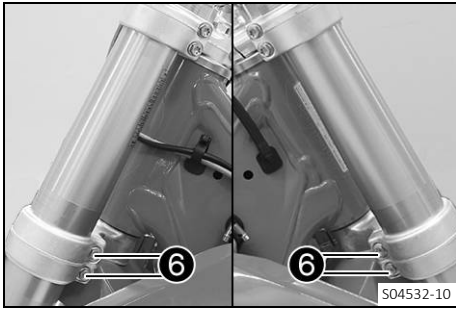

- Tighten screws **6**.

Guideline

Screw, bottom triple clamp	M8	15 Nm (11.1 lbf ft)
----------------------------	----	---------------------

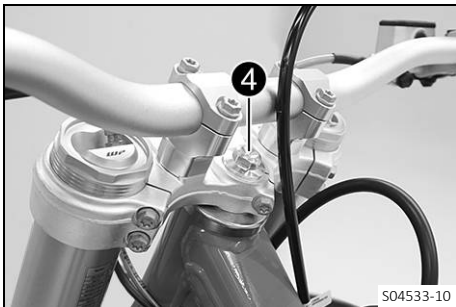

- Tighten screw **4**.

Guideline

Screw, top steering head	M20x1.5	12 Nm (8.9 lbf ft)
--------------------------	---------	--------------------

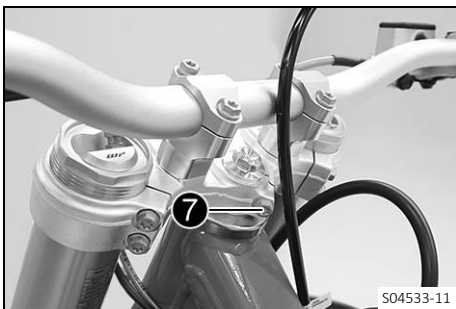

- Mount and tighten screw **7**.

Guideline

Screw, top steering stem	M8	20 Nm (14.8 lbf ft) Loctite®243™
--------------------------	----	--

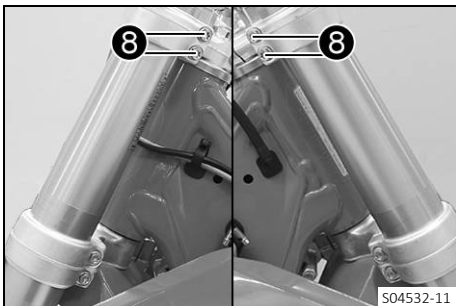

- Tighten screws **8**.

Guideline

Screw, top triple clamp	M8	20 Nm (14.8 lbf ft)
-------------------------	----	---------------------

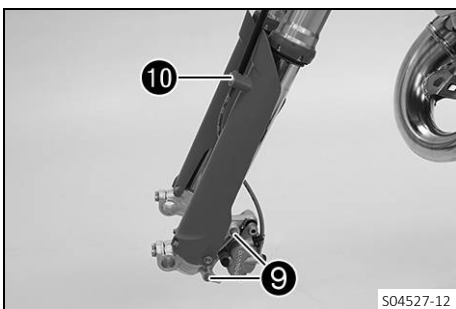

- Position the brake caliper. Mount and tighten screws **9**.

Guideline

Screw, front brake caliper	M8	25 Nm (18.4 lbf ft) Loctite®243™
----------------------------	----	--

- Position the brake line and the clamp. Mount and tighten screws **10**.

Finishing work

- Check that the wiring harness, throttle cables, and brake and clutch lines can move freely and are routed correctly.
- Install front fender. (📖 p. 50)
- Install the front wheel. 🛠️ (📖 p. 83)

- Check steering head bearing play. (📖 p. 48)
- Remove the motorcycle from the lift stand. (📖 p. 42)
- Install the start number plate. (📖 p. 49)
- Mount the handlebar cushion.

11.11 Checking steering head bearing play



Warning

Danger of accidents Incorrect steering head bearing play impairs the handling characteristic and damages components.

- Correct incorrect steering head bearing play immediately. (Your authorized GASGAS Motorcycles workshop will be glad to help.)



Info

If the vehicle is operated for a lengthy period with play in the steering head bearing, the bearings and the bearing seats in the frame can become damaged over time.

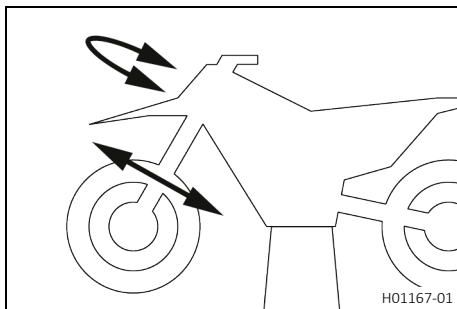

Preparatory work

- Raise the motorcycle with a lift stand. (📖 p. 42)

Main work

- Move the handlebar to the straight-ahead position. Move the fork legs to and fro in the direction of travel.

Play should not be detectable on the steering head bearing.

- » If there is detectable play:
 - Adjust steering head bearing play. (🔧📖 p. 48)

- Move the handlebar to and fro over the entire steering range.

It must be possible to move the handlebar easily over the entire steering range. There should be no detectable detent positions.

- » If detent positions are detected:
 - Adjust steering head bearing play. (🔧📖 p. 48)
 - Check the steering head bearing and change if necessary.

Finishing work

- Remove the motorcycle from the lift stand. (📖 p. 42)

11.12 Adjusting steering head bearing play 🔧

Preparatory work

- Raise the motorcycle with a lift stand. (📖 p. 42)
- Remove the handlebar cushion.

Main work

- Loosen screws ①.
- Remove screw ②.
- Loosen and retighten screw ③.

Guideline

Screw, top steering head	M20x1.5	12 Nm (8.9 lbf ft)
--------------------------	---------	--------------------

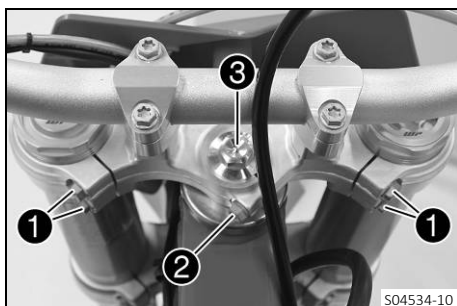

- Using a plastic hammer, tap lightly on the upper triple clamp to avoid stresses.
- Tighten screws ❶.

Guideline

Screw, top triple clamp	M8	20 Nm (14.8 lbf ft)
-------------------------	----	---------------------

- Mount and tighten screw ❷.

Guideline

Screw, top steering stem	M8	20 Nm (14.8 lbf ft) Loctite®243™
--------------------------	----	--

Finishing work

- Check steering head bearing play. (📖 p. 48)
- Remove the motorcycle from the lift stand. (📖 p. 42)
- Mount the handlebar cushion.



11.13 Lubricating the steering head bearing 🛠️

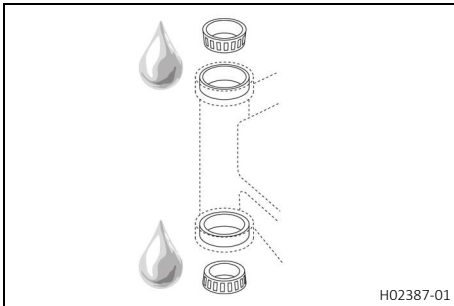

- Remove the lower triple clamp. 🛠️ (📖 p. 45)
- Install the lower triple clamp. 🛠️ (📖 p. 46)



Info

The steering head bearing is cleaned and lubricated in the course of removal and installation.



11.14 Removing the start number plate

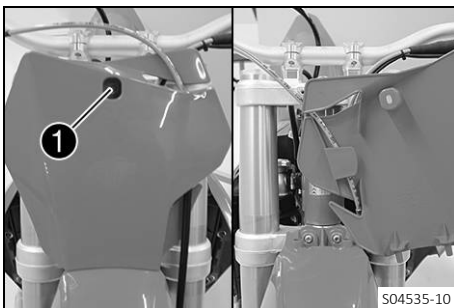

- Remove screw ❶.
- Disconnect the brake line at the start number plate. Take off the start number plate.



11.15 Installing the start number plate

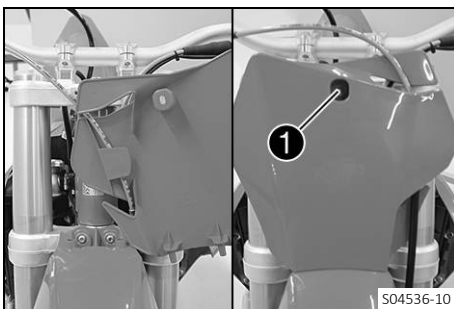

- Connect the brake line at the start number plate.
- Position the start number plate.
 - ✓ The holding lugs engage in the fender.
- Mount and tighten screw ❶.



11.16 Removing front fender

Preparatory work

- Remove the start number plate. (📖 p. 49)

Main work

- Remove screws **1** and **2**. Remove front fender.

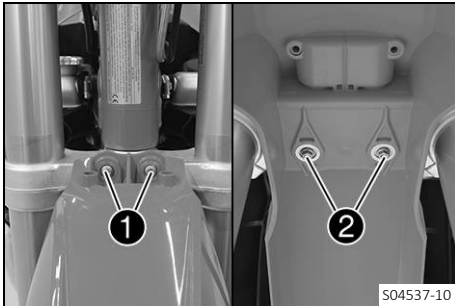

11.17 Installing front fender

Main work

- Position front fender. Mount and tighten screws **1** and **2**.

Guideline

Remaining screws, chassis	M6	10 Nm (7.4 lbf ft)
---------------------------	----	--------------------

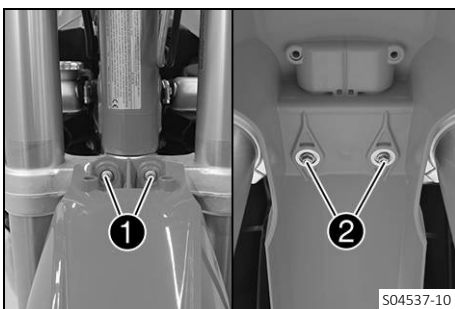

Finishing work

- Install the start number plate. (📖 p. 49)

11.18 Removing the shock absorber

Preparatory work

- Raise the motorcycle with a lift stand. (📖 p. 42)

Main work

- Remove the cable ties.
- Remove screws **1** along with the washers.
- Take off the left frame protector.
- Push the right frame protector to the front and take off at the bottom.

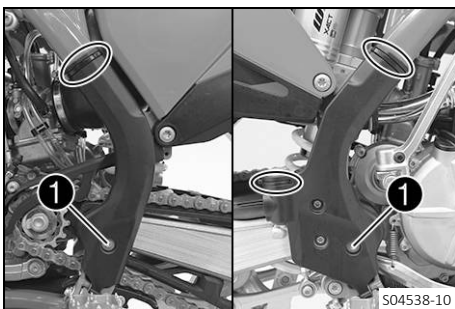

- Remove screw **2**.
- Remove fitting **3**.



Info

Raise the wheel slightly to be able to remove the screws more easily.

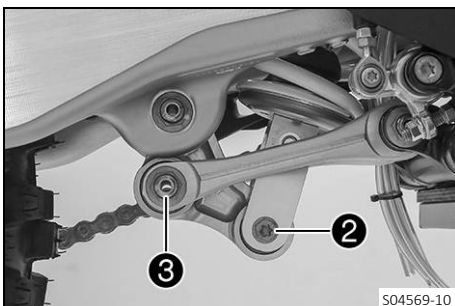

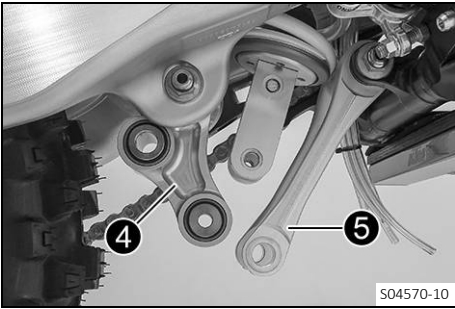

- Press angle lever **4** toward the rear.
- Press linkage lever **5** downward.

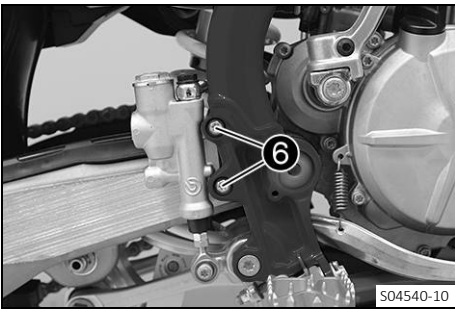

- Remove screws **6** and pull foot brake cylinder off the push rod.

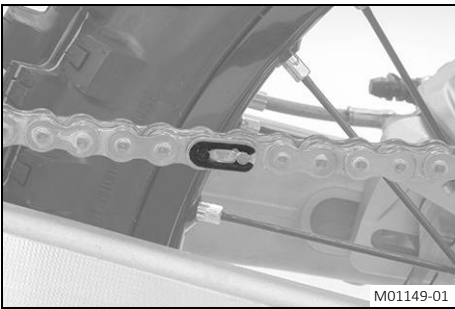

- Remove the connecting link of the chain.
- Take off the chain.

i Info
Cover the components to protect them against damage.



- Remove nut **7** and pull out the swingarm pivot.
- Push the link fork back and secure it against falling over.



- Hold the shock absorber and remove screw **8**.



- Remove the shock absorber carefully at the bottom.

11.19 Installing the shock absorber



Main work

- Carefully position the shock absorber into the vehicle from the bottom.



- Mount and tighten screw ①.

Guideline

Screw, top shock absorber	M10	60 Nm (44.3 lbf ft) Loctite®2701™
---------------------------	-----	---

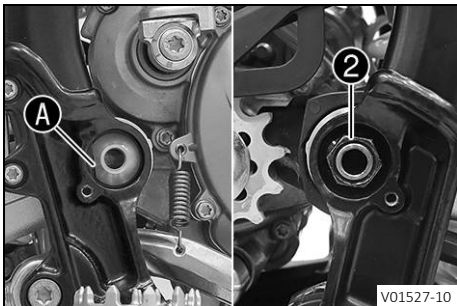

- Position the link fork and mount the swingarm pivot.



Info

Pay attention to flat area A.

- Mount and tighten nut ②.

Guideline

Nut, fork pivot	M16x1.5	100 Nm (73.8 lbf ft)
-----------------	---------	----------------------

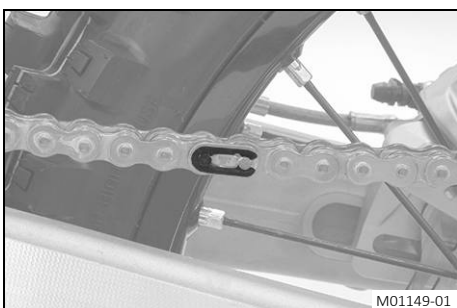

- Mount the chain.
- Connect the chain with the connecting link.

Guideline

The closed side of the chain joint lock must face in the direction of travel.

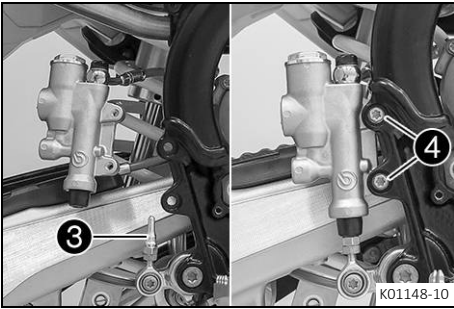

- Position the foot brake cylinder.
- ✓ Push rod **3** engages in the foot brake cylinder.
- ✓ The dust boot is correctly positioned.
- Mount and tighten screws **4**.

Guideline

Remaining screws, chassis	M6	10 Nm (7.4 lbf ft)
---------------------------	----	--------------------

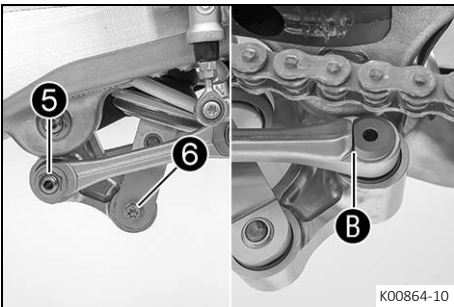

- Position the angle lever and linkage lever.
- Mount and tighten fitting **5**.

Guideline

Nut, linkage lever on angle lever	M14x1.5	60 Nm (44.3 lbf ft)
-----------------------------------	---------	---------------------

i **Info**
Pay attention to flat area **B**.

- Mount and tighten screw **6**.

Guideline

Screw, bottom shock absorber	M10	60 Nm (44.3 lbf ft) Loctite®2701™
------------------------------	-----	---

i **Info**
Raise the wheel slightly to be able to mount the screw more easily.

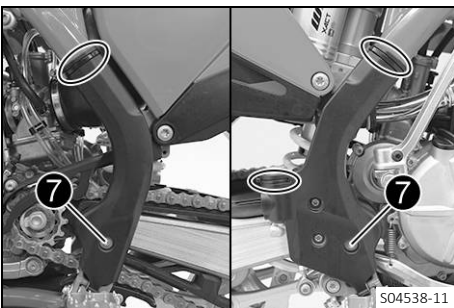

- Position the left frame protector.
- Insert the right frame protector from below and push it to the rear.
- Mount and tighten screws **7** with the washers.

Guideline

Screw, frame protector	M5	3 Nm (2.2 lbf ft)
------------------------	----	-------------------

- Mount the new cable ties.

Finishing work

- Remove the motorcycle from the lift stand. (📖 p. 42)

11.20 Removing the seat

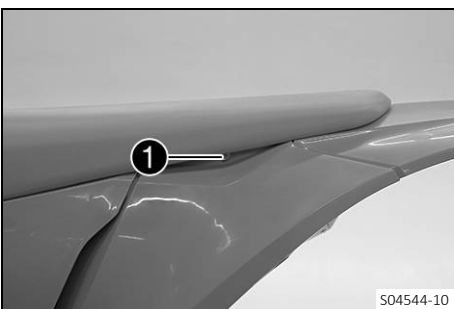

- Remove screw **1**.

11 SERVICE WORK ON THE CHASSIS

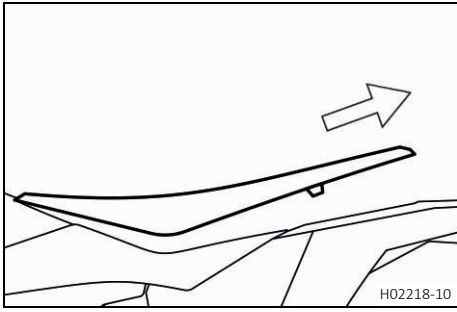

- Raise the rear of the seat, pull the seat back, and lift it off.

11.21 Mounting the seat

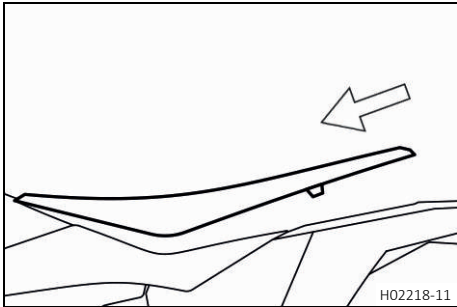

- Mount the front of the seat on the collar bushing of the fuel tank, lower the seat at the rear, and push the seat forward.
- Make sure that the seat is locked in correctly.

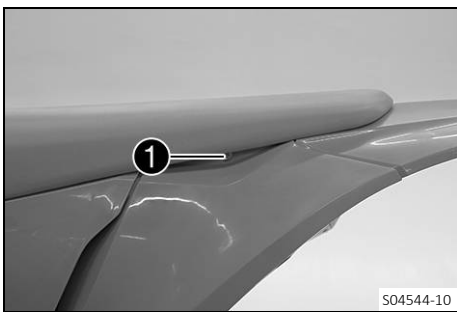

- Mount and tighten screw 1.

Guideline

Remaining screws, chassis	M6	10 Nm (7.4 lbf ft)
---------------------------	----	--------------------

11.22 Removing the air filter box cover

Condition

The air filter box cover is secured.

- Remove the seat. (📖 p. 53)
- Remove screw 1.

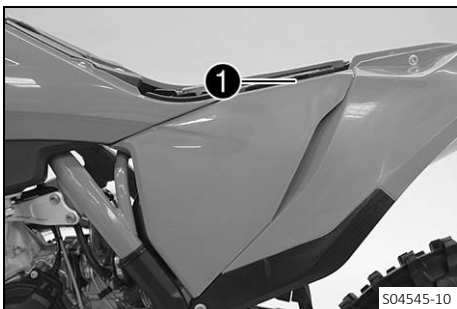

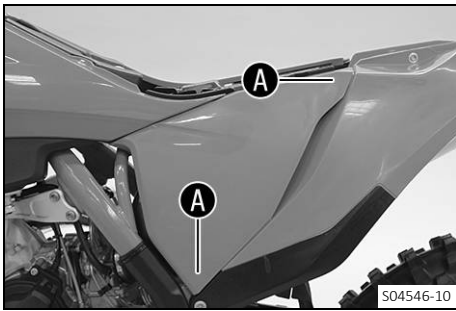

- Pull off the air filter box cover in area **A** sideways and take off toward the front.

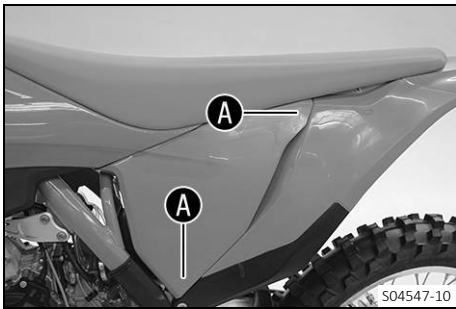

Condition

The air filter box cover is not secured.

- Pull off the air filter box cover in area **A** sideways and take off toward the front.

11.23 Installing the air filter box cover

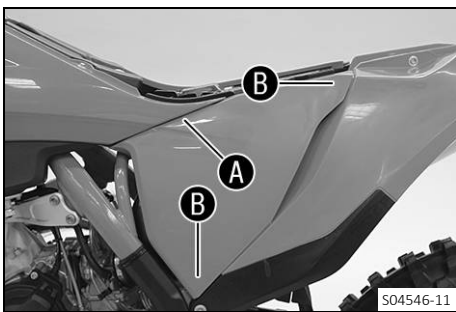

Condition

The air filter box cover is secured.

- Insert the air filter box cover in area **A** and clip it into area **B**.

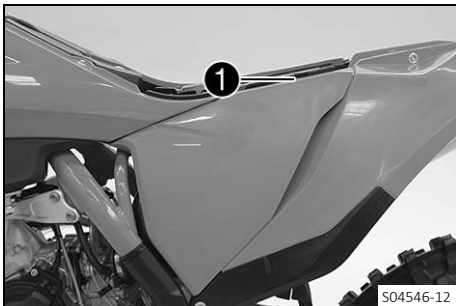

- Mount and tighten screw **1**.

Guideline

Screw, air filter box cover	EJOT PT® K60x20-Z	3 Nm (2.2 lbf ft)
-----------------------------	-----------------------------	-------------------

- Mount the seat. (📖 p. 54)

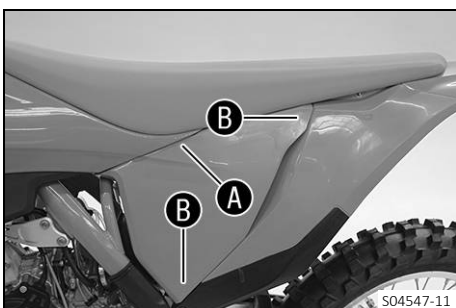

Condition

The air filter box cover is not secured.

- Insert the air filter box cover in area **A** and clip it into area **B**.

11.24 Removing the air filter 🛠️

Note

Engine damage Unfiltered intake air has a negative effect on the service life of the engine. Dust and dirt will enter the engine without an air filter.

- Only operate the vehicle if it is equipped with an air filter.



Note

Environmental hazard Hazardous substances cause environmental damage.

- Dispose of oils, grease, filters, fuel, cleaning agents, brake fluid, etc., correctly and in compliance with the applicable regulations.

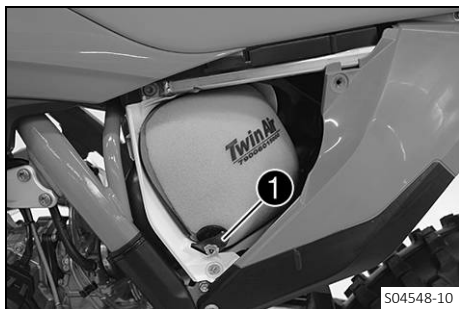

Preparatory work

- Remove the air filter box cover. (📖 p. 54)

Main work

- Detach retaining tab ①. Remove air filter with air filter support.
- Take off air filter from air filter support.

11.25 Cleaning the air filter and air filter box 🛠️



Note

Environmental hazard Hazardous substances cause environmental damage.

- Dispose of oils, grease, filters, fuel, cleaning agents, brake fluid, etc., correctly and in compliance with the applicable regulations.



Info

Do not clean the air filter with fuel or petroleum since these substances attack the foam.



Preparatory work

- Remove the air filter box cover. (📖 p. 54)
- Remove the air filter. 🛠️ (📖 p. 56)

Main work

- Wash the air filter thoroughly in special cleaning liquid and allow it to dry properly.

Air filter cleaner (📖 p. 122)



Info

Only press the air filter to dry it, never wring it out.

- Oil the dry air filter with a high-grade air filter oil.

Oil for foam air filter (📖 p. 122)

- Clean the air filter box.
- Clean the intake flange and check it for damage and tightness.

Finishing work

- Install the air filter. (🔧 p. 57)
- Install the air filter box cover. (🔧 p. 55)



11.26 Installing the air filter 🔧

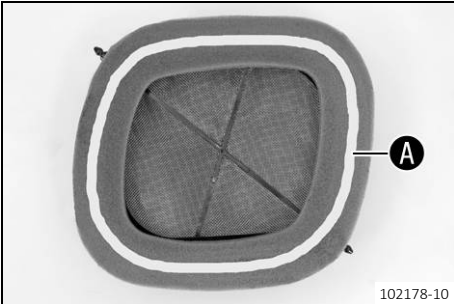

Main work

- Mount the clean air filter on the air filter support.
- Grease the air filter in area **A**.

Long-life grease (🔧 p. 122)

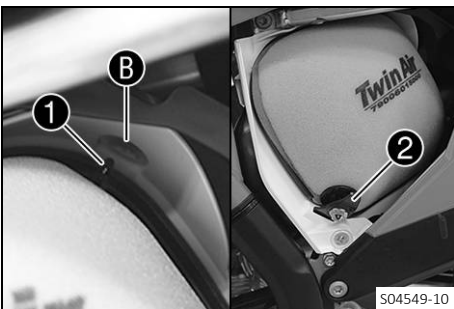

- Insert the air filter and position the top retaining pin **1** in bushing **B**.
 ✓ The air filter is correctly positioned.
- Secure the bottom retaining pin with holding tab **2**.

i Info

If the air filter is not mounted correctly, dust and dirt may enter the engine and result in damage.

Finishing work

- Install the air filter box cover. (🔧 p. 55)



11.27 Preparing air filter box cover for securing 🔧

Preparatory work

- Remove the air filter box cover. (🔧 p. 54)

Main work

- Drill a hole at marking **A**.

Guideline

Diameter	6 mm (0.24 in)
----------	----------------

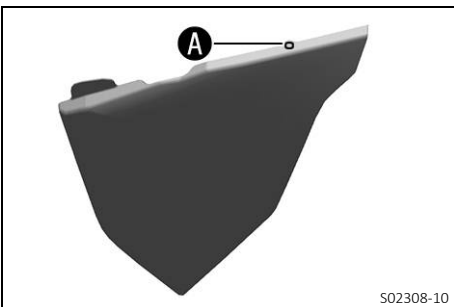

Finishing work

- Install the air filter box cover. (🔧 p. 55)



11.28 Removing the main silencer



Warning

Danger of burns The exhaust system gets very hot when the vehicle is driven.

- Allow the exhaust system to cool down before performing any work on the vehicle.



- Remove screws 1 with the washers.
- Pull off the main silencer from the manifold at exhaust sleeve 2.

11.29 Installing the main silencer

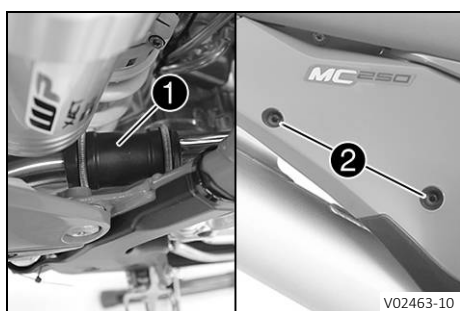

- Position the main silencer in exhaust sleeve 1.
- Mount and tighten screws 2 with the washers.

Guideline

Remaining screws, chassis	M6	10 Nm (7.4 lbf ft)
---------------------------	----	--------------------

11.30 Changing the glass fiber yarn filling in the main silencer



Warning

Danger of burns The exhaust system gets very hot when the vehicle is driven.

- Allow the exhaust system to cool down before performing any work on the vehicle.



Info

Over time, the fibers of the rock wool escape into the air, and the main silencer "burns out". Not only is the noise level higher, the performance characteristic changes.

Preparatory work

- Remove the main silencer. (📖 p. 58)

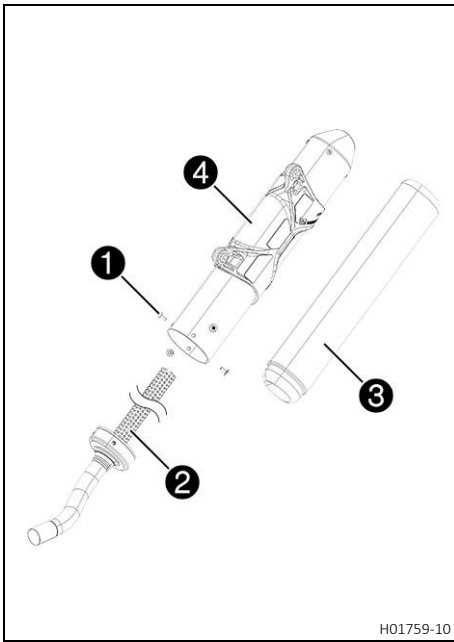

Main work

- Remove screws ①. Pull out inner tube ②.
- Remove the glass fiber yarn filling ③ from the inner tube.
- Clean the parts that need to be reinstalled and check for damage.
- Fit the new glass fiber yarn filling ③ into the inner tube.
- Slide outer tube ④ over the inner tube with the new glass fiber yarn filling.
- Mount and tighten all screws ①.

Guideline

Screws on main silencer	M5	7 Nm (5.2 lbf ft)
-------------------------	----	-------------------

Finishing work

- Install the main silencer. (🔧 p. 58)

11.31 Removing the fuel tank



Danger

Fire hazard Fuel is highly flammable.

The fuel in the fuel tank expands when warm and can escape if overfilled.

- Do not fuel the vehicle in the vicinity of open flames or lit cigarettes.
- Switch off the engine for refueling.
- Make sure that no fuel is spilled; particularly not on hot parts of the vehicle.
- If any fuel is spilled, wipe it off immediately.
- Observe the specifications for refueling.



Warning

Danger of poisoning Fuel is poisonous and a health hazard.

- Avoid skin, eye and clothing contact with fuel.
- Immediately consult a doctor if you swallow fuel.
- Do not inhale fuel vapors.
- In case of skin contact, rinse the affected area with plenty of water.
- Rinse the eyes thoroughly with water, and consult a doctor in case of fuel contact with the eyes.
- Change your clothing in case of fuel spills on them.
- Keep fuels correctly in a suitable canister, and out of the reach of children.

Preparatory work

- Remove the seat. (🔧 p. 53)
- Turn the knurled screw on the fuel tap all the way clockwise.

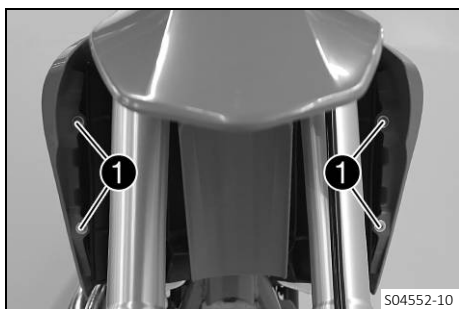

Main work

- Pull off the fuel hose.



Info

Remaining fuel may flow out of the fuel hose.

- Remove screws **1**.
- Remove screw **2** with the rubber bushing.
- Pull the fuel tank breather hose off the fuel tank lid.
- Pull both spoilers laterally off the radiator and take off the fuel tank upwards.

11.32 Installing the fuel tank



Danger

Fire hazard Fuel is highly flammable.

The fuel in the fuel tank expands when warm and can escape if overfilled.

- Do not fuel the vehicle in the vicinity of open flames or lit cigarettes.
- Switch off the engine for refueling.
- Make sure that no fuel is spilled; particularly not on hot parts of the vehicle.
- If any fuel is spilled, wipe it off immediately.
- Observe the specifications for refueling.



Warning

Danger of poisoning Fuel is poisonous and a health hazard.

- Avoid skin, eye and clothing contact with fuel.
- Immediately consult a doctor if you swallow fuel.
- Do not inhale fuel vapors.
- In case of skin contact, rinse the affected area with plenty of water.
- Rinse the eyes thoroughly with water, and consult a doctor in case of fuel contact with the eyes.
- Change your clothing in case of fuel spills on them.

Main work

- Check the throttle cable routing. (📖 p. 66)
- Position the fuel tank and fit the two spoilers laterally to the radiator.
- Make sure that no cables or throttle cables are trapped or damaged.

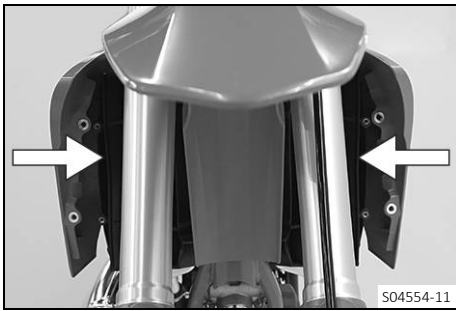

- Attach the fuel tank breather hose.
- Mount and tighten screw ① with the rubber bushing.

Guideline

Remaining screws, chassis	M6	10 Nm (7.4 lbf ft)
---------------------------	----	--------------------

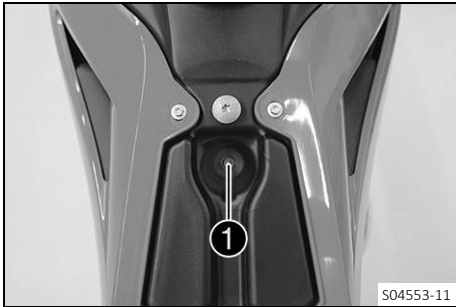

- Mount and tighten screws ②.

Guideline

Remaining screws, chassis	M6	10 Nm (7.4 lbf ft)
---------------------------	----	--------------------

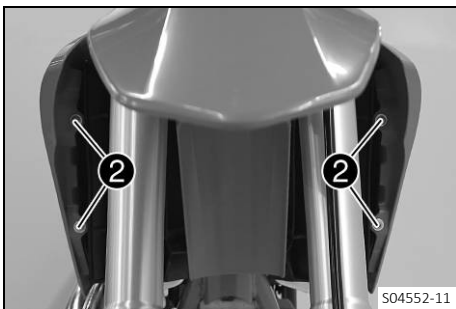

- Connect the fuel hose.

Finishing work

- Mount the seat. (📖 p. 54)

11.33 Checking the chain for dirt

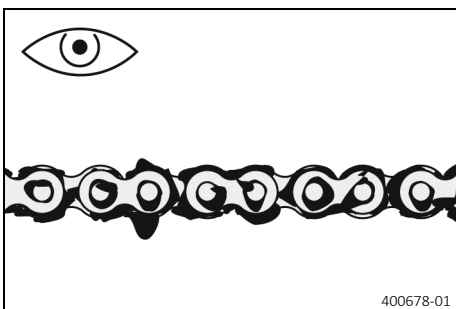

- Check the chain for heavy soiling.
 - » If the chain is very dirty:
 - Clean the chain. (📖 p. 62)

11.34 Cleaning the chain



Warning

- Danger of accidents** Lubricants on the tires reduces the road grip.
- Remove lubricants from the tires using a suitable cleaning agent.



Warning

- Danger of accidents** Oil or grease on the brake discs reduces the braking effect.
- Always keep the brake discs free of oil and grease.
 - Clean the brake discs with brake cleaner when necessary.



Note

- Environmental hazard** Hazardous substances cause environmental damage.
- Dispose of oils, grease, filters, fuel, cleaning agents, brake fluid, etc., correctly and in compliance with the applicable regulations.



Info

The service life of the chain depends largely on its maintenance.

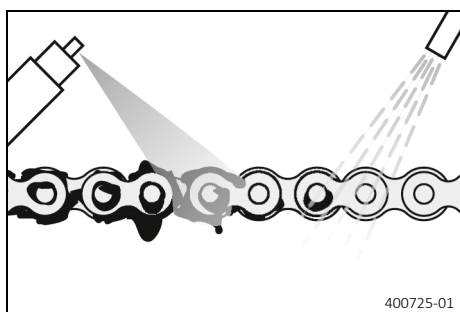

Preparatory work

- Raise the motorcycle with a lift stand. (📖 p. 42)

Main work

- Rinse off loose dirt with a soft jet of water.
- Remove old grease residue with chain cleaner.

Chain cleaner (📖 p. 122)

- After drying, apply chain spray.

Off-road chain spray (📖 p. 122)

Finishing work

- Remove the motorcycle from the lift stand. (📖 p. 42)

11.35 Checking the chain tension



Warning

Danger of accidents Incorrect chain tension damages components and results in accidents.

If the chain is tensioned too much, the chain, engine sprocket, rear sprocket, transmission and rear wheel bearings wear more quickly. Some components may break if overloaded.

If the chain is too loose, the chain may fall off the engine sprocket or the rear sprocket. As a result, the rear wheel locks or the engine will be damaged.

- Check the chain tension regularly.
- Set the chain tension in accordance with the specification.

Preparatory work

- Raise the motorcycle with a lift stand. (📖 p. 42)

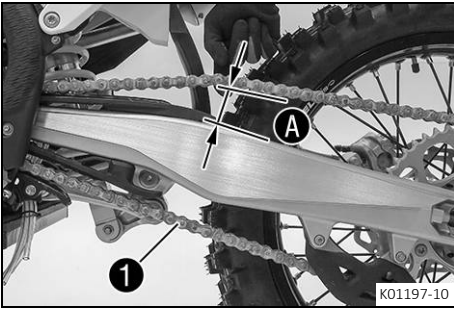

Main work

- Pull the chain at the end of the chain sliding piece upward to measure chain tension **A**.

Guideline

Lower chain section 1 must be taut.
--

i **Info**

Chain wear is not always even, so you should repeat this measurement at different chain positions.

Chain tension	55 ... 58 mm (2.17 ... 2.28 in)
---------------	---------------------------------

- » If the chain tension does not meet the specification:
 - Adjust the chain tension. (📖 p. 63)

Finishing work

- Remove the motorcycle from the lift stand. (📖 p. 42)

11.36 Adjusting the chain tension



Warning

Danger of accidents Incorrect chain tension damages components and results in accidents.

If the chain is tensioned too much, the chain, engine sprocket, rear sprocket, transmission and rear wheel bearings wear more quickly. Some components may break if overloaded.

If the chain is too loose, the chain may fall off the engine sprocket or the rear sprocket. As a result, the rear wheel locks or the engine will be damaged.

- Check the chain tension regularly.
- Set the chain tension in accordance with the specification.

Preparatory work

- Raise the motorcycle with a lift stand. (📖 p. 42)
- Check the chain tension. (📖 p. 62)

Main work

- Loosen nut **1**.
- Loosen nuts **2**.
- Adjust the chain tension by turning adjusting screws **3** left and right.

Guideline

Chain tension	55 ... 58 mm (2.17 ... 2.28 in)
Turn adjusting screws 3 on the left and right so that the markings on the left and right chain adjusters are in the same position relative to reference marks A . The rear wheel is then correctly aligned.	

- Tighten nuts **2**.
- Make sure that chain adjusters **4** are fitted correctly on adjusting screws **3**.
- Tighten nut **1**.

Guideline

Nut, rear wheel spindle	M25x1.5	80 Nm (59 lbf ft)
-------------------------	---------	-------------------

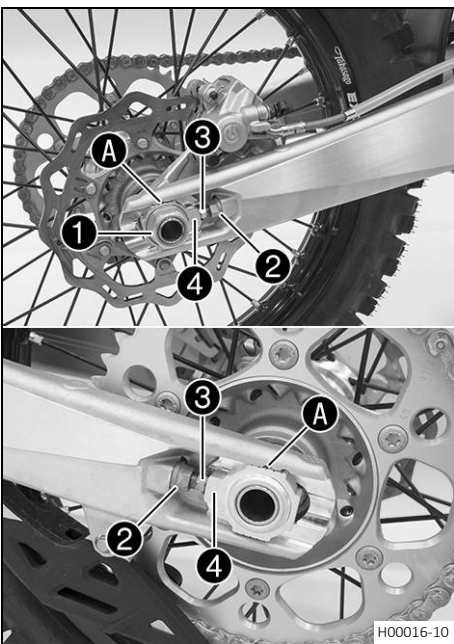



Info

The wide adjustment range of the chain adjusters (32 mm (1.26 in)) enables different secondary ratios with the same chain length.

Chain adjusters ④ can be turned by 180°.

Finishing work

- Remove the motorcycle from the lift stand. (📖 p. 42)

11.37 Checking the chain, rear sprocket, engine sprocket, and chain guide

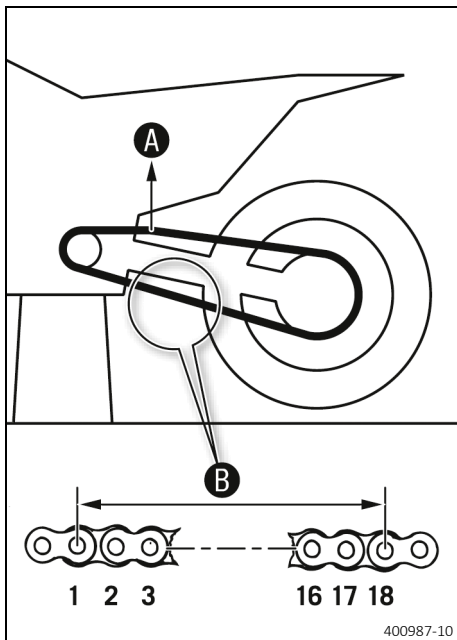
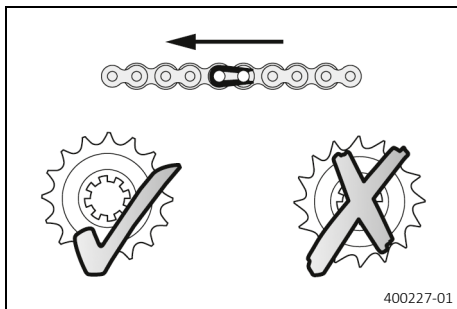

Preparatory work

- Raise the motorcycle with a lift stand. (📖 p. 42)

Main work

- Shift the transmission into neutral.
- Check the chain, rear sprocket and engine sprocket for wear.
 - » If the chain, rear sprocket or engine sprocket is worn:
 - Change the drivetrain kit. 🛠️



Info

The engine sprocket, rear sprocket and chain should always be replaced together.

- Pull on the top section of the chain with the specified weight ①.

Guideline

Weight, chain wear measurement	10 ... 15 kg (22 ... 33 lb.)
--------------------------------	------------------------------

- Measure distance ② of 18 chain rollers in the lower chain section.



Info

Chain wear is not always even, so you should repeat this measurement at different chain positions.

Maximum distance ② from 18 chain rollers at the longest chain section	272 mm (10.71 in)
---	-------------------

- » If distance ② is greater than the specified measurement:

- Change the drivetrain kit. 🛠️



Info

When a new chain is mounted, the rear sprocket and the engine sprocket should also be changed. New chains wear out faster on an old, worn rear sprocket or engine sprocket.

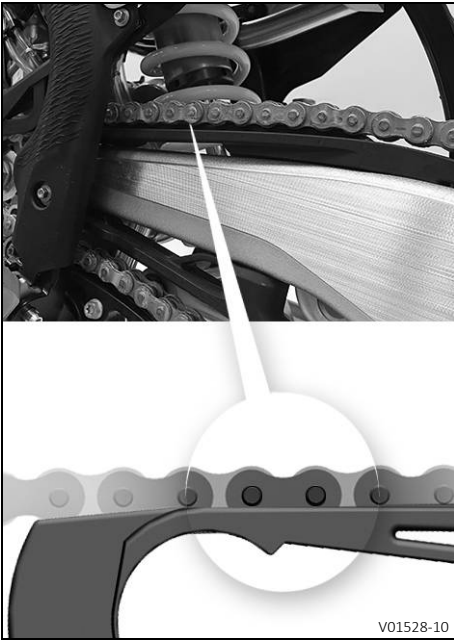

- Check the chain sliding guard for wear.
 - » If the lower edge of the chain pins is in line with, or below, the chain sliding guard:
 - Change the chain sliding guard. 🛠️
- Check that the chain sliding guard is firmly seated.
 - » If the chain sliding guard is loose:
 - Tighten screws on the chain sliding guard.

Guideline

Screw, chain sliding guard	M6	6 Nm (4.4 lbf ft) Loctite®243™
----------------------------	----	--

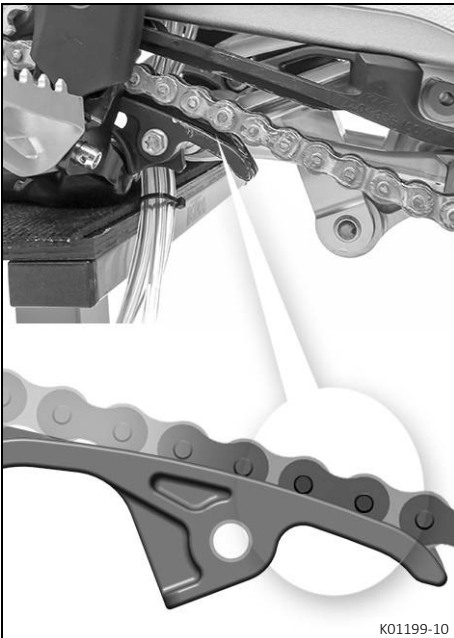

- Check the chain sliding piece for wear.
 - » If the lower edge of the chain pins is in line with or below the chain sliding piece:
 - Change the chain sliding piece. 🛠️
- Check that the chain sliding piece is firmly seated.
 - » If the chain sliding piece is loose:
 - Tighten screw on the chain sliding piece.

Guideline

Screw, chain sliding piece	M8	15 Nm (11.1 lbf ft)
----------------------------	----	---------------------

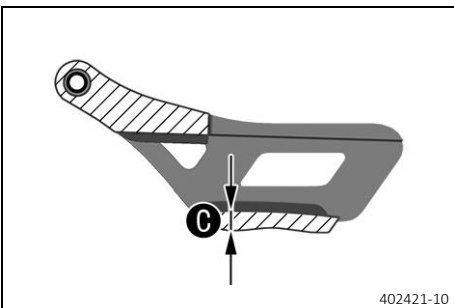

- Check the chain guide with a slide gage for dimension **C**.

Minimum thickness C of the chain guide	6 mm (0.24 in)
---	----------------

- » If the measured value is less than the specified value:
 - Change the chain guide. 🛠️

11 SERVICE WORK ON THE CHASSIS



- Check that the chain guide is firmly seated.
 - » If the chain guide is loose:
 - Tighten the screws on the chain guide.

Guideline

Screw, chain guide	M6	10 Nm (7.4 lbf ft)
Screw, chain guide on link fork at the rear	M6	10 Nm (7.4 lbf ft) Loctite®243™

Finishing work

- Remove the motorcycle from the lift stand. (📖 p. 42)

11.38 Checking the frame 🛠️

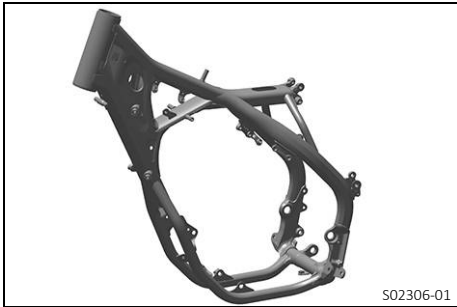

- Check the frame for damage, cracks, and deformation.
 - » If the frame shows signs of damage, cracks, or deformation:
 - Change the frame. 🛠️

Guideline

Repairs on the frame are not permitted.

11.39 Checking the link fork 🛠️



- Check the link fork for damage, cracks, and deformation.
 - » If the link fork shows signs of damage, cracks, or deformation:
 - Change the link fork. 🛠️

Guideline

Repairs on the link fork are not permitted.

11.40 Checking the throttle cable routing



Warning

Danger of accidents The throttle cable may slip out of the guide if routed incorrectly. The throttle slide will then no longer be closed and the speed can no longer be controlled.

- Make sure that the throttle cable routing and the play in throttle cable complies with the specification.

Preparatory work

- Remove the seat. (📖 p. 53)
- Turn the knurled screw on the fuel tap all the way clockwise.
- Remove the fuel tank. 🛠️ (📖 p. 59)

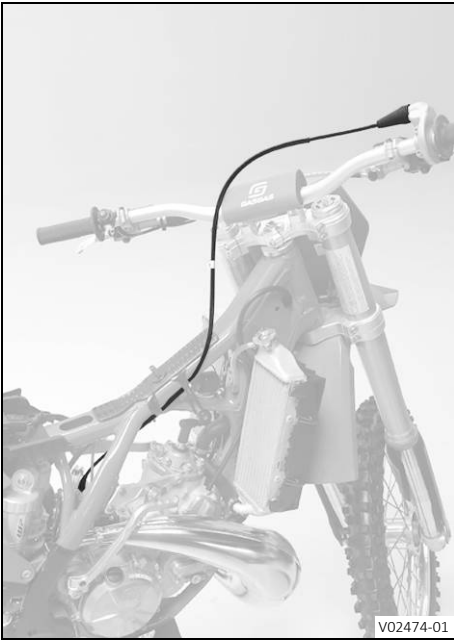

V02474-01

Main work

- Check the throttle cable routing.

The throttle cable must be routed along the back of the handlebar, to the right of the frame, above the fuel tank bracket, and to the carburetor. The throttle cable must be secured on the fuel tank bracket with a rubber strap.

- » If the throttle cable is not routed as specified:
 - Correct the throttle cable routing.

Finishing work

- Install the fuel tank. (🔧 p. 60)
- Mount the seat. (📖 p. 54)



11.41 Checking the rubber grip

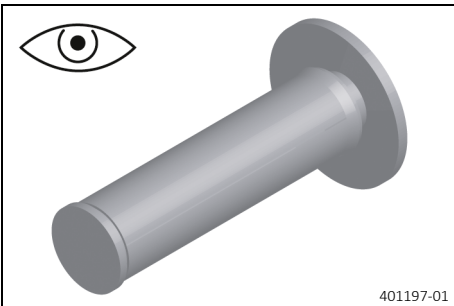

401197-01

- Check the rubber grips on the handlebar for damage, wear, and looseness.

i Info
 The rubber grips are vulcanized onto a sleeve on the left and onto the handle tube of the throttle grip on the right. The left sleeve is clamped onto the handlebar. The rubber grip can only be replaced with the sleeve or the throttle tube.

- » If a rubber grip is damaged or worn:
 - Change the rubber grip.

- Check that screw ① is firmly seated.

Guideline

Screw, fixed grip	M4	5 Nm (3.7 lbf ft) Loctite® 243™
-------------------	----	---

Diamond ② must be located at the top.

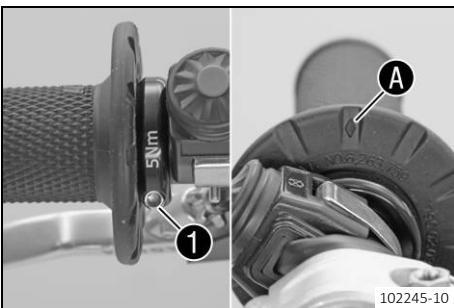

102245-10

11.42 Adjusting the basic position of the clutch lever

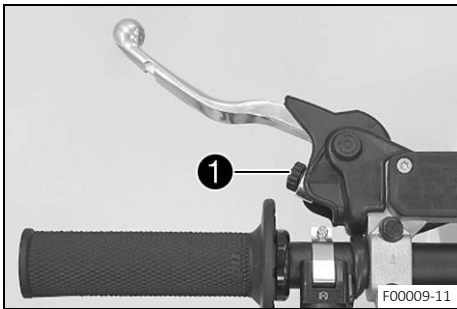

- Adjust the basic position of the clutch lever to your hand size by turning adjusting screw **1**.



Info

Turn the adjusting screw counterclockwise to decrease the distance between the clutch lever and the handlebar. Turn the adjusting screw clockwise to increase the distance between the clutch lever and the handlebar. The range of adjustment is limited. Turn the adjusting screw by hand only, and do not apply any force. Do not make any adjustments while riding.

11.43 Checking/correcting the fluid level of the hydraulic clutch



Warning

Skin irritation Brake fluid causes skin irritation.

- Keep brake fluid out of the reach of children.
- Wear suitable protective clothing and safety glasses.
- Do not allow brake fluid to come into contact with the skin, the eyes or clothing.
- Consult a doctor immediately if brake fluid has been swallowed.
- Rinse the affected area with plenty of water in the event of contact with the skin.
- Rinse eyes thoroughly with water immediately and consult a doctor if brake fluid comes into contact with the eyes.
- If brake fluid spills on to your clothing, change the clothing.



Info

The fluid level rises with increasing wear of the clutch facing discs. Never use DOT 5 brake fluid. It is silicone-based and purple in color. Oil seals and clutch lines are not designed for DOT 5 brake fluid. Avoid contact between brake fluid and painted parts. Brake fluid attacks paint. Only use clean brake fluid from a sealed container.

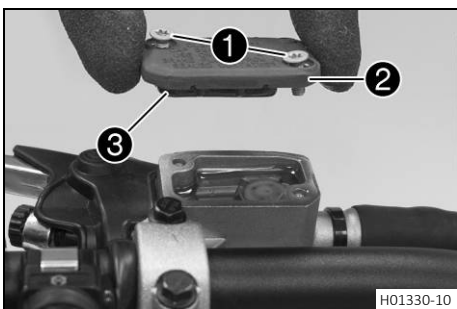

- Move the clutch fluid reservoir mounted on the handlebar to a horizontal position.
- Remove screws **1**.
- Remove cover **2** with membrane **3**.
- Check the fluid level.

Fluid level below container rim	4 mm (0.16 in)
---------------------------------	----------------

- » If the fluid level does not meet specifications:
 - Correct the fluid level of the hydraulic clutch.

Brake fluid DOT 4 / DOT 5.1 (📖 p. 120)
--

- Position the cover with the membrane. Mount and tighten the screws.



Info

Clean up overflowed or spilled brake fluid immediately with water.

11.44 Changing the hydraulic clutch fluid



Warning

Skin irritation Brake fluid causes skin irritation.

- Keep brake fluid out of the reach of children.
- Wear suitable protective clothing and safety glasses.
- Do not allow brake fluid to come into contact with the skin, the eyes or clothing.
- Consult a doctor immediately if brake fluid has been swallowed.
- Rinse the affected area with plenty of water in the event of contact with the skin.
- Rinse eyes thoroughly with water immediately and consult a doctor if brake fluid comes into contact with the eyes.
- If brake fluid spills on to your clothing, change the clothing.



Note

Environmental hazard Hazardous substances cause environmental damage.

- Dispose of oils, grease, filters, fuel, cleaning agents, brake fluid, etc., correctly and in compliance with the applicable regulations.



Info

Never use DOT 5 brake fluid. It is silicone-based and purple in color. Oil seals and clutch lines are not designed for DOT 5 brake fluid.

Avoid contact between brake fluid and painted parts. Brake fluid attacks paint.

Only use clean brake fluid from a sealed container.

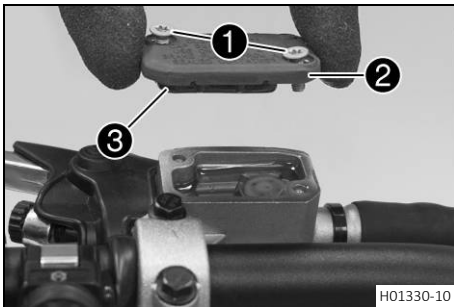

- Move the clutch fluid reservoir mounted on the handlebar to a horizontal position.
- Remove screws ①.
- Remove cover ② with membrane ③.

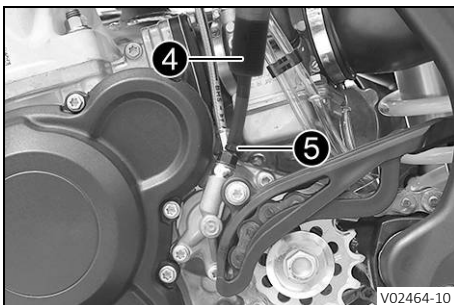

- Fill bleeding syringe ④ with the appropriate hydraulic fluid.

Syringe (50329050000)

Brake fluid DOT 4 / DOT 5.1 (📖 p. 120)
--

- On the clutch slave cylinder, remove bleeder screw ⑤ and mount bleeding syringe ④.

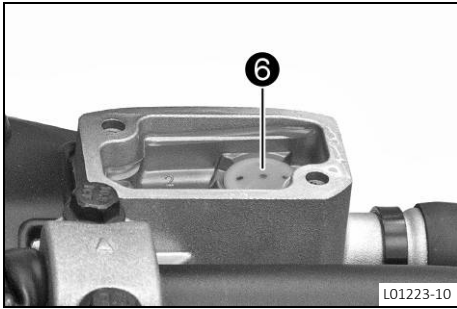

- Now inject the liquid into the system until it emerges from the drill hole ⑥ of the master cylinder without bubbles.
- Now and then, extract fluid from the master cylinder reservoir to prevent overflow.
- Remove the bleeding syringe. Mount and tighten screws bleeder screw.
- Correct the fluid level of the hydraulic clutch.

Guideline

Fluid level below container rim	4 mm (0.16 in)
---------------------------------	----------------

- Position the cover with the membrane. Mount and tighten the screws.



Info

Clean up overflowed or spilled brake fluid immediately with water.

12.1 Checking the free travel of the hand brake lever



Warning

Danger of accidents The brake system fails in the event of overheating.

If there is no free travel on the hand brake lever, pressure builds up on the front brake circuit.

- Set the free travel on the hand brake lever in accordance with the specification.

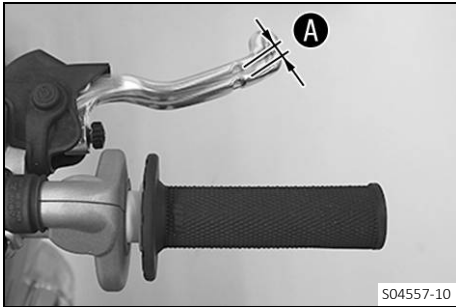

- Push the hand brake lever forward and check free travel **A**.

Free travel of hand brake lever	≥ 3 mm (≥ 0.12 in)
---------------------------------	--------------------

- » If the free travel does not match the specification:
 - Adjust the basic position of the hand brake lever. (🔧 p. 71)

12.2 Adjusting the basic position of the hand brake lever

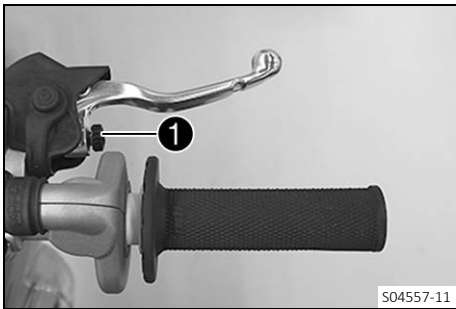

- Check the free travel of the hand brake lever. (🔧 p. 71)
- Adjust the basic position of the hand brake lever to your hand size by turning adjusting screw **1**.



Info

Turn the adjusting screw clockwise to increase the distance between the hand brake lever and the handlebar. Turn the adjusting screw counterclockwise to decrease the distance between the hand brake lever and the handlebar. The range of adjustment is limited. Only turn the adjusting screw by hand, and do not use force. Do not make any adjustments while riding.

12.3 Checking the brake discs



Warning

Danger of accidents Worn-out brake discs reduce the braking effect.

- Make sure that worn-out brake discs are replaced immediately. (Your authorized GASGAS Motorcycles workshop will be glad to help.)

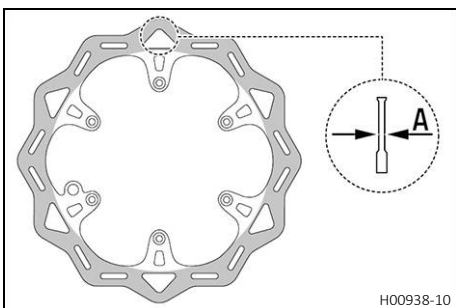

- Check the front and rear brake disc thickness at multiple points for the dimension **A**.



Info

Wear reduces the thickness of the brake disc around the contact surface of the brake linings.

Brake discs - wear limit	
front	2.5 mm (0.098 in)
rear	3.5 mm (0.138 in)

- » If the brake disc thickness is less than the specified value:

- Change the front brake disc. 🛠️
- Change the rear brake disc. 🛠️
- Check the front and rear brake discs for damage, cracking, and deformation.
 - » If the brake disc exhibits damage, cracking, or deformation:
 - Change the front brake disc. 🛠️
 - Change the rear brake disc. 🛠️

12.4 Checking the front brake fluid level



Warning

Danger of accidents An insufficient brake fluid level will cause the brake system to fail.

If the brake fluid level drops below the specified marking or the specified value, the brake system is leaking or the brake linings are worn down.

- Check the brake system and do not continue riding until the problem is eliminated. (Your authorized GAS-GAS Motorcycles workshop will be glad to help.)



Warning

Danger of accidents Old brake fluid reduces the braking effect.

- Make sure that brake fluid for the front and rear brake is changed in accordance with the service schedule. (Your authorized GASGAS Motorcycles workshop will be glad to help.)

Preparatory work

- Check the front brake linings. (📖 p. 74)

Main work

- Move the brake reservoir mounted on the handlebar to a horizontal position.
- Check the brake fluid level in level viewer **1**.
 - » If the brake fluid level has dropped below the marking **A**:
 - Add front brake fluid. 🛠️ (📖 p. 72)

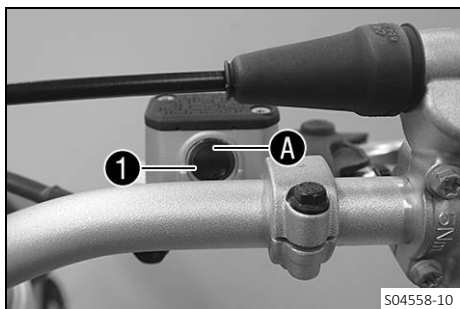

12.5 Adding front brake fluid 🛠️



Warning

Danger of accidents An insufficient brake fluid level will cause the brake system to fail.

If the brake fluid level drops below the specified marking or the specified value, the brake system is leaking or the brake linings are worn down.

- Check the brake system and do not continue riding until the problem is eliminated. (Your authorized GAS-GAS Motorcycles workshop will be glad to help.)



Warning

Skin irritation Brake fluid causes skin irritation.

- Keep brake fluid out of the reach of children.
- Wear suitable protective clothing and safety glasses.
- Do not allow brake fluid to come into contact with the skin, the eyes or clothing.
- Consult a doctor immediately if brake fluid has been swallowed.
- Rinse the affected area with plenty of water in the event of contact with the skin.
- Rinse eyes thoroughly with water immediately and consult a doctor if brake fluid comes into contact with the eyes.
- If brake fluid spills on to your clothing, change the clothing.



Warning

Danger of accidents Old brake fluid reduces the braking effect.

- Make sure that brake fluid for the front and rear brake is changed in accordance with the service schedule. (Your authorized GASGAS Motorcycles workshop will be glad to help.)



Note

Environmental hazard Hazardous substances cause environmental damage.

- Dispose of oils, grease, filters, fuel, cleaning agents, brake fluid, etc., correctly and in compliance with the applicable regulations.



Info

Never use DOT 5 brake fluid. It is silicone-based and purple in color. Oil seals and brake lines are not designed for DOT 5 brake fluid.
 Avoid contact between brake fluid and painted parts. Brake fluid attacks paint.
 Only use clean brake fluid from a sealed container.

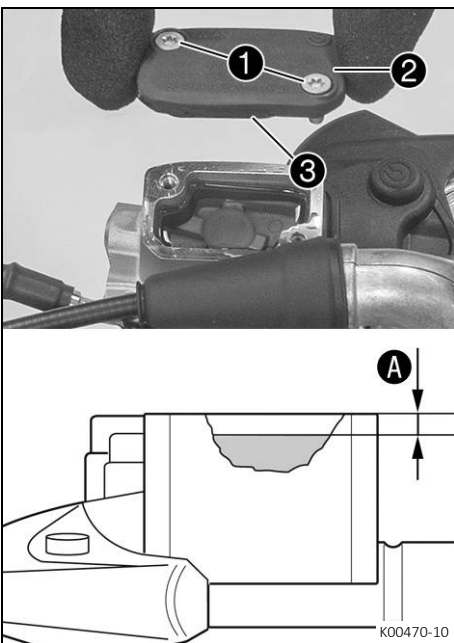

Preparatory work

- Check the front brake linings. (📖 p. 74)

Main work

- Move the brake reservoir mounted on the handlebar to a horizontal position.
- Remove screws ①.
- Take off cover ② with membrane ③.
- Add brake fluid to level A.

Guideline

Level A (brake fluid level below reservoir rim)	5 mm (0.2 in)
---	---------------

Brake fluid DOT 4 / DOT 5.1 (📖 p. 120)

- Position the cover with the membrane. Mount and tighten the screws.



Info

Clean up overflowed or spilled brake fluid immediately with water.

12.6 Checking the front brake linings



Warning

Danger of accidents Worn-out brake linings reduce the braking effect.

- Ensure that worn-out brake linings are replaced immediately. (Your authorized GASGAS Motorcycles workshop will be glad to help.)

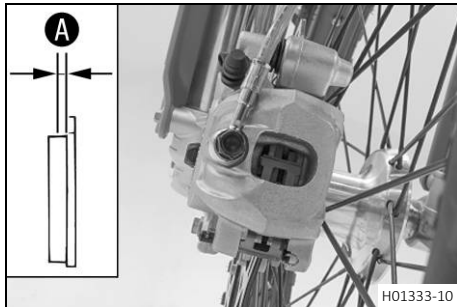

- Check the brake linings for minimum thickness **A**.

Minimum thickness A	$\geq 1 \text{ mm } (\geq 0.04 \text{ in})$
----------------------------	---

- » If the minimum thickness is less than specified:
 - Change the brake linings of the front brake. 🛠️ (p. 74)
- Check the brake linings for damage and cracking.
 - » If damage or wear is encountered:
 - Change the brake linings of the front brake. 🛠️ (p. 74)

12.7 Changing the brake linings of the front brake 🛠️



Warning

Danger of accidents Incorrect servicing will cause the brake system to fail.

- Ensure that service work and repairs are performed professionally. (Your authorized GASGAS Motorcycles workshop will be glad to help.)



Warning

Skin irritation Brake fluid causes skin irritation.

- Keep brake fluid out of the reach of children.
- Wear suitable protective clothing and safety glasses.
- Do not allow brake fluid to come into contact with the skin, the eyes or clothing.
- Consult a doctor immediately if brake fluid has been swallowed.
- Rinse the affected area with plenty of water in the event of contact with the skin.
- Rinse eyes thoroughly with water immediately and consult a doctor if brake fluid comes into contact with the eyes.
- If brake fluid spills on to your clothing, change the clothing.



Warning

Danger of accidents Old brake fluid reduces the braking effect.

- Make sure that brake fluid for the front and rear brake is changed in accordance with the service schedule. (Your authorized GASGAS Motorcycles workshop will be glad to help.)



Warning

Danger of accidents Oil or grease on the brake discs reduces the braking effect.

- Always keep the brake discs free of oil and grease.
- Clean the brake discs with brake cleaner when necessary.



Warning

Danger of accidents Brake linings which have not been approved alter the braking efficiency.

Not all brake linings are tested and approved for GASGAS motorcycles. The structure and friction coefficient of the brake linings, and thus their brake power, may vary greatly from that of original brake linings.

If brake linings are used that differ from the original equipment, compliance with the original homologation is not guaranteed. In this case, the vehicle no longer corresponds to its condition at delivery and the manufacturer warranty shall be void.

- Only use brake linings approved and recommended by GASGAS Motorcycles.



Note

Environmental hazard Hazardous substances cause environmental damage.

- Dispose of oils, grease, filters, fuel, cleaning agents, brake fluid, etc., correctly and in compliance with the applicable regulations.



Info

Never use DOT 5 brake fluid. It is silicone-based and purple in color. Oil seals and brake lines are not designed for DOT 5 brake fluid.

Avoid contact between brake fluid and painted parts. Brake fluid corrodes paint.

Only use clean brake fluid from a sealed container.

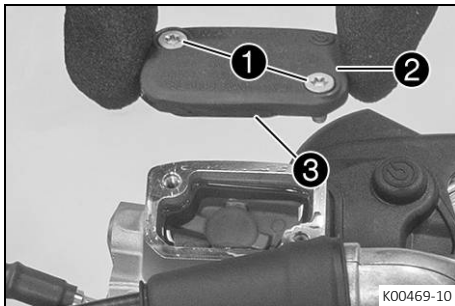

- Move the brake fluid reservoir mounted on the handlebar to a horizontal position.
- Remove screws **1**.
- Take off cover **2** with membrane **3**.
- Manually press the brake caliper toward the brake disc to push back the brake pistons. Ensure that brake fluid does not flow out of the brake fluid reservoir, extract some if necessary.



Info

Make sure that you do not press the brake caliper against the spokes when pushing back the brake pistons.

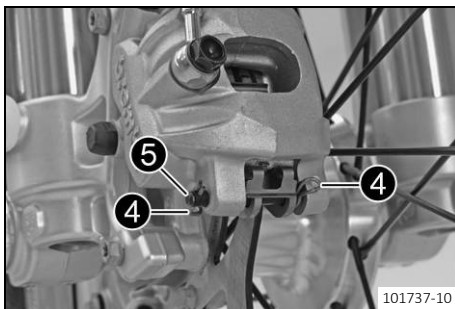

- Remove cotter pins **4**, pull out pin **5**, and remove the brake linings.
- Clean the brake caliper and the brake caliper bracket.

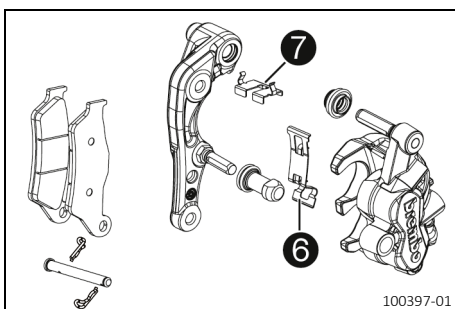

- Check that spring plate **6** in the brake caliper and brake pad sliding plate **7** in the brake caliper bracket are seated correctly.

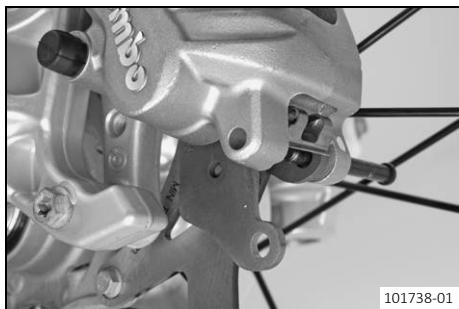

- Insert the new brake linings, insert pin, and mount cotter pins.



Info

Always change the brake linings in pairs.

- Operate the hand brake lever repeatedly until the brake linings are in contact with the brake disc and there is a pressure point.

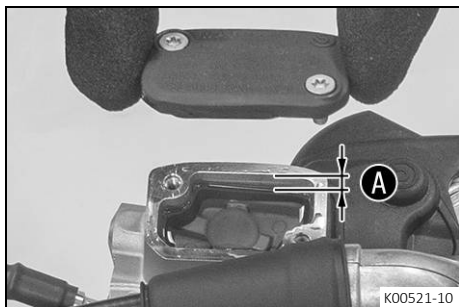

- Correct the brake fluid level to level **A**.

Guideline

Level A (brake fluid level below reservoir rim)	5 mm (0.2 in)
--	---------------

Brake fluid DOT 4 / DOT 5.1 (📖 p. 120)
--

- Position the cover with the membrane. Mount and tighten the screws.



Info

Use water to immediately clean up any brake fluid that has overflowed or spilled.

12.8 Checking the free travel of foot brake lever



Warning

Danger of accidents The brake system fails in the event of overheating.

If there is no free travel on the foot brake lever, pressure builds up in the brake system on the rear brake.

- Set the free travel on the foot brake lever in accordance with the specification.

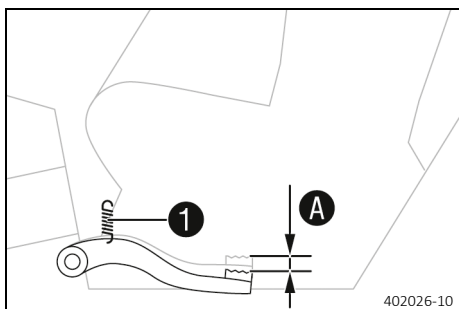

- Disconnect spring **1**.
- Move the foot brake lever back and forth between the end stop and the contact to the foot brake cylinder piston and check free travel **A**.

Guideline

Free travel at foot brake lever	3 ... 5 mm (0.12 ... 0.2 in)
---------------------------------	------------------------------

» If the free travel does not meet specifications:

- Adjust the basic position of the foot brake lever. 🛠️ (📖 p. 77)

- Reconnect spring **1**.

12.9 Adjusting the basic position of the foot brake lever



Warning

Danger of accidents The brake system fails in the event of overheating.
 If there is no free travel on the foot brake lever, pressure builds up in the brake system on the rear brake.
 – Set the free travel on the foot brake lever in accordance with the specification.

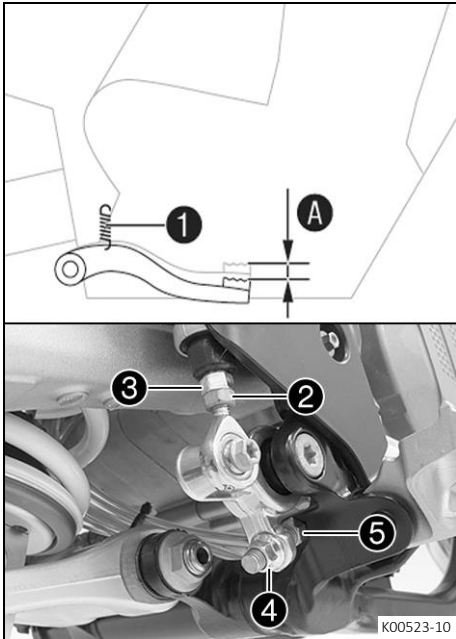

- Detach spring ①.
- Loosen nut ② and, with push rod ③, turn it back until you have maximum free travel.
- To adjust the basic position of the foot brake lever to individual requirements, loosen nut ④ and turn screw ⑤ accordingly.



Info
 The range of adjustment is limited.

- Turn push rod ③ accordingly until you have free travel A. If necessary, adjust the basic position of the foot brake lever.

Guideline

Free travel at foot brake lever	3 ... 5 mm (0.12 ... 0.2 in)
---------------------------------	------------------------------

- Hold screw ⑤ and tighten nut ④.

Guideline

Nut, foot brake lever stop	M8	20 Nm (14.8 lbf ft)
----------------------------	----	---------------------

- Hold push rod ③ and tighten nut ②.

Guideline

Remaining nuts, chassis	M6	10 Nm (7.4 lbf ft)
-------------------------	----	--------------------

- Attach spring ①.



12.10 Checking the rear brake fluid level



Warning

Danger of accidents An insufficient brake fluid level will cause the brake system to fail.
 If the brake fluid level drops below the specified marking or the specified value, the brake system is leaking or the brake linings are worn down.
 – Check the brake system and do not continue riding until the problem is eliminated. (Your authorized GAS-GAS Motorcycles workshop will be glad to help.)



Warning

Danger of accidents Old brake fluid reduces the braking effect.
 – Make sure that brake fluid for the front and rear brake is changed in accordance with the service schedule. (Your authorized GASGAS Motorcycles workshop will be glad to help.)

Preparatory work

- Check the brake linings of the rear brake. (📖 p. 79)

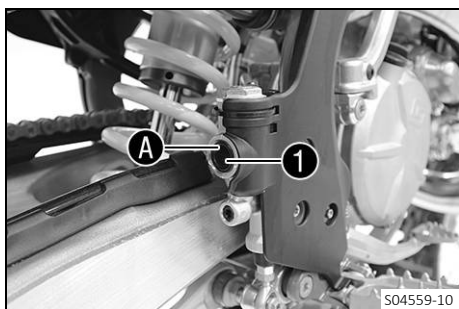

Main work

- Stand the vehicle upright.
- Check the brake fluid level in level viewer **1**.
 - » If the brake fluid has dropped below marking **A**:
 - Add rear brake fluid. (📖 p. 78)

12.11 Adding rear brake fluid 🛠️



Warning

Danger of accidents An insufficient brake fluid level will cause the brake system to fail.

If the brake fluid level drops below the specified marking or the specified value, the brake system is leaking or the brake linings are worn down.

- Check the brake system and do not continue riding until the problem is eliminated. (Your authorized GAS-GAS Motorcycles workshop will be glad to help.)



Warning

Skin irritation Brake fluid causes skin irritation.

- Keep brake fluid out of the reach of children.
- Wear suitable protective clothing and safety glasses.
- Do not allow brake fluid to come into contact with the skin, the eyes or clothing.
- Consult a doctor immediately if brake fluid has been swallowed.
- Rinse the affected area with plenty of water in the event of contact with the skin.
- Rinse eyes thoroughly with water immediately and consult a doctor if brake fluid comes into contact with the eyes.
- If brake fluid spills on to your clothing, change the clothing.



Warning

Danger of accidents Old brake fluid reduces the braking effect.

- Make sure that brake fluid for the front and rear brake is changed in accordance with the service schedule. (Your authorized GASGAS Motorcycles workshop will be glad to help.)



Note

Environmental hazard Hazardous substances cause environmental damage.

- Dispose of oils, grease, filters, fuel, cleaning agents, brake fluid, etc., correctly and in compliance with the applicable regulations.



Info

Never use DOT 5 brake fluid. It is silicone-based and purple in color. Oil seals and brake lines are not designed for DOT 5 brake fluid.

Avoid contact between brake fluid and painted parts. Brake fluid attacks paint.

Only use clean brake fluid from a sealed container.

Preparatory work

- Check the brake linings of the rear brake. (📖 p. 79)

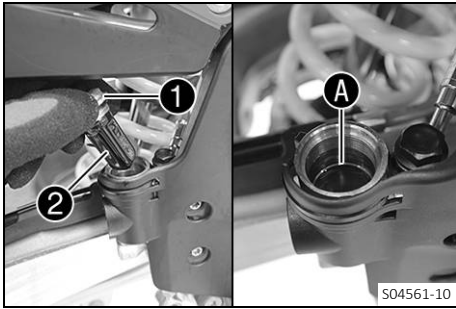

Main work

- Stand the vehicle upright.
- Remove screw cap ① with membrane ② and the O-ring.
- Add brake fluid to level A.

Brake fluid DOT 4 / DOT 5.1 (📖 p. 120)

- Mount the screw cap with the membrane and the O-ring.

i Info
Clean up overflowed or spilled brake fluid immediately with water.

12.12 Checking the brake linings of the rear brake

! Warning
Danger of accidents Worn-out brake linings reduce the braking effect.

- Ensure that worn-out brake linings are replaced immediately. (Your authorized GASGAS Motorcycles workshop will be glad to help.)

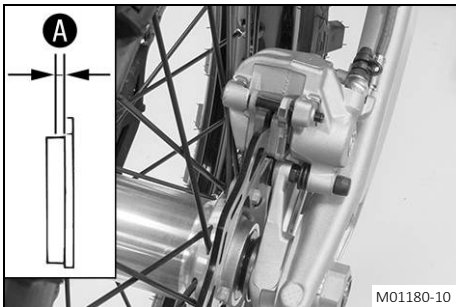

- Check the brake linings for minimum thickness A.

Minimum thickness A $\geq 1 \text{ mm } (\geq 0.04 \text{ in})$

- » If the minimum thickness is less than specified:
 - Change the rear brake linings. 🛠️ (📖 p. 79)
- Check the brake linings for damage and cracking.
 - » If damage or wear is encountered:
 - Change the rear brake linings. 🛠️ (📖 p. 79)

12.13 Changing the rear brake linings 🛠️

! Warning
Danger of accidents Incorrect servicing will cause the brake system to fail.

- Ensure that service work and repairs are performed professionally. (Your authorized GASGAS Motorcycles workshop will be glad to help.)

! Warning
Skin irritation Brake fluid causes skin irritation.

- Keep brake fluid out of the reach of children.
- Wear suitable protective clothing and safety glasses.
- Do not allow brake fluid to come into contact with the skin, the eyes or clothing.
- Consult a doctor immediately if brake fluid has been swallowed.
- Rinse the affected area with plenty of water in the event of contact with the skin.
- Rinse eyes thoroughly with water immediately and consult a doctor if brake fluid comes into contact with the eyes.
- If brake fluid spills on to your clothing, change the clothing.



Warning

Danger of accidents Old brake fluid reduces the braking effect.

- Make sure that brake fluid for the front and rear brake is changed in accordance with the service schedule. (Your authorized GASGAS Motorcycles workshop will be glad to help.)



Note

Environmental hazard Hazardous substances cause environmental damage.

- Dispose of oils, grease, filters, fuel, cleaning agents, brake fluid, etc., correctly and in compliance with the applicable regulations.



Info

Never use DOT 5 brake fluid. It is silicone-based and purple in color. Oil seals and brake lines are not designed for DOT 5 brake fluid.

Avoid contact between brake fluid and painted parts. Brake fluid corrodes paint.

Only use clean brake fluid from a sealed container.

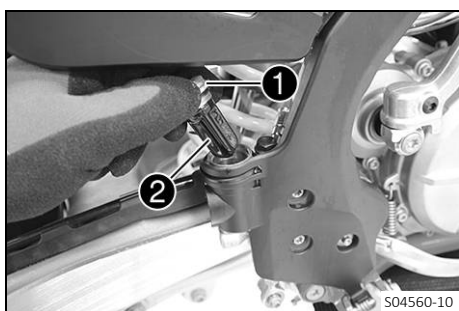

- Position the vehicle vertically.
- Remove screw cap ① with membrane ② and the O-ring.

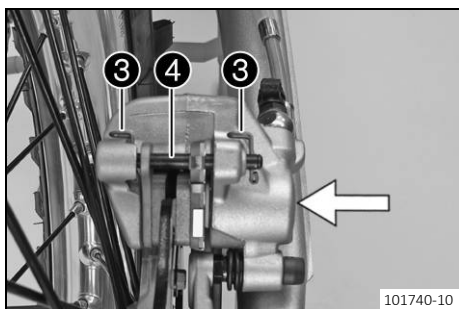

- Manually press the brake caliper toward the brake disc to push back the brake piston. Ensure that brake fluid does not flow out of the brake fluid reservoir; extract some if necessary.



Info

Make sure that you do not press the brake caliper against the spokes when pushing back the brake piston.

- Remove cotter pins ③, pull out pin ④, and remove the brake linings.
- Clean the brake caliper and the brake caliper bracket.
- Check that spring plate ⑤ in the brake caliper and brake pad sliding plate ⑥ in the brake caliper bracket are seated correctly.

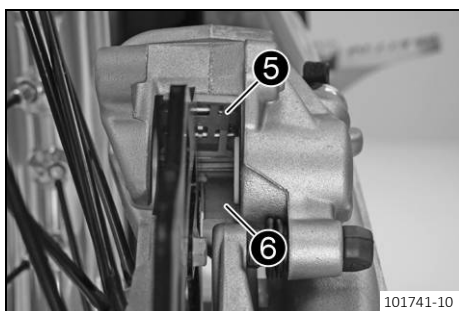

Info

The arrow on the spring plate points in the direction of rotation of the brake disc.

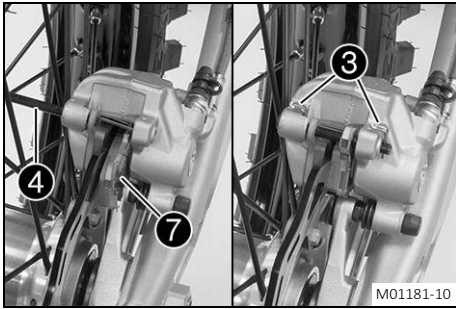

- Insert the new brake linings, insert pin **4**, and mount cotter pins **3**.

**Info**

Always change the brake linings in pairs.

Make sure that decoupling plate **7** is mounted on the piston side brake lining.

- Operate the foot brake lever repeatedly until the brake linings are in contact with the brake disc and there is a pressure point.

- Correct brake fluid level to marking **A**.

Brake fluid DOT 4 / DOT 5.1 (📖 p. 120)

- Mount and tighten screw cap **1** with membrane **2** and the O-ring.

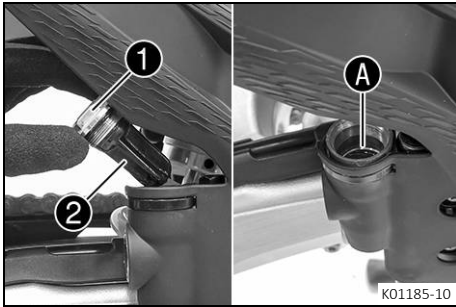
**Info**

Use water to immediately clean up any brake fluid that has overflowed or spilled.



13.1 Removing the front wheel

Preparatory work

- Raise the motorcycle with a lift stand. (📖 p. 42)

Main work

- Manually press the brake caliper toward the brake disc to push back the brake pistons.

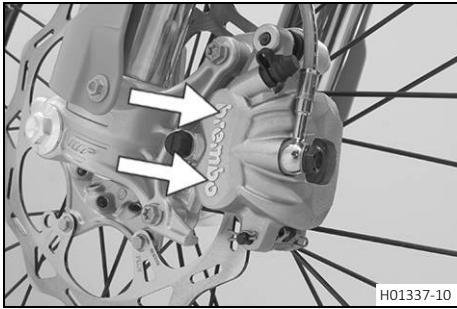

Info

Make sure that you do not press the brake caliper against the spokes when pushing back the brake pistons.

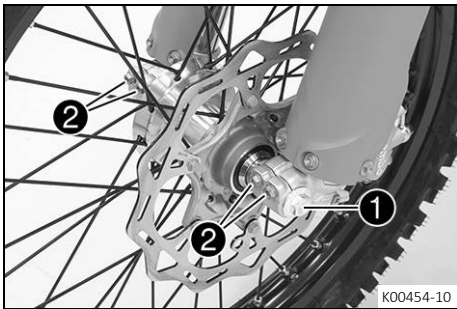

- Loosen screw **1** by several rotations.
- Loosen screws **2**.
- Press on screw **1** to push the wheel spindle out of the axle clamp.
- Remove screw **1**.



Warning

Danger of accidents Damaged brake discs reduce the braking effect.

- Always lay the wheel down in such a way that the brake disc is not damaged.

- Hold the front wheel and remove the wheel spindle. Take the front wheel out of the fork.



Info

Do not actuate the hand brake lever when the front wheel is removed.

- Remove spacers **3**.

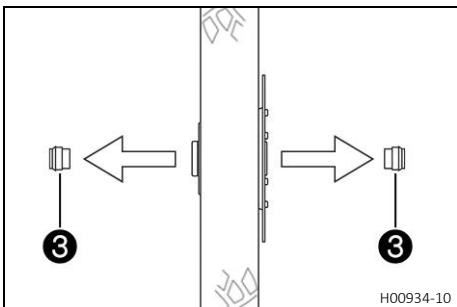

13.2 Installing the front wheel



Warning

Danger of accidents Oil or grease on the brake discs reduces the braking effect.

- Always keep the brake discs free of oil and grease.
- Clean the brake discs with brake cleaner when necessary.

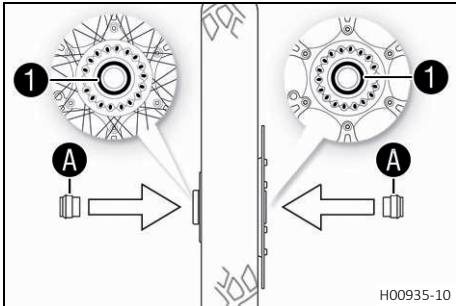

- Check the wheel bearing for damage and wear.
 - » If the wheel bearing is damaged or worn:
 - Change front wheel bearing.
- Clean and grease shaft seal rings 1 and contact surfaces A of the spacers.

Long-life grease (p. 122)

- Insert the spacers.
- Clean and grease the wheel spindle.

Long-life grease (p. 122)



- Position the front wheel and insert the wheel spindle.
 - ✓ The brake linings are correctly positioned.
- Mount and tighten screw 2.

Guideline

Screw, front wheel spindle	M20x1.5	35 Nm (25.8 lbf ft)
----------------------------	---------	---------------------

- Operate the hand brake lever several times until the brake linings are seated correctly against the brake disc.
- Remove the motorcycle from the lift stand. (p. 42)
- Operate the front brake and compress the fork a few times firmly.
 - ✓ The fork legs straighten.
- Tighten screws 3.

Guideline

Screw, fork stub	M8	15 Nm (11.1 lbf ft)
------------------	----	---------------------

13.3 Removing the rear wheel

Preparatory work

- Raise the motorcycle with a lift stand. (p. 42)

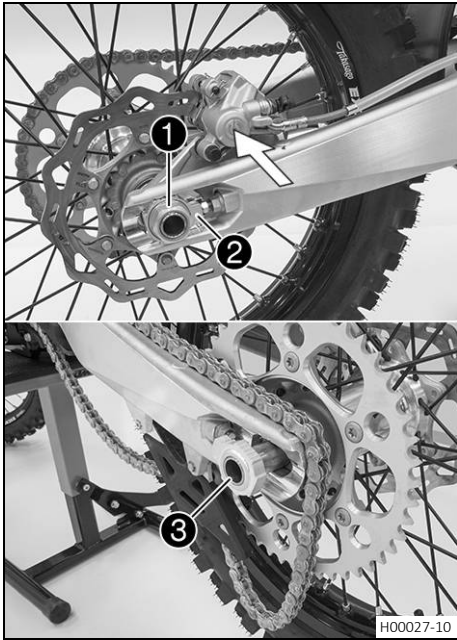

Main work

- Manually press the brake caliper toward the brake disc to push back the brake piston.



Info

Make sure that you do not press the brake caliper against the spokes when pushing back the brake piston.

- Remove nut ①.
- Take off chain adjuster ②. Pull out wheel spindle ③ far enough to allow the rear wheel to be pushed forward.
- Push the rear wheel forward as far as possible. Remove the chain from the rear sprocket.



Info

Cover the components to protect them against damage.



Warning

Danger of accidents Damaged brake discs reduce the braking effect.

- Always lay the wheel down in such a way that the brake disc is not damaged.

- Hold the rear wheel and remove the wheel spindle. Take the rear wheel out of the link fork.



Info

Do not operate the foot brake lever when the rear wheel is removed.

- Remove spacers ④.

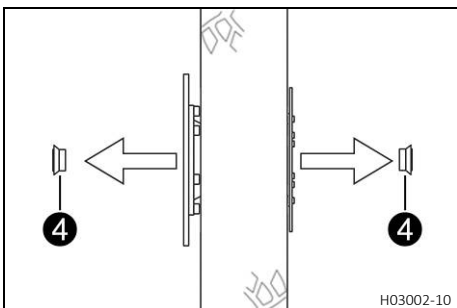

13.4 Installing the rear wheel



Warning

Danger of accidents Oil or grease on the brake discs reduces the braking effect.

- Always keep the brake discs free of oil and grease.
- Clean the brake discs with brake cleaner when necessary.

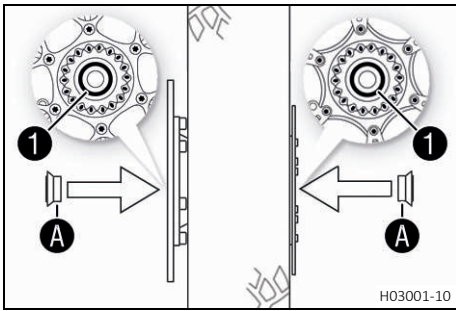

Main work

- Check the wheel bearing for damage and wear.
 - » If the wheel bearing is damaged or worn:
 - Change the rear wheel bearing. 🛠️
- Clean and grease shaft seal rings 1 and contact surfaces A of the spacers.

Long-life grease (📖 p. 122)

- Insert the spacers.
- Clean and grease the wheel spindle.

Long-life grease (📖 p. 122)

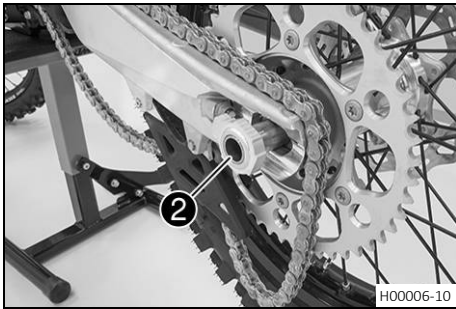

- Position rear wheel and insert wheel spindle 2.
 - ✓ The brake linings are correctly positioned.
- Mount the chain.

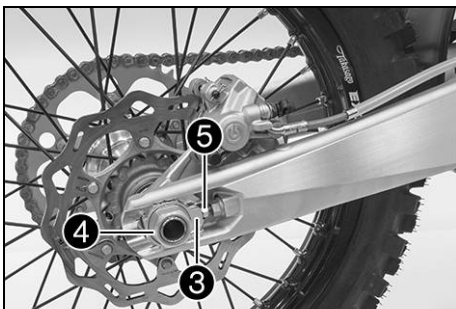

- Position chain adjuster 3. Mount nut 4, but do not tighten it yet.
- Make sure that chain adjusters 3 are fitted correctly on adjusting screws 5.
- Check the chain tension. (📖 p. 62)
- Tighten nut 4.

Guideline

Nut, rear wheel spindle	M25x1.5	80 Nm (59 lbf ft)
-------------------------	---------	-------------------



Info

The wide adjustment range of the chain adjusters (32 mm (1.26 in)) enables different secondary ratios with the same chain length.

Chain adjusters 3 can be turned by 180°.

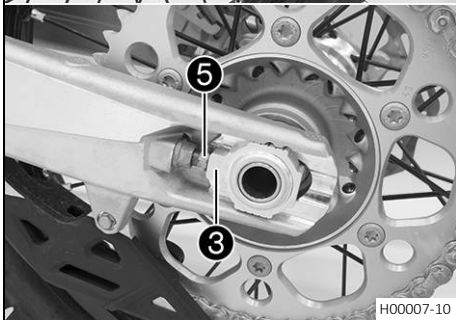

- Operate the foot brake lever repeatedly until the brake linings are in contact with the brake disc and there is a pressure point.

Finishing work

- Remove the motorcycle from the lift stand. (📖 p. 42)



13.5 Checking the tire condition



Info

Only mount tires approved and/or recommended by GASGAS Motorcycles.

Other tires could have a negative effect on handling characteristics.

The type, condition, and pressure of the tires all have a major impact on the handling characteristic of the motorcycle.

The tires mounted on the front and rear wheels must have a similar profile.

Worn tires have a negative effect on handling characteristics, especially on wet surfaces.

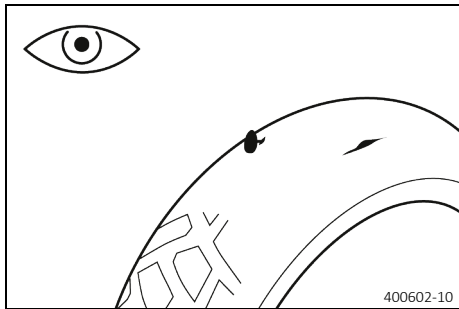

- Check the front and rear tires for cuts, embedded objects, and other damage.

- » If the tires have cuts, run-in objects, or other damage:
 - Change the tires. 🛠️

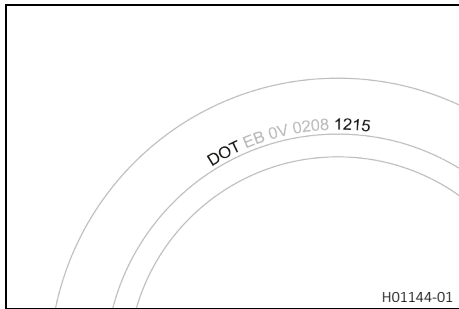

- Check the tire age.



Info

The tire date of manufacture is usually contained in the tire label and is indicated by the last four digits of the **DOT** number. The first two digits indicate the week of manufacture and the last two digits the year of manufacture.

GASGAS Motorcycles recommends that the tires be changed after five years at the latest, regardless of the actual wear.

- » If the tires are more than five years old:
 - Change the tires. 🛠️

13.6 Checking tire pressure



Info

Low tire pressure leads to abnormal wear and overheating of the tire.

Correct tire pressure ensures optimal riding comfort and maximum tire service life.

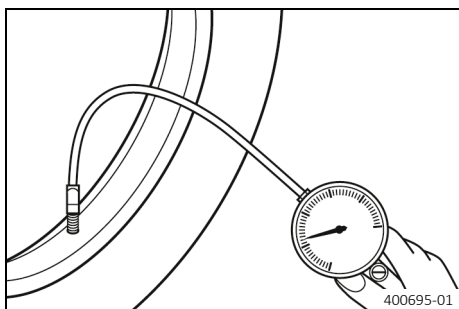

- Remove the protection cap.
- Check the tire pressure when the tires are cold.

Offroad tire pressure	
front	1.0 bar (15 psi)
rear	1.0 bar (15 psi)

- » If the tire pressure does not meet specifications:
 - Correct the tire pressure.

- Mount the protection cap.

13.7 Checking spoke tension



Warning

Danger of accidents Incorrectly tensioned spokes impair the handling characteristic and result in secondary damage.

The spokes break due to being overloaded if they are too tightly tensioned. If the tension in the spokes is too low, then lateral and radial run-out will form in the wheel. Other spokes will become looser as a result.

- Check spoke tension regularly, and in particular on a new vehicle. (Your authorized GASGAS Motorcycles workshop will be glad to help.)

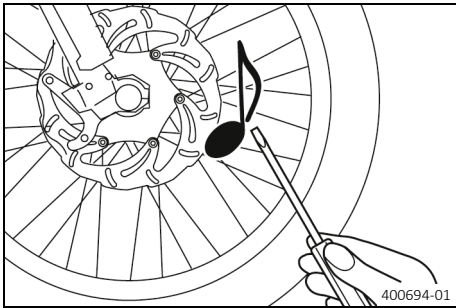

- Strike each spoke briefly using a screwdriver blade.

i Info

The frequency of the sound depends on the spoke length and spoke diameter. If you hear different tone frequencies from different spokes of equal length and diameter, this is an indication of different spoke tensions.

You should hear a high note.

- » If the spoke tension differs:
 - Correct the spoke tension. ↩

- Check the spoke torque.

Guideline

Spoke nipple, front wheel	M4.5	6 Nm (4.4 lbf ft)
Spoke nipple, rear wheel	M4.5	6 Nm (4.4 lbf ft)

Torque wrench kit (58429094000)

14.1 Cooling system

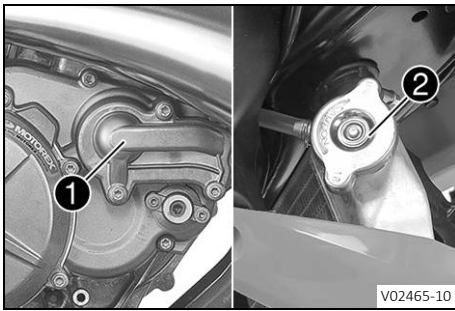

Water pump **1** in the engine ensures forced circulation of the coolant. The pressure resulting from the warming of the cooling system is regulated by a valve in radiator cap **2**. This ensures that operating the vehicle at the specified coolant temperature will not result in a risk of malfunctions.

14.2 Checking the antifreeze and coolant level



Warning

Danger of scalding During motorcycle operation, the coolant gets very hot and is under pressure.

- Do not open the radiator, the radiator hoses or other cooling system components if the engine or the cooling system are at operating temperature.
- Allow the cooling system and the engine to cool down before you open the radiator, the radiator hoses or other components of the cooling system.
- In the event of scalding, rinse the area affected immediately with lukewarm water.



Warning

Danger of poisoning Coolant is toxic and a health hazard.

- Keep coolant out of the reach of children.
- Do not allow coolant to come into contact with the skin, the eyes and clothing.
- Consult a doctor immediately if coolant is swallowed.
- Rinse the affected area immediately with plenty of water in the event of contact with the skin.
- Rinse eyes thoroughly with water and consult a doctor immediately if coolant gets into the eyes.
- Change clothing if coolant spills onto your clothing.

Condition

The engine is cold.

- Stand the motorcycle upright on a horizontal surface.
- Remove the radiator cap.
- Check the coolant antifreeze.

-25 ... -45 °C (-13 ... -49 °F)

- » If the antifreeze in the coolant does not match the specified value:
 - Correct the coolant antifreeze.

- Check the coolant level in the radiator.

Coolant level A above the radiator fins	10 mm (0.39 in)
--	-----------------

- » If the coolant level does not match the specified value:
 - Correct the coolant level.

Coolant (📖 p. 120)

- Mount the radiator cap.

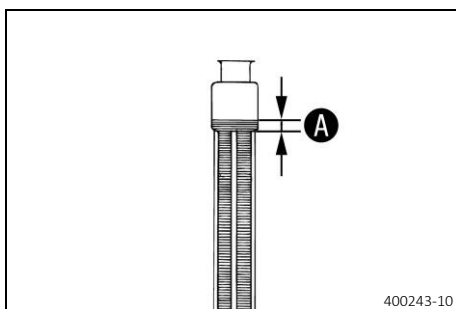

14.3 Checking the coolant level



Warning

Danger of scalding During motorcycle operation, the coolant gets very hot and is under pressure.

- Do not open the radiator, the radiator hoses or other cooling system components if the engine or the cooling system are at operating temperature.
- Allow the cooling system and the engine to cool down before you open the radiator, the radiator hoses or other components of the cooling system.
- In the event of scalding, rinse the area affected immediately with lukewarm water.



Warning

Danger of poisoning Coolant is toxic and a health hazard.

- Keep coolant out of the reach of children.
- Do not allow coolant to come into contact with the skin, the eyes and clothing.
- Consult a doctor immediately if coolant is swallowed.
- Rinse the affected area immediately with plenty of water in the event of contact with the skin.
- Rinse eyes thoroughly with water and consult a doctor immediately if coolant gets into the eyes.
- Change clothing if coolant spills onto your clothing.

Condition

The engine is cold.

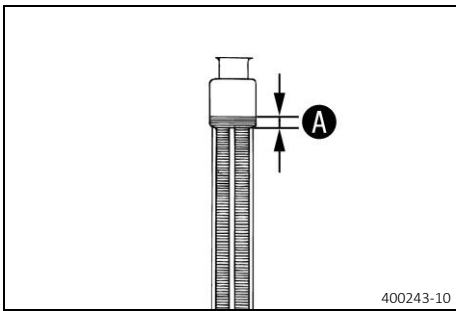

- Stand the motorcycle upright on a horizontal surface.
- Remove the radiator cap.
- Check the coolant level in the radiator.

Coolant level A above the radiator fins	10 mm (0.39 in)
--	-----------------

- » If the coolant level does not match the specified value:
 - Correct the coolant level.

Coolant (🔧 p. 120)

- Mount the radiator cap.

14.4 Draining the coolant



Warning

Danger of scalding During motorcycle operation, the coolant gets very hot and is under pressure.

- Do not open the radiator, the radiator hoses or other cooling system components if the engine or the cooling system are at operating temperature.
- Allow the cooling system and the engine to cool down before you open the radiator, the radiator hoses or other components of the cooling system.
- In the event of scalding, rinse the area affected immediately with lukewarm water.



Warning

Danger of poisoning Coolant is toxic and a health hazard.

- Keep coolant out of the reach of children.
- Do not allow coolant to come into contact with the skin, the eyes and clothing.
- Consult a doctor immediately if coolant is swallowed.
- Rinse the affected area immediately with plenty of water in the event of contact with the skin.
- Rinse eyes thoroughly with water and consult a doctor immediately if coolant gets into the eyes.
- Change clothing if coolant spills onto your clothing.

Condition

The engine is cold.

- Position the motorcycle upright.
- Place an appropriate container under the water pump cover.
- Remove screw ❶. Take off radiator cap ❷.
- Completely drain the coolant.
- Mount and tighten screw ❶ with a new seal ring.

Guideline

Screw, water pump cover	M6	10 Nm (7.4 lbf ft)
-------------------------	----	--------------------

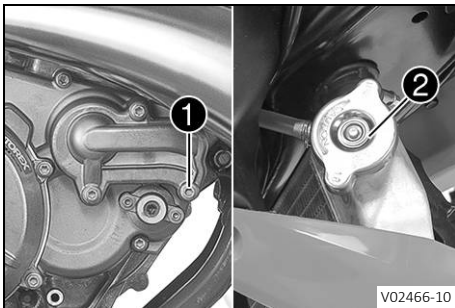

14.5 Refilling with coolant



Warning

Danger of poisoning Coolant is toxic and a health hazard.

- Keep coolant out of the reach of children.
- Do not allow coolant to come into contact with the skin, the eyes and clothing.
- Consult a doctor immediately if coolant is swallowed.
- Rinse the affected area immediately with plenty of water in the event of contact with the skin.
- Rinse eyes thoroughly with water and consult a doctor immediately if coolant gets into the eyes.
- Change clothing if coolant spills onto your clothing.

Main work

- Make sure that screw ❶ is tightened.
- Position the motorcycle upright.



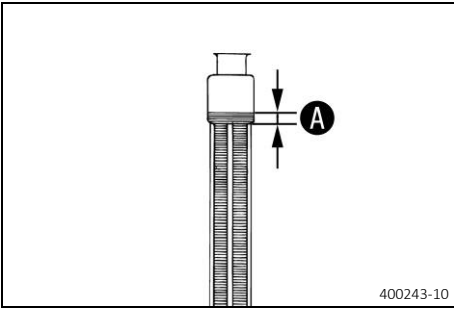

- Pour coolant in up to level **A** above the radiator fins.

Guideline

10 mm (0.39 in)
Coolant (📖 p. 120)

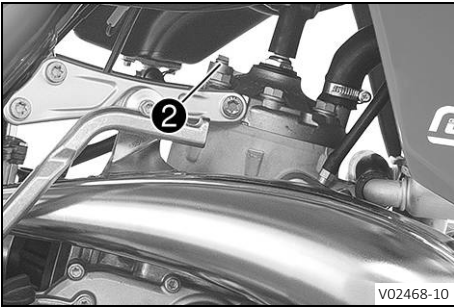

- Remove screw **2** and wait until coolant emerges without bubbles.
- Mount and tighten screw **2**.

Guideline

Bleeder screw, cylinder head	M6	10 Nm (7.4 lbf ft)
------------------------------	----	--------------------

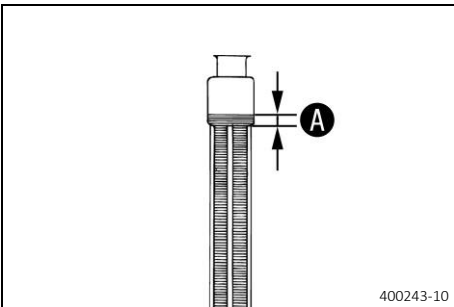

- Pour coolant in up to level **A** above the radiator fins.

Guideline

10 mm (0.39 in)
Coolant (📖 p. 120)



- Mount radiator cap **3**.



Danger

Danger of poisoning Exhaust gases are toxic and inhaling them may result in unconsciousness and death.

- Always make sure there is sufficient ventilation when running the engine.
- Use effective exhaust extraction when starting or running the engine in an enclosed space.

- Allow the engine to warm up and cool down again.

Finishing work

- Check the coolant level. (📖 p. 89)

14.6 Changing the coolant



Warning

Danger of scalding During motorcycle operation, the coolant gets very hot and is under pressure.

- Do not open the radiator, the radiator hoses or other cooling system components if the engine or the cooling system are at operating temperature.
- Allow the cooling system and the engine to cool down before you open the radiator, the radiator hoses or other components of the cooling system.
- In the event of scalding, rinse the area affected immediately with lukewarm water.



Warning

Danger of poisoning Coolant is toxic and a health hazard.

- Keep coolant out of the reach of children.
- Do not allow coolant to come into contact with the skin, the eyes and clothing.
- Consult a doctor immediately if coolant is swallowed.
- Rinse the affected area immediately with plenty of water in the event of contact with the skin.
- Rinse eyes thoroughly with water and consult a doctor immediately if coolant gets into the eyes.
- Change clothing if coolant spills onto your clothing.

Condition

The engine is cold.

- Position the motorcycle upright.
- Place an appropriate container under the water pump cover.
- Remove screw ❶. Take off radiator cap ❷.
- Completely drain the coolant.
- Mount and tighten screw ❶ with a new seal ring.

Guideline

Screw, water pump cover	M6	10 Nm (7.4 lbf ft)
-------------------------	----	--------------------

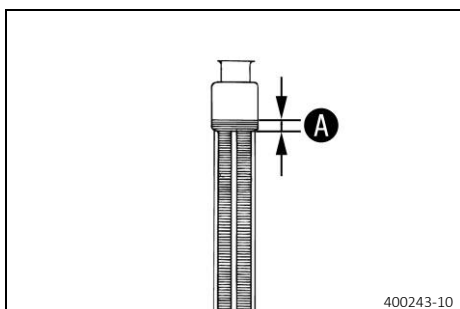
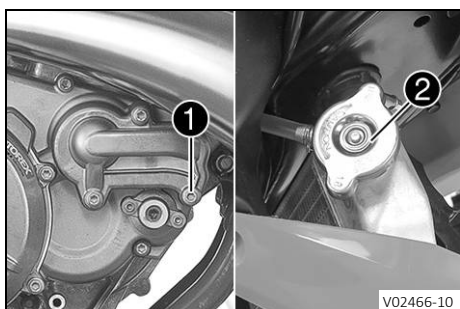

- Pour coolant in up to level A above the radiator fins.

Guideline

10 mm (0.39 in)

Coolant (📖 p. 120)

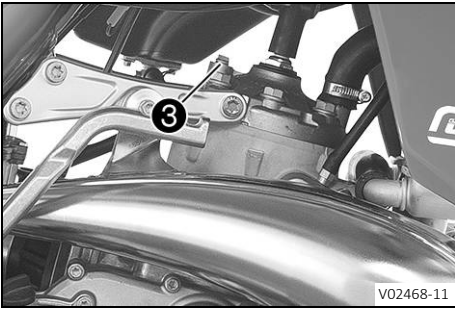

- Remove screw ③ and wait until coolant emerges without bubbles.
- Mount and tighten screw ③.

Guideline

Bleeder screw, cylinder head	M6	10 Nm (7.4 lbf ft)
------------------------------	----	--------------------

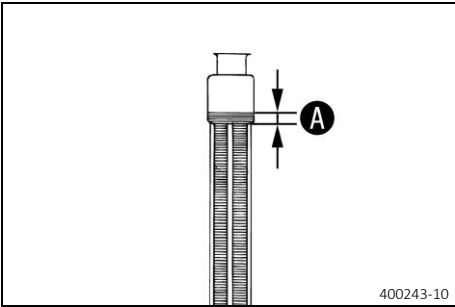

- Pour coolant in up to level A above the radiator fins.

Guideline

10 mm (0.39 in)

Coolant (📖 p. 120)

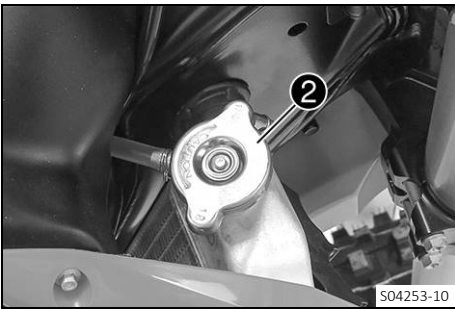

- Mount radiator cap ②.



Danger

Danger of poisoning Exhaust gases are toxic and inhaling them may result in unconsciousness and death.

- Always make sure there is sufficient ventilation when running the engine.
- Use effective exhaust extraction when starting or running the engine in an enclosed space.

- Allow the engine to warm up and cool down again.
- Check the cooling system for leaks.

Finishing work

- Check the coolant level. (📖 p. 89)



15.1 Checking the play in the throttle cable

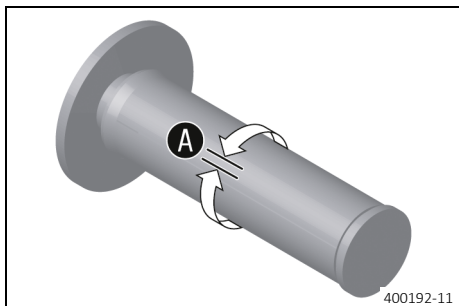

- Check the throttle grip for smooth operation.
- Move the handlebar to the straight-ahead position. Turn the throttle grip back and forth slightly and determine the play in throttle cable **A**.

Play in throttle cable	2 ... 3 mm (0.08 ... 0.12 in)
------------------------	-------------------------------

- » If the throttle cable play does not meet the specified value:
 - Adjust the play in the throttle cable. 🛠️ (p. 94)



Danger

Danger of poisoning Exhaust gases are toxic and inhaling them may result in unconsciousness and death.

- Always make sure there is sufficient ventilation when running the engine.
- Use effective exhaust extraction when starting or running the engine in an enclosed space.

- Start the engine and let it run at idle speed. Move the handlebar to and fro over the entire steering range.

The idle speed must not change.

- » If the idle speed changes:
 - Adjust the play in the throttle cable. 🛠️ (p. 94)

15.2 Adjusting the play in the throttle cable 🛠️



Info

If the correct routing of the throttle cable has already been secured, the fuel tank does not need to be removed.

Preparatory work

- Remove the seat. (p. 53)
- Turn the knurled screw on the fuel tap all the way clockwise.
- Remove the fuel tank. 🛠️ (p. 59)
- Check the throttle cable routing. (p. 66)

Main work

- Move the handlebar to the straight-ahead position.
- Push back sleeve **1**.
- Ensure that the throttle cable sleeve is pushed all the way into barrel adjuster **2**.
- Loosen nut **3**.

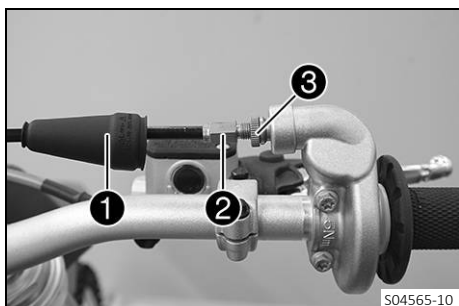

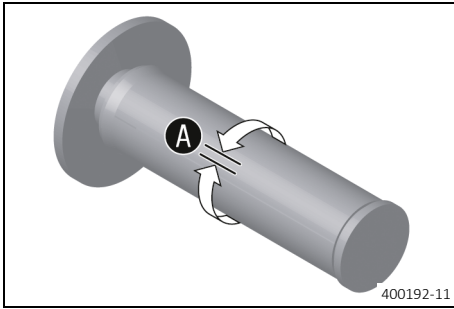

- Turn barrel adjuster **2** so that there is play **A** in the throttle cable at the throttle grip.

Guideline

Play in throttle cable	2 ... 3 mm (0.08 ... 0.12 in)
------------------------	-------------------------------

- Tighten nut **3**.
- Slide on sleeve **1**.

Finishing work

- Check the throttle grip for smooth operation.
- Install the fuel tank. (🔧 p. 60)
- Mount the seat. (🔧 p. 54)
- Check the play in the throttle cable. (🔧 p. 94)



15.3 Carburetor tuning

Effects of carburetor tuning

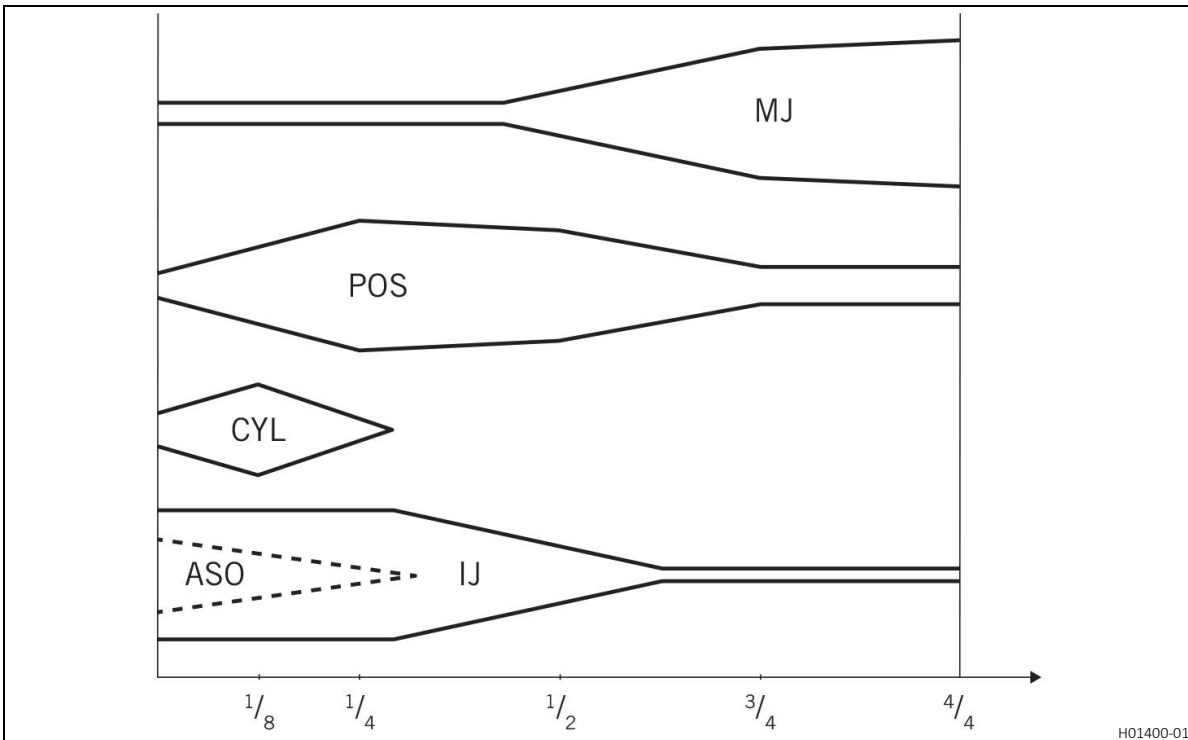

The different carburetor components must be tuned both to one another and for the use intended.

Main jet MJ

The main jet MJ has the greatest influence with the throttle slide open (full throttle).

If the insulator of a new spark plug is very light or white after a brief ride at full throttle, or if the engine knocks, a larger main jet needs to be used. If the insulator is dark brown or sooty, a smaller main jet needs to be used.

Needle position POS

The needle position has the greatest influence in the mid throttle slide range.

If the engine stutters when accelerating with a partially open throttle slide, the jet needle must be lowered. If the engine knocks when accelerating at the full power rpm range, the jet needle must be raised.

Cylindrical part of the needle CYL

The cylindrical part of the needle has the greatest influence when the throttle slide is almost closed.

Idling jet IJ

The idling jet has the greatest influence in the low to mid throttle slide range.

If the engine stutters at idle speed or when accelerating with a partially open throttle slide, a smaller idling jet must be used. If the engine knocks in this power range, then a larger idling jet must be used.

Idle air adjusting screw open ASO

The idle air adjusting screw has the greatest influence at idle speed.

Influence of throttle slide adjustment

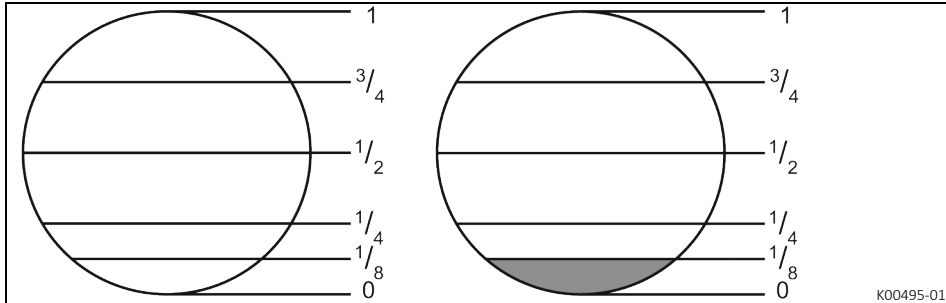

The idling jet has the greatest influence when the throttle slide is closed. The first cylindrical part of the needle and the clip position have only minimal influence.

When the throttle slide is 1/8 open, the first cylindrical part of the needle, the idling jet and the clip position have the greatest influence.

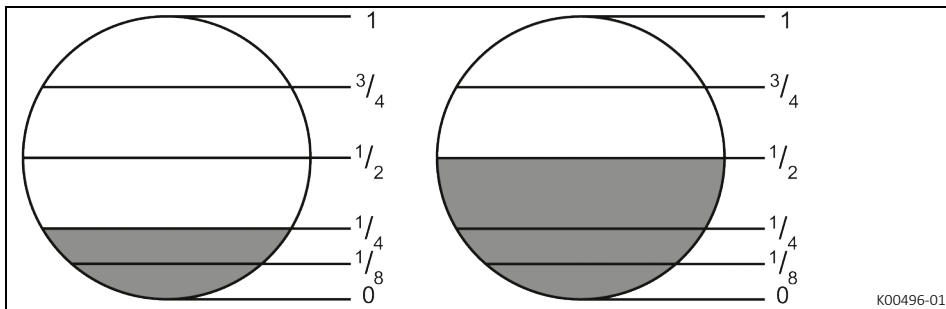

When the throttle slide is 1/4 open, the idling jet and the clip position have the greatest influence. The influence of the first cylindrical part of the needle is less.

When the throttle slide is 1/2 open, the position of the needle has the greatest influence. The influence of the main jet and the idling jet is only minimal.

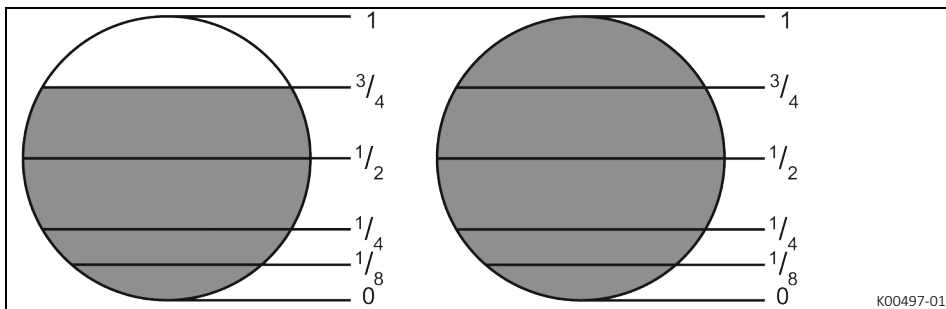

When the throttle slide is 3/4 open, the influence of the main jet is greatest. The clip position and the idling jet have only minimal influence.

When the throttle slide is fully open, the influence of the main jet is greatest. The clip position and the idling jet have only minimal influence.

Needle overview

The jet needles available are shown in the following table.

	1	2	3	4
A	6BFY42-71	6BFY43-71	6BFY44-71	2,71 mm
B	6BFY42-72	6BFY43-72	6BFY44-72	2.72 mm
C	6BFY42-73	6BFY43-73	6BFY44-73	2.73 mm
D	6BFY42-74	6BFY43-74	6BFY44-74	2.74 mm
E	6BFY42-75	6BFY43-75	6BFY44-75	2.75 mm
F	6BFY42-76	6BFY43-76	6BFY44-76	2.76 mm

402674-01

Column **2** corresponds to a needle in the standard position.
 Column **1** corresponds to a needle which is half a clip leaner.
 Column **3** corresponds to a needle which is half a clip richer.
 Column **4** specifies the diameter of the first cylindrical part of the needle. The smaller the diameter of the first cylindrical part of the needle, the richer the mixture preparation. The larger the diameter of the first cylindrical part of the needle, the leaner the mixture preparation. The first cylindrical part of the needle has the greatest influence in the lowest load range.

i Info

The top right jet needle **A3** corresponds to the richest setting of the carburetor, and the bottom left jet needle **F1** corresponds to the leanest. The optimal carburetor tuning is shown under the respective model.

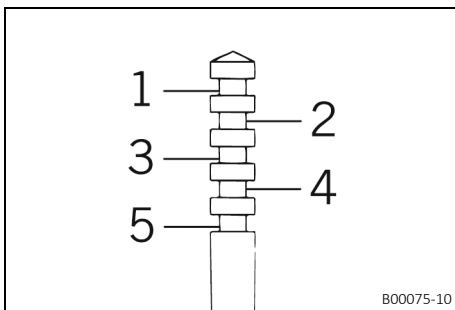

B00075-10

Clip position

1... 5	Clip position from above
--------	--------------------------

The five possible clip positions are shown here.
 The carburetor tuning depends on the defined ambient and operating conditions.

15.4 Carburetor – idle setting

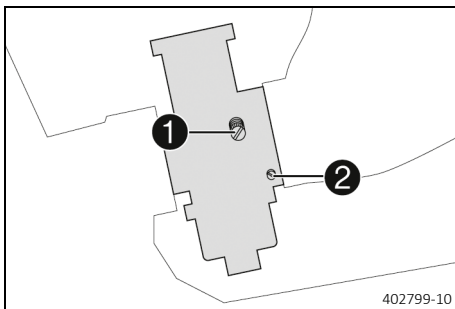

402799-10

The idle setting of the carburetor significantly influences the vehicle's starting behavior, the stability of the idle speed, and the vehicle's response when accelerating. This means that an engine with a correctly set idle speed will be easier to start than one with an incorrectly set idle speed.

i Info

The carburetor and its components are subject to increased wear caused by engine vibration. Wear can result in malfunctioning.

The factory setting for the carburetor is set for the following values.

Height above sea level	301 ... 750 m (988 ... 2,461 ft)
Ambient temperature	16 ... 24 °C (61 ... 75 °F)

The idle speed is adjusted with adjusting screw **1**.

The idle mixture is adjusted using the idle air adjusting screw **2**.

15.5 Carburetor – adjusting the idle speed

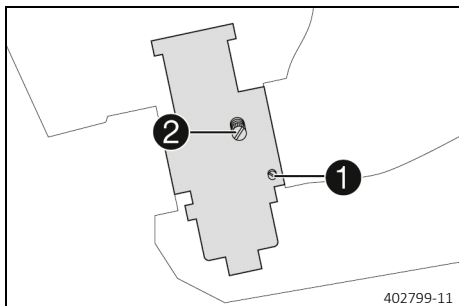

- Screw in idle air adjusting screw **1** all the way and turn it to the specified basic setting.
- Run the engine until warm.

Guideline

Warming-up phase	≥ 5 min
------------------	---------



Danger

Danger of poisoning Exhaust gases are toxic and inhaling them may result in unconsciousness and death.

- Always make sure there is sufficient ventilation when running the engine.
- Use effective exhaust extraction when starting or running the engine in an enclosed space.

- Adjust the idle speed with adjusting screw **2**.

Guideline

Choke function deactivated – The choke lever is pushed in to the stop. (📖 p. 16)	
Idle speed	1,400 ... 1,500 rpm

- Turn idle air adjusting screw **1** slowly in a clockwise direction until the idle speed begins to fall.
- Note the position and turn the idle air adjusting screw slowly counterclockwise until the idle speed again begins to fall.
- Adjust to the point between these two positions with the highest idle speed.



Info

If there is a big engine speed rise, reduce the idle speed to a normal level and repeat the above steps. If the procedure described here does not lead to satisfactory results, the cause may be a wrongly dimensioned idling jet. If you can turn the idle air adjusting screw to the end without any change of engine speed, mount a smaller idling jet. After changing the jet, start from the beginning with the adjusting steps. Following extreme air temperature or altitude changes, adjust the idle speed again.

15.6 Plug-in connector of ignition timing map adjustment

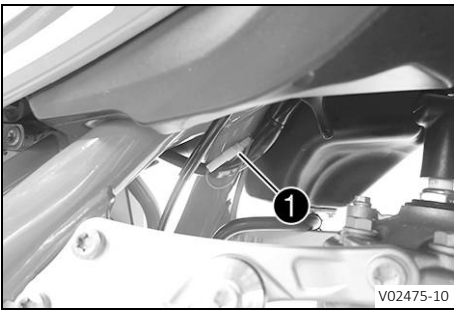

Plug-in connector ① of the ignition timing map adjustment is located on the frame under the fuel tank.

Possible states

- Soft – The plug-in connector of the ignition timing map adjustment is disconnected to achieve better rideability.
- Performance – The plug-in connector of the ignition timing map adjustment is joined to achieve higher performance.

15.7 Changing the ignition timing map

Switching the ignition timing map from Performance to Soft

- Disconnect plug-in connector ① of the ignition timing map adjustment. (Figure V02475-10 p. 99)
- ✓ Soft – better rideability

Switching the ignition timing map from Soft to Performance

- Join plug-in connector ① of the ignition timing map adjustment. (Figure V02475-10 p. 99)
- ✓ Performance – better performance

15.8 Checking the basic position of the shift lever

i Info

When driving, the shift lever must not touch the rider's boot when in the basic position. When the shift lever keeps touching the boot, the transmission will be subject to an excessive load.

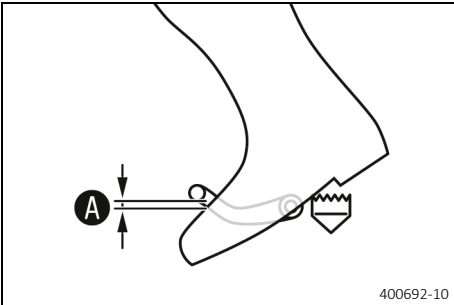

- Sit on the vehicle in the riding position and determine distance A between the upper edge of your boot and the shift lever.

Distance between shift lever and upper edge of boot	10 ... 20 mm (0.39 ... 0.79 in)
---	---------------------------------

- » If the distance does not meet specifications:
 - Adjust the basic position of the shift lever. p. 99

15.9 Adjusting the basic position of the shift lever

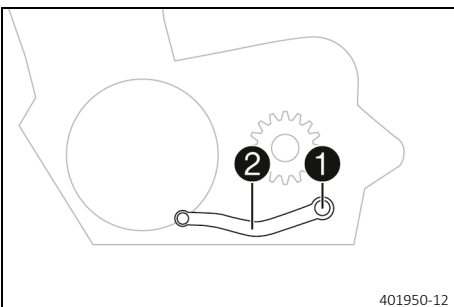

- Remove screw ① with the washers and take off shift lever ②.

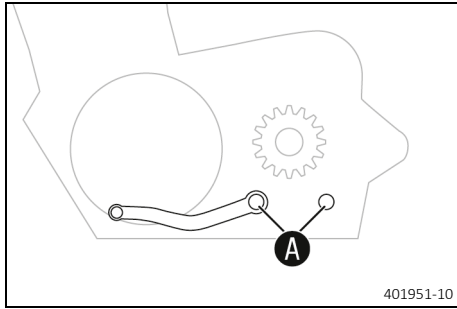

- Clean gear teeth **A** of the shift lever and shift shaft.
- Mount the shift lever on the shift shaft in the required position and engage gearing.



Info

The range of adjustment is limited.
The shift lever must not come into contact with any other vehicle components during the shift procedure.

- Mount and tighten screw **1** with washers.

Guideline

Screw, shift lever	M6	14 Nm (10.3 lbf ft) Loctite®243™
--------------------	----	--

15.10 Engine characteristic – adjusting the auxiliary spring ↗



Warning

Danger of burns Some vehicle components become very hot when the vehicle is operated.

- Do not touch any parts such as the exhaust system, radiator, engine, shock absorber, or brake system before the vehicle parts have cooled down.
- Let the vehicle parts cool down before you perform any work on the vehicle.

Preparatory work

- Tilt the motorcycle to the left and secure against falling in this position.

Guideline

Angle of title approx.	45°
------------------------	-----

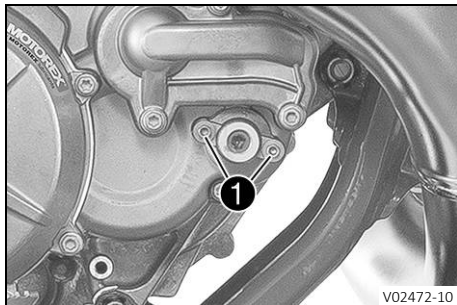

Main work

- Remove screws **1**.

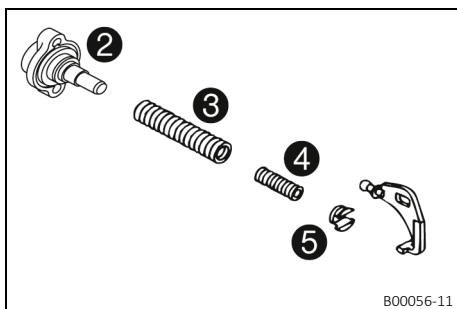

- Remove cap **2**, adjusting spring **3**, auxiliary spring **4**, and spring insert **5** from the clutch cover.
- Pull both springs off of the spring insert.

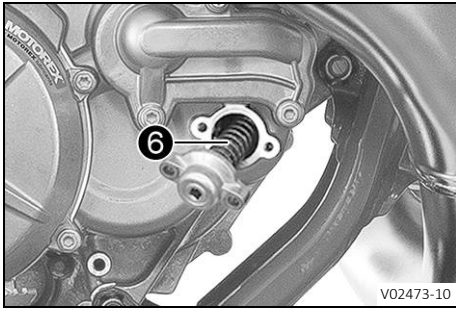

- Mount the required auxiliary spring 4 and adjusting spring 3 and position them together in the clutch cover.

Auxiliary spring with yellow marking (54637072300)
Auxiliary spring with green marking (54837072100)
Auxiliary spring with red marking (54837072000)

- ✓ The recess in spring insert 5 engages in the angle lever.

i Info
Screw 6 must not be turned as this would worsen the engine characteristic.

- Check the O-ring in the cap.
- Position the cap.
- Mount and tighten the screws.

Guideline

Screw, exhaust control cover	M5	4 Nm (3 lbf ft)
------------------------------	----	-----------------



16.1 Emptying the carburetor float chamber



Danger

Fire hazard Fuel is highly flammable.

The fuel in the fuel tank expands when warm and can escape if overfilled.

- Do not fuel the vehicle in the vicinity of open flames or lit cigarettes.
- Switch off the engine for refueling.
- Make sure that no fuel is spilled; particularly not on hot parts of the vehicle.
- If any fuel is spilled, wipe it off immediately.
- Observe the specifications for refueling.



Warning

Danger of poisoning Fuel is poisonous and a health hazard.

- Avoid skin, eye and clothing contact with fuel.
- Immediately consult a doctor if you swallow fuel.
- Do not inhale fuel vapors.
- In case of skin contact, rinse the affected area with plenty of water.
- Rinse the eyes thoroughly with water, and consult a doctor in case of fuel contact with the eyes.
- Change your clothing in case of fuel spills on them.
- Keep fuels correctly in a suitable canister, and out of the reach of children.



Note

Environmental hazard Improper handling of fuel is a danger to the environment.

- Do not allow fuel to enter the groundwater, the soil, or the sewage system.



Info

Carry out work with a cold engine.

Water in the float chamber results in malfunctioning.

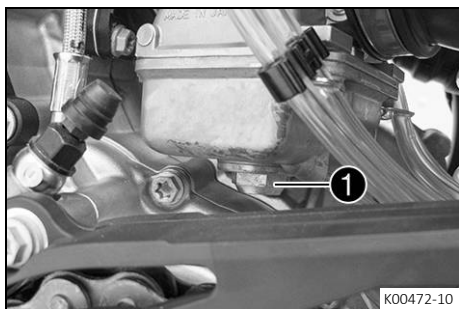

Preparatory work

- Turn the knurled screw on the fuel tap all the way clockwise.
- ✓ Fuel no longer flows from the fuel tank to the carburetor.

Main work

- Place a cloth under the carburetor to capture the draining fuel.
- Remove screw plug **1**.
- Fully drain the fuel.
- Mount and tighten the screw plug.

16.2 Checking the gear oil level

i Info
The gear oil level must be checked when the engine is cold.

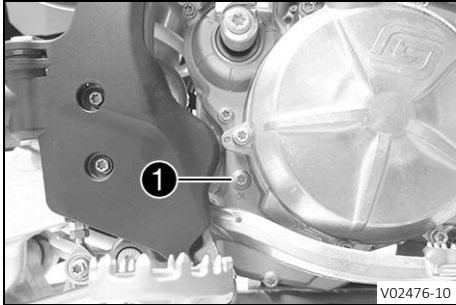

Preparatory work

- Stand the motorcycle upright on a horizontal surface.

Main work

- Detach the foot brake lever spring.
- Remove gear oil level monitoring screw **1**.
- Check the gear oil level.

A small quantity of gear oil must run out of the drilled hole.

- » If no gear oil runs out:
 - Add the gear oil. 🛠️ (p. 104)

- Mount and tighten the gear oil level monitoring screw.

Guideline

Screw, gear oil level monitoring	M6	8 Nm (5.9 lbf ft)
----------------------------------	----	-------------------

- Attach the foot brake lever spring.



16.3 Changing the gear oil 🛠️



Warning

Danger of scalding Engine and gear oil get very hot when the motorcycle is ridden.

- Wear suitable protective clothing and safety gloves.
- In the event of scalding, rinse the area affected immediately with lukewarm water.



Note

Environmental hazard Hazardous substances cause environmental damage.

- Dispose of oils, grease, filters, fuel, cleaning agents, brake fluid, etc., correctly and in compliance with the applicable regulations.

i Info
Drain the gear oil while the engine is at operating temperature.

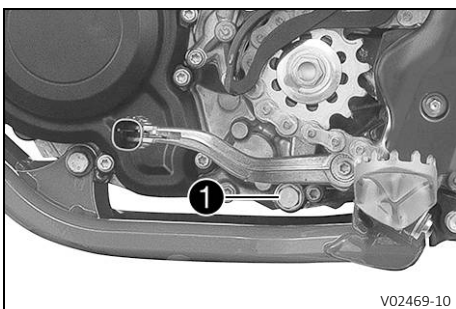

Preparatory work

- Park the motorcycle on a level surface.
- Position an appropriate container under the engine.

Main work

- Remove gear oil drain plug **1** with magnet.
- Let the gear oil drain fully.
- Thoroughly clean the gear oil drain plug with magnet.
- Clean the sealing surface on the engine.
- Mount and tighten gear oil drain plug **1** with the magnet and a new seal ring.

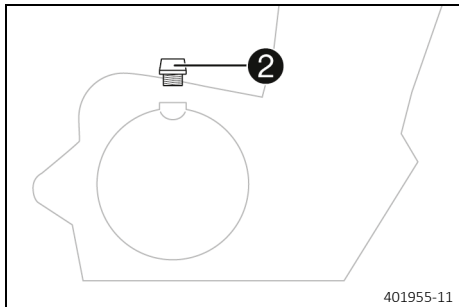

Guideline

Gear oil drain plug with magnet	M12x1.5	20 Nm (14.8 lbf ft)
---------------------------------	---------	---------------------

- Remove filler plug ② with the O-ring, and fill up with gear oil.

Gear oil	0.80 l (0.85 qt.)	Engine oil (15W/50) (📖 p. 120)
----------	-------------------	--------------------------------

- Mount and tighten the filler plug together with the O-ring.



Danger

Danger of poisoning Exhaust gases are toxic and inhaling them may result in unconsciousness and death.

- Always make sure there is sufficient ventilation when running the engine.
- Use effective exhaust extraction when starting or running the engine in an enclosed space.

- Start the engine and check it for leaks.

Finishing work

- Check the gear oil level. (📖 p. 103)

16.4 Adding the gear oil 🛠️

i Info

Too little gear oil or poor-quality gear oil results in premature wear to the transmission. Gear oil must only be topped up when the engine is cold.

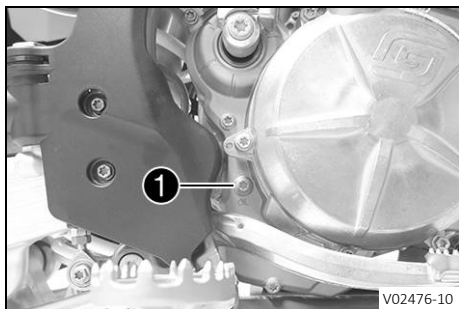

Preparatory work

- Park the motorcycle on a level surface.

Main work

- Remove gear oil level monitoring screw ①.

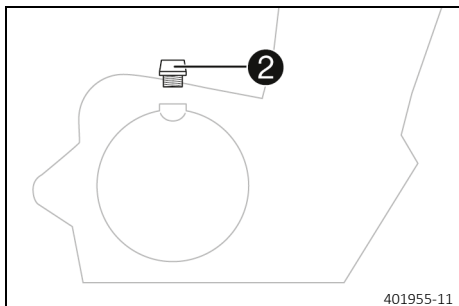

- Remove filler plug ② with the O-ring.
- Add gear oil until it emerges from the drill hole of the gear oil level monitoring screw.

Engine oil (15W/50) (📖 p. 120)

- Mount and tighten the gear oil level monitoring screw.

Guideline

Screw, gear oil level monitoring	M6	8 Nm (5.9 lbf ft)
----------------------------------	----	-------------------

- Mount and tighten filler plug ② together with the O-ring.

Finishing work**Danger**

Danger of poisoning Exhaust gases are toxic and inhaling them may result in unconsciousness and death.

- Always make sure there is sufficient ventilation when running the engine.
- Use effective exhaust extraction when starting or running the engine in an enclosed space.

- Start the engine and check it for leaks.



17.1 Cleaning the motorcycle

Note

Material damage Components become damaged or destroyed if a pressure cleaner is used incorrectly.

The high pressure forces water into the electrical components, connectors, throttle cables, and bearings, etc. Pressure which is too high causes malfunctions and destroys components.

- Do not direct the water jet directly on to electrical components, connectors, throttle cables or bearings.
- Maintain a minimum distance between the nozzle of the pressure cleaner and the component.
Minimum clearance 60 cm (23.6 in)



Note

Environmental hazard Hazardous substances cause environmental damage.

- Dispose of oils, grease, filters, fuel, cleaning agents, brake fluid, etc., correctly and in compliance with the applicable regulations.



Info

To maintain the value and appearance of the motorcycle over a long period, clean it regularly. Avoid direct sunshine when cleaning the motorcycle.

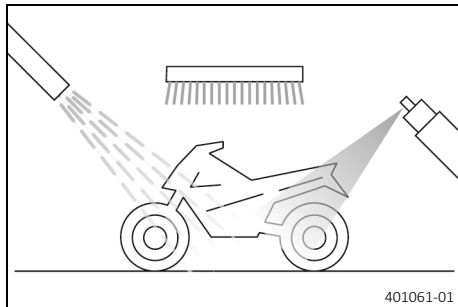

- Close off exhaust system to keep water from entering.
- Remove the coarse dirt particles with a gentle water jet.
- Spray the heavily soiled parts with a normal commercial motorcycle cleaner and clean using a brush.

Motorcycle cleaner (📖 p. 122)



Info

Use warm water containing normal motorcycle cleaner and a soft sponge. Never apply motorcycle cleaner to a dry vehicle; always rinse the vehicle with water first.

- After rinsing the motorcycle with a gentle spray of water, allow it to dry thoroughly.
- Empty the carburetor float chamber. 🛠️ (📖 p. 102)
- Remove the closure of the exhaust system.



Warning

Danger of accidents Moisture and dirt impair the brake system.

- Brake carefully several times to dry out and remove dirt from the brake linings and the brake discs.

- After cleaning, ride the vehicle a short distance until the engine warms up.



Info

The heat produced causes water at inaccessible locations in the engine and on the brake system to evaporate.

- After the motorcycle has cooled down, lubricate all moving parts and pivot points.
- Clean the chain. (📖 p. 62)

- Treat bare metal (except for brake discs and the exhaust system) with a corrosion inhibitor.

Preserving materials for paints, metal and rubber (📖 p. 122)

- Treat all plastic parts and powder-coated parts with a mild cleaning and care product.

Special cleaner for glossy and matte paint finishes, metal and plastic surfaces (📖 p. 122)



18.1 Storage

**Warning****Danger of poisoning** Fuel is poisonous and a health hazard.

- Avoid skin, eye and clothing contact with fuel.
- Immediately consult a doctor if you swallow fuel.
- Do not inhale fuel vapors.
- In case of skin contact, rinse the affected area with plenty of water.
- Rinse the eyes thoroughly with water, and consult a doctor in case of fuel contact with the eyes.
- Change your clothing in case of fuel spills on them.
- Keep fuels correctly in a suitable canister, and out of the reach of children.

**Info**

If you plan to garage the motorcycle for a longer period, perform the following steps or have them performed. Before storing the motorcycle, check all parts for function and wear. If service, repairs, or replacements are necessary, you should do this during the storage period (less workshop overload). In this way, you can avoid long workshop waiting times at the start of the new season.

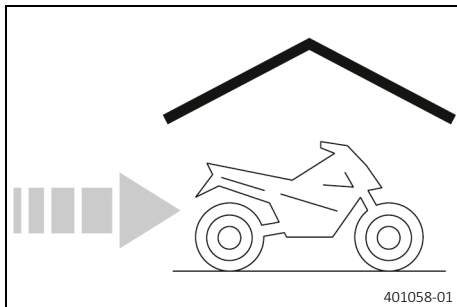

- When refueling for the last time before taking the motorcycle out of service, add fuel additive.

Fuel additive (📖 p. 122)

- Refuel. (📖 p. 28)
- Clean the motorcycle. (📖 p. 106)
- Change the gear oil. 🛠️ (📖 p. 103)
- Check the antifreeze and coolant level. (📖 p. 88)
- Empty the carburetor float chamber. 🛠️ (📖 p. 102)
- Check tire pressure. (📖 p. 86)
- Store the vehicle in a dry location that is not subject to large fluctuations in temperature.

**Info**

GASGAS Motorcycles recommends jacking up the motorcycle.

- Raise the motorcycle with a lift stand. (📖 p. 42)
- Cover the vehicle with a tarp or a similar cover that is permeable to air.

**Info**

Do not use non-porous materials since they prevent humidity from escaping, thus causing corrosion. Avoid running the engine for a short time only. Because the engine will not warm up sufficiently, the water vapor produced during combustion will condense, causing engine parts and the exhaust system to rust.

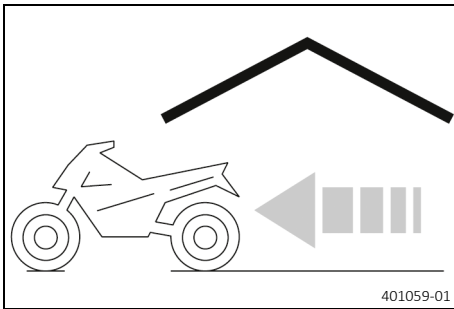
18.2 Preparing for use after storage

- Remove the motorcycle from the lift stand. (📖 p. 42)
- Perform checks and maintenance measures when preparing for use. (📖 p. 25)
- Take a test ride.



Faults	Possible cause	Action
Engine turns but does not start	Operating error	– Carry out start procedure. (📖 p. 25)
	The motorcycle has been in disuse for an extended period and old fuel is in the float chamber	– Empty the carburetor float chamber. 🛠️ (📖 p. 102)
	Fuel supply interrupted	– Check the fuel tank breather. – Clean the fuel tap. – Check/adjust the carburetor components.
	Spark plug sooty or wet	– Clean and dry the spark plug and spark plug connector, or change if necessary.
	Plug gap of spark plug too wide	– Adjust plug gap. Guideline Spark plug electrode gap 0.60 mm (0.0236 in)
	Fault in ignition system	– Check the ignition system. 🛠️
	Short-circuit cable in wiring harness frayed, stop button faulty	– Check the stop button. 🛠️
	The connector or ignition coil is loose or oxidized	– Clean the connector and treat it with contact spray.
	Water in carburetor or jets blocked	– Check/set the carburetor components.
Engine has no idle speed	Idling jet blocked	– Check/set the carburetor components.
	Adjusting screws on carburetor distorted	– Carburetor – adjust the idle speed. 🛠️ (📖 p. 98)
	Spark plug defective	– Change the spark plug.
	Ignition system defective	– Check the ignition coil. 🛠️ – Check the spark plug connector. 🛠️
Engine does not speed up	Carburetor running over because float needle dirty or worn	– Check/set the carburetor components.
	Loose carburetor jets	– Check/set the carburetor components.
	Fault in ignition system	– Check the ignition system. 🛠️
Engine has too little power	Fuel supply interrupted	– Check the fuel tank breather. – Clean the fuel tap. – Check/adjust the carburetor components.
	Air filter very dirty	– Clean the air filter and air filter box. 🛠️ (📖 p. 56)
	Exhaust system leaky, deformed or too little glass fiber yarn filling in main silencer	– Check exhaust system for damage. – Change the glass fiber yarn filling in the main silencer. 🛠️ (📖 p. 58)
	Fault in ignition system	– Check the ignition system. 🛠️
	Diaphragm or reed valve housing damaged	– Check the diaphragm and reed valve housing.
Engine stalls or is popping into the carburetor	Lack of fuel	– Turn the knurled screw on the fuel tap all the way counterclockwise. – Refuel. (📖 p. 28)
	Engine takes in bad air	– Check the intake flange and carburetor for tightness.
	The connector or ignition coil is loose or oxidized	– Clean the connector and treat it with contact spray.

Faults	Possible cause	Action
Engine overheats	Too little coolant in cooling system	<ul style="list-style-type: none"> – Check the cooling system for leakage. – Check the coolant level. (📖 p. 89)
	Too little air stream	<ul style="list-style-type: none"> – Switch off engine when stationary.
	Radiator fins very dirty	<ul style="list-style-type: none"> – Clean the radiator fins.
	Foam formation in cooling system	<ul style="list-style-type: none"> – Drain the coolant. 🛠️ (📖 p. 89) – Refill with coolant. 🛠️ (📖 p. 90)
	Damaged cylinder head or cylinder head gasket	<ul style="list-style-type: none"> – Check the cylinder head and cylinder head gasket.
	Bent radiator hose	<ul style="list-style-type: none"> – Change the radiator hose. 🛠️
White smoke emission (steam in exhaust gas)	Damaged cylinder head or cylinder head gasket	<ul style="list-style-type: none"> – Check the cylinder head and cylinder head gasket.
Gear oil exits at the vent hose	Too much gear oil added	<ul style="list-style-type: none"> – Check the gear oil level. (📖 p. 103)
Water in the gear oil	Damaged radial shaft seal ring or water pump	<ul style="list-style-type: none"> – Check the radial shaft seal ring and the water pump.

20.1 Engine

Design	1-cylinder 2-stroke engine, water-cooled, with reed intake and exhaust control
Displacement	249 cm ³ (15.19 cu in)
Stroke	72 mm (2.83 in)
Hole	66.4 mm (2.614 in)
Crankshaft bearing	1 grooved ball bearing/1 roller bearing
Conrod bearing	Needle bearing
Piston pin bearing	Needle bearing
Piston	Cast aluminum
Piston rings	2 half keystone rings
X distance (upper edge of piston to upper edge of cylinder)	0 ... 0.10 mm (0 ... 0.0039 in)
Z distance (height of control flap)	49.0 mm (1.929 in)
Primary transmission	26:73
Clutch	Multidisc clutch in oil bath/hydraulically activated
Transmission	5-gear transmission, claw shifted
Transmission ratio	
first-gear	14:28
second-gear	16:26
third-gear	18:24
fourth-gear	21:24
fifth-gear	22:21
Ignition system	Contactless controlled fully electronic ignition with digital ignition adjustment
Spark plug	NGK BR 8 ECM
Spark plug electrode gap	0.60 mm (0.0236 in)
Starting aid	Kick starter system

20.2 Engine tightening torques

Screw, inner membrane sheets	EJOTDELTA PT® 35x25	1 Nm (0.7 lbf ft)	
Screw, membrane support plate	EJOTDELTA PT® 30x12	1 Nm (0.7 lbf ft)	
Screw, outer membrane sheets	EJOTDELTA PT® 30x6	1 Nm (0.7 lbf ft)	
Screw, angle lever, exhaust control	M5	6 Nm (4.4 lbf ft)	Loctite®243™
Screw, bearing retainer	M5	6 Nm (4.4 lbf ft)	Loctite®243™
Screw, clutch spring retainer	M5	6 Nm (4.4 lbf ft)	
Screw, crankshaft speed sensor	M5	6 Nm (4.4 lbf ft)	Loctite®243™
Screw, exhaust control bearing support	M5	6 Nm (4.4 lbf ft)	Loctite®243™
Screw, exhaust control cover	M5	4 Nm (3 lbf ft)	
Screw, locking lever	M5	6 Nm (4.4 lbf ft)	Loctite®243™
Screw, retaining bracket of exhaust control	M5	6 Nm (4.4 lbf ft)	Loctite®2701™

Screw, stator	M5	6 Nm (4.4 lbf ft)	Loctite®243™
Bleeder screw, cylinder head	M6	10 Nm (7.4 lbf ft)	
Nut, adjusting screw, power valve	M6	8 Nm (5.9 lbf ft)	
Nut, water pump impeller	M6	5 Nm (3.7 lbf ft)	Loctite®243™
Screw, alternator cover	M6	8 Nm (5.9 lbf ft)	
Screw, clutch cover	M6	10 Nm (7.4 lbf ft)	
Screw, clutch slave cylinder	M6	10 Nm (7.4 lbf ft)	
Screw, control flap, exhaust control	M6	10 Nm (7.4 lbf ft)	Loctite®243™
Screw, engine case	M6	10 Nm (7.4 lbf ft)	
Screw, exhaust control thrust bearing	M6	8 Nm (5.9 lbf ft)	Loctite®243™
Screw, exhaust flange	M6	8 Nm (5.9 lbf ft)	
Screw, gear oil level monitoring	M6	8 Nm (5.9 lbf ft)	
Screw, intake flange/reed valve housing	M6	6 Nm (4.4 lbf ft)	
Screw, kick starter intermediate gear steel pin	M6	10 Nm (7.4 lbf ft)	Loctite®243™
Screw, kick starter stop plate	M6	10 Nm (7.4 lbf ft)	Loctite®243™
Screw, outer clutch cover	M6	8 Nm (5.9 lbf ft)	
Screw, shift drum locating	M6	10 Nm (7.4 lbf ft)	Loctite®243™
Screw, shift lever	M6	14 Nm (10.3 lbf ft)	Loctite®243™
Screw, water pump cover	M6	10 Nm (7.4 lbf ft)	
Vacuum connection, housing breather	M6	2 Nm (1.5 lbf ft)	Loctite®243™
Screw, balancer shaft	M8	30 Nm (22.1 lbf ft)	Loctite®243™
Screw, cylinder head	M8	27 Nm (19.9 lbf ft)	
Screw, kick starter lever	M8	25 Nm (18.4 lbf ft)	Loctite®2701™
Nut, cylinder base	M10	35 Nm (25.8 lbf ft)	
Screw, cylinder base	M10	12 Nm (8.9 lbf ft)	
Screw, drive chain engine sprocket	M10	60 Nm (44.3 lbf ft)	Loctite®2701™
Nut, rotor	M12x1	60 Nm (44.3 lbf ft)	
Gear oil drain plug with magnet	M12x1.5	20 Nm (14.8 lbf ft)	
Spark plug	M14x1.25	25 Nm (18.4 lbf ft)	
Nut, inner clutch hub	M18x1.5	100 Nm (73.8 lbf ft)	Loctite®243™
Nut, primary gear wheel	M18LHx1.5	150 Nm (110.6 lbf ft)	Loctite®243™

20.3 Carburetor

Carburetor type	MIKUNI TMX 38
Carburetor identification number	TMX 38 89
Needle position	3rd position from top
Jet needle	6BFY42-71 (6BFY43-71)
Main jet	450 (430, 440, 460, 470)
Idling jet	35 (30 / 32.5 / 37.5 / 40)
Choke nozzle	80
Needle jet	S-1
Idle air adjusting screw	
open	1.5 turns

20.3.1 Carburetor tuning

MIKUNI TMX 38

ASL	TEMP	-20 ... -7 °C (-4 ... 19 °F)	-6 ... 5 °C (21 ... 41 °F)	6 ... 15 °C (43 ... 59 °F)	16 ... 24 °C (61 ... 75 °F)	25 ... 36 °C (77 ... 97 °F)	37 ... 49 °C (99 ... 120 °F)
2,301 ... 3,000 m (7,549 ... 9,843 ft)	ASO IJ NDL POS MJ	1.5 35 42-71 3 450	1.5 32.5 42-71 3 440	2 32.5 42-71 3 430	1.5 32.5 43-71 2 430	1.5 30 43-71 2 420	
1,501 ... 2,300 m (4,925 ... 7,546 ft)	ASO IJ NDL POS MJ	1.5 32.5 43-71 3 450	1.5 35 42-71 3 450	1.5 32.5 42-71 3 440	2 32.5 42-71 3 430	1.5 32.5 43-71 2 430	1.5 30 43-71 2 420
751 ... 1,500 m (2,464 ... 4,921 ft)	ASO IJ NDL POS MJ	1.5 35 43-71 3 460	1.5 32.5 43-71 3 450	1.5 35 42-71 3 450	1.5 32.5 42-71 3 440	2 32.5 42-71 3 430	1.5 32.5 43-71 2 430
301 ... 750 m (988 ... 2,461 ft)	ASO IJ NDL POS MJ	1.5 37.5 43-71 3 470	1.5 35 43-71 3 460	1.5 32.5 43-71 3 450	1,5 35 42-71 3 450	1.5 32.5 42-71 3 440	2 30 42-71 3 430
0 ... 300 m (0 ... 984 ft)	ASO IJ NDL POS MJ	1.5 37.5 43-71 3 470	1.5 35 43-71 3 460	1.5 32.5 43-71 3 450	1.5 35 42-71 3 450	1.5 32.5 42-71 3 440	2 32.5 42-71 3 430

ASL	Sea level
TEMP	Temperature
ASO	Idle air adjusting screw open
IJ	Idling jet
NDL	Needle
POS	Needle position from top
MJ	Main jet



Info

Do not use on sandy terrain.

20.3.2 Basic carburetor setting for sandy surfaces

Idle air adjusting screw	
open	1.5 turns
Idling jet	37.5
Jet needle	6BFY43-71
Needle position	3rd position from top
Main jet	470



Info

If the engine is not running smoothly, use a smaller main jet.

20.4 Capacities

20.4.1 Gear oil

Gear oil	0.80 l (0.85 qt.)	Engine oil (15W/50) (📖 p. 120)
----------	-------------------	--------------------------------

20.4.2 Coolant

Coolant	1.2 l (1.3 qt.)	Coolant (📖 p. 120)
---------	-----------------	--------------------

20.4.3 Fuel

Total fuel tank capacity, approx.	7.5 l (1.98 US gal)	Super unleaded (95 octane) mixed with 2-stroke engine oil (1:60) (📖 p. 121)
-----------------------------------	---------------------	---

20.5 Chassis

Frame	Central tube frame made of chrome molybdenum steel tubing
Fork	WP XACT AER
Shock absorber	WP XACT 5750
Suspension travel	
front	310 mm (12.2 in)
rear	300 mm (11.81 in)
Fork offset	22 mm (0.87 in)
Brake system	Disc brakes, floating brake calipers
Brake discs - diameter	
front	260 mm (10.24 in)
rear	220 mm (8.66 in)
Brake discs - wear limit	
front	2.5 mm (0.098 in)
rear	3.5 mm (0.138 in)
Offroad tire pressure	
front	1.0 bar (15 psi)
rear	1.0 bar (15 psi)

Secondary ratio	14:49
Chain	5/8 x 1/4"
Rear sprockets available	48, 50, 52
Steering head angle	63.9°
Wheelbase	1,485 ± 10 mm (58.46 ± 0.39 in)
Seat height unloaded	950 mm (37.4 in)
Ground clearance unloaded	375 mm (14.76 in)
Weight without fuel, approx.	95.5 kg (210.5 lb.)
Maximum permissible front axle load	145 kg (320 lb.)
Maximum permissible rear axle load	190 kg (419 lb.)
Maximum permissible overall weight	335 kg (739 lb.)

20.6 Tires

Front tire	Rear tire
80/100 - 21 51M TT MAXXIS MAXXCROSS MX-ST+	100/90 - 19 57M TT MAXXIS MAXXCROSS MX-ST+
The tires specified represent one of the possible series production tires. Additional information is available in the Service section under: http://www.gasgas.com	

20.7 Fork

Fork article number	A540C103V406000
Fork	WP XACT AER
Compression damping	
Comfort	17 clicks
Standard	12 clicks
Sport	7 clicks
Rebound damping	
Comfort	23 clicks
Standard	18 clicks
Sport	13 clicks
Air pressure	10.4 bar (151 psi)
Fork length	950 mm (37.4 in)

Oil capacity external mechanism left	230 \pm $\frac{10}{50}$ ml (7.78 \pm $\frac{0.34}{-1.69}$ fl. oz.)	Fork oil (SAE 4) (48601166S1) (📖 p. 121)
Oil capacity external mechanism right	230 \pm $\frac{10}{50}$ ml (7.78 \pm $\frac{0.34}{-1.69}$ fl. oz.)	Fork oil (SAE 4) (48601166S1) (📖 p. 121)
Grease capacity, left cartridge	5 g (0.18 oz)	Special grease (00062010053) (📖 p. 123)
Oil capacity, right cartridge	380 ml (12.85 fl. oz.)	Fork oil (SAE 4) (48601166S1) (📖 p. 121)

20.8 Shock absorber

Shock absorber article number	18.18.7U.03
Shock absorber	WP XACT 5750
Lowspeed compression damping	
Comfort	17 clicks
Standard	15 clicks
Sport	13 clicks
Highspeed compression damping	
Comfort	2.5 turns
Standard	2 turns
Sport	1.5 turns
Rebound damping	
Comfort	17 clicks
Standard	15 clicks
Sport	13 clicks
Spring preload	7 mm (0.28 in)
Spring rate	
Weight of rider: 65 ... 75 kg (143 ... 165 lb.)	39 N/mm (223 lb/in)
Weight of rider: 75 ... 85 kg (165 ... 187 lb.)	42 N/mm (240 lb/in)
Weight of rider: 85 ... 95 kg (187 ... 209 lb.)	45 N/mm (257 lb/in)
Spring length	260 mm (10.24 in)
Gas pressure	10 bar (145 psi)
Static sag	35 mm (1.38 in)
Riding sag	105 mm (4.13 in)
Fitted length	477 mm (18.78 in)
Shock absorber fluid (📖 p. 121)	SAE 2.5

20.9 Chassis tightening torques

Hose clamp, radiator		2.4 Nm (1.77 lbf ft)
Screw, seat fixing	EJOT EJOFORM PT® K60x23/18	2.5 Nm (1.84 lbf ft)
Screw, stop button	M3	0.4 Nm (0.3 lbf ft)
Hose clip, inlet sleeve to carburetor	M4	2.8 Nm (2.07 lbf ft)
Screw, carburetor cover	M4	1.3 Nm (0.96 lbf ft)
Screw, fixed grip	M4	5 Nm (3.7 lbf ft)
		Loctite®243™
Spoke nipple, front wheel	M4.5	6 Nm (4.4 lbf ft)
Spoke nipple, rear wheel	M4.5	6 Nm (4.4 lbf ft)
Remaining nuts, chassis	M5	5 Nm (3.7 lbf ft)
Remaining screws, chassis	M5	5 Nm (3.7 lbf ft)
Screw, brake line guide on link fork	M5	5 Nm (3.7 lbf ft)
Screw, shock absorber adjusting ring	M5	5 Nm (3.7 lbf ft)
Screws on main silencer	M5	7 Nm (5.2 lbf ft)
Nut, carburetor cover on throttle cable wire	M6	3 Nm (2.2 lbf ft)
Remaining nuts, chassis	M6	10 Nm (7.4 lbf ft)
Remaining screws, chassis	M6	10 Nm (7.4 lbf ft)

Screw, absorbing element on frame	M6	6 Nm (4.4 lbf ft)	
Screw, absorbing element on manifold	M6	6 Nm (4.4 lbf ft)	
Screw, ball joint of push rod on foot brake cylinder	M6	10 Nm (7.4 lbf ft)	Loctite®243™
Screw, brake lever	M6	5 Nm (3.7 lbf ft)	
Screw, chain guide	M6	10 Nm (7.4 lbf ft)	
Screw, chain guide on link fork at the rear	M6	10 Nm (7.4 lbf ft)	Loctite®243™
Screw, chain sliding guard	M6	6 Nm (4.4 lbf ft)	Loctite®243™
Screw, clutch lever	M6	5 Nm (3.7 lbf ft)	
Screw, front brake disc	M6	14 Nm (10.3 lbf ft)	Loctite®243™
Screw, fuel tank spoiler on radiator	M6	6 Nm (4.4 lbf ft)	
Screw, rear brake disc	M6	14 Nm (10.3 lbf ft)	Loctite®243™
Screw, seat fixing	M6	6 Nm (4.4 lbf ft)	
Screw, throttle grip	M6	5 Nm (3.7 lbf ft)	
Nut, foot brake lever stop	M8	20 Nm (14.8 lbf ft)	
Nut, rear sprocket screw	M8	35 Nm (25.8 lbf ft)	Loctite®2701™
Nut, rim lock	M8	12 Nm (8.9 lbf ft)	
Remaining nuts, chassis	M8	25 Nm (18.4 lbf ft)	
Remaining screws, chassis	M8	25 Nm (18.4 lbf ft)	
Screw, bottom triple clamp	M8	15 Nm (11.1 lbf ft)	
Screw, chain sliding piece	M8	15 Nm (11.1 lbf ft)	
Screw, engine brace on engine	M8x20	25 Nm (18.4 lbf ft)	Loctite®243™
Screw, engine brace on frame	M8x15	25 Nm (18.4 lbf ft)	Loctite®2701™
Screw, engine sprocket cover	M8	15 Nm (11.1 lbf ft)	
Screw, fork stub	M8	15 Nm (11.1 lbf ft)	
Screw, front brake caliper	M8	25 Nm (18.4 lbf ft)	Loctite®243™
Screw, handlebar clamp	M8	20 Nm (14.8 lbf ft)	
Screw, manifold	M8	15 Nm (11.1 lbf ft)	
Screw, subframe bottom	M8x18	30 Nm (22.1 lbf ft)	Loctite®2701™
Screw, subframe top	M8x20	35 Nm (25.8 lbf ft)	Loctite®2701™
Screw, top steering stem	M8	20 Nm (14.8 lbf ft)	Loctite®243™
Screw, top triple clamp	M8	20 Nm (14.8 lbf ft)	
Engine bracket screw	M10	60 Nm (44.3 lbf ft)	
Remaining nuts, chassis	M10	45 Nm (33.2 lbf ft)	
Remaining screws, chassis	M10	45 Nm (33.2 lbf ft)	
Screw, bottom shock absorber	M10	60 Nm (44.3 lbf ft)	Loctite®2701™

Screw, handlebar support	M10	40 Nm (29.5 lbf ft)	Loctite®243™
Screw, top shock absorber	M10	60 Nm (44.3 lbf ft)	Loctite®2701™
Nut, angle lever to link fork	M14x1.5	60 Nm (44.3 lbf ft)	
Nut, frame on linkage lever	M14x1.5	60 Nm (44.3 lbf ft)	
Nut, linkage lever on angle lever	M14x1.5	60 Nm (44.3 lbf ft)	
Nut, fork pivot	M16x1.5	100 Nm (73.8 lbf ft)	
Screw, front wheel spindle	M20x1.5	35 Nm (25.8 lbf ft)	
Screw, top steering head	M20x1.5	12 Nm (8.9 lbf ft)	
Screw-in fitting, cooling system	M24x1.5	18 Nm (13.3 lbf ft)	Loctite®243™
Nut, rear wheel spindle	M25x1.5	80 Nm (59 lbf ft)	

Brake fluid DOT 4 / DOT 5.1

Standard/classification

- DOT

Guideline

- Use only brake fluid that complies with the specified standard (see specifications on the container) and that exhibits the corresponding properties.

Recommended supplier

Castrol

- REACT PERFORMANCE DOT 4

MOTOREX®

- Brake Fluid DOT 5.1

Coolant

Guideline

- Only use high-grade, silicate-free coolant with corrosion inhibitor additive for aluminum motors. Low grade and unsuitable antifreeze causes corrosion, deposits and frothing.
- Do not use pure water as only coolant is able to meet the requirements needed in terms of corrosion protection and lubrication properties.
- Only use coolant that complies with the requirements stated (see specifications on the container) and that has the relevant properties.

Antifreeze protection to at least	-25 °C (-13 °F)
-----------------------------------	-----------------

The mixture ratio must be adjusted to the necessary antifreeze protection. Use distilled water if the coolant needs to be diluted.

The use of premixed coolant is recommended.

Observe the coolant manufacturer specifications for antifreeze protection, dilution and miscibility (compatibility) with other coolants.

Recommended supplier

MOTOREX®

- COOLANT M3.0

Engine oil (15W/50)

Standard/classification

- JASO T903 MA2 (📖 p. 124)
- SAE (📖 p. 124) (15W/50)

Guideline

- Use only engine oils that comply with the specified standards (see specifications on the container) and that possess the corresponding properties.

Recommended supplier

MOTOREX®

- Top Speed 4T

Engine oil, 2-stroke

Standard/classification

- JASO FD (📖 p. 124)

Guideline

- Only use high-grade 2-stroke engine oil from a reputable brand.

fully synthetic

Recommended supplier

MOTOREX®

- Cross Power 2T

Fork oil (SAE 4) (48601166S1)**Standard/classification**

- SAE (📖 p. 124) (SAE 4)

Guideline

- Use only oils that comply with the specified standards (see specifications on the container) and that exhibit the corresponding properties.

Shock absorber fluid (SAE 2.5) (50180751S1)**Standard/classification**

- SAE (📖 p. 124) (SAE 2.5)

Guideline

- Use only oils that comply with the specified standards (see specifications on the container) and that exhibit the corresponding properties.

Super unleaded (ROZ 95)**Standard/classification**

- DIN EN 228 (ROZ 95)

Guideline

- Only use super unleaded fuel that matches or is equivalent to the specified standard.
- Fuel with an ethanol content of up to 10% (E10 fuel) is safe to use.

**Info**

Do **not** use fuel containing methanol (e.g., M15, M85, M100) or more than 10% ethanol (e.g., E15, E25, E85, E100).

Super unleaded (95 octane) mixed with 2-stroke engine oil (1:60)**Standard/classification**

- DIN EN 228
- JASO FD (📖 p. 124) (1:60)

Mixture ratio

1:60	Engine oil, 2-stroke (📖 p. 120) Super unleaded (ROZ 95) (📖 p. 121)
------	---

Recommended supplier**MOTOREX®**

- **Cross Power 2T**

Air filter cleaner

Recommended supplier

MOTOREX®

- Racing Bio Dirt Remover

Chain cleaner

Recommended supplier

MOTOREX®

- Chain Clean

Fuel additive

Recommended supplier

MOTOREX®

- Fuel Stabilizer

High viscosity grease

Recommended supplier

SKF®

- LGHB 2

Long-life grease

Recommended supplier

MOTOREX®

- Bike Grease 2000

Motorcycle cleaner

Recommended supplier

MOTOREX®

- Moto Clean

Off-road chain spray

Recommended supplier

MOTOREX®

- Chainlube Offroad

Oil for foam air filter

Recommended supplier

MOTOREX®

- Racing Bio Liquid Power

Preserving materials for paints, metal and rubber

Recommended supplier

MOTOREX®

- Moto Protect

Special cleaner for glossy and matte paint finishes, metal and plastic surfaces

Recommended supplier

MOTOREX®

- Quick Cleaner

Special grease (00062010053)

Recommended supplier

Klüber Lubrication®

– KLÜBERFOOD NH1 34-401

Universal oil spray

Recommended supplier

MOTOREX®

– Joker 440 Synthetic

JASO T903 MA2

Different technical development directions required a separate specification for motorcycles – the **JASO T903 MA2** standard.

Earlier, engine oils from the automobile industry were used for motorcycles because there was no separate motorcycle specification.

Whereas long service intervals are demanded for automobile engines, the focus for motorcycle engines is on high performance at high engine speeds.

In most motorcycle engines, the transmission and clutch are lubricated with the same oil.

The **JASO T903 MA2** standard meets these special requirements.

SAE

The SAE viscosity classes were defined by the Society of Automotive Engineers and are used for classifying oils according to their viscosity. The viscosity describes only one property of oil and says nothing about quality.

JASO FD

JASO FD is a classification for a 2-stroke engine oil that was specifically developed for the extreme demands of racing.

Thanks to first-rate synthetic esters and specially designed additives, superb combustion is achieved even under extreme operating conditions.

Art. no.	Article number
ca.	circa
cf.	compare
e.g.	for example
etc.	et cetera
i.a.	inter alia
no.	number
poss.	possibly

A	
Accessories	9
Air filter	
cleaning	56
installing	57
removing	56
Air filter box	
cleaning	56
Air filter box cover	
installing	55
preparing for securing	57
removing	54
Air suspension XACT 5448	32
Antifreeze	
checking	88
Auxiliary substances	9
B	
Basic chassis setting	
rider's weight, checking with	32
Brake discs	
checking	71
Brake fluid	
front brake, adding	72
rear brake, adding	78
Brake fluid level	
front brake, checking	72
rear brake, checking	77
Brake linings	
front brake, checking	74
of the front brake, changing	74
of the rear brake, changing	79
rear brake, checking	79
C	
Capacity	
coolant	115
gear oil	104, 115
Carburetor	
float chamber, emptying	102
idle setting	97
idle speed, adjusting	98
Carburetor tuning	95
Chain	
checking	64
cleaning	62
Chain guide	
checking	64
Chain tension	
adjusting	63
checking	62
Choke	16
Clutch	
fluid level, checking/correcting	68
fluid, changing	69
Clutch lever	14
basic position, adjusting	68
Compression damping	
fork, adjusting	39
Coolant	
changing	92
draining	89
refilling	90
Coolant level	
checking	88-89
Cooling system	88
Customer service	9
D	
Defined use	6
Difficult operating conditions	19
dry sand	20
high temperatures	23
low temperature	24
muddy surfaces	22
slow speed	23
snow	24
wet sand	21
wet surfaces	22
E	
Engine	
running in	19
Engine characteristic	
auxiliary spring, adjusting	100
Engine number	12
Engine sprocket	
checking	64
Environment	8
F	
Figures	9
Filling up	
fuel	28
Foot brake lever	17
basic position, adjusting	77
free travel, checking	76
Fork	
air pressure, adjusting	38
article number	12
basic setting, checking	38
Fork legs	
bleeding	42
dust boots, cleaning	43
installing	44
removing	43

Fork protector	
installing	45
removing	45
Frame	
checking	66
Front fender	
installing	50
removing	50
Front wheel	
installing	83
removing	82
Fuel tank	
installing	60
removing	59
Fuel tank filler cap	
closing	15
opening	15
Fuel tap	16
Fuel, oils, etc.	9
G	
Gear oil	
adding	104
changing	103
Gear oil level	
checking	103
H	
Hand brake lever	14
basic position, adjusting	71
free travel, checking	71
Handlebar position	40
adjusting	40
High-speed compression damping	
shock absorber, adjusting	33
I	
Ignition timing map	
changing	99
plug-in connector	99
Implied warranty	9
Intended use	6
K	
Kick starter lever	17
L	
Link fork	
checking	66
Lower triple clamp	
installing	46
removing	45
Low-speed compression damping	
shock absorber, adjusting	33

M	
Main silencer	
glass fiber yarn filling, changing	58
installing	58
removing	58
Manufacturer warranty	9
Misuse	6
Motorcycle	
cleaning	106
from lift stand, removing	42
raising with lift stand	42
O	
Owner's Manual	8
P	
Play in throttle cable	
adjusting	94
checking	94
Plug-in stand	17
Preparing for use	
advice on preparing for first use	18
after storage	109
checks and maintenance measures when preparing for use	25
Protective clothing	7
R	
Rear sprocket	
checking	64
Rear wheel	
installing	84
removing	83
Rebound damping	
fork, adjusting	40
shock absorber, adjusting	34
Riding sag	
adjusting	37
Rubber grip	
checking	67
S	
Safe operation	7
Seat	
mounting	54
removing	53
Service	9
Shift lever	16
basic position, adjusting	99
basic position, checking	99
Shock absorber	
article number	13
compression damping, general	33
installing	52
removing	50

riding sag, checking	36
spring preload, adjusting	36
static sag, checking	35
Spare parts	9
Spoke tension	
checking	87
Start number plate	
installing	49
removing	49
Starting	25
Steering head bearing	
lubricating	49
Steering head bearing play	
adjusting	48
checking	48
Stop button	14
Storage	108
T	
Technical data	
capacities	115
carburetor	114
chassis	115
chassis tightening torques	117
engine	112
engine tightening torques	112
fork	116
shock absorber	117
tires	116
Throttle cable routing	
checking	66
Throttle grip	14
Tire condition	
checking	86
Tire pressure	
checking	86
Transporting	28
Troubleshooting	110-111
Type label	12
V	
Vehicle identification number	12
View of vehicle	
front left	10
rear right	11
W	
Work rules	8



3215074en

09/2021



Stallhofnerstraße 3 / 5230 Mattighofen / Austria / <http://www.gasgas.com>

