

OWNER'S MANUAL 2021



EE 5

Art. no. 3402438en



DEAR HUSQVARNA MOTORCYCLES CUSTOMER

Congratulations on your decision to purchase a Husqvarna motorcycle. You are now the owner of a state-of-the-art sports vehicle that will continue to give you and your child pleasure for a long time if you maintain it properly.

We hope your child has many safe and enjoyable rides!

Enter the serial numbers of your vehicle below.

Vehicle identification number (📖 p. 14)	Dealer's stamp
Motor number (📖 p. 14)	

Read through this Owner's Manual carefully, always exercise caution when using the vehicle, and contact an authorized Husqvarna Motorcycles workshop if you have any questions.

This Owner's Manual serves as a technical instruction manual, explains important safety matters, and provides an overview of the main functions. This Owner's Manual is only intended for personal use. This Owner's Manual is not intended for commercial use.

The Owner's Manual contained the latest information for this model series at the time of going to print. However, minor differences due to further developments in design cannot be ruled out completely.

All specifications contained herein are non-binding. Husqvarna Motorcycles GmbH specifically reserves the right to modify or delete technical specifications, prices, colors, forms, materials, services, designs, equipment, etc., without prior notice and without specifying reasons, to adapt these to local conditions, as well as to stop production of a particular model without prior notice. Husqvarna Motorcycles accepts no liability for delivery options, deviations from illustrations and descriptions, as well as misprints and other errors. The models portrayed partly contain special equipment that does not belong to the regular scope of supply.

© 2020 Husqvarna Motorcycles GmbH, Mattighofen Austria

All rights reserved

Reproduction, even in part, as well as copying of all kinds, is permitted only with the express written permission of the copyright owner.



ISO 9001(12 100 6061)

Husqvarna Motorcycles applies quality assurance processes that lead to the highest possible product quality as defined in the ISO 9001 international quality management standard.

Issued by: TÜV-Management Service

REG.NO. 12 100 6061

Husqvarna Motorcycles GmbH
Stallhofnerstraße 3
5230 Mattighofen, Austria

This document is valid for the following models:

EE 5 (F3001U7)



3402438en

05/2020

TABLE OF CONTENTS

1	MEANS OF REPRESENTATION.....	5	7	MULTIFUNCTIONAL ELEMENT.....	19
1.1	Symbols used	5	7.1	Multifunctional element.....	19
1.2	Formats used.....	5	7.2	Ride mode button	19
2	SAFETY ADVICE	6	7.3	Ride mode display	20
2.1	Use definition – intended use	6	7.4	Malfunction indicator lamp	20
2.2	Misuse.....	6	7.5	Charging level indicator	20
2.3	Notes/warnings.....	6	7.6	Power reduction.....	21
2.4	Grades of risks.....	6	8	PREPARING FOR USE.....	22
2.5	Tampering warning	6	8.1	Advice on preparing for first use.....	22
2.6	Safe operation.....	7	9	RIDING INSTRUCTIONS	24
2.7	Fall or accident	8	9.1	Checks and maintenance measures when preparing for use	24
2.8	Protective clothing	8	9.2	Starting the vehicle	24
2.9	Work on vehicle, motor, and rechargeable lithium-ion battery	8	9.3	Starting off	25
2.10	Environment.....	8	9.4	Applying the brakes	25
2.11	Owner's Manual	9	9.5	Recuperation.....	26
2.12	Fire hazard	9	9.6	Stop, park	26
3	IMPORTANT NOTES.....	10	9.7	Transporting.....	27
3.1	Manufacturer warranty, implied warranty	10	10	SERVICE SCHEDULE.....	28
3.2	Fuel, auxiliary substances.....	10	10.1	Additional information.....	28
3.3	Spare parts, accessories	10	10.2	Required work.....	28
3.4	Service	10	10.3	Recommended work.....	29
3.5	Figures	10	11	SUSPENSION SETTING.....	30
3.6	Customer service.....	10	11.1	Checking the basic chassis setting with the rider's weight.....	30
3.7	Power supply	11	11.2	Air suspension XACT 5235	30
3.8	Operation at low temperatures	11	11.3	Compression damping of the shock absorber.....	31
4	VIEW OF VEHICLE	12	11.4	Adjusting the low-speed compression damping of the shock absorber.....	31
4.1	View of vehicle, front left (example)	12	11.5	Adjusting the high-speed compression damping of the shock absorber.....	32
4.2	View of vehicle, rear right (example).....	13	11.6	Adjusting the rebound damping of the shock absorber	32
5	SERIAL NUMBERS.....	14	11.7	Measuring the dimension of the rear wheel unloaded.....	33
5.1	Vehicle identification number.....	14	11.8	Checking the static sag of the shock absorber	34
5.2	Type label.....	14	11.9	Checking the riding sag of the shock absorber	34
5.3	Motor number	14	11.10	Adjusting the spring preload of the shock absorber 🏍.....	35
5.4	Fork part number	14	11.11	Adjusting the riding sag 🏍.....	36
5.5	Shock absorber article number	15	11.12	Checking the basic setting of the fork.....	36
5.6	Battery identification number.....	15	11.13	Adjusting the fork air pressure.....	37
6	CONTROLS	16			
6.1	Hand brake lever.....	16			
6.2	Throttle grip.....	16			
6.3	On/Off button.....	16			
6.4	Magnetic switch on handlebar.....	16			
6.5	Magnetic switch under the seat.....	17			
6.6	Foot brake lever	17			
6.7	Plug-in stand.....	18			
6.8	Diagnostics connector	18			

11.14	Adjusting the rebound damping of the fork.....	38	14	BRAKE SYSTEM	62
11.15	Handlebar position.....	38	14.1	Checking play of handbrake lever	62
11.16	Adjusting the handlebar position 🛠️.....	39	14.2	Adjusting the play of the hand brake lever	62
12	SEAT HEIGHT	40	14.3	Adjusting the basic position of the hand brake lever	62
12.1	Seat height adjustment options.....	40	14.4	Checking the brake discs	63
12.2	Adjusting the seat height on the shock absorber 🛠️.....	40	14.5	Checking the front brake fluid level	64
12.3	Adjusting the seat height on the fork 🛠️.....	41	14.6	Adding front brake fluid 🛠️.....	65
12.4	Adjusting the seat height on the frame 🛠️.....	42	14.7	Checking the front brake linings	66
13	SERVICE WORK ON THE CHASSIS	45	14.8	Changing the brake linings of the front brake 🛠️.....	66
13.1	Raising the motorcycle with a lift stand	45	14.9	Checking the free travel of the foot brake lever	69
13.2	Removing the motorcycle from the lift stand	45	14.10	Adjusting the free travel of the foot brake lever 🛠️.....	69
13.3	Bleeding the fork legs	45	14.11	Adjusting the basic position of the foot brake lever 🛠️.....	70
13.4	Cleaning the dust boots of the fork legs	46	14.12	Checking the rear brake fluid level	71
13.5	Removing the fork protector.....	46	14.13	Adding rear brake fluid 🛠️.....	71
13.6	Installing the fork protector.....	47	14.14	Checking the brake linings of the rear brake.....	72
13.7	Removing the fork legs 🛠️.....	47	14.15	Changing the rear brake linings 🛠️.....	73
13.8	Installing the fork legs 🛠️.....	47	15	WHEELS, TIRES	76
13.9	Removing the lower triple clamp 🛠️	48	15.1	Removing the front wheel 🛠️.....	76
13.10	Installing the lower triple clamp 🛠️.....	49	15.2	Installing the front wheel 🛠️.....	76
13.11	Checking the steering head bearing play	51	15.3	Removing the rear wheel 🛠️.....	77
13.12	Adjusting the steering head bearing play 🛠️.....	52	15.4	Installing the rear wheel 🛠️.....	78
13.13	Lubricating the steering head bearing 🛠️.....	52	15.5	Checking the tire condition.....	79
13.14	Removing the start number plate	53	15.6	Checking tire pressure.....	80
13.15	Installing the start number plate	53	15.7	Checking spoke tension	80
13.16	Removing front fender	53	16	POWERPACK LV, BATTERY CHARGER	82
13.17	Installing front fender	54	16.1	Overview of battery charger	82
13.18	Removing the shock absorber 🛠️.....	54	16.2	Positioning the battery charger.....	82
13.19	Installing the shock absorber 🛠️.....	54	16.3	Charging the Powerpack LV.....	83
13.20	Removing the seat.....	55	17	COOLING	87
13.21	Mounting the seat.....	55	17.1	Cooling.....	87
13.22	Checking the chain for dirt.....	56	18	CLEANING, CARE.....	88
13.23	Cleaning the chain	56	18.1	Cleaning the motorcycle.....	88
13.24	Checking the chain tension	57	19	STORAGE.....	90
13.25	Adjusting the chain tension.....	57	19.1	Storage	90
13.26	Checking the chain, rear sprocket, motor sprocket, and chain guide.....	58	19.2	Preparing for use after storage	90
13.27	Adjusting the chain guide 🛠️.....	60	20	TROUBLESHOOTING	91
13.28	Checking the frame 🛠️.....	60	21	TECHNICAL DATA	93
13.29	Checking the link fork 🛠️.....	61	21.1	Engine	93
13.30	Checking the rubber grip	61	21.2	Chassis	93

TABLE OF CONTENTS

21.3	Electrical system.....	94
21.4	Tires	94
21.5	Fork.....	94
21.6	Shock absorber	95
21.7	Chassis tightening torques	95
22	SUBSTANCES.....	98
23	AUXILIARY SUBSTANCES.....	99
24	STANDARDS	100
25	INDEX OF SPECIAL TERMS	101
26	LIST OF ABBREVIATIONS	102
27	LIST OF SYMBOLS	103
27.1	Yellow and orange symbols.....	103
	INDEX	104

1.1 Symbols used

The meaning of specific symbols is described below.



Indicates an expected reaction (e.g., of a work step or a function).



Indicates an unexpected reaction (e.g., of a work step or a function).



All work marked with this symbol requires specialist knowledge and technical understanding. In the interest of the safety of your child, have these jobs performed in an authorized Husqvarna Motorcycles workshop. Your motorcycle will be optimally cared for there by specially trained experts using the special tools required.



Indicates a page reference (more information is provided on the specified page).



Indicates information with more details or tips.



Indicates the result of a testing step.



Indicates the end of an activity, including potential reworking.



Indicates a voltage measurement.



Indicates a current measurement.

1.2 Formats used

The typographical formats used in this document are explained below.

Proprietary name

Indicates a proprietary name.

Name[®]

Indicates a protected name.

Brand[™]

Indicates a brand available on the open market.

Underlined terms

Refer to technical details of the vehicle or indicate technical terms, which are explained in the glossary.

2 SAFETY ADVICE

2.1 Use definition – intended use

This vehicle is designed and constructed to withstand the stresses and strains of regular racing if the maximum rider weight is not exceeded.

Info

Only operate this vehicle in closed-off areas remote from public road traffic.
Only use the lithium-ion battery while it is inside the vehicle.

2.2 Misuse

The vehicle must only be used as intended.

Dangers can arise for people, property and the environment through use not as intended.

Any use of the vehicle beyond the intended and defined use constitutes misuse.

Misuse also includes the use of operating and auxiliary fluids which do not meet the required specification for the respective use.

2.3 Notes/warnings

Pay close attention to the notes/warnings.

Info

Various information and warning labels are affixed to the vehicle. Do not remove information/warning labels. If they are missing, you or others may not recognize dangers and may therefore be injured.

2.4 Grades of risks



Warning

Identifies a danger that is likely to lead to fatal or serious injury if the appropriate measures are not taken.



Caution

Identifies a danger that may lead to minor injuries if the appropriate measures are not taken.

Note

Identifies a danger that will lead to considerable machine and material damage if the appropriate measures are not taken.



Warning

Identifies a danger that will lead to environmental damage if the appropriate measures are not taken.

2.5 Tampering warning

No mechanical, electrical or electronic modifications may be made to the vehicle, since safe operation cannot be guaranteed otherwise.

Examples of inadmissible manipulation and modifications:

- 1 Opening the rechargeable lithium-ion battery (Powerpack LV) or the motor.
- 2 Using the vehicle or the rechargeable lithium-ion battery when proper maintenance has not been performed.
- 3 Using the vehicle or the rechargeable lithium-ion battery outside of its defined use.
- 4 Using a damaged lithium-ion battery.

2.6 Safe operation



Warning

Danger of accidents A lack of physical and mental readiness on the part of the child poses a major risk.

Children often underestimate or fail to recognize dangerous situations.

- Your child must already be able to ride a bicycle.
- Your child must be able to put the vehicle upright independently after a fall.
- Your child must understand that regulations and instructions from you or from other guardians must be followed.
- Make it clear to your child that he or she should not, under any circumstances, operate the vehicle without supervision.
- Make sure that the ride mode is appropriate for your child's riding ability and for the riding conditions.
If necessary, block the ride mode by removing the magnetic switch under the seat.
- Do not ask too much of your child.
Do not consider participation in competitive activities until your child's stamina, riding techniques and motivation are at the necessary levels.
- Only let your child ride on the vehicle if he or she is physically and mentally ready.



Warning

Danger of burns Some vehicle components become very hot when the vehicle is operated.

- Do not touch any parts such as the motor, lithium-ion battery, damper, or brake system before these vehicle parts have cooled down.
- Let the vehicle parts cool down before you perform any work on the vehicle.

This vehicle is a low-voltage electric motorcycle. For this reason, follow the safety and care instructions that apply when using an electric motor.

If the throttle grip is closed and no recuperation (🔊 p. 26) is activated, the vehicle continues to roll without much delay. The vehicle speed decreases on account of rolling resistance and air resistance.

Because this vehicle does not have a manual transmission, there is no clutch.

As with a conventional drive with a combustion engine, the operating temperature rises according to use and depending on the ambient temperature and the cleanliness of the cooling surfaces. If the temperature of the motor, the lithium-ion battery, or the electronics rises above the permissible operating temperature, the power of the vehicle will be reduced considerably. This protects the system against damage from overheating. When power reduction is imminent, the active driving mode indicator flashes. When power reduction is active, all three driving mode indicators light up. When all components have returned to their normal operating temperature, full system power is restored after restarting.

Only operate the vehicle when it is in perfect technical condition, in accordance with its intended use, and in a safe and environmentally compatible manner.

Have malfunctions that impair safety promptly eliminated by an authorized KTM workshop.

Adhere to the information and warning labels on the vehicle.

2.7 Fall or accident

If the vehicle is lying on its side, it switches from ready mode to standby mode after five seconds. To return the vehicle to ready mode, place the vehicle in the upright position and close the throttle grip beyond the basic position.

After a fall or accident, check the vehicle as usual when preparing for use.

2.8 Protective clothing



Warning

Risk of injury Missing or poor protective clothing presents an increased safety risk.

- Ensure your child wears appropriate protective clothing such as helmet, boots, gloves as well as trousers and a jacket with protectors on all rides.
- Always use protective clothing for your child that is in good condition and meets the legal requirements.
- When you ride a motorcycle, set an example for your child and wear suitable protective clothing.

2.9 Work on vehicle, motor, and rechargeable lithium-ion battery



Warning

Risk of injury There is a risk of electric shock when working on live components.

Work on live components requires special training, qualifications, and tools.

- Have all work that is not described and explained performed by trained Husqvarna Motorcycles mechanics only.
- Do not open the electric motor or the lithium-ion battery (Powerpack LV).



Warning

Risk of injury The vehicle runs very quietly, even when it is ready to operate.

The vehicle starts moving in an uncontrolled manner if the throttle grip is accidentally touched while work is being performed on the vehicle.

- Ensure that the vehicle is switched off with the On/Off button and remains switched off before starting any work on the vehicle.
- Remove the magnetic switch from the holder before starting any work on the vehicle.
- Protect the vehicle against access by unauthorized persons while you are performing work on the vehicle.

2.10 Environment

When you respect the rights of others and use your motorcycle legally, you will help protect the future of motorcycle sport and avoid most conflicts and problems.

When disposing of used oil, other operating and auxiliary fluids, and used components, comply with the applicable laws and regulations in your country.

When disposing of the lithium-ion battery (Powerpack LV), observe the relevant laws and guidelines of your country.

Your authorized Husqvarna Motorcycles dealer can dispose of the Powerpack LV free of charge and in an environmentally compatible manner.

Because motorcycles are not subject to the EU regulations governing the disposal of used vehicles, there are no legal regulations that pertain to the disposal of an end-of-life motorcycle. Your authorized Husqvarna Motorcycles dealer will be glad to advise you.

Electrical devices like the battery charger may not be disposed of with household waste. Electrical devices must be disposed of through the appropriate recycling centers. Contact your municipality or your authorized Husqvarna Motorcycles dealer.

2.11 Owner's Manual

It is important that you read this Owner's Manual carefully and completely before your child makes his or her first trip. The Owner's Manual contains useful information and many tips for you and your child on how to operate, handle, and service your motorcycle. This is the only way for you to find out how to ideally tune the vehicle and how to protect your child from injury.

Keep the Owner's Manual in an accessible place to enable you to refer to it as needed.

If you would like to know more about the vehicle or have questions on the material you read, please contact an authorized Husqvarna Motorcycles dealer.

The Owner's Manual is an important component of the vehicle and must be handed over to the new owner if the vehicle is sold.

The Owner's Manual is also available for download from your authorized Husqvarna Motorcycles dealer and on the Husqvarna Motorcycles website.

International Husqvarna Motorcycles website: www.husqvarna-motorcycles.com

2.12 Fire hazard



Warning

Fire hazard Damaged rechargeable lithium-ion batteries present a fire hazard.

Massive mechanical damage may cause an internal cell short circuit and as a consequence may cause the battery to self-ignite.

- Contact Husqvarna Motorcycles customer service immediately if major damage to the rechargeable lithium-ion battery has occurred.

There is no particular fire hazard for this vehicle when the rechargeable lithium-ion battery (Powerpack LV) is intact.

However, should the vehicle catch fire, inform the fire department responsible that an electric vehicle with a rechargeable lithium-ion battery is on fire.

3 IMPORTANT NOTES

3.1 Manufacturer warranty, implied warranty

The work prescribed in the service schedule must only be carried out in an authorized Husqvarna Motorcycles workshop and confirmed in the **Husqvarna Motorcycles Dealer.net**, as otherwise all warranty claims will be void. Damage or secondary damage caused by tampering with and/or conversions on the vehicle are not covered by the manufacturer warranty.

3.2 Fuel, auxiliary substances

Use the operating and auxiliary substances (such as oils and lubricants) specified in the Owner's Manual.

3.3 Spare parts, accessories

For the safety of your child, only use spare parts and accessory products that are approved and/or recommended by Husqvarna Motorcycles and have them installed by an authorized Husqvarna Motorcycles workshop. Husqvarna Motorcycles accepts no liability for other products and any resulting damage or loss. Certain spare parts and accessory products are specified in parentheses in the descriptions. Your authorized Husqvarna Motorcycles dealer will be glad to advise you.

The current **Husqvarna Motorcycles** accessories for your vehicle can be found on the Husqvarna Motorcycles website.

International Husqvarna Motorcycles website: www.husqvarna-motorcycles.com

3.4 Service

A prerequisite for perfect operation and prevention of premature wear is that the service, care, and tuning work is properly carried out as described in the Owner's Manual. An incorrect suspension setting can lead to damage and breakage of chassis components.

Use of the vehicle under difficult conditions, such as on sand or on wet and muddy surfaces, can result in significantly increased wear of components, such as the drive train, brake system, or suspension components. For this reason, it may be necessary to inspect or replace parts before the next scheduled service.

It is imperative that you adhere to the stipulated service intervals. If you observe these exactly, you will ensure a much longer service life for your motorcycle.

The relevant mileage or time interval is whichever occurs first.

3.5 Figures

The figures contained in the manual may depict special equipment.

In the interest of clarity, some components may be shown disassembled or may not be shown at all. It is not always necessary to disassemble the component to perform the activity in question. Please follow the instructions in the text.

3.6 Customer service

Your authorized Husqvarna Motorcycles dealer will be happy to answer any questions you may have regarding your vehicle and Husqvarna Motorcycles.

A list of authorized Husqvarna Motorcycles dealers can be found on the Husqvarna Motorcycles website. International Husqvarna Motorcycles website: www.husqvarna-motorcycles.com

3.7 Power supply



A rechargeable lithium-ion battery **1** (Powerpack LV) is installed in the vehicle.
 The Powerpack LV supplies electric motor **2** and multifunctional element **3** with voltage.
 The Powerpack LV is firmly bolted to the frame and motor.

3.8 Operation at low temperatures

In order to protect the Powerpack LV, the motor control reduces the power at low component temperatures. If the temperature of the Powerpack LV is too low, the active ride mode indicator flashes. The vehicle can continue to be operated. The Powerpack LV is not damaged by the power reduction. The Powerpack LV heats up when the vehicle is in operation. When the temperature of the Powerpack LV exceeds a threshold value, full vehicle power is restored after the vehicle is restarted.

4 VIEW OF VEHICLE

4.1 View of vehicle, front left (example)



M01715-10

- ❶ Hand brake lever (📖 p. 16)
- ❷ Magnetic switch under the seat (📖 p. 17)
- ❸ Plug-in stand holder
- ❹ Charging socket

4.2 View of vehicle, rear right (example)



M01716-10

- ❶ Quick release of seat
- ❷ Multifunction element (📖 p. 19)
- ❸ Magnetic switch on handlebar (📖 p. 16)
- ❹ Throttle grip (📖 p. 16)
- ❺ Vehicle identification number (📖 p. 14)
- ❻ On/Off button (📖 p. 16)
- ❼ Foot brake lever (📖 p. 17)
- ❽ Level viewer for brake fluid, rear

5 SERIAL NUMBERS

5.1 Vehicle identification number

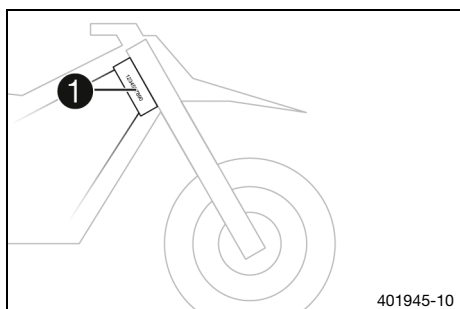

The vehicle identification number ① is stamped on the right side of the steering head.

5.2 Type label

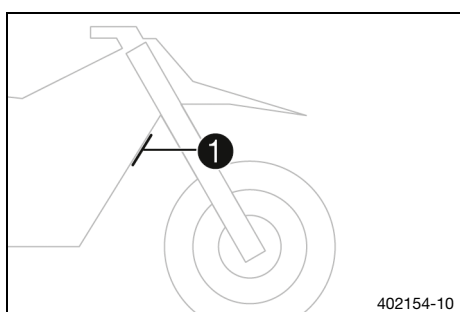

The type label ① is located on the front frame tube.

5.3 Motor number

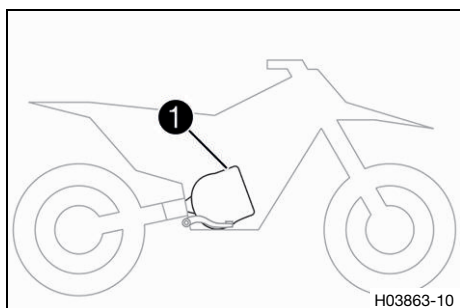

The motor number ① is located on the right side of the motor below the Powerpack LV.

5.4 Fork part number

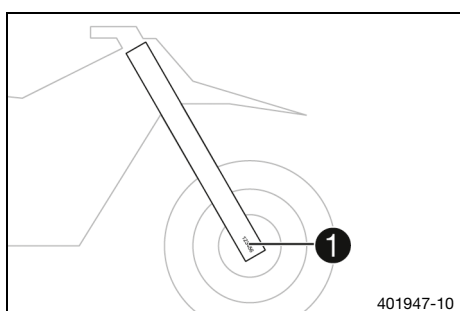

The fork part number ① is stamped on the outside of the axle clamp.

5.5 Shock absorber article number

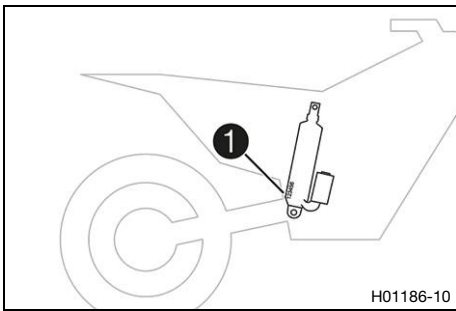

The shock absorber article number **1** is stamped on the bottom of the shock absorber toward the right-hand side.

5.6 Battery identification number

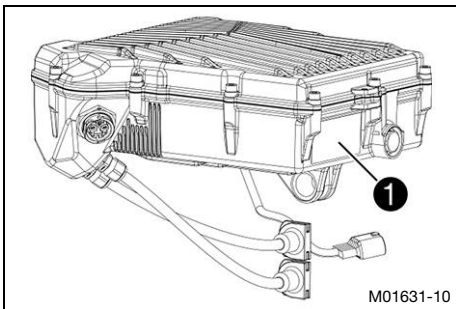

The battery identification number (**BIN**) **1** is located on a sticker on the Powerpack LV.

6.1 Hand brake lever

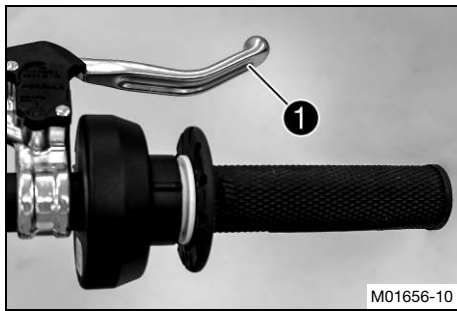

Hand brake lever **1** is fitted on the right side of the handlebar. The hand brake lever is used to activate the front brake.

6.2 Throttle grip

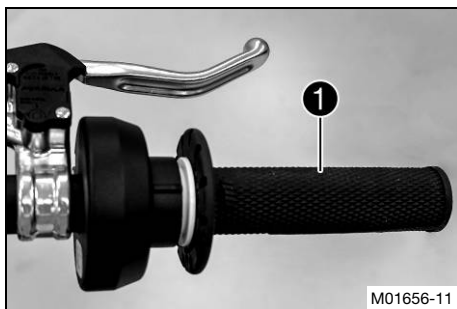

The throttle grip **1** is fitted on the right side of the handlebar. After activation, the vehicle initially does not react to the throttle grip to prevent accidental acceleration. The throttle grip must be closed beyond the basic position to activate the throttle response. Only then does the vehicle switch to ready mode.

6.3 On/Off button



The On/Off button **1** is located on the right side of the Powerpack LV.

Possible states

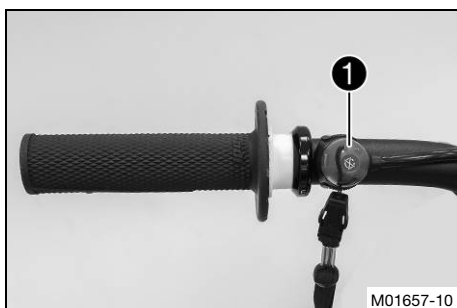

- Vehicle switched off – In this operating state, the vehicle is deactivated.
- Vehicle in standby mode – In this operating state, the vehicle is activated.

6.4 Magnetic switch on handlebar



The holder for the red magnetic switch **1** is located on the left side of the handlebar.

Possible states

- Magnetic switch  mounted on handlebar – When the magnetic switch is mounted on the handlebar, the vehicle can be activated and ridden.
- Magnetic switch  removed from handlebar – When the magnetic switch is removed from the handlebar, the vehicle cannot be activated or ridden.



Warning

Risk of injury If the magnetic switch remains in the holder during a fall, the vehicle is not immediately deactivated.

- Make sure that the loop of the magnetic switch is securely attached to the user's protective clothing or wrist so that the magnetic switch is disconnected from the holder in the event of a fall.

If the red magnetic switch on the handlebar is disconnected from the holder, e.g., in the event of a fall, the vehicle is deactivated. By removing the red magnetic switch from the handlebar, the vehicle can be quickly deactivated in any operating state. The red magnetic switch on the handlebar cannot be replaced with the gray magnetic switch under the seat (📖 p. 17).

6.5 Magnetic switch under the seat

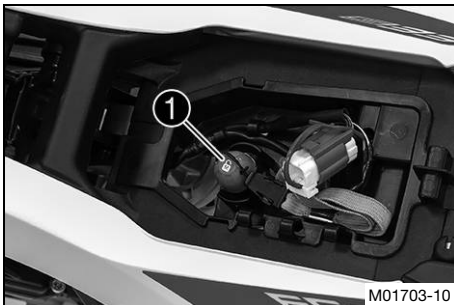



The holder for the gray magnetic switch ❶ is located under the seat.

By removing the gray magnetic switch under the seat, you can prevent the ride mode from being changed.

Locking the ride mode is recommended if you have not yet gained sufficient experience for higher ride modes with more power and torque.

Possible states

- Magnetic switch  mounted under the seat – When the magnetic switch is mounted under the seat, the ride mode can be changed.
- Magnetic switch  removed – When the magnetic switch under the seat is removed, the ride mode cannot be changed.

The gray magnetic switch under the seat cannot be replaced with the red magnetic switch on the handlebar (📖 p. 16).

6.6 Foot brake lever

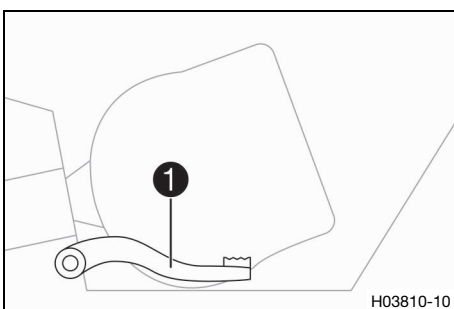

Foot brake lever ❶ is located in front of the right footrest. The rear brake is engaged with the foot brake lever.

6.7 Plug-in stand

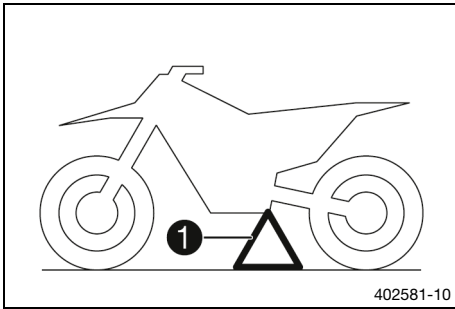

The fixture for plug-in stand **1** is located on the frame on the left side of the vehicle.
The plug-in stand is used to park the motorcycle.



Info

Remove the plug-in stand before riding.

6.8 Diagnostics connector

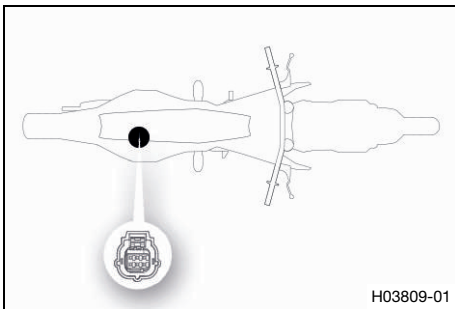

Diagnostics connector **1** is located under the seat.

7.1 Multifunctional element

The multifunctional element is mounted in front of the seat.

Overview of multifunctional element

- ❶ Ride mode button (📖 p. 19)
- ❷ Ride mode display (📖 p. 20)
- ❸ Malfunction indicator lamp (📖 p. 20)
- ❹ Charging level indicator (📖 p. 20)

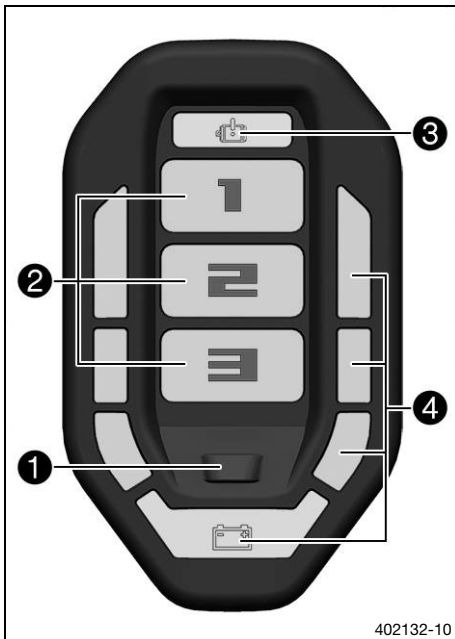

7.2 Ride mode button

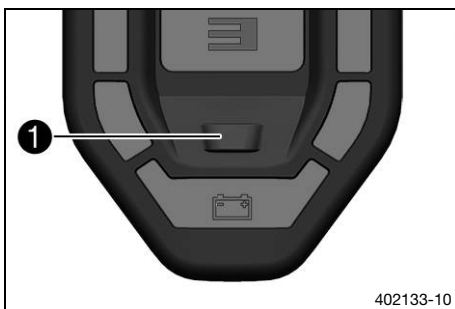

The ride mode button ❶ determines the ride mode (📖 p. 20). The ride mode button is only active if the magnetic switch under the seat 🔒 (📖 p. 17) is mounted.

Possible states

- The vehicle is in standby mode – The ride mode button is active.
- The vehicle is in ready mode – The ride mode button is active.
- All other vehicle conditions – The ride mode button is not active.

7.3 Ride mode display

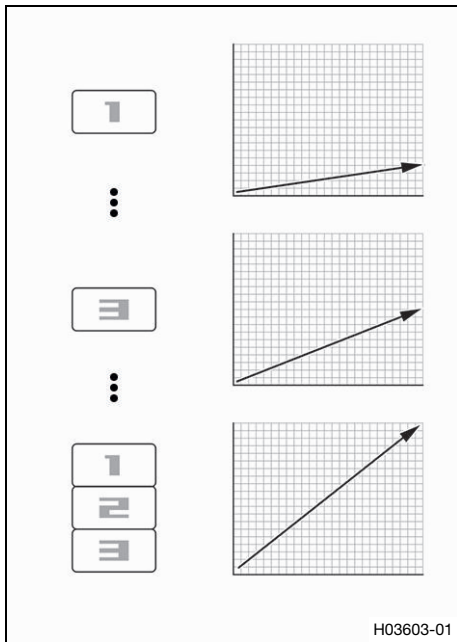

Red ride mode displays with the numbers **1**, **2**, or **3** show the ride mode selected.

Six ride modes are available. The ride modes define how the vehicle will respond to operation of the throttle grip.

The lowest torque is available in ride mode **1**. The maximum speed of the vehicle is limited. This ride mode is suitable for familiarization.

In ride modes **5** and **6**, the full torque is available. The maximum speed of the vehicle can be utilized. These ride modes should only be selected once sufficient riding experience has been gained and the vehicle can be handled safely.

The ride modes between **1** and **5** represent intermediate stages in terms of torque and maximum speed.

In ride modes **3** and **6**, an additional recuperation function (p. 26) is available.

Ride modes **1** to **3** are indicated by the illuminated single digit.

When ride modes **4**, **5**, and **6** are activated, the activated ride mode is displayed as the sum of the illuminated digits.

i Info

When the magnetic switch under the seat (p. 17) is not mounted, the ride mode cannot be changed.

The ride modes are switched through in ascending order; after ride mode **6**, the ride mode jumps back to **1**.

7.4 Malfunction indicator lamp

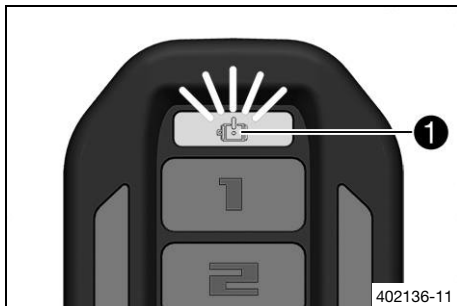

The warning tones emitted by the multifunctional element are synchronized with the flashing rhythm of malfunction indicator lamp **1**.

Possible states

	The malfunction indicator lamp flashes – A fault is present in the vehicle electronic system.
	The malfunction indicator lamp lights up – The system is carrying out a self-check or has been disabled during driving.

7.5 Charging level indicator

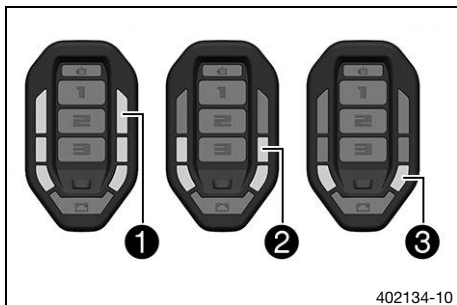

All segments **1** light up: charging level 70% - 100%.

Four segments **2** light up: charging level 50% - 70%.

Two segments **3** light up: charging level 30% - 50%.

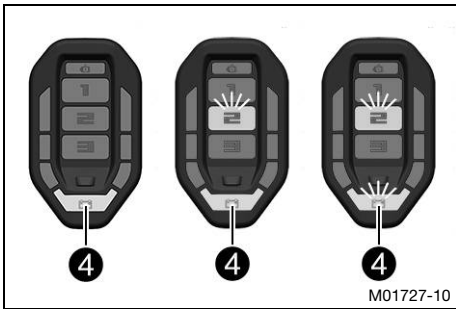

The last segment ④ lights up in yellow: charging level 20% - 30%.

The last segment ④ lights up in red and the driving mode indicator flashes red: charging level 10%–20%.

The last segment ④ and the driving mode indicator light up in red: charging level 0%–10%.

7.6 Power reduction

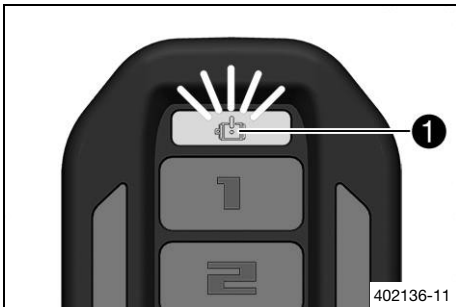

If the charging level (📖 p. 20) of the Powerpack LV is too low or the system temperature is outside of the permissible range, the power is automatically reduced.

The selected ride mode and the malfunction indicator lamp flash when the power has been reduced.

i Info

The blink code of malfunction indicator lamp ① can be used to determine the reason for the power reduction (see Troubleshooting chapter).

8.1 Advice on preparing for first use



Warning

Danger of accidents A lack of physical and mental readiness on the part of the child poses a major risk.

Children often underestimate or fail to recognize dangerous situations.

- Your child must already be able to ride a bicycle.
- Your child must be able to put the vehicle upright independently after a fall.
- Your child must understand that regulations and instructions from you or from other guardians must be followed.
- Make it clear to your child that he or she should not, under any circumstances, operate the vehicle without supervision.
- Make sure that the ride mode is appropriate for your child's riding ability and for the riding conditions.
If necessary, block the ride mode by removing the magnetic switch under the seat.
- Do not ask too much of your child.
Do not consider participation in competitive activities until your child's stamina, riding techniques and motivation are at the necessary levels.
- Only let your child ride on the vehicle if he or she is physically and mentally ready.



Warning

Risk of injury Missing or poor protective clothing presents an increased safety risk.

- Ensure your child wears appropriate protective clothing such as helmet, boots, gloves as well as trousers and a jacket with protectors on all rides.
- Always use protective clothing for your child that is in good condition and meets the legal requirements.
- When you ride a motorcycle, set an example for your child and wear suitable protective clothing.



Warning

Danger of crashing Different tire tread patterns on the front and rear wheel impair the handling characteristic.

Different tire tread patterns can make the vehicle significantly more difficult to control.

- Make sure that only tires with a similar tire tread pattern are fitted to the front and rear wheel.



Warning

Danger of accidents The vehicle is not designed to carry passengers.

- Make it clear to your child that he or she must not carry a passenger.



Warning

Danger of accidents The brake system fails in the event of overheating.

If the foot brake lever is not released, the brake linings drag continuously.

- Ensure that your child raises his or her foot from the foot brake lever if he or she does not want to brake.



Warning

Danger of accidents The suspension components will become damaged or destroyed if overloaded.

- Do not exceed the maximum permissible weight of the rider.



Warning

Risk of misappropriation People who act without authorization endanger themselves and others.

- Never leave the vehicle unattended.
- Protect the vehicle against access by unauthorized persons.

- Ensure that the pre-sale inspection work has been carried out by an authorized Husqvarna Motorcycles workshop.
- ✓ You will receive a delivery certificate when the vehicle is handed over.
- Read through the entire Owner's Manual together with your child before riding for the first time.



Info

Pay special attention to the safety instructions and to the risk of injury. Explain to your child the techniques of riding and falling, e.g., how shifting weight can influence handling characteristics.

- Familiarize your child with the controls.
- Adjust the basic position of the hand brake lever. (📖 p. 62)
- Adjust the basic position of the foot brake lever. 🦶 (📖 p. 70)
- Before using the vehicle for the first time, ensure that the basic settings of the chassis are suitable for the weight of your child.
- Allow your child to become accustomed to the handling of the motorcycle on suitable terrain, preferably on a large, open meadow.



Info

To give your child a feeling for the brake system, start by pushing your child. Do not start the motor until your child is able to apply the necessary front brake pressure. Your child should begin by riding to another person, who can help your child stop and turn.

- Erect obstacles for your child to navigate around so that your child becomes accustomed to handling the vehicle.
- Your child should also try to ride as slowly as possible and in a standing position to get a better feeling for the motorcycle.
- Your child should not ride on terrain that exceeds your child's capabilities and experience.
- Your child should hold the handlebar firmly with both hands and keep his or her feet on the footrests when riding.
- Make sure the maximum permissible weight of the rider is not exceeded.

Guideline

Maximum rider weight	45 kg (99 lb.)
Maximum rider size	< 130 cm (< 51.2 in)

- Check the spoke tension. (📖 p. 80)



Info

The spoke tension must be checked after half an hour of operation.



9.1 Checks and maintenance measures when preparing for use

i Info

Before every trip, check the condition of the vehicle and ensure that it is safe to operate. The vehicle must be in perfect technical condition when it is being operated.

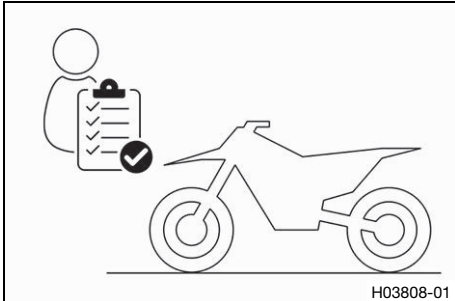

- Check the throttle grip, both magnetic switches, Powerpack LV, multifunctional element, and electric motor for external damage.
- Check the front brake fluid level. (📖 p. 64)
- Check the rear brake fluid level. (📖 p. 71)
- Check the front brake linings. (📖 p. 66)
- Check the brake linings of the rear brake. (📖 p. 72)
- Check that the brake system is functioning properly.
- Check the chain for dirt. (📖 p. 56)
- Check the chain, rear sprocket, motor sprocket, and chain guide. (📖 p. 58)
- Check the chain tension. (📖 p. 57)
- Check the tire condition. (📖 p. 79)
- Check tire pressure. (📖 p. 80)
- Check the spoke tension. (📖 p. 80)

i Info

The spoke tension must be checked regularly as incorrect spoke tension will strongly impair riding safety.

- Clean the dust boots of the fork legs. (📖 p. 46)
- Bleed the fork legs. (📖 p. 45)
- Check the settings of all controls and ensure that they can be operated smoothly.
- Check the tightness of the easily accessible, safety-relevant screws and nuts.
- Check the charging level of the Powerpack LV.

9.2 Starting the vehicle

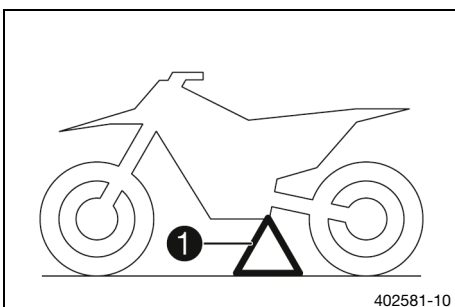

- Remove plug-in stand **1**.
- Press and hold the On/Off button until the multifunctional element lights up.
- ✓ The vehicle is in standby mode.

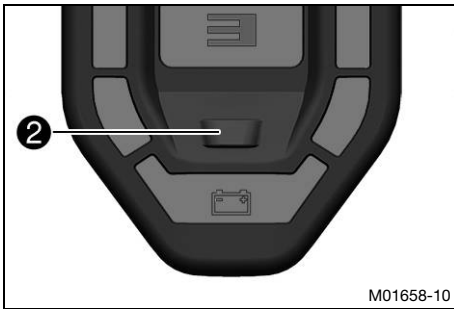

Optional:

- Press ride mode button ② to change the ride mode.

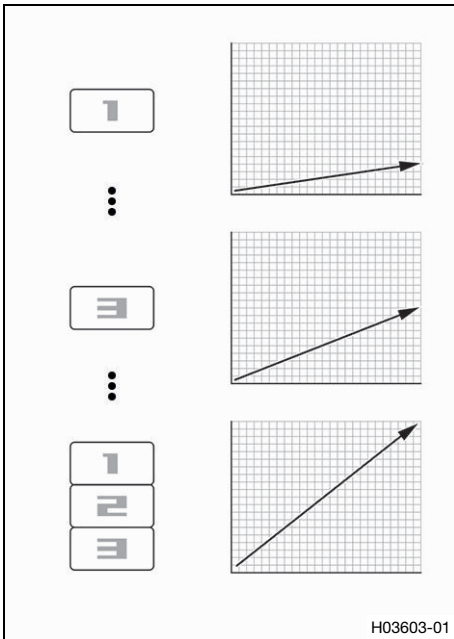

- Select one of the ride modes (📖 p. 20).
- Close the throttle grip beyond the basic position.
 - ✓ The vehicle emits a beep, is ready to ride, and reacts to the throttle grip.

9.3 Starting off

i Info
The plug-in stand must be removed before riding.

- Open the throttle carefully.

9.4 Applying the brakes

⚠ Warning
Danger of accidents Excessively forceful application of the brakes blocks the wheels.

- Explain to your child that he or she must adapt the braking to the traffic situation and the road conditions.

⚠ Warning
Danger of accidents A spongy pressure point on the front or rear brake reduces braking efficiency.

- Check the brake system and do not allow your child to continue riding until the problem is eliminated. (Your authorized Husqvarna Motorcycles workshop will be glad to help.)



Warning

Danger of accidents Moisture and dirt impair the brake system.

- Explain to your child that he or she must brake carefully several times to dry out and remove dirt from the brake linings and the brake discs.

- On sandy, wet, or slippery surfaces, use the rear brake.
- Always finish braking before you go into a bend.

9.5 Recuperation

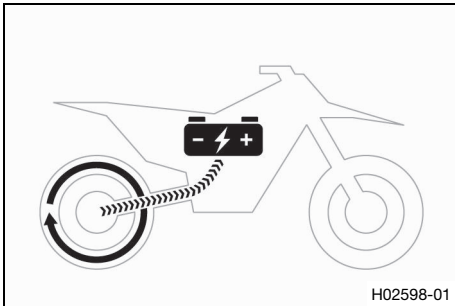

The Powerpack LV is charged by the electric motor in ride mode 3 and 6 (📖 p. 20) when the throttle grip is closed beyond the basic position in overrun.

The recuperation function results in an increased motor braking effect.

The recuperation effect is stronger in ride mode 6 than in ride mode 3.



Info

The recuperation function is not available in the remaining ride modes.

9.6 Stop, park



Warning

Risk of misappropriation People who act without authorization endanger themselves and others.

- Never leave the vehicle unattended.
- Protect the vehicle against access by unauthorized persons.



Warning

Danger of burns Some vehicle components become very hot when the vehicle is operated.

- Do not touch any parts such as the motor, lithium-ion battery, damper, or brake system before these vehicle parts have cooled down.
- Let the vehicle parts cool down before you perform any work on the vehicle.

Note

Material damage The vehicle may be damaged by incorrect procedure when parking.

Significant damage may be caused if the vehicle rolls away or falls over.

The components for parking the vehicle are designed only for the weight of the vehicle.

- Park the vehicle on a firm and level surface.
 - Ensure that nobody sits on the vehicle when the vehicle is parked on a stand.
-
- Apply the brakes on the motorcycle.
 - Press and hold the On/Off button until the multifunctional element goes out.
 - Remove the magnetic switch ☒ from the holder on the handlebar.
 - Park the motorcycle on firm ground.

9.7 Transporting

Note

Danger of damage The parked vehicle can roll away or fall over.

- Park the vehicle on a firm and level surface.

Note

Fire hazard Hot vehicle components pose a fire hazard and explosion risk.

- Do not park the vehicle near to materials which are highly flammable or explosive.
- Allow the vehicle to cool down before covering it.

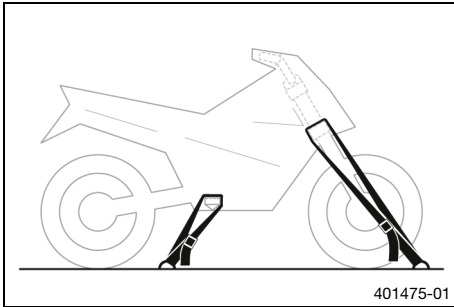

- Press and hold the On/Off button until the multifunctional element goes out.
- Remove the magnetic switch  from the holder on the handlebar.
- Use tension belts or other suitable devices to secure the motorcycle against falling over or rolling away.

10.1 Additional information

Any further work that results from the compulsory work or from the recommended work must be ordered separately and invoiced separately.

Different service intervals may apply in your country, depending on the local operating conditions.















Individual service intervals and scopes may change in the course of technical developments. The most up-to-date service schedule can always be found on Husqvarna Motorcycles Dealer.net. Your authorized Husqvarna Motorcycles dealer will be glad to advise you.

Always bring the battery charger with you when having the vehicle serviced.

The use of a service hour counter is recommended in order to be able to check the mileage at any time.

Service hour counter (45412920000)

10.2 Required work

	Every 80 operating hours	Every 40 operating hours	Every 20 operating hours	After 10 operating hours
Check the battery charger plug for damage and dirt. 	○	●	●	●
Read out the fault memory using the Husqvarna Motorcycles diagnostics tool.	○	●	●	●
Check that the electrical system is functioning properly. 	○	●	●	●
Check and charge the Powerpack LV. 	○	●	●	●
Check the front brake linings. (📖 p. 66)	○	●	●	●
Check the brake linings of the rear brake. (📖 p. 72)	○	●	●	●
Check the brake discs. (📖 p. 63)	○	●	●	●
Check the brake lines for damage and leakage.	○	●	●	●
Change the foot brake cylinder sealing cup. 		●	●	●
Check the rear brake fluid level. (📖 p. 71)	○	●	●	●
Check the free travel of the foot brake lever. (📖 p. 69)	○	●	●	●
Check the frame.  (📖 p. 60)		●	●	●
Check the link fork.  (📖 p. 61)		●	●	●
Check the fork bearing for play. 		●	●	●
Check the heim joint for play. 		●	●	●
Check the tire condition. (📖 p. 79)	○	●	●	●
Check tire pressure. (📖 p. 80)	○	●	●	●
Check the wheel bearing for play. 		●	●	●
Check the wheel hubs. 		●	●	●
Check the rim run-out. 	○	●	●	●
Check the spoke tension. (📖 p. 80)	○	●	●	●
Check the chain, rear sprocket, motor sprocket, and chain guide. (📖 p. 58)	○	●	●	●
Check the chain tension. (📖 p. 57)	○	●	●	●
Grease all moving parts (e.g., hand lever, chain, ...) and check for smooth operation. 	○	●	●	●
Check the front brake fluid level. (📖 p. 64)	○	●	●	●
Check the play of the handbrake lever. (📖 p. 62)	○	●	●	●
Check the steering head bearing play. (📖 p. 51)	○	●	●	●
Check cables and wires for damage and kink-free installation. 	○	●	●	●
Service the fork. 			●	●
Perform the shock absorber service. 				●

	Every 80 operating hours			
	Every 40 operating hours			
	Every 20 operating hours			
	After 10 operating hours			
Check the tightness of the easily accessible, safety-relevant screws and nuts. 🛠️	○	●	●	●
Final check: Check the vehicle for safe operation and take a test ride. 🛠️	○	●	●	●
Read out the fault memory after the test ride using the Husqvarna Motorcycles diagnostics tool.	○	●	●	●
Make a service entry in Husqvarna Motorcycles-Dealer.net . 🛠️	○	●	●	●

- One-time interval
- Periodic interval

10.3 Recommended work

	Every 40 operating hours			
	After 20 operating hours / Every 20 operating hours			
	After 10 operating hours			
	every 12 months			
Change the front brake fluid. 🛠️	●			
Change the rear brake fluid. 🛠️	●			
Service the fork. 🛠️		○		
Perform the shock absorber service. 🛠️			○	
Lubricate the steering head bearing. 🛠️ (📖 p. 52)	●			
Check the pinion shaft bearings, O-rings and the bearing seals. 🛠️			●	
Change the pinion shaft bearings, the O-rings and the bearing seals. 🛠️				●

- One-time interval
- Periodic interval

11.1 Checking the basic chassis setting with the rider's weight

i Info

When adjusting the basic chassis setting, first adjust the shock absorber and then the fork.

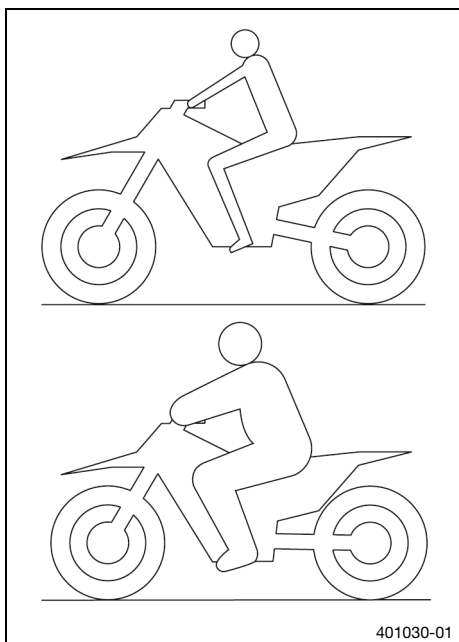

- For optimal motorcycle riding characteristics and to avoid damage to forks, shock absorbers, link fork and frame, the basic settings of the suspension components must match the rider's weight.
- This vehicle is delivered pre-set for a standard rider's weight (with full protective clothing).

Guideline

Standard rider weight	25 ... 35 kg (55 ... 77 lb.)
-----------------------	------------------------------

- If the rider's weight is above or below this range, the basic setting of the suspension components must be adjusted accordingly.
- Small weight differences can be compensated by adjusting the spring preload and the fork air pressure, but in the case of larger weight differences, the springs must be replaced.

11.2 Air suspension XACT 5235

Air suspension **WP Suspension XACT 5235** is used in the fork.

In this system, suspension is located in the left fork leg and damping in the right fork leg.

A significant weight advantage is achieved compared with conventional forks. The response on slightly uneven surfaces is significantly improved.

In normal driving mode, suspension is provided exclusively by an air cushion. A steel spring is located in the left fork leg as an end stop.

i Info

If the fork is frequently overloaded, then the air pressure in the fork must be increased to avoid damage to the fork and frame.

The air pressure in the fork can be quickly adjusted to the rider's weight, surface conditions and the rider's preference using a fork airpump. The fork does not have to be dismantled. The time consuming mounting of harder or softer fork springs is not required.

If the air chamber loses air due to a damaged seal, the fork will still not sag. In this case the air is retained in the fork. The suspension travel is maintained as far as possible. The damping becomes harder and the riding comfort reduces.

The rebound damping can be adjusted.

The rebound adjustment is located at the upper end of the right fork leg.

11.3 Compression damping of the shock absorber

The compression damping of the shock absorber is divided into two ranges: high-speed and low-speed. High-speed and low-speed refer to the compression speed of the rear wheel suspension and not to the vehicle speed.

The high-speed compression adjuster has an effect, for example, when landing after a jump: the rear wheel suspension compresses quickly.

The low-speed compression adjuster has an effect, for example, when riding over long ground swells: the rear wheel suspension compresses slowly.

These two ranges can be adjusted separately, although the transition between high-speed and low-speed is gradual. Thus, modifications in the high-speed range affect the compression damping in the low-speed range and vice versa.

11.4 Adjusting the low-speed compression damping of the shock absorber



Caution

Risk of injury Parts of the shock absorber will move around if the shock absorber is detached incorrectly.

The shock absorber is filled with highly compressed nitrogen.

- Please follow the description provided. (Your authorized Husqvarna Motorcycles workshop will be glad to help.)



Info

The effect of the low-speed compression adjuster can be seen in slow to normal compression of the shock absorber.

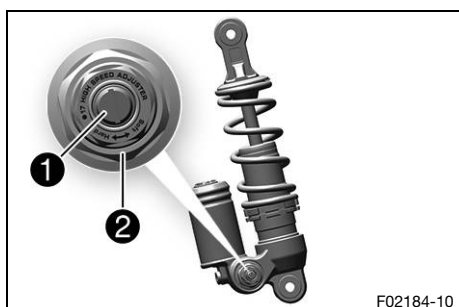

- Turn adjusting screw ① clockwise with a screwdriver as far as the last perceptible click.



Info

Do not loosen fitting ②!

- Turn counterclockwise by the number of clicks corresponding to the shock absorber type.

Guideline

Low-speed compression damping	
Comfort	18 clicks
Standard	15 clicks
Sport	12 clicks



Info

Turn clockwise to increase damping; turn counterclockwise to reduce damping.

11.5 Adjusting the high-speed compression damping of the shock absorber



Caution

Risk of injury Parts of the shock absorber will move around if the shock absorber is detached incorrectly.

The shock absorber is filled with highly compressed nitrogen.

- Please follow the description provided. (Your authorized Husqvarna Motorcycles workshop will be glad to help.)



Info

The effect of the high-speed compression adjuster can be seen in fast compression of the shock absorber.

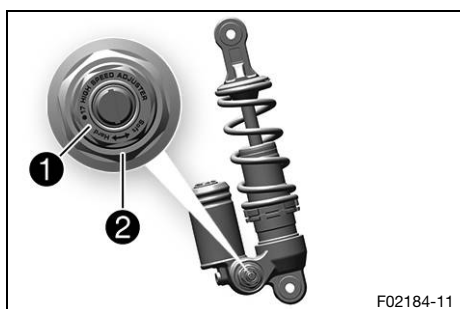

- Push the splash protector to the side.
- Using an open end wrench, turn adjusting screw ① clockwise all the way.



Info

Do not loosen fitting ②!

- Turn counterclockwise by the number of turns corresponding to the shock absorber type.

Guideline

High-speed compression damping	
Comfort	2.5 turns
Standard	2 turns
Sport	1.5 turns



Info

Turn clockwise to increase damping; turn counterclockwise to reduce damping.

- Position the splash protector.

11.6 Adjusting the rebound damping of the shock absorber



Caution

Risk of injury Parts of the shock absorber will move around if the shock absorber is detached incorrectly.

The shock absorber is filled with highly compressed nitrogen.

- Please follow the description provided. (Your authorized Husqvarna Motorcycles workshop will be glad to help.)

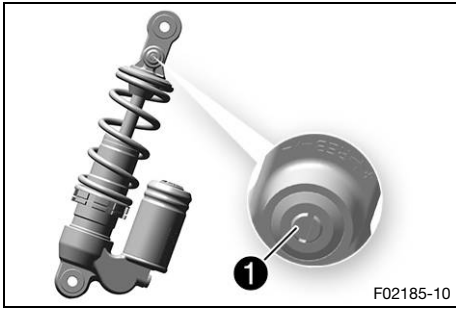

- Turn adjusting screw ① clockwise up to the last perceptible click.
- Turn counterclockwise by the number of clicks corresponding to the shock absorber type.

Guideline

Rebound damping	
Comfort	17 clicks
Standard	15 clicks
Sport	13 clicks

i Info
Turn clockwise to increase the damping; turn counterclockwise to reduce damping when the shock absorber rebounds.



11.7 Measuring the dimension of the rear wheel unloaded

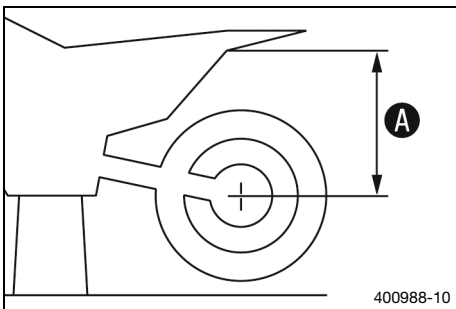

Preparatory work

- Raise the motorcycle with a lift stand. (📖 p. 45)

Main work

- Measure the vertical distance between the rear axle and a fixed point, such as a marking on the side cover.
- Note the value as dimension ①.

Finishing work

- Remove the motorcycle from the lift stand. (📖 p. 45)



11.8 Checking the static sag of the shock absorber

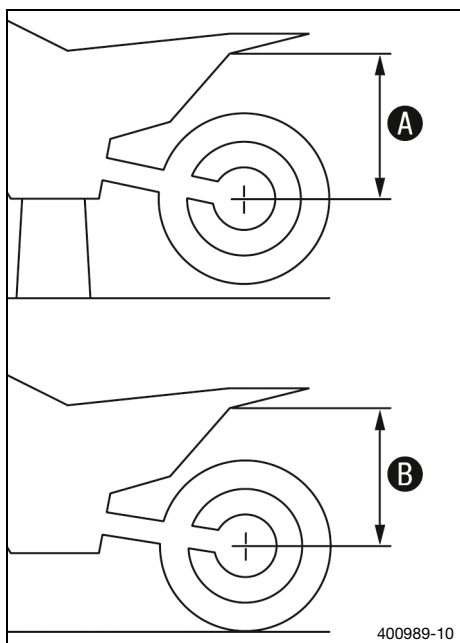

- Measure dimension **A** of rear wheel unloaded. (📖 p. 33)
- Hold the motorcycle upright with aid of an assistant.
- Measure the distance between rear axle and fixed point again.
- Note the value as dimension **B**.

i Info
The static sag is the difference between measurements **A** and **B**.

- Check the static sag.

Static sag	12 mm (0.47 in)
------------	-----------------

- » If the static sag is less or more than the specified value:
 - Adjust the spring preload of the shock absorber. (🔧 p. 35)

11.9 Checking the riding sag of the shock absorber

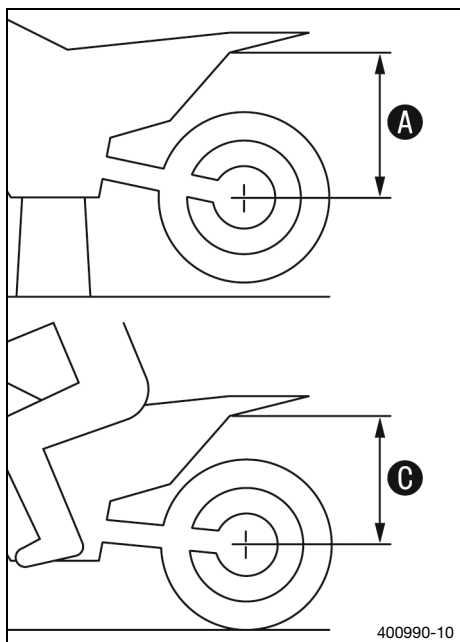

- Measure dimension **A** of rear wheel unloaded. (📖 p. 33)
- With another person holding the motorcycle, the rider, wearing full protective clothing, sits on the seat in a normal sitting position (feet on footrests) and bounces up and down a few times.
- ✓ The rear wheel suspension levels out.
- Another person now measures the distance between the rear axle and the fixed point.
- Note the value as dimension **C**.

i Info
The riding sag is the difference between measurements **A** and **C**.

- Check riding sag.

Riding sag	80 mm (3.15 in)
------------	-----------------

- » If the riding sag differs from the specified measurement:
 - Adjust the riding sag. (🔧 p. 36)

11.10 Adjusting the spring preload of the shock absorber ↩



Caution

Risk of injury Parts of the shock absorber will move around if the shock absorber is detached incorrectly.

The shock absorber is filled with highly compressed nitrogen.

- Please follow the description provided. (Your authorized Husqvarna Motorcycles workshop will be glad to help.)

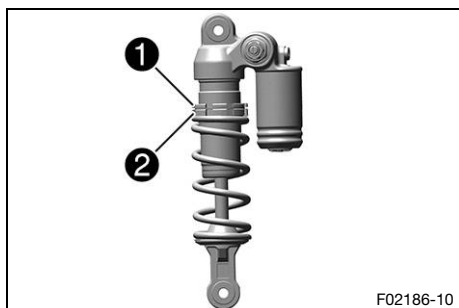

Preparatory work

- Raise the motorcycle with a lift stand. (📖 p. 45)
- Remove the shock absorber. (🔧 p. 54)
- After removing the shock absorber, clean it thoroughly.

Main work

- Measure the full spring length while it is under tension and note down the value.
- Loosen retaining ring ❶.
- Turn adjusting ring ❷ until the spring is no longer under tension.

Hook wrench (T304)

Hook wrench (T1533)

- Measure the total spring length while the spring is not under tension.
- Tighten the spring to the specified measurement by turning adjusting ring ❷.

Guideline

Spring preload	3 mm (0.12 in)
----------------	----------------



Info

The spring preload is the difference between the relaxed spring length and the tensioned spring length. Depending on the static sag and/or the riding sag, it may be necessary to increase or decrease the spring preload.

- Tighten retaining ring ❶.

Finishing work

- Install the shock absorber. (🔧 p. 54)
- Remove the motorcycle from the lift stand. (📖 p. 45)

11.11 Adjusting the riding sag 🛠️

Preparatory work

- Raise the motorcycle with a lift stand. (📖 p. 45)
- Remove the shock absorber. 🛠️ (📖 p. 54)
- After removing the shock absorber, clean it thoroughly.

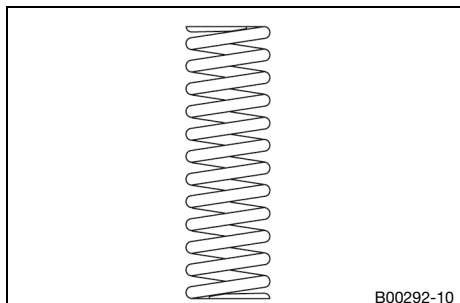

Main work

- Choose and mount a suitable spring.

Guideline

Spring rate	
Weight of rider: 15 ... 25 kg (33 ... 55 lb.)	25 N/mm (143 lb/in)
Weight of rider (standard): 25 ... 35 kg (55 ... 77 lb.)	30 N/mm (171 lb/in)
Weight of rider: 35 ... 45 kg (77 ... 99 lb.)	35 N/mm (200 lb/in)

i Info

The spring rate is shown on the outside of the spring. Smaller weight differences can be compensated by changing the spring preload.

Finishing work

- Install the shock absorber. 🛠️ (📖 p. 54)
- Remove the motorcycle from the lift stand. (📖 p. 45)
- Check the static sag of the shock absorber. (📖 p. 34)
- Check the riding sag of the shock absorber. (📖 p. 34)
- Adjust the rebound damping of the shock absorber. (📖 p. 32)

11.12 Checking the basic setting of the fork

i Info

For various reasons, no exact riding sag can be determined for the fork.

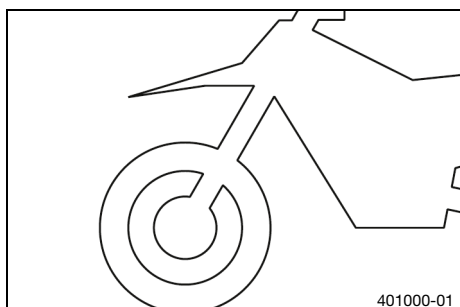

- Smaller differences in the rider's weight can be compensated for by the fork air pressure.
- However, if the fork frequently bottoms out (hard end stop on compression), the fork air pressure must be increased, within the specified values, to avoid damage to the fork and frame.

11.13 Adjusting the fork air pressure



Warning

Danger of accidents Modifications to the suspension setting may seriously alter the handling characteristic.

Extreme modifications to the suspension setting may cause a serious deterioration in the handling characteristic and overload components.

- Only make adjustments within the recommended range.
- Make sure your child rides slowly to start with after making adjustments in order that he or she can assess the new handling characteristic.



Info

Check or adjust the air pressure 5 minutes, at the earliest, after the end of the ride and under the same conditions.

The air suspension is located in the left fork leg. The rebound damping is located in the right fork leg.

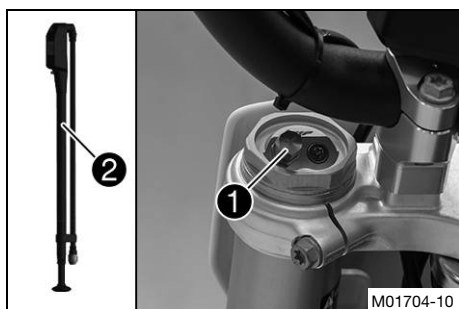

Preparatory work

- Raise the motorcycle with a lift stand. (📖 p. 45)

Main work

- Remove protection cap ①.
- Push together fork airpump ② fully.

Fork airpump (79412966100)



Info

The fork airpump is included as part of the motorcycle's accessory pack.

- Connect the fork airpump to the left fork leg.
 - ✓ The fork airpump indicator switches on automatically.
 - ✓ A little air escapes from the fork leg when connecting.



Info

This is due to the volume of the hose and not due to a defect in the fork airpump or the fork. Read the accompanying instructions for Husqvarna Motorcycles accessories.

- Adjust the air pressure as specified.

Guideline

Air pressure	2 bar (29 psi)
Gradual changing of the air pressure in steps of	0.2 bar (3 psi)
Minimum air pressure	1.4 bar (20 psi)
Maximum air pressure	4 bar (58 psi)



Info

Never adjust the air pressure to a value outside the stated range.

- Disconnect the fork airpump from the left fork leg.

11 SUSPENSION SETTING

- ✓ When disconnecting, excess pressure will escape from the hose – the fork leg itself does not lose any air.
- ✓ The fork airpump indicator switches off automatically after 80 seconds.
- Mount the protection cap.



Info

Only mount the protection cap by hand.

Finishing work

- Remove the motorcycle from the lift stand. (📖 p. 45)

11.14 Adjusting the rebound damping of the fork



Info

The hydraulic rebound damping determines the fork suspension behavior.



- Turn adjuster ① clockwise all the way.



Info

Adjuster ① is located at the upper end of the right fork leg.

- Turn counterclockwise by the number of clicks corresponding to the fork type.

Guideline

Rebound damping	
Comfort	15 clicks
Standard	12 clicks
Sport	10 clicks



Info

Turn clockwise to increase the damping; turn counterclockwise to reduce damping when the shock absorber rebounds.

11.15 Handlebar position

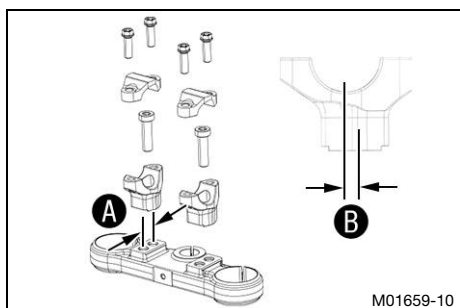

On the upper triple clamp, there are 2 holes at a distance of ① to each other.

Hole distance ①	15 mm (0.59 in)
-----------------	-----------------

The holes on the handlebar support are placed at a distance of ② from the center.

Hole distance ②	3.5 mm (0.138 in)
-----------------	-------------------

The handlebar holder can be mounted in four different positions. This allows the handlebar to be mounted in the most comfortable position for the rider.

11.16 Adjusting the handlebar position ↩



Warning

Danger of accidents A repaired handlebar poses a safety risk.

If the handlebar is bent or straightened, the material becomes fatigued. The handlebar may break as a result.

- Change the handlebar if the handlebar is damaged or bent.

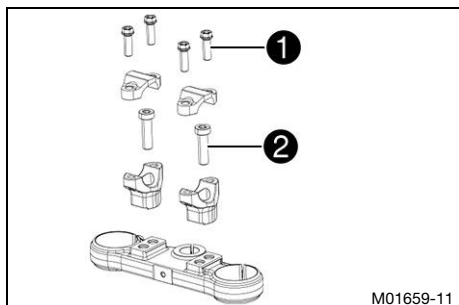

M01659-11

- Remove screws **1**. Take off the handlebar clamps. Remove the handlebar and lay it to one side.



Info

Cover the components to protect them against damage.
Do not kink the cables and lines.

- Remove screws **2**. Take off handlebar supports.
- Place handlebar supports in required position. Mount and tighten screws **2**.

Guideline

Screw, handlebar support	M10	40 Nm (29.5 lbf ft) Loctite®243™
--------------------------	-----	--

Mount the left and right handlebar supports in the same position.

- Position the handlebar.



Info

Make sure the cables and wiring are positioned correctly.

- Position the handlebar clamps. Mount screws **1** and tighten evenly.

Guideline

Screw, handlebar clamp	M8	20 Nm (14.8 lbf ft)
------------------------	----	---------------------



Info

Make sure the installed gaps are even.

12.1 Seat height adjustment options

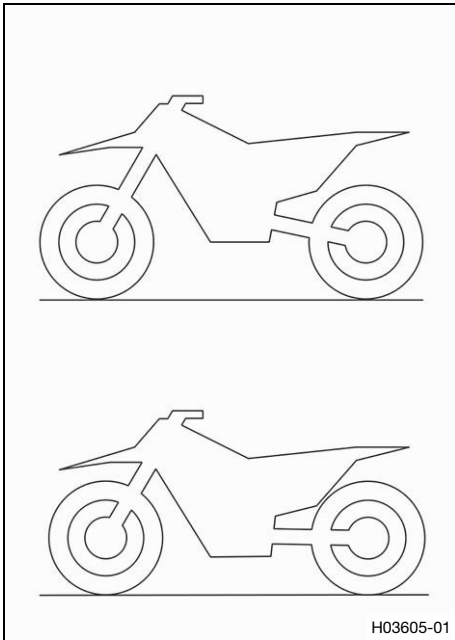

This vehicle offers several options for adjusting the seat height to the rider's height.

The seat height can be changed with the mounting position of the fork, shock absorber, and frame.

i Info

When adjusting the seat height on the fork and shock absorber, make sure that the vehicle is as straight as possible after completion of the work.

If the seat height on the shock absorber is set low, the fork should be pushed through further and vice versa.

12.2 Adjusting the seat height on the shock absorber ↻



Warning

Danger of accidents Modifications to the suspension setting may seriously alter the handling characteristic.

- Make sure your child rides slowly to start with after making adjustments in order that he or she can assess the new handling characteristic.



Info

If the seat height is adjusted on the shock absorber, the seat height should also be adjusted on the fork.



Preparatory work

- Raise the motorcycle with a lift stand. (📖 p. 45)

Main work

- Hold the rear wheel with the link fork and remove screw ①.
- Position the shock absorber according to the required seat height.

Guideline

High seat position	A
Low seat position	B

- Mount and tighten screw ①.

Guideline

Screw, top shock absorber	M10	45 Nm (33.2 lbf ft) Loctite®243™
---------------------------	-----	--

Finishing work

- Remove the motorcycle from the lift stand. (📖 p. 45)

12.3 Adjusting the seat height on the fork



Warning

Danger of accidents Modifications to the suspension setting may seriously alter the handling characteristic.

- Make sure your child rides slowly to start with after making adjustments in order that he or she can assess the new handling characteristic.



Info

The seat height can be infinitely adjusted by pushing the fork legs through.
If the seat height is adjusted on the fork, the seat height should also be adjusted on the shock absorber.

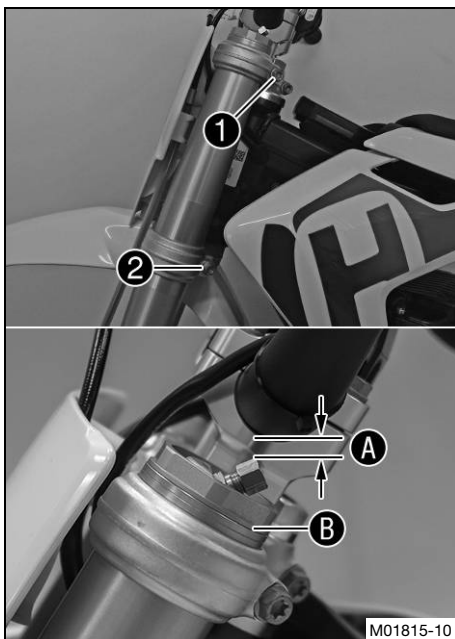

Preparatory work

- Raise the motorcycle with a lift stand. (📖 p. 45)
- Remove the front wheel. 🗨️ (📖 p. 76)

Main work

- Loosen screw ①.
- Loosen screw ②.
- Position the fork leg according to the required seat height.

Guideline

Condition

Seat position as low as possible, fork fully inserted

Minimum distance A between the fork and handlebar	3 mm (0.12 in)
---	----------------

Condition

Seat position as high as possible, fork pulled out completely

Bottom edge of screw cap B closes flush with the upper edge of the triple clamp
--

Position the fork leg only within the described range.

- Tighten screw ②.

Guideline

Screw, bottom triple clamp	M8	15 Nm (11.1 lbf ft)
----------------------------	----	---------------------

- Tighten screw ①.

Guideline

Screw, top triple clamp	M8	20 Nm (14.8 lbf ft)
-------------------------	----	---------------------

- Repeat the procedure on the other fork leg.

Guideline

Position both fork legs equally.

Finishing work

- Install the front wheel. 🗨️ (📖 p. 76)

12.4 Adjusting the seat height on the frame

Preparatory work

- Remove the seat. (📖 p. 55)

Main work

- Remove screw ❶.

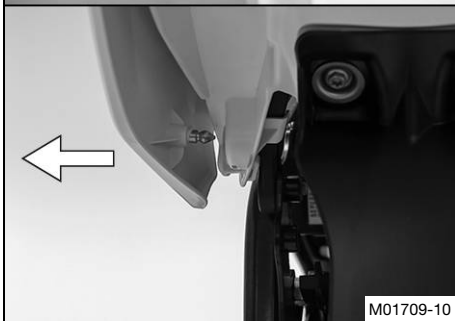
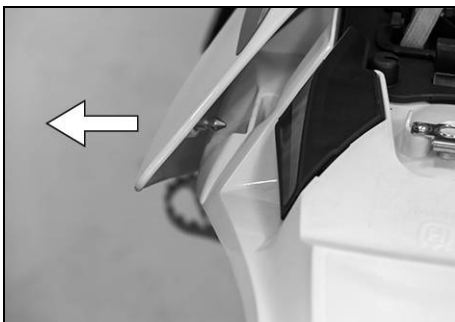

- Pull off the front fairing sideways on both sides and remove it upward.

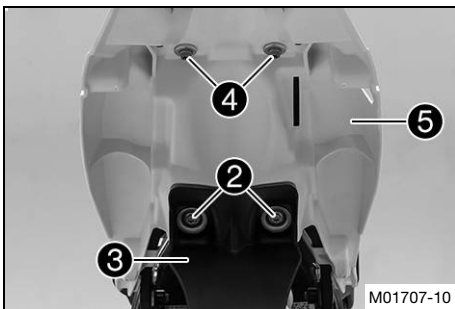

- Remove screws ❷ with bushings and splash protector ❸.
- Remove screws ❹ with bushings and rear fairing ❺.

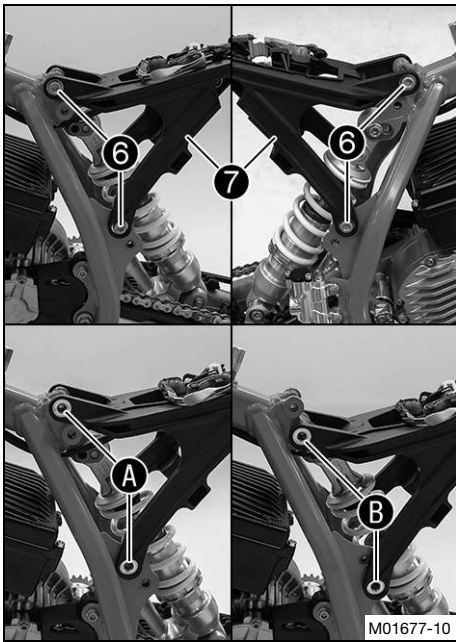

- Remove screws 6 and position subframe 7 at the drill holes at the desired seat height.

Guideline

Pay attention to the wiring harness.	
High seat position	Drill holes A
Low seat position	Drill holes B

- Mount and tighten screws 6.

Guideline

Screw, sub-frame	M8	30 Nm (22.1 lbf ft) Loctite®243™
------------------	----	--

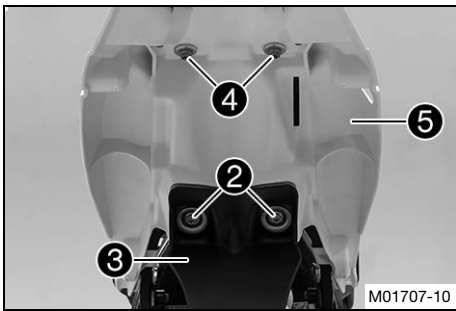

- Position rear fairing 5, mount screws 4 with bushings, and tighten.

Guideline

Rear fairing screw	M6	8 Nm (5.9 lbf ft)
--------------------	----	-------------------

- Position splash protector 3, mount screws 2 with bushings, and tighten.

Guideline

Screw, splash protector	M6	8 Nm (5.9 lbf ft)
-------------------------	----	-------------------

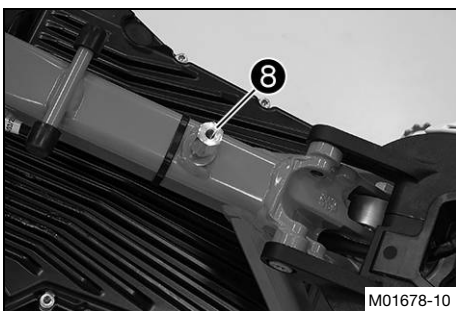

Condition

High seat position

- Make sure that thread adapter 8 is mounted and tightened.

Guideline

Threaded adapter for front fairing	M6	8 Nm (5.9 lbf ft)
------------------------------------	----	-------------------

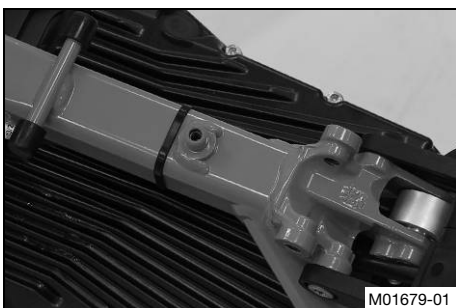

Condition

Low seat position

- Make sure that the thread adapter is removed.



Info

Retain the thread adapter for later assembly.

12 SEAT HEIGHT

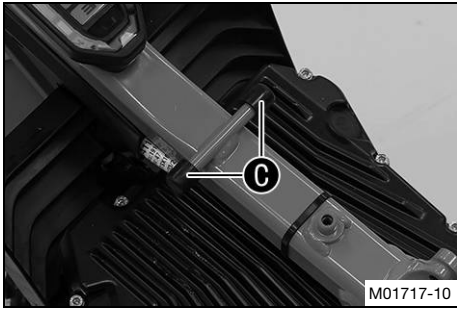

- Position the front fairing on holders **C**.

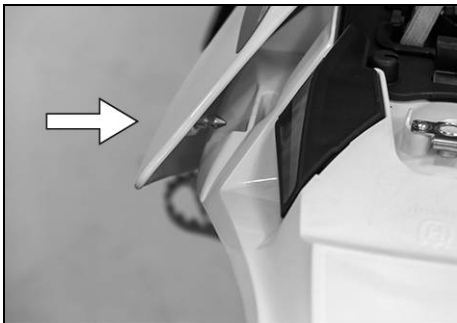

- Engage the front fairing on both sides.

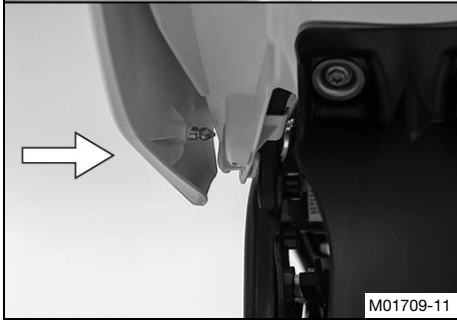

- Mount and tighten screw **1**.

Guideline

Remaining screws, chassis	M6	10 Nm (7.4 lbf ft)
------------------------------	----	--------------------

Finishing work

- Mount the seat. (📖 p. 55)

13.1 Raising the motorcycle with a lift stand

Note

Danger of damage The parked vehicle can roll away or fall over.

- Park the vehicle on a firm and level surface.

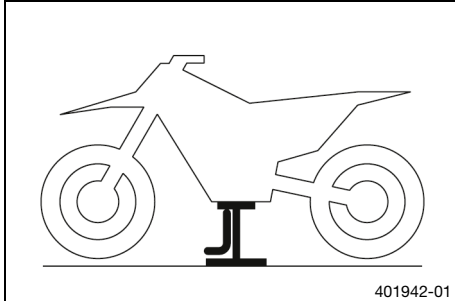

- Raise the motorcycle at the frame underneath the engine.

Lift stand (78929955100)

- ✓ Neither wheel is in contact with the ground.
- Secure the motorcycle against falling over.

13.2 Removing the motorcycle from the lift stand

Note

Danger of damage The parked vehicle can roll away or fall over.

- Park the vehicle on a firm and level surface.

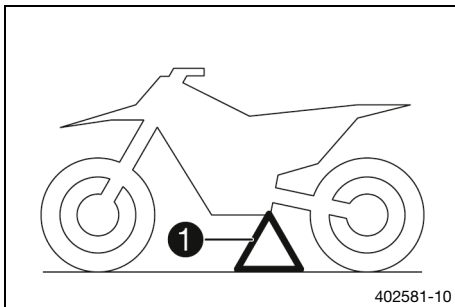

- Remove the motorcycle from the lift stand.
- Remove the lift stand.
- To park the motorcycle, insert plug-in stand ① into the plug-in stand bracket on the left side of the vehicle.



Info

Remove the plug-in stand before riding.

13.3 Bleeding the fork legs

Preparatory work

- Raise the motorcycle with a lift stand. (📖 p. 45)

Main work

- Release bleeder screws ①.
- ✓ Any excess pressure escapes from the interior of the fork.
- Tighten the bleeder screws.

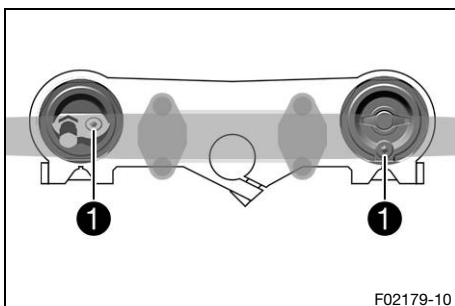

Finishing work

- Remove the motorcycle from the lift stand. (📖 p. 45)

13.4 Cleaning the dust boots of the fork legs

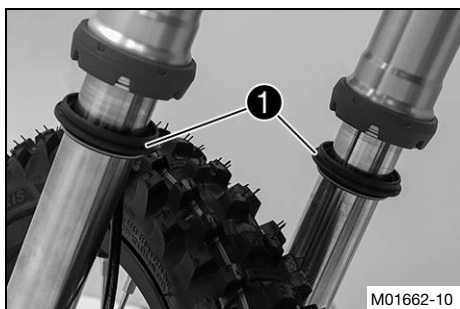

Preparatory work

- Raise the motorcycle with a lift stand. (📖 p. 45)
- Remove the fork protector. (📖 p. 46)

Main work

- Push dust boots ❶ of both fork legs downward.

Info

The dust boots remove dust and coarse dirt particles from the inside fork tubes. Over time, dirt can accumulate behind the dust boots. If this dirt is not removed, the seals rings behind can start to leak.

Warning

Danger of accidents Oil or grease on the brake discs reduces the braking effect.

- Always keep the brake discs free of oil and grease.
 - Clean the brake discs with brake cleaner when necessary.
- Clean and oil the dust boots and inner fork tubes of both fork legs.

Universal oil spray (📖 p. 99)

- Press the dust boots back into the installation position.
- Remove the excess oil.

Finishing work

- Install the fork protector. (📖 p. 47)
- Remove the motorcycle from the lift stand. (📖 p. 45)

13.5 Removing the fork protector

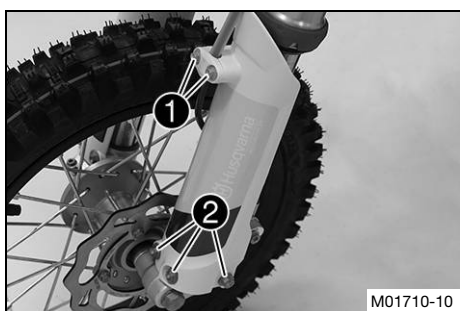

- Remove screws ❶ and take off the clamp.
- Remove screws ❷ on the left and right rear fork leg. Take off the fork protector.

13.6 Installing the fork protector

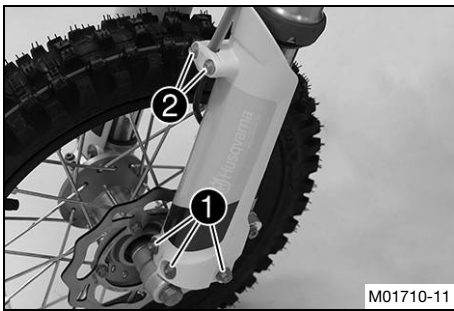

- Position the fork protector on the left and right fork leg. Mount and tighten screws **1**.

Guideline

Remaining screws, chassis	M6	10 Nm (7.4 lbf ft)
---------------------------	----	--------------------

- Position the brake line and the clamp. Mount and tighten screws **2**.

Guideline

Screw, brake line clamp on fork protector	EJOT PT® K60x20-AL	2 Nm (1.5 lbf ft)
---	-------------------------------------	-------------------



13.7 Removing the fork legs

Preparatory work

- Raise the motorcycle with a lift stand. (📖 p. 45)
- Remove the front wheel. 🗝️ (📖 p. 76)

Main work

- Remove screws **1** and take off the clamp.
- Remove screws **2** and take off the brake caliper.
- Allow the brake caliper and the brake line to hang loosely to the side.

i Info
Do not kink the brake line.

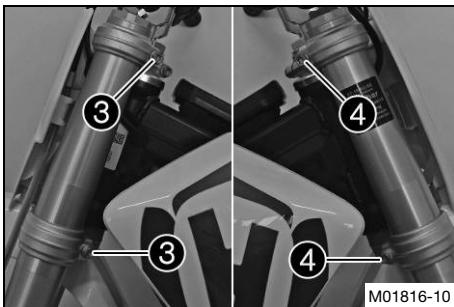
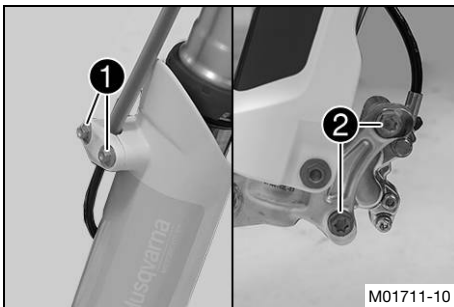

- Note the installation position of the fork legs.
- Loosen screws **3**. Remove the left fork leg.
- Loosen screws **4**. Remove the right fork leg.

13.8 Installing the fork legs

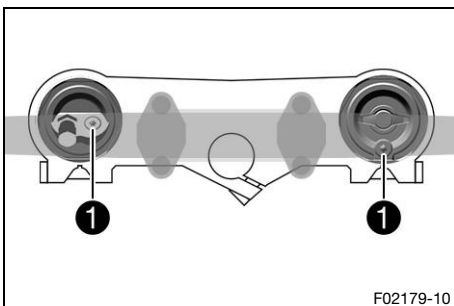

Condition

Individual installation position

- Position the fork legs.

Guideline

Observe the position determined during removal.

- ✓ Bleeder screws **1** are positioned toward the rear.

Condition

Standard installation position

- Position the fork legs.

13 SERVICE WORK ON THE CHASSIS

- ✓ Bleeder screws ❶ are positioned toward the rear.
- ✓ The second milled groove (from the top) is flush with the upper edge of the upper triple clamp.

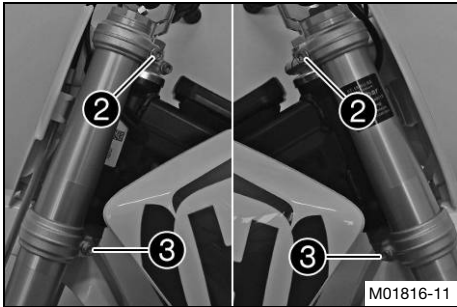

- Tighten screws ❷.

Guideline

Screw, top triple clamp	M8	20 Nm (14.8 lbf ft)
-------------------------	----	---------------------

- Tighten screws ❸.

Guideline

Screw, bottom triple clamp	M8	15 Nm (11.1 lbf ft)
----------------------------	----	---------------------

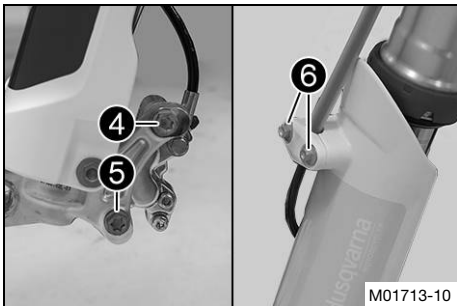

- Position the brake caliper, mount screw ❹, and tighten.

Guideline

Screw, front brake caliper	M8x60	20 Nm (14.8 lbf ft) Loctite®243™
----------------------------	-------	--

- Mount and tighten screw ❺.

Guideline

Screw, front brake caliper	M8x40	20 Nm (14.8 lbf ft) Loctite®243™
----------------------------	-------	--

- Position the brake line and the clamp. Mount and tighten screws ❻.

Guideline

Screw, brake line clamp on fork protector	EJOT PT® K60x20-AL	2 Nm (1.5 lbf ft)
---	-------------------------------	-------------------

Finishing work

- Install the front wheel. 🛠️ (📖 p. 76)

13.9 Removing the lower triple clamp 🛠️

Preparatory work

- Raise the motorcycle with a lift stand. (📖 p. 45)
- Remove the front wheel. 🛠️ (📖 p. 76)
- Remove the fork legs. 🛠️ (📖 p. 47)
- Remove the start number plate. (📖 p. 53)
- Remove front fender. (📖 p. 53)

Main work

- Remove nut ❶.
- Remove the cable tie on the magnetic switch cable from the handlebar.
- Release screw ❷, take off the upper triple clamp with the handlebar and set aside.

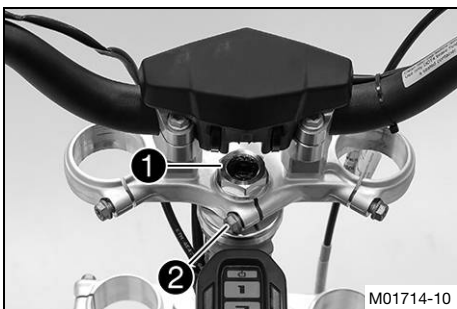



Info

Cover the components to protect them against damage.
Do not kink the cables and lines.

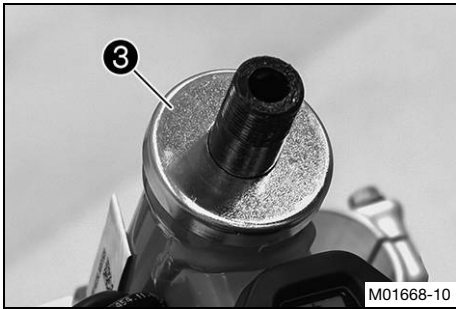

M01668-10

- Remove protective ring **3**.
- Remove the lower triple clamp with the steering stem.
- Remove the upper steering head bearing.

13.10 Installing the lower triple clamp

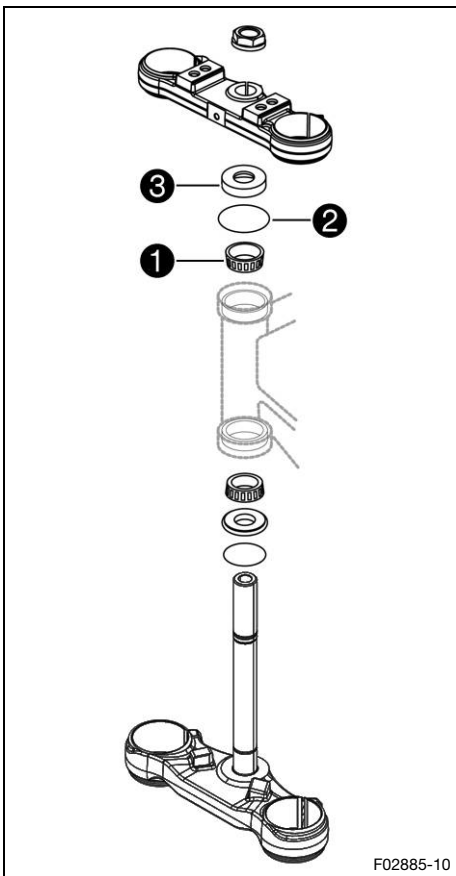

F02885-10

Main work

- Clean the bearing and sealing elements, check for damage, and grease.

High viscosity grease (📖 p. 99)

- Insert the lower triple clamp with the steering stem. Mount upper steering head bearing **1**.
- Check that the O-ring at the top **2** is correctly positioned.
- Push on protective ring **3**.

13 SERVICE WORK ON THE CHASSIS

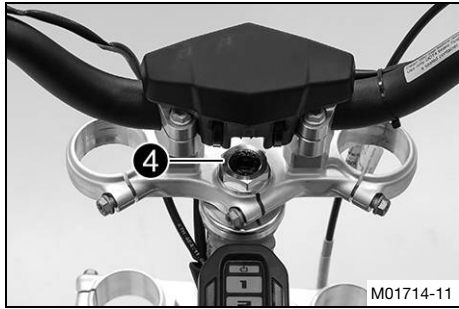

- Position the upper triple clamp with the handlebar.
- Mount nut **4**, but do not tighten it yet.

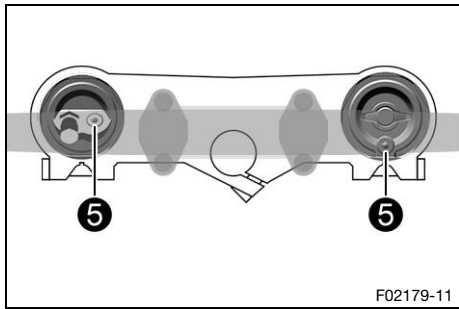

Condition

Individual installation position

- Position the fork legs.

Guideline

Observe the position determined during removal.

- ✓ Bleeder screws **5** are positioned toward the rear.

Condition

Standard installation position

- Position the fork legs.

- ✓ Bleeder screws **5** are positioned toward the rear.

- ✓ The second milled groove (from the top) is flush with the upper edge of the upper triple clamp.

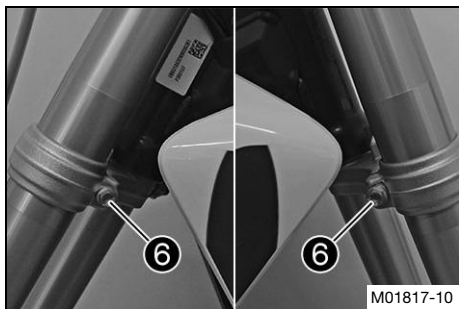

- Tighten screws **6**.

Guideline

Screw, bottom triple clamp	M8	15 Nm (11.1 lbf ft)
----------------------------	----	---------------------

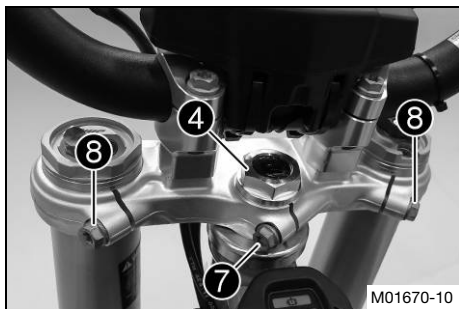

- Tighten nut **4**.

Guideline

Nut, steering head	M20x1.5	10 Nm (7.4 lbf ft)
--------------------	---------	--------------------

- Tighten screw **7**.

Guideline

Screw, top triple clamp	M8	20 Nm (14.8 lbf ft)
-------------------------	----	---------------------

- Using a plastic hammer, tap lightly on the upper triple clamp to avoid stresses.

- Tighten screws **8**.

Guideline

Screw, top triple clamp	M8	20 Nm (14.8 lbf ft)
-------------------------	----	---------------------

- Fix the magnetic switch cable to the handlebar with a new cable tie.

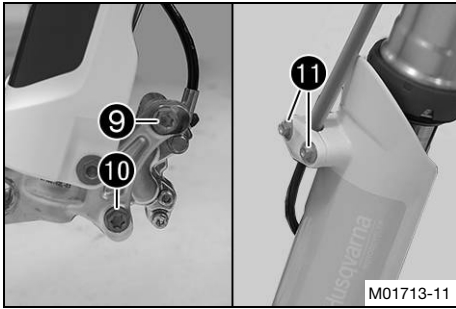

- Position the brake caliper, mount screw 9, and tighten.

Guideline

Screw, front brake caliper	M8x60	20 Nm (14.8 lbf ft) Loctite®243™
----------------------------	-------	--

- Mount and tighten screw 10.

Guideline

Screw, front brake caliper	M8x40	20 Nm (14.8 lbf ft) Loctite®243™
----------------------------	-------	--

- Position the brake line and the clamp. Mount and tighten screws 11.

Guideline

Screw, brake line clamp on fork protector	EJOT PT® K60x20-AL	2 Nm (1.5 lbf ft)
---	-------------------------------	-------------------

Finishing work

- Install front fender. (📖 p. 54)
- Install the start number plate. (📖 p. 53)
- Check that the cable and brake line are routed correctly.
- Install the front wheel. 🛠️ (📖 p. 76)
- Check the steering head bearing play. (📖 p. 51)
- Remove the motorcycle from the lift stand. (📖 p. 45)



13.11 Checking the steering head bearing play



Warning

Danger of accidents Incorrect steering head bearing play impairs the handling characteristic and damages components.

- Correct incorrect steering head bearing play immediately. (Your authorized Husqvarna Motorcycles workshop will be glad to help.)



Info

If the vehicle is operated for a lengthy period with play in the steering head bearing, the bearings and the bearing seats in the frame can become damaged over time.

Preparatory work

- Raise the motorcycle with a lift stand. (📖 p. 45)

Main work

- Move the handlebar to the straight-ahead position. Move the fork legs to and fro in the direction of travel.

Play should not be detectable on the steering head bearing.

- » If there is detectable play:
 - Adjust the steering head bearing play. 🛠️ (📖 p. 52)
- Move the handlebar to and fro over the entire steering range.

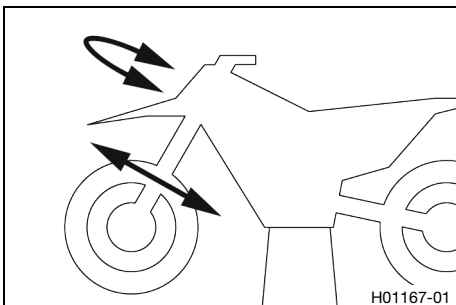

It must be possible to move the handlebar easily over the entire steering range. There should be no detectable detent positions.

- » If detent positions are detected:
 - Adjust the steering head bearing play. (📖 p. 52)
 - Check the steering head bearing and replace if required.

Finishing work

- Remove the motorcycle from the lift stand. (📖 p. 45)

13.12 Adjusting the steering head bearing play 🛠️

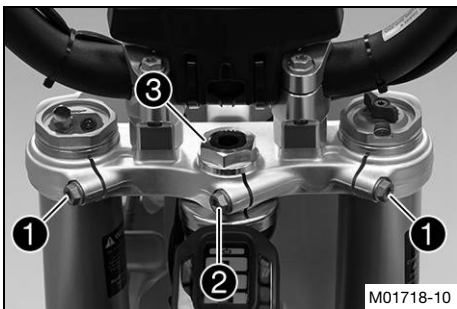

Preparatory work

- Raise the motorcycle with a lift stand. (📖 p. 45)

Main work

- Loosen screws ①.
- Loosen screw ②.
- Loosen and retighten nut ③.

Guideline

Nut, steering head	M20x1.5	10 Nm (7.4 lbf ft)
--------------------	---------	--------------------

- Using a plastic hammer, tap lightly on the upper triple clamp to avoid stresses.
- Tighten screw ②.

Guideline

Screw, top triple clamp	M8	20 Nm (14.8 lbf ft)
-------------------------	----	---------------------

- Tighten screws ①.

Guideline

Screw, top triple clamp	M8	20 Nm (14.8 lbf ft)
-------------------------	----	---------------------

Finishing work

- Check the steering head bearing play. (📖 p. 51)
- Remove the motorcycle from the lift stand. (📖 p. 45)

13.13 Lubricating the steering head bearing 🛠️

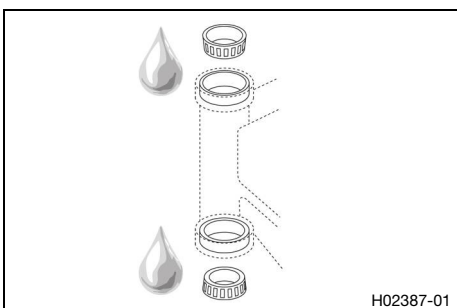

- Remove the lower triple clamp. 🛠️ (📖 p. 48)
- Install the lower triple clamp. 🛠️ (📖 p. 49)

Info

The steering head bearing is cleaned and lubricated in the course of removal and installation of the lower triple clamp.

13.14 Removing the start number plate

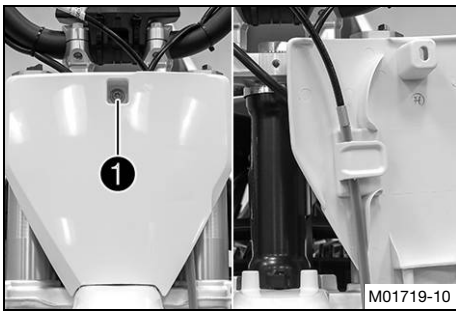

- Remove screw ①.
- Unhook the start number plate from the brake line and remove it.



13.15 Installing the start number plate



- Attach the start number plate to the brake line.
- Position the start number plate.
- ✓ Holding lugs ① engage in the fender.

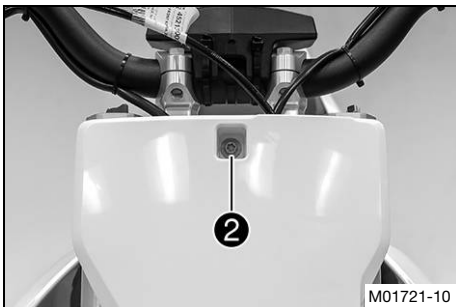

- Mount and tighten screw ②.

Guideline

Screw, start number plate	M6	4 Nm (3 lbf ft)
---------------------------	----	-----------------



13.16 Removing front fender

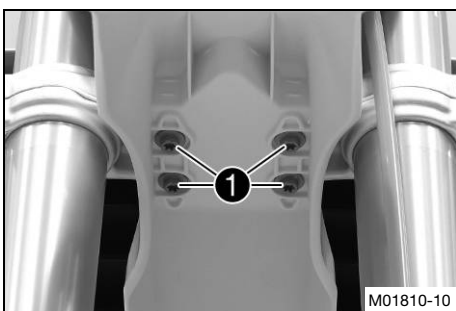

- Remove screws ①. Take off the front fender.



13.17 Installing front fender



- Position the fender with drill holes **1** in the holding lugs on the start number plate.

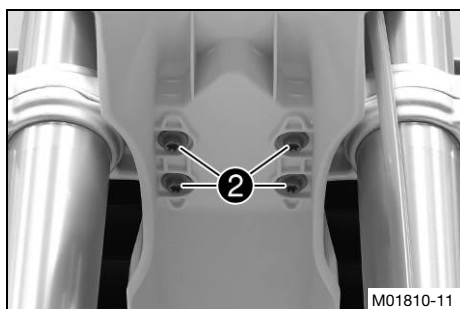

- Position front fender. Mount and tighten screws **2**.
- Guideline

Screw, fender	M6	6 Nm (4.4 lbf ft)
---------------	----	-------------------

13.18 Removing the shock absorber

Preparatory work

- Raise the motorcycle with a lift stand. (📖 p. 45)

Main work

- Note the installation position of the shock absorber.
- Pull brake line **1** out of the holder.
- Remove screw **2** and lower the link fork carefully.
- Remove screw **3**, push splash protector **4** to the side, and remove the shock absorber.

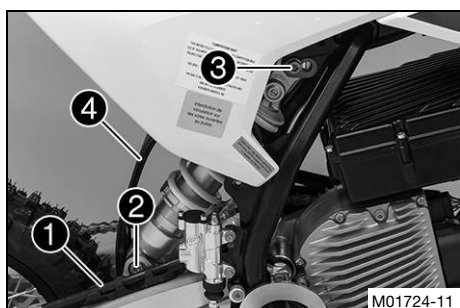

13.19 Installing the shock absorber



Warning

Danger of accidents Modifications to the suspension setting may seriously alter the handling characteristic.

- Ride slowly to start with after making adjustments to get the feel of the new handling characteristic.

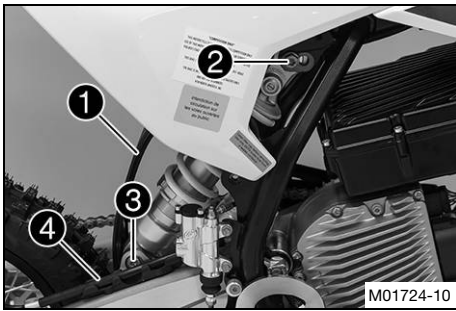

Main work

- Push splash protector **1** to the side.
- Mount the shock absorber with screw **2**.

Guideline

If necessary, observe the installation position noted during removal.

Screw, top shock absorber	M10	45 Nm (33.2 lbf ft) Loctite®243™
---------------------------	-----	--

- Lift the link fork, mount screw **3** and tighten it.

Guideline

Screw, bottom shock absorber	M10	45 Nm (33.2 lbf ft) Loctite®243™
------------------------------	-----	--

- Attach brake line **4** to the holder.

Finishing work

- Remove the motorcycle from the lift stand. (📖 p. 45)

13.20 Removing the seat

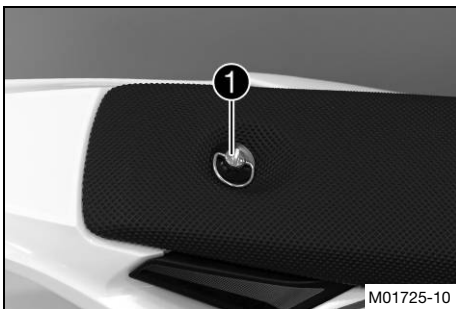

- Open quick release **1** and raise the rear of the seat.
- Pull back the seat and remove it.

13.21 Mounting the seat

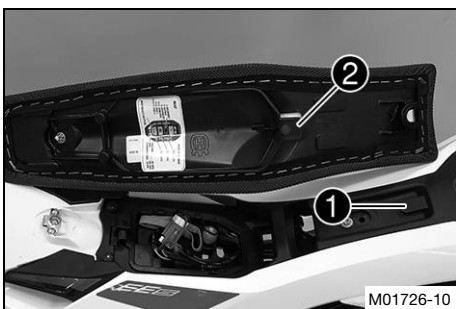

- Hook the seat onto holding lug **1**, lower the seat at the rear, and push it forward.
- ✓ Holding lug **2** hangs on the front fairing.

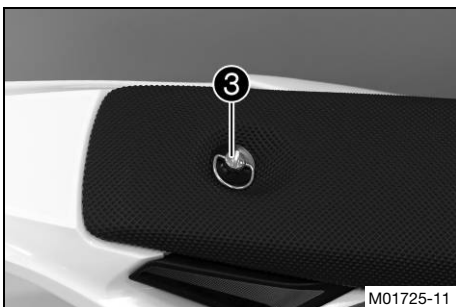

- Close quick release **3**.

13.22 Checking the chain for dirt

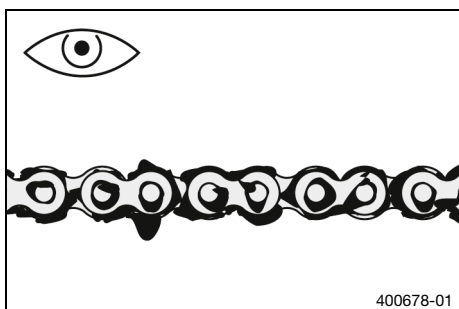

- Check the chain for coarse dirt accumulation.
 - » If the chain is very dirty:
 - Clean the chain. (📖 p. 56)

13.23 Cleaning the chain



Warning

Danger of accidents Lubricants on the tires reduces the road grip.

- Remove lubricants from the tires using a suitable cleaning agent.



Warning

Danger of accidents Oil or grease on the brake discs reduces the braking effect.

- Always keep the brake discs free of oil and grease.
- Clean the brake discs with brake cleaner when necessary.



Note

Environmental hazard Hazardous substances cause environmental damage.

- Dispose of oils, grease, cleaning agents, brake fluid etc. properly and in compliance with the applicable regulations.



Info

The service life of the chain depends largely on its maintenance.

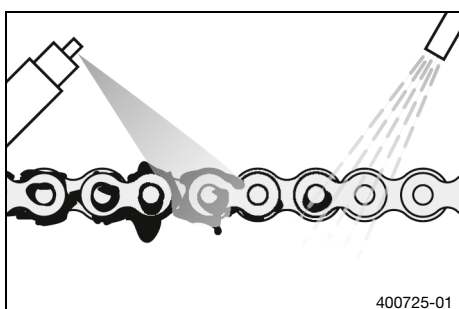

Preparatory work

- Raise the motorcycle with a lift stand. (📖 p. 45)

Main work

- Rinse off loose dirt with a soft jet of water.
- Remove old grease residue with chain cleaner.

Chain cleaner (📖 p. 99)

- After drying, apply chain spray.

Off-road chain spray (📖 p. 99)

Finishing work

- Remove the motorcycle from the lift stand. (📖 p. 45)

13.24 Checking the chain tension



Warning

Danger of accidents Incorrect chain tension damages components and results in accidents.

If the chain is tensioned too much, the chain, engine sprocket, rear sprocket, transmission and rear wheel bearings wear more quickly. Some components may break if overloaded.

If the chain is too loose, the chain may fall off the engine sprocket or the rear sprocket. As a result, the rear wheel locks or the engine will be damaged.

- Check the chain tension regularly.
- Set the chain tension in accordance with the specification.

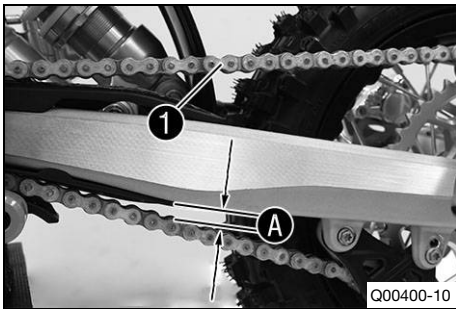

Preparatory work

- Raise the motorcycle with a lift stand. (📖 p. 45)

Main work

- Press the chain upward at the end of the chain sliding piece and determine chain tension **A**.



Info

The top part of chain **1** must be taut.

Chain wear is not always even, so you should repeat this measurement at different chain positions.

Chain tension	5 ... 8 mm (0.2 ... 0.31 in)
---------------	------------------------------

- » If the chain tension does not meet the specification:
 - Adjust the chain tension. (📖 p. 57)

Finishing work

- Remove the motorcycle from the lift stand. (📖 p. 45)



13.25 Adjusting the chain tension



Warning

Danger of accidents Incorrect chain tension damages components and results in accidents.

If the chain is tensioned too much, the chain, engine sprocket, rear sprocket, transmission and rear wheel bearings wear more quickly. Some components may break if overloaded.

If the chain is too loose, the chain may fall off the engine sprocket or the rear sprocket. As a result, the rear wheel locks or the engine will be damaged.

- Check the chain tension regularly.
- Set the chain tension in accordance with the specification.

Preparatory work

- Raise the motorcycle with a lift stand. (📖 p. 45)
- Check the chain tension. (📖 p. 57)

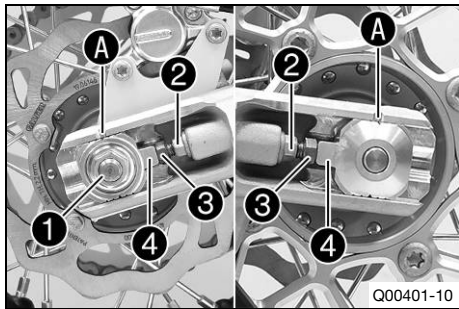

Main work

- Loosen nut ①.
- Loosen nuts ②.
- Adjust the chain tension by turning adjusting screws ③ left and right.

Guideline

Chain tension	5 ... 8 mm (0.2 ... 0.31 in)
Turn the adjusting screws ③ on the left and right so that the markings on the left and right chain adjusters ④ are in the same position relative to the reference marks A. The rear wheel is then correctly aligned.	

- Tighten nuts ②.
- Make sure that chain adjusters ④ are fitted correctly on adjusting screws ③.
- Tighten nut ①.

Guideline

Nut, rear wheel spindle	M12x1	40 Nm (29.5 lbf ft)
-------------------------	-------	---------------------

Finishing work

- Remove the motorcycle from the lift stand. (📖 p. 45)

13.26 Checking the chain, rear sprocket, motor sprocket, and chain guide

Preparatory work

- Raise the motorcycle with a lift stand. (📖 p. 45)

Main work

- Check the chain, rear sprocket, and motor sprocket for wear.
 - » If the chain, rear sprocket or motor sprocket is worn:
 - Change the drivetrain kit. 🛠️

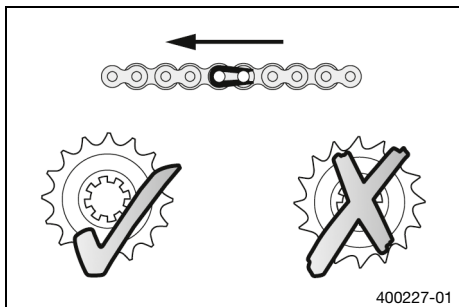

i Info

The motor sprocket, rear sprocket, and chain should always be replaced together. When fitting the chain joint, always make sure that the closed side of the joint faces forward (riding direction).

- Check the chain for wear.
 - » If the chain is worn:
 - Change the drivetrain kit. 🛠️

i Info

When a new chain is mounted, the rear sprocket and motor sprocket should also be changed. New chains wear out faster on old, worn sprockets.

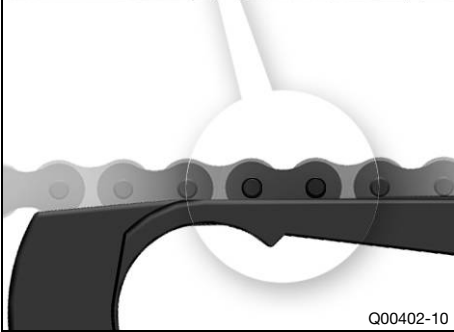
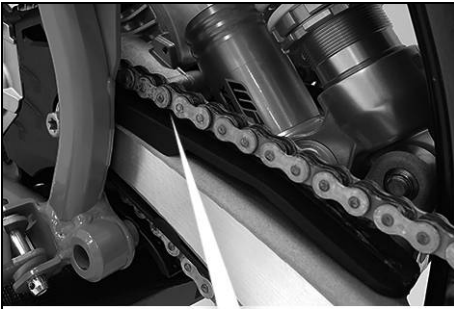

- Check the chain sliding guard for wear.
 - » If the ridge is worn down to the level of the main corpus:
 - Change the chain sliding guard. 🛠️
- Check that the chain sliding guard is firmly seated.
 - » If the chain sliding guard is loose:
 - Tighten the screw of the chain sliding guard.

Guideline

Screw, chain sliding guard	M6	3 Nm (2.2 lbf ft)
----------------------------	----	-------------------

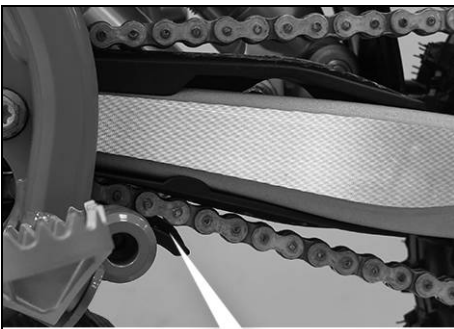

- Check the chain sliding piece for wear.
 - » If the lower edge of the chain pins is in line with or below the chain sliding piece:
 - Change the chain sliding piece. 🛠️
- Check that the chain sliding piece is firmly seated.
 - » If the chain sliding piece is loose:
 - Tighten screw on the chain sliding piece.

Guideline

Screw, chain sliding piece	M8	15 Nm (11.1 lbf ft)
----------------------------	----	---------------------

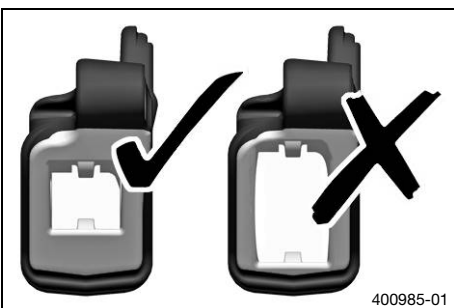

- Check the chain guide for wear.



Info

Wear can be seen on the front of the chain guide.

- » If the light part of the chain guide is worn:
 - Change the chain guide. 🛠️

13 SERVICE WORK ON THE CHASSIS

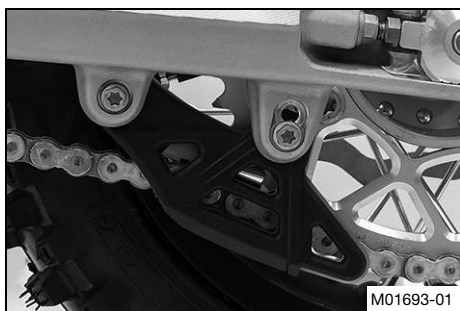

- Check that the chain guide is firmly seated.
 - » If the chain guide is loose:
 - Tighten the screws on the chain guide.

Guideline

Remaining screws, chassis	M6	10 Nm (7.4 lbf ft)
---------------------------	----	--------------------

Finishing work

- Remove the motorcycle from the lift stand. (📖 p. 45)

13.27 Adjusting the chain guide 🛠️

i Info

The size of the chain wheel varies with the number of teeth. The chain guide can be adjusted on small sprockets.

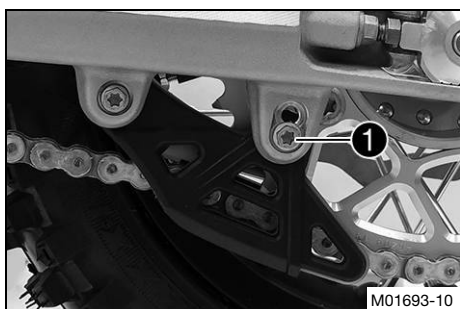

- Remove screw ❶.
- Position the chain guide.
- Mount and tighten the screw.

Guideline

Remaining screws, chassis	M6	10 Nm (7.4 lbf ft)
---------------------------	----	--------------------

13.28 Checking the frame 🛠️





- Check the frame for cracks and deformation.
 - » If the frame exhibits cracks or deformation due to a mechanical impact:
 - Change the frame. 🛠️

i Info

Always replace a frame that has been damaged due to a mechanical impact. Repair of the frame is not authorized by Husqvarna Motorcycles.

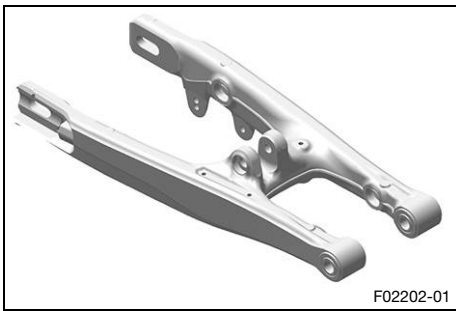
13.29 Checking the link fork



- Check the link fork for damage, cracking, and deformation.
 - » If the link fork shows signs of damage, cracking, or deformation:
 - Change the link fork. 

i Info

Always replace a damaged link fork. Husqvarna Motorcycles does not permit repairing link forks.



13.30 Checking the rubber grip

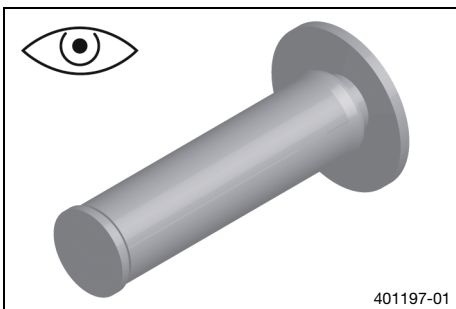

- Check the rubber grips on the handlebar for damage, wear, and looseness.

i Info

The rubber grips are vulcanized onto a sleeve on the left and onto the handle tube of the throttle grip on the right. The left sleeve is clamped onto the handlebar. The rubber grip can only be replaced with the sleeve or the throttle tube.

- » If a rubber grip is damaged, worn, or loose:
 - Change the rubber grip.

- Check that screw **1** is firmly seated.

Guideline

Screw, fixed grip	M4	5 Nm (3.7 lbf ft) Loctite®243™
-------------------	----	--

Diamond **A** must be located at the top.

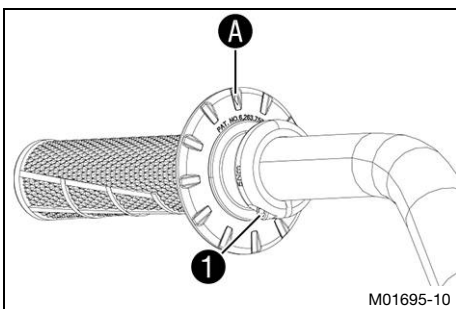

14.1 Checking play of handbrake lever



Warning

Danger of accidents The brake system fails in the event of overheating.

If there is no free travel on the hand brake lever, pressure builds up on the front brake circuit.

- Set the free travel on the hand brake lever in accordance with the specification.

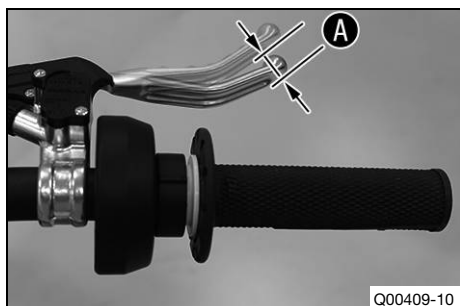

Q00409-10

- Push the handbrake lever forwards and check play **A**.

Play of hand brake lever	3 ... 5 mm (0.12 ... 0.2 in)
--------------------------	------------------------------

- » If the play does not meet specifications:
 - Adjust the play of the hand brake lever. (📖 p. 62)

14.2 Adjusting the play of the hand brake lever



Q00410-10

- Check the play of the handbrake lever. (📖 p. 62)
- Adjust the play of the hand brake lever using adjusting screw **1**.

Guideline

Play of hand brake lever	3 ... 5 mm (0.12 ... 0.2 in)
--------------------------	------------------------------

14.3 Adjusting the basic position of the hand brake lever

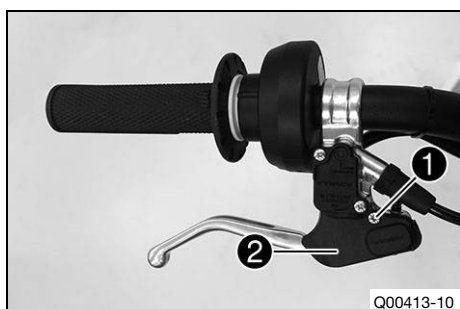

Q00413-10

- Remove screw **1**. Take off cover **2**.

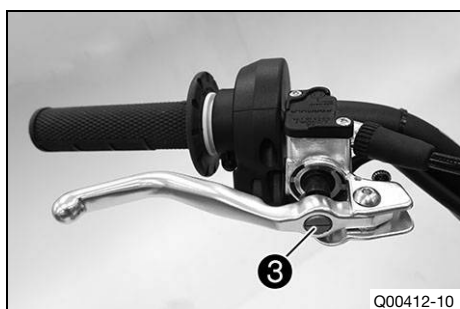

Q00412-10

- Check the play of the handbrake lever. (📖 p. 62)
- Adjust the basic position of the hand brake lever with adjusting screw **3** to the rider's hand size.

**Info**

Turn the adjusting screw clockwise to increase the distance between the hand brake lever and the handlebar.

Turn the adjusting screw counterclockwise to decrease the distance between the hand brake lever and the handlebar.

The range of adjustment is limited.

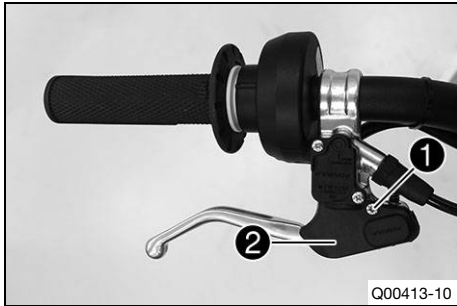

- Position cover **2**. Mount and tighten screw **1**.



14.4 Checking the brake discs

**Warning**

Danger of accidents Worn-out brake discs reduce the braking effect.

- Make sure that worn-out brake discs are replaced immediately. (Your authorized Husqvarna Motorcycles workshop will be glad to help.)

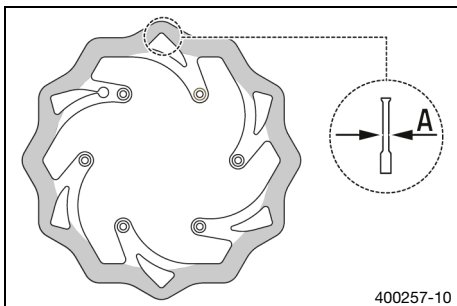

- Check the front and rear brake disc thickness at multiple points for the dimension **A**.

**Info**

Wear reduces the thickness of the brake disc around the contact surface of the brake linings.

Brake discs - wear limits	
front	2.2 mm (0.087 in)
rear	2.2 mm (0.087 in)

- » If the brake disc thickness is less than the specified value:
 - Change the front brake disc. 🛠️
 - Change the rear brake disc. 🛠️
- Check the front and rear brake discs for damage, cracking, and deformation.
 - » If the brake disc exhibits damage, cracking, or deformation:
 - Change the front brake disc. 🛠️
 - Change the rear brake disc. 🛠️



14.5 Checking the front brake fluid level



Warning

Danger of accidents An insufficient brake fluid level will cause the brake system to fail.

If the brake fluid level drops below the specified marking or the specified value, the brake system is leaking or the brake linings are worn down.

- Check the brake system and do not continue riding until the problem is eliminated. (Your authorized Husqvarna Motorcycles workshop will be glad to help.)



Warning

Skin irritation Brake fluid causes skin irritation.

- Keep brake fluid out of the reach of children.
- Wear suitable protective clothing and safety glasses.
- Do not allow brake fluid to come into contact with the skin, the eyes or clothing.
- Consult a doctor immediately if brake fluid has been swallowed.
- Rinse the affected area with plenty of water in the event of contact with the skin.
- Rinse eyes thoroughly with water immediately and consult a doctor if brake fluid comes into contact with the eyes.
- If brake fluid spills on to your clothing, change the clothing.



Warning

Danger of accidents Old brake fluid reduces the braking effect.

- Make sure that brake fluid for the front and rear brake is changed in accordance with the service schedule. (Your authorized Husqvarna Motorcycles workshop will be glad to help.)



Note

Environmental hazard Hazardous substances cause environmental damage.

- Dispose of oils, grease, cleaning agents, brake fluid etc. properly and in compliance with the applicable regulations.



Info

Never use DOT 5 brake fluid. It is silicone-based and purple in color. Oil seals and brake lines are not designed for DOT 5 brake fluid.

Avoid contact between brake fluid and painted parts. Brake fluid attacks paint.

Only use clean brake fluid from a sealed container.

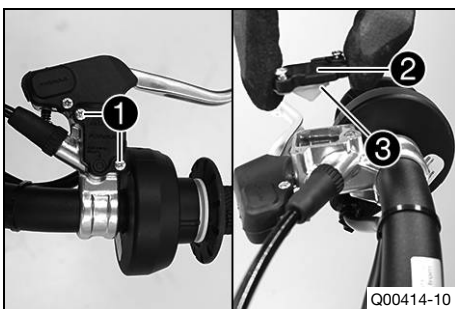

- Move the brake fluid reservoir mounted on the handlebar to a horizontal position.
- Remove screws ①.
- Take off cover ② with membrane ③.
- Check the brake fluid level.

Brake fluid level below reservoir rim	5 mm (0.2 in)
---------------------------------------	---------------

» If the brake fluid level does not meet specifications:

- Add front brake fluid. 🛠️ (p. 65)
- Position the cover with the membrane. Mount and tighten the screws.

**Info**

Immediately clean up any brake fluid that has overflowed or spilled using water.

14.6 Adding front brake fluid

**Warning**

Danger of accidents An insufficient brake fluid level will cause the brake system to fail.

If the brake fluid level drops below the specified marking or the specified value, the brake system is leaking or the brake linings are worn down.

- Check the brake system and do not continue riding until the problem is eliminated. (Your authorized Husqvarna Motorcycles workshop will be glad to help.)

**Warning**

Skin irritation Brake fluid causes skin irritation.

- Keep brake fluid out of the reach of children.
- Wear suitable protective clothing and safety glasses.
- Do not allow brake fluid to come into contact with the skin, the eyes or clothing.
- Consult a doctor immediately if brake fluid has been swallowed.
- Rinse the affected area with plenty of water in the event of contact with the skin.
- Rinse eyes thoroughly with water immediately and consult a doctor if brake fluid comes into contact with the eyes.
- If brake fluid spills on to your clothing, change the clothing.

**Warning**

Danger of accidents Old brake fluid reduces the braking effect.

- Make sure that brake fluid for the front and rear brake is changed in accordance with the service schedule. (Your authorized Husqvarna Motorcycles workshop will be glad to help.)

**Note**

Environmental hazard Hazardous substances cause environmental damage.

- Dispose of oils, grease, cleaning agents, brake fluid etc. properly and in compliance with the applicable regulations.

**Info**

Never use DOT 5 brake fluid. It is silicone-based and purple in color. Oil seals and brake lines are not designed for DOT 5 brake fluid.

Avoid contact between brake fluid and painted parts. Brake fluid attacks paint.

Only use clean brake fluid from a sealed container.

Preparatory work

- Check the front brake linings. ( p. 66)

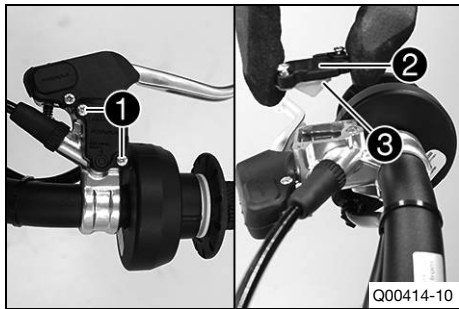

Main work

- Move the brake fluid reservoir mounted on the handlebar to a horizontal position.
- Remove screws ①.
- Take off cover ② with membrane ③.
- Correct the brake fluid level.

Guideline

Brake fluid level below reservoir rim	5 mm (0.2 in)
---------------------------------------	---------------

Brake fluid DOT 4 / DOT 5.1 (📖 p. 98)

- Position the cover with the membrane. Mount and tighten the screws.



Info

Immediately clean up any brake fluid that has overflowed or spilled using water.

14.7 Checking the front brake linings



Warning

Danger of accidents Worn-out brake linings reduce the braking effect.

- Ensure that worn-out brake linings are replaced immediately. (Your authorized Husqvarna Motorcycles workshop will be glad to help.)

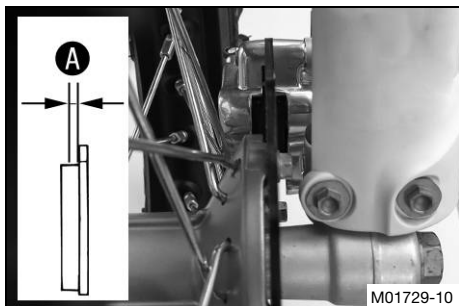

- Check the brake linings for minimum thickness A.

Minimum thickness A	≥ 1 mm (≥ 0.04 in)
---------------------	--------------------

- » If the minimum thickness is less than specified:
 - Change the brake linings of the front brake. 🛠️ (📖 p. 66)
- Check the brake linings for damage and cracking.
 - » If damage or wear is encountered:
 - Change the brake linings of the front brake. 🛠️ (📖 p. 66)

14.8 Changing the brake linings of the front brake 🛠️



Warning

Danger of accidents Incorrect servicing will cause the brake system to fail.

- Ensure that service work and repairs are performed professionally. (Your authorized Husqvarna Motorcycles workshop will be glad to help.)

**Warning****Skin irritation** Brake fluid causes skin irritation.

- Keep brake fluid out of the reach of children.
- Wear suitable protective clothing and safety glasses.
- Do not allow brake fluid to come into contact with the skin, the eyes or clothing.
- Consult a doctor immediately if brake fluid has been swallowed.
- Rinse the affected area with plenty of water in the event of contact with the skin.
- Rinse eyes thoroughly with water immediately and consult a doctor if brake fluid comes into contact with the eyes.
- If brake fluid spills on to your clothing, change the clothing.

**Warning****Danger of accidents** Old brake fluid reduces the braking effect.

- Make sure that brake fluid for the front and rear brake is changed in accordance with the service schedule. (Your authorized Husqvarna Motorcycles workshop will be glad to help.)

**Warning****Danger of accidents** Brake linings which have not been approved alter the braking efficiency.

Not all brake linings are tested and approved for Husqvarna motorcycles. The structure and friction coefficient of the brake linings, and thus their brake power, may vary greatly from that of original brake linings.

If brake linings are used that differ from the original equipment, compliance with the original homologation is not guaranteed. In this case, the vehicle no longer corresponds to its condition at delivery and the manufacturer warranty shall be void.

- Only use brake linings approved and recommended by Husqvarna motorcycles.

**Note****Environmental hazard** Hazardous substances cause environmental damage.

- Dispose of oils, grease, cleaning agents, brake fluid etc. properly and in compliance with the applicable regulations.

**Info**

Never use DOT 5 brake fluid. It is silicone-based and purple in color. Oil seals and brake lines are not designed for DOT 5 brake fluid.

Avoid contact between brake fluid and painted parts. Brake fluid attacks paint.

Only use clean brake fluid from a sealed container.

Preparatory work

- Raise the motorcycle with a lift stand. (📖 p. 45)

Main work

- Move the brake fluid reservoir mounted on the handlebar to a horizontal position.
- Remove screws ①.
- Take off cover ② with membrane ③.

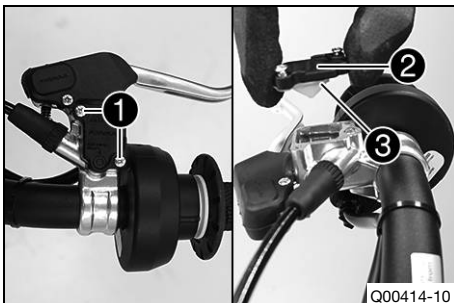

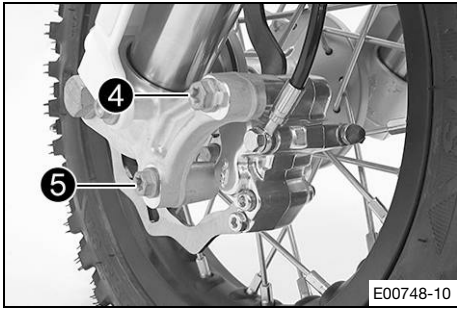

- Remove screw 4 and 5.
- Press back the brake linings by slightly tilting the brake caliper laterally on the brake disc. Carefully pull the brake caliper backward from the brake disc.
- Press the brake piston back into the basic position and ensure that brake fluid does not flow out of the brake fluid reservoir, extracting some if necessary.



- Remove lock ring 6.
- Remove screw 7.
- Remove the brake linings.
- Clean the brake caliper and the brake caliper bracket.
- Position the new brake linings.



Info

Always change the brake linings in pairs. Ensure that the brake linings are correctly positioned in the holding spring.



- Mount and tighten screw 7.

Guideline

Screw, brake linings	M5	8 Nm (5.9 lbf ft)
----------------------	----	-------------------

- Mount lock ring 6.



Warning

Danger of accidents Oil or grease on the brake discs reduces the braking effect.

- Always keep the brake discs free of oil and grease.
- Clean the brake discs with brake cleaner when necessary.

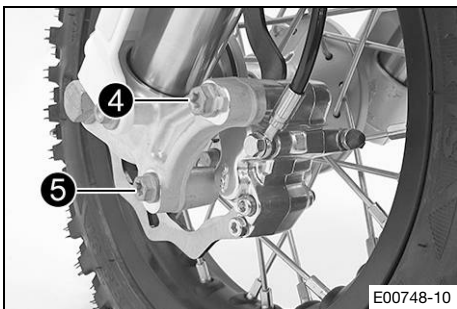

- Check the brake discs. (📖 p. 63)
- Position the brake caliper, mount screw 4, and tighten.

Guideline

Screw, front brake caliper	M8x60	20 Nm (14.8 lbf ft) Loctite®243™
----------------------------	-------	--

- Mount and tighten screw 5.

Guideline

Screw, front brake caliper	M8x40	20 Nm (14.8 lbf ft) Loctite®243™
----------------------------	-------	--

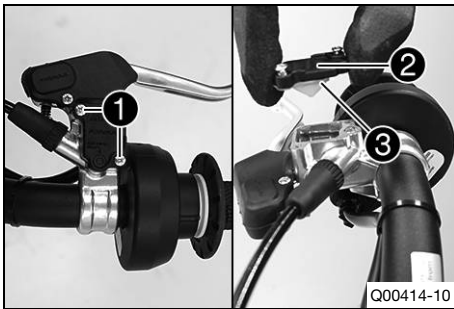

- Check the brake fluid level and correct if necessary.

Guideline

Brake fluid level below reservoir rim	5 mm (0.2 in)
---------------------------------------	---------------

Brake fluid DOT 4 / DOT 5.1 (📖 p. 98)

- Position cover ② with membrane ③.
- Mount and tighten screws ①.



Info

Immediately clean up any brake fluid that has overflowed or spilled using water.

Finishing work

- Remove the motorcycle from the lift stand. (📖 p. 45)

14.9 Checking the free travel of the foot brake lever



Warning

Danger of accidents The brake system fails in the event of overheating.

If there is no free travel on the foot brake lever, pressure builds up in the brake system on the rear brake.

- Set the free travel on the foot brake lever in accordance with the specification.

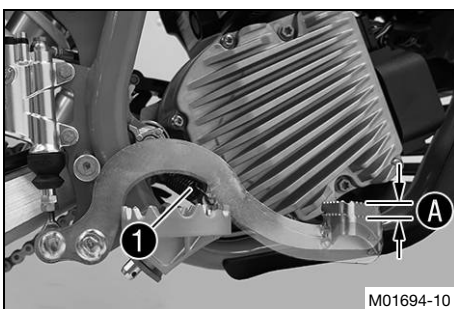

- Disconnect spring ①.
- Move the foot brake lever back and forth between the end stop and the foot brake cylinder piston bracket and check free travel ①.

Guideline

Free travel of foot brake lever	3 ... 5 mm (0.12 ... 0.2 in)
---------------------------------	------------------------------

» If the free travel does not meet specifications:

- Adjust the free travel of the hand brake lever. (📖 p. 69)
- Attach spring ①.

14.10 Adjusting the free travel of the foot brake lever



Warning

Danger of accidents The brake system fails in the event of overheating.

If there is no free travel on the foot brake lever, pressure builds up in the brake system on the rear brake.

- Set the free travel on the foot brake lever in accordance with the specification.

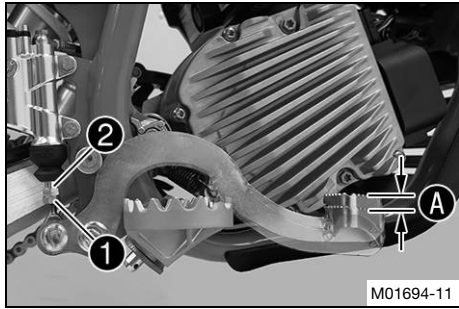

- Detach the foot brake lever spring.
- Loosen nut **1**.
- Turn push rod **2** accordingly until you have free travel **A**.

Guideline

Free travel of foot brake lever	3 ... 5 mm (0.12 ... 0.2 in)
---------------------------------	------------------------------

- Hold push rod **2** and tighten nut **1**.
- Attach the foot brake lever spring.
- Check whether the basic position of the foot brake lever is suitable for the rider.
 - » When the basic position of the foot brake lever needs to be adjusted:
 - Adjust the basic position of the foot brake lever. ↗ (📖 p. 70)

14.11 Adjusting the basic position of the foot brake lever ↗



Warning

Danger of accidents The brake system fails in the event of overheating.

If there is no free travel on the foot brake lever, pressure builds up in the brake system on the rear brake.

- Set the free travel on the foot brake lever in accordance with the specification.

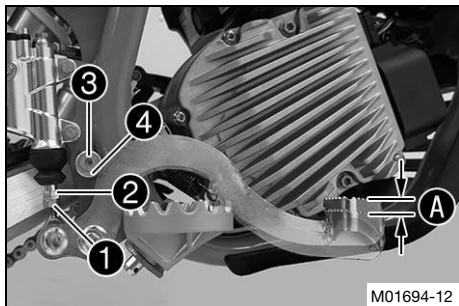

- Detach the foot brake lever spring.
- Loosen nut **1**.
- Turn back push rod **2** until free travel is at a maximum.
- For an individual adjustment of the basic position of the foot brake lever, loosen the screw **3** and turn the eccentric brake lever stop **4** accordingly.
- Tighten screw **3**.

Guideline

Remaining screws, chassis	M6	10 Nm (7.4 lbf ft)
---------------------------	----	--------------------

- Turn push rod **2** accordingly until you have free travel **A**.

Guideline

Free travel of foot brake lever	3 ... 5 mm (0.12 ... 0.2 in)
---------------------------------	------------------------------

- Hold push rod **2** and tighten nut **1**.
- Attach the foot brake lever spring.
- Check whether the basic position of the foot brake lever is suitable for the rider.

14.12 Checking the rear brake fluid level



Warning

Danger of accidents An insufficient brake fluid level will cause the brake system to fail.

If the brake fluid level drops below the specified marking or the specified value, the brake system is leaking or the brake linings are worn down.

- Check the brake system and ensure that nobody drives the vehicle before the problem is eliminated. (Your authorized Husqvarna Motorcycles workshop will be glad to help.)



Warning

Danger of accidents Old brake fluid reduces the braking effect.

- Make sure that brake fluid for the front and rear brake is changed in accordance with the service schedule. (Your authorized Husqvarna Motorcycles workshop will be glad to help.)

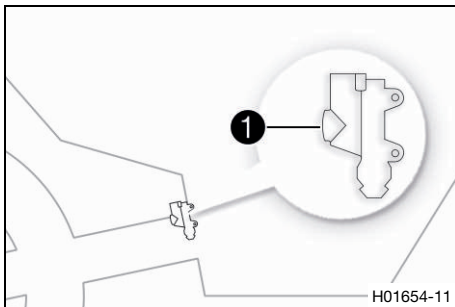

- Stand vehicle upright.
- Check the brake fluid level in level viewer ①.
 - » If the brake fluid level is below the **MIN** marking:
 - Add rear brake fluid. 🛠️ (p. 71)

14.13 Adding rear brake fluid 🛠️



Warning

Danger of accidents An insufficient brake fluid level will cause the brake system to fail.

If the brake fluid level drops below the specified marking or the specified value, the brake system is leaking or the brake linings are worn down.

- Check the brake system and ensure that nobody drives the vehicle before the problem is eliminated. (Your authorized Husqvarna Motorcycles workshop will be glad to help.)



Warning

Skin irritation Brake fluid causes skin irritation.

- Keep brake fluid out of the reach of children.
- Wear suitable protective clothing and safety glasses.
- Do not allow brake fluid to come into contact with the skin, the eyes or clothing.
- Consult a doctor immediately if brake fluid has been swallowed.
- Rinse the affected area with plenty of water in the event of contact with the skin.
- Rinse eyes thoroughly with water immediately and consult a doctor if brake fluid comes into contact with the eyes.
- If brake fluid spills on to your clothing, change the clothing.



Warning

Danger of accidents Old brake fluid reduces the braking effect.

- Make sure that brake fluid for the front and rear brake is changed in accordance with the service schedule. (Your authorized Husqvarna Motorcycles workshop will be glad to help.)



Note

Environmental hazard Hazardous substances cause environmental damage.

- Dispose of oils, grease, cleaning agents, brake fluid etc. properly and in compliance with the applicable regulations.



Info

Never use DOT 5 brake fluid. It is silicone-based and purple in color. Oil seals and brake lines are not designed for DOT 5 brake fluid.

Avoid contact between brake fluid and painted parts. Brake fluid attacks paint.

Only use clean brake fluid from a sealed container.

Preparatory work

- Raise the motorcycle with a lift stand. (📖 p. 45)
- Check the brake linings of the rear brake. (📖 p. 72)

Main work

- Remove screws ①.
- Take off cover ② with washer ③ and membrane ④.

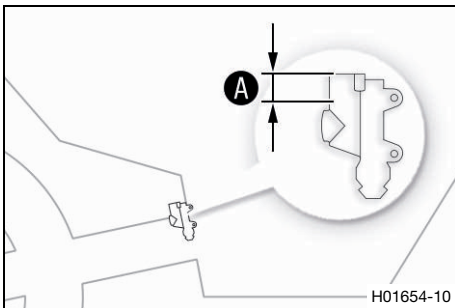
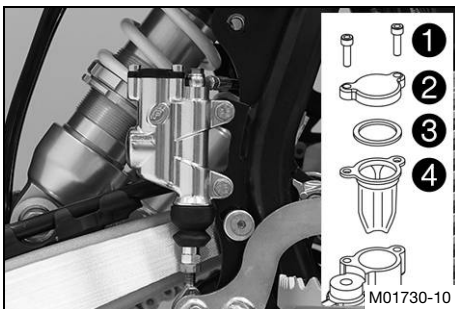

- Add brake fluid up to level A.

Guideline

Level A (brake fluid level below reservoir rim)	10 mm (0.39 in)
---	-----------------

Brake fluid DOT 4 / DOT 5.1 (📖 p. 98)

- Position cover with washer and membrane.
- Mount and tighten the screws.



Info

Immediately clean up any brake fluid that has overflowed or spilled using water.

Finishing work

- Remove the motorcycle from the lift stand. (📖 p. 45)

14.14 Checking the brake linings of the rear brake



Warning

Danger of accidents Worn-out brake linings reduce the braking effect.

- Ensure that worn-out brake linings are replaced immediately. (Your authorized Husqvarna Motorcycles workshop will be glad to help.)

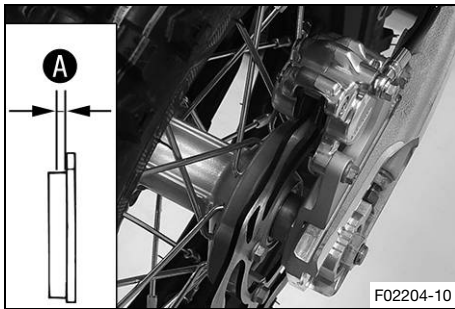

- Check the brake linings for minimum thickness **A**.

Minimum thickness A	$\geq 1 \text{ mm } (\geq 0.04 \text{ in})$
----------------------------	---

- » If the minimum thickness is less than specified:
 - Change the rear brake linings. 🛠️ (📖 p. 73)
- Check the brake linings for damage and cracking.
 - » If damage or wear is encountered:
 - Change the rear brake linings. 🛠️ (📖 p. 73)

14.15 Changing the rear brake linings 🛠️



Warning

Danger of accidents Incorrect servicing will cause the brake system to fail.

- Ensure that service work and repairs are performed professionally. (Your authorized Husqvarna Motorcycles workshop will be glad to help.)



Warning

Skin irritation Brake fluid causes skin irritation.

- Keep brake fluid out of the reach of children.
- Wear suitable protective clothing and safety glasses.
- Do not allow brake fluid to come into contact with the skin, the eyes or clothing.
- Consult a doctor immediately if brake fluid has been swallowed.
- Rinse the affected area with plenty of water in the event of contact with the skin.
- Rinse eyes thoroughly with water immediately and consult a doctor if brake fluid comes into contact with the eyes.
- If brake fluid spills on to your clothing, change the clothing.



Warning

Danger of accidents Old brake fluid reduces the braking effect.

- Make sure that brake fluid for the front and rear brake is changed in accordance with the service schedule. (Your authorized Husqvarna Motorcycles workshop will be glad to help.)



Warning

Danger of accidents Oil or grease on the brake discs reduces the braking effect.

- Always keep the brake discs free of oil and grease.
- Clean the brake discs with brake cleaner when necessary.



Warning

Danger of accidents Brake linings which have not been approved alter the braking efficiency.

Not all brake linings are tested and approved for Husqvarna motorcycles. The structure and friction coefficient of the brake linings, and thus their brake power, may vary greatly from that of original brake linings.

If brake linings are used that differ from the original equipment, compliance with the original homologation is not guaranteed. In this case, the vehicle no longer corresponds to its condition at delivery and the manufacturer warranty shall be void.

- Only use brake linings approved and recommended by Husqvarna motorcycles.



Note

Environmental hazard Hazardous substances cause environmental damage.

- Dispose of oils, grease, cleaning agents, brake fluid etc. properly and in compliance with the applicable regulations.



Info

Never use DOT 5 brake fluid. It is silicone-based and purple in color. Oil seals and brake lines are not designed for DOT 5 brake fluid.

Avoid contact between brake fluid and painted parts. Brake fluid attacks paint.

Only use clean brake fluid from a sealed container.

Preparatory work

- Raise the motorcycle with a lift stand. (📖 p. 45)

Main work

- Remove lock ring ①.
- Remove screw ②.
- Remove screw ③ and screw ④.

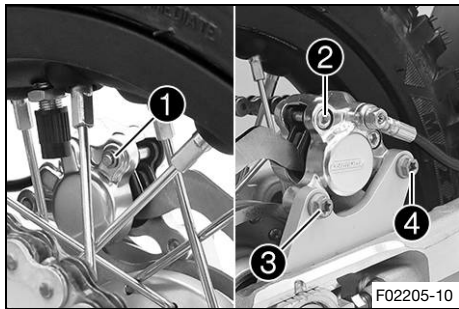

- Take off the brake caliper.



Info

Do not kink or damage the brake line.

- Remove the brake linings.
- Clean the brake caliper and the brake caliper bracket.
- Allow the brake caliper and the brake line to hang loosely to the side.
- Check the brake discs. (📖 p. 63)
- Remove screws ⑤.
- Take off cover ⑥ with washer ⑦ and membrane ⑧.
- Press the brake piston back into the basic position and ensure that brake fluid does not flow out of the brake fluid reservoir, extracting some if necessary.

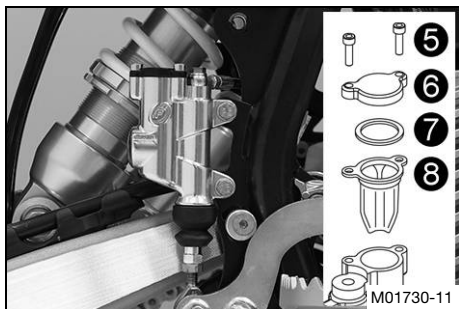

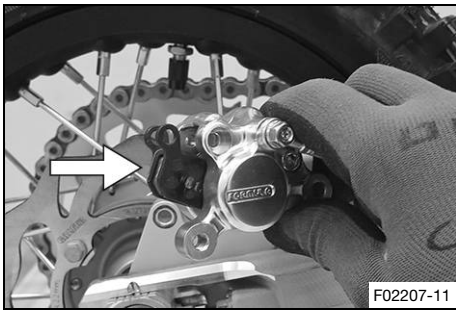

- Position the new brake linings.



Info

Always change the brake linings in pairs. Ensure that the brake linings are correctly positioned in the holding spring.

- Position the brake caliper on the brake disc.
 - ✓ The brake linings are correctly positioned.

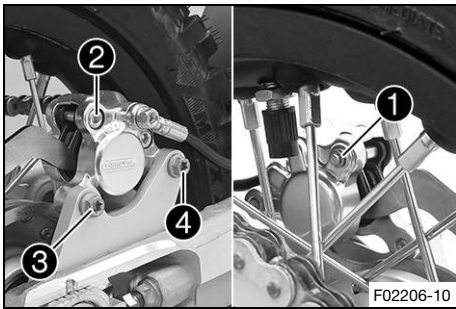

- Mount and tighten screw ③.

Guideline

Screw, rear brake caliper	M6x16	10 Nm (7.4 lbf ft) Loctite®243™
---------------------------	-------	---

- Mount and tighten screw ④.

Guideline

Screw, rear brake caliper	M6x40	10 Nm (7.4 lbf ft) Loctite®243™
---------------------------	-------	---

- Mount and tighten screw ②.

Guideline

Screw, brake linings	M5	8 Nm (5.9 lbf ft)
----------------------	----	-------------------

- Mount lock ring ①.

- Operate the foot brake lever repeatedly until the brake linings are in contact with the brake disc and there is a pressure point.

- Add brake fluid up to level ①.

Guideline

Level ① (brake fluid level below reservoir rim)	10 mm (0.39 in)
---	-----------------

Brake fluid DOT 4 / DOT 5.1 (📖 p. 98)

- Position cover with washer and membrane.
- Mount and tighten the screws.



Info

Immediately clean up any brake fluid that has overflowed or spilled using water.

Finishing work

- Remove the motorcycle from the lift stand. (📖 p. 45)

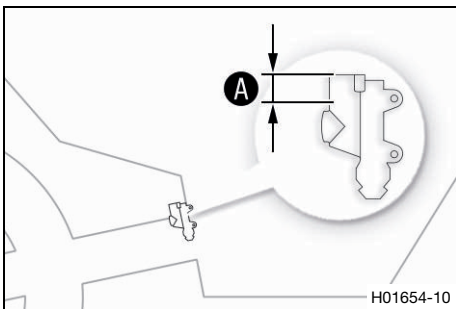

15.1 Removing the front wheel ↴

Preparatory work

- Raise the motorcycle with a lift stand. (📖 p. 45)

Main work

- Remove screw ❶.
- Loosen screws ❷.

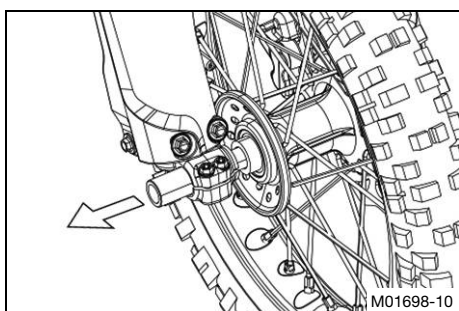
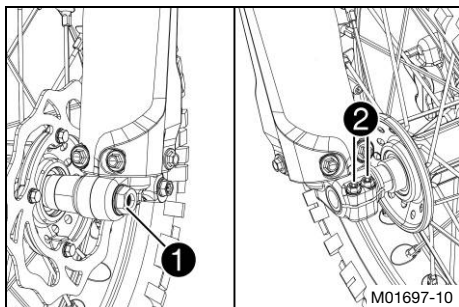

Warning

Danger of accidents Damaged brake discs reduce the braking effect.

- Always lay the wheel down in such a way that the brake disc is not damaged.

- Hold the front wheel and remove the wheel spindle. Take the front wheel out of the fork.



Info

Do not actuate the hand brake lever when the front wheel is removed.

- Remove spacers ❸.

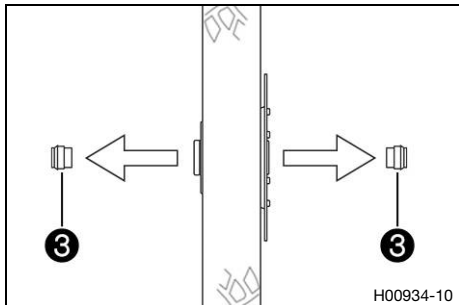

15.2 Installing the front wheel ↴



Warning

Danger of accidents Oil or grease on the brake discs reduces the braking effect.

- Always keep the brake discs free of oil and grease.
- Clean the brake discs with brake cleaner when necessary.

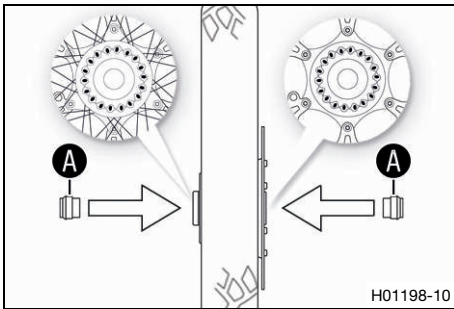

- Check the wheel bearing for damage and wear.
 - » If the wheel bearing is damaged or worn:
 - Change front wheel bearing. 🛠️
- Clean and grease the contact surfaces **A** of the spacers.

Long-life grease (📖 p. 99)

- Insert the spacers.

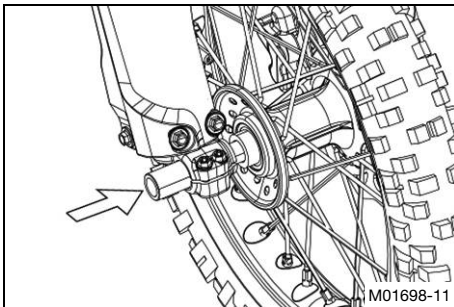

- Clean and grease the wheel spindle.

Long-life grease (📖 p. 99)

- Position the front wheel.
 - ✓ The brake linings are correctly positioned.
- Insert the wheel spindle.

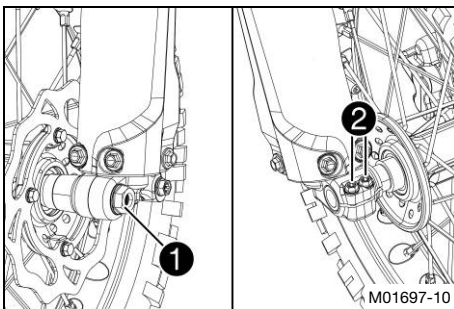

- Mount and tighten screw **1**.

Guideline

Screw, front wheel spindle	M10	40 Nm (29.5 lbf ft) Loctite®243™
----------------------------	-----	--

- Operate the hand brake lever several times until the brake linings are seated correctly against the brake disc.
- Remove the motorcycle from the lift stand. (📖 p. 45)
- Operate the front brake and compress the fork a few times firmly.
 - ✓ The fork legs straighten.

- Tighten screws **2**.

Guideline

Screw, fork stub	M6	10 Nm (7.4 lbf ft)
------------------	----	--------------------

15.3 Removing the rear wheel 🛠️

Preparatory work

- Raise the motorcycle with a lift stand. (📖 p. 45)

Main work

- Remove nut **1**.
- Take off chain adjuster **2**.

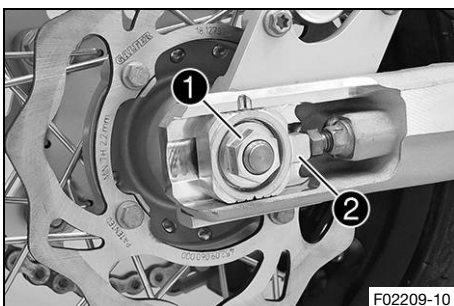



- Pull out wheel spindle ③ far enough to allow the rear wheel to be pushed forward.
- Push the rear wheel forward as far as possible. Remove the chain from the rear sprocket.

i Info
Cover the components to protect them against damage.

! Warning
Danger of accidents Damaged brake discs reduce the braking effect.

- Always lay the wheel down in such a way that the brake disc is not damaged.

- Hold the rear wheel and remove the wheel spindle. Take the rear wheel out of the link fork.

i Info
Do not operate the foot brake lever when the rear wheel is removed.

- Remove spacers ④.

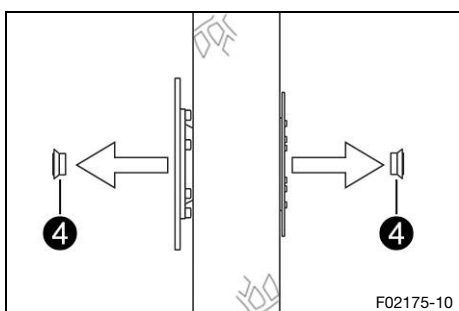

15.4 Installing the rear wheel ↩

! Warning
Danger of accidents Oil or grease on the brake discs reduces the braking effect.

- Always keep the brake discs free of oil and grease.
- Clean the brake discs with brake cleaner when necessary.

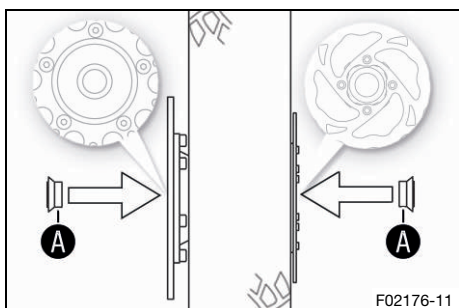

Main work

- Check the wheel bearing for damage and wear.
 - » If the wheel bearing is damaged or worn:
 - Change the rear wheel bearing. ↩
- Clean and grease the contact surfaces A of the spacers.

Long-life grease (📖 p. 99)

- Insert the spacers.

i Info
Insert the wide spacer on the left in the direction of travel.

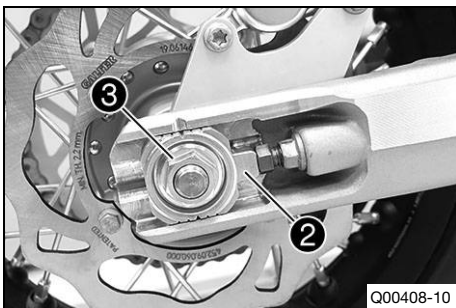

- Clean and grease wheel spindle **1**.
- Long-life grease (📖 p. 99)
- Position the rear wheel and insert wheel spindle.
 - ✓ The brake linings are correctly positioned.
 - Mount the chain.
 - Position chain adjuster **2** on both sides and push the wheel spindle in all the way.

- Mount nut **3**, but do not tighten it yet.
- Make sure that the chain adjusters are fitted correctly on the adjusting screws.
- Check the chain tension. (📖 p. 57)
- Tighten nut **3**.

Guideline

Nut, rear wheel spindle	M12x1	40 Nm (29.5 lbf ft)
-------------------------	-------	---------------------

- Operate the foot brake lever repeatedly until the brake linings are in contact with the brake disc and there is a pressure point.

Finishing work

- Remove the motorcycle from the lift stand. (📖 p. 45)



15.5 Checking the tire condition

i Info
Only mount tires approved and/or recommended by Husqvarna Motorcycles. Other tires could have a negative effect on handling characteristics. The type, condition, and pressure of the tires all have a major impact on the handling characteristic of the motorcycle. The tires mounted on the front and rear wheels must have a similar profile. Worn tires have a negative effect on handling characteristics, especially on wet surfaces.

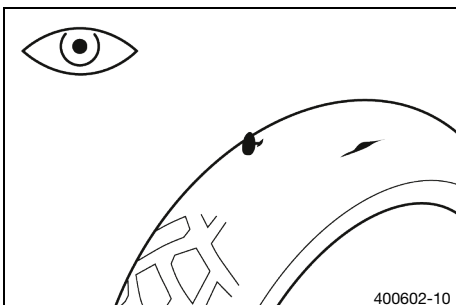

- Check the front and rear tires for cuts, embedded objects, and other damage.
 - » If the tires have cuts, run-in objects, or other damage:
 - Change the tires. 🛠️

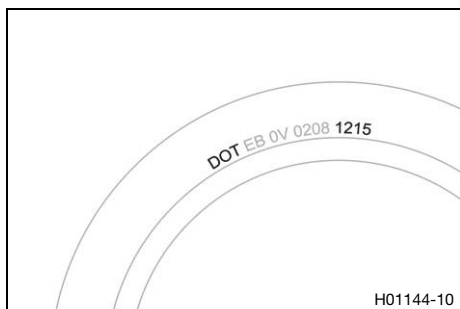

- Check the tire age.

i Info

The tire date of manufacture is usually contained in the tire label and is indicated by the last four digits of the **DOT** number. The first two digits indicate the week of manufacture and the last two digits the year of manufacture.

Husqvarna Motorcycles recommends that the tires be changed after 5 years at the latest, regardless of the actual wear.

- » If the tires are more than five years old:
 - Change the tires. 🛠️

15.6 Checking tire pressure

i Info

Low tire pressure leads to abnormal wear and overheating of the tire. Correct tire pressure ensures optimal riding comfort and maximum tire service life.

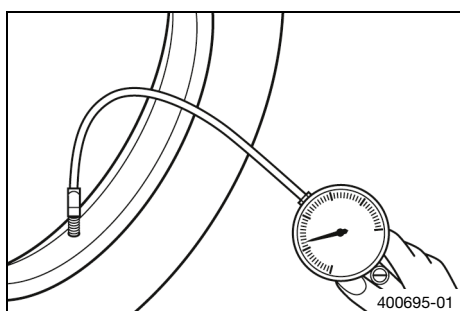

- Remove protection cap.
- Check tire pressure when the tires are cold.

Offroad tire pressure	
front	1.0 bar (15 psi)
rear	1.0 bar (15 psi)

- » If the tire pressure does not meet specifications:
 - Correct tire pressure.
- Mount the protection cap.

15.7 Checking spoke tension



Warning

Danger of accidents Incorrectly tensioned spokes impair the handling characteristic and result in secondary damage.

The spokes break due to being overloaded if they are too tightly tensioned. If the tension in the spokes is too low, then lateral and radial run-out will form in the wheel. Other spokes will become looser as a result.

- Check spoke tension regularly, and in particular on a new vehicle. (Your authorized Husqvarna Motorcycles workshop will be glad to help.)

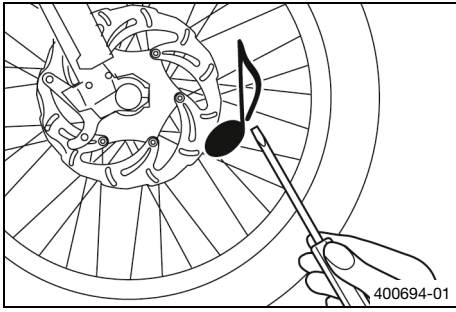

- Strike each spoke briefly using a screwdriver blade.



Info

The frequency of the sound depends on the spoke length and spoke diameter. If you hear different tone frequencies from different spokes of equal length and diameter, this is an indication of different spoke tensions.

You should hear a high note.

- » If the spoke tension differs:
 - Correct the spoke tension. 🛠️

- Check the spoke torque.

Guideline

Spoke nipple	M3.5	3 Nm (2.2 lbf ft)
--------------	------	-------------------

Torque wrench kit (58429094000)



16.1 Overview of battery charger

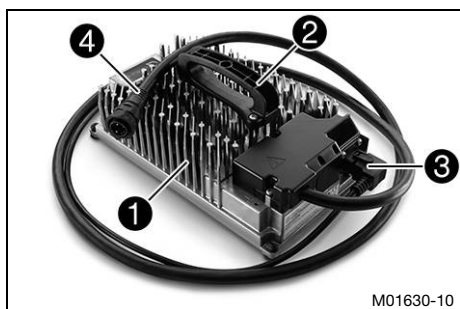

- ① Battery charger
- ② Carrying handle
- ③ Power cord
- ④ Charging cable

16.2 Positioning the battery charger



Warning

Risk of injury If the battery charger is used incorrectly, its intrinsic safety cannot be guaranteed. The battery charger is only suitable for use with a Powerpack HV.

- Only use the battery charger with a Powerpack HV.
- Only operate the battery charger using household sockets with a ground conductor.
- Do not use any additional adapters or extensions.
- Follow the applicable safety instructions of the power connection.



Warning

Risk of injury There is a risk of electric shock if the battery charger or the cables have been manipulated or damaged.

The battery charger does not contain any parts which require maintenance.

- Do not modify the battery charger or the cables.
- Only use original cables.
- Never open the battery charger housing.
- Do not insert any objects into the battery charger housing from the outside.
- Do not use the battery charger if cables, plugs, or parts of the battery charger have been damaged or are soiled.

i Info

The battery charger contains sensitive electronics and must be handled with appropriate care. The battery charger may be damaged or destroyed if it is dropped, knocked or otherwise subject to mechanical overload.

When transporting the battery charger, ensure appropriate means of securing the cargo.

Damage caused due to improper handling or improper transport is excluded from the manufacturer warranty.

The battery charger only meets **IP66** when the original power cord is being used.

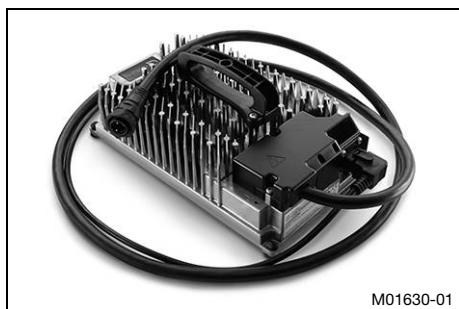

- Place the battery charger on a firm, level, and horizontal surface.

i Info
Despite **IP66**, the battery charger should only be used in a dry environment, as moisture may penetrate into the interior when connecting and disconnecting the connections.

- Check the battery charger and mains cable for external damage.
- Ensure the battery charger is adequately ventilated.
- Use the battery charger in the temperature range permitted.

Guideline

Ambient temperature	-20 ... 50 °C (-4 ... 122 °F)
Temperature range of the Powerpack LV	0 ... 50 °C (32 ... 122 °F)
Do not operate the battery charger directly in a warm environment if it has previously been stored in a cold environment.	

i Info
The change in temperature can cause moisture to condense on the battery charger.

- Ensure that the power plug for the battery charger always remains easily accessible.

16.3 Charging the Powerpack LV



Caution

Danger of burns The metal housing of the battery charger becomes hot during operation.

- Only touch the battery charger by the carrying handle.
- After charging, allow the battery charger to cool before stowing it away.

Note

Material damage The power supply will be damaged in the event of an overload.

- Ensure that the power outlet can supply the steady current required and is protected by a suitable fuse.

Fuse protection at mains voltage 100 V minimum	15 A
Fuse protection at mains voltage 120 V minimum	13 A
Fuse protection at mains voltage 230 V minimum	10 A



Note

Environmental hazard A lithium-ion battery (Powerpack HV) contains components and elements that are harmful to the environment.

- Never throw a Powerpack HV into the household trash.
- Dispose of the Powerpack HV properly and in compliance with the applicable regulations. (Your authorized Husqvarna Motorcycles workshop will be glad to help.)

i Info

Do not activate the vehicle while the battery charger is connected to the Powerpack LV. If the vehicle is activated during the charging process, the vehicle switches to the fault state.

i Info

If the temperature of the Powerpack LV exceeds the permissible value while it is being charged, the battery charger stops charging. The fault is displayed on the multifunctional element. After the temperature of the Powerpack LV returns to the permissible range, charging is resumed automatically.

Preparatory work

- Position the battery charger. (📖 p. 82)
- Press and hold the On/Off button until the multifunctional element goes out.
- Remove the magnetic switch ☒ from the holder on the handlebar.

Main work

- Remove charging socket protection cap ❶.

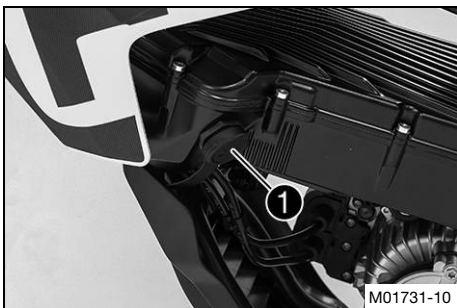

- Remove charging plug protection cap ❷.

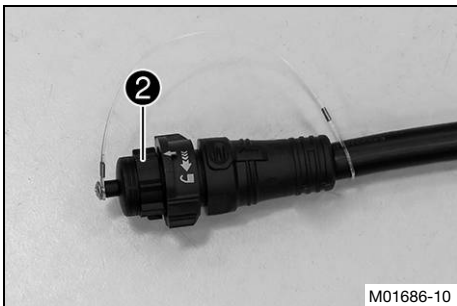

- Make sure that all plugs, bushings, and cables are dry.

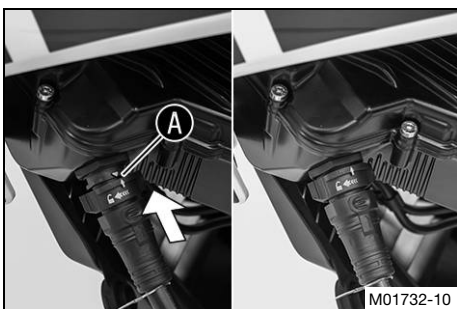

Warning

Risk of injury The intrinsic safety of the Powerpack HV can only be guaranteed if the original battery charger is used.

The Powerpack HV may only be charged with the original battery charger.

- Only use the original battery charger to charge the Powerpack HV.

- Connect the battery charger to the Powerpack LV.

Guideline

Observe plug marking **A**.

Insert the plug straight so that the contacts are not bent.

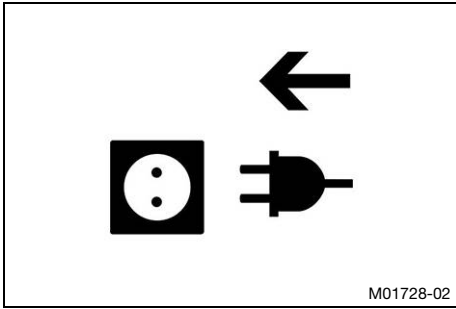

- Connect the power plug for the battery charger to the mains connection.
- ✓ Charging starts automatically.
- ✓ The multifunctional element indicates the charging level.
- Monitor the charging level of the Powerpack LV on the multifunctional element (📖 p. 20).



Info

It is recommended not to leave the vehicle unattended for long periods during charging. When charging is complete, three beeps are emitted and all segments of the charging level indicator light up continuously.

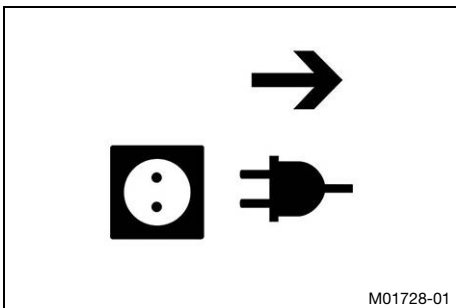

- Press and hold the On/Off button until the multifunctional element goes out.
- Make sure that all plugs, bushings, and cables are dry.
- Disconnect the battery charger power plug from the mains connection.

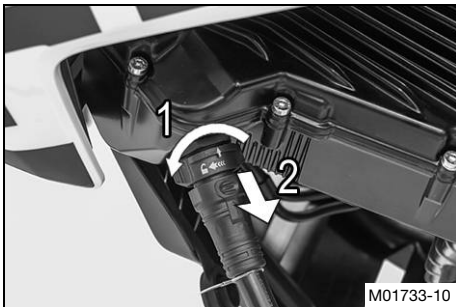

- Unlock the charging plug lock counterclockwise and disconnect the charging cable from the Powerpack LV.

Guideline

Pull on the structured part of the plug. Do not pull on the cable.

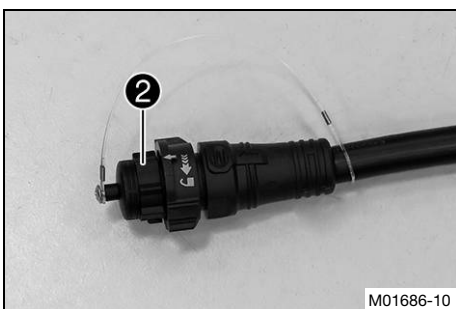

- Mount charging plug protection cap ②.

16 POWERPACK LV, BATTERY CHARGER

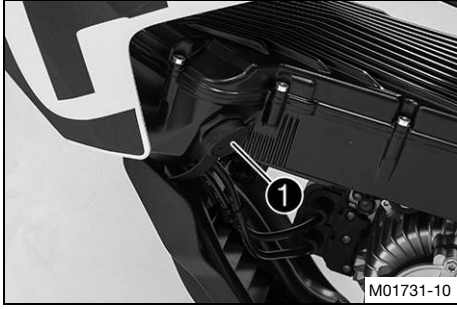

- Check charging socket protection cap ①.
 - » If the charging socket protection cap is dirty:
 - Clean the charging socket protection cap without water or compressed air.
 - » If the charging socket protection cap is damaged or worn:
 - Change the charging socket protection cap.
- Mount the charging socket protection cap.

17.1 Cooling

The Powerpack LV ① and the electric motor ② are air-cooled. Cooling is effected by the air stream. The lower the speed, the less the cooling effect. Dirty cooling fins also reduce the cooling effect.

18.1 Cleaning the motorcycle

Note

Material damage Components become damaged or destroyed if a pressure cleaner is used incorrectly. The high pressure forces water into the electrical components, connectors, throttle cables, and bearings, etc. Pressure which is too high causes malfunctions and destroys components.

- Do not direct the water jet directly on to electrical components, connectors, throttle cables or bearings.
- Maintain a minimum distance between the nozzle of the pressure cleaner and the component.

Minimum clearance 60 cm (23.6 in)



Note

Environmental hazard Hazardous substances cause environmental damage.

- Dispose of oils, grease, cleaning agents, brake fluid etc. properly and in compliance with the applicable regulations.



Info

Clean the motorcycle regularly to maintain its value and appearance over a long period. Avoid direct sunshine when cleaning the motorcycle.

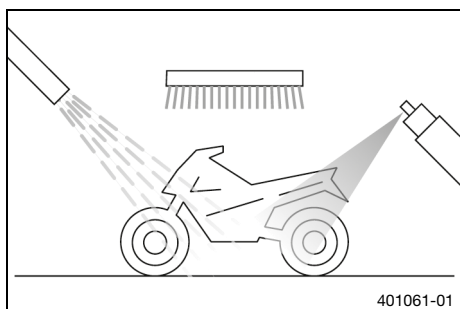

- Remove the coarse dirt particles with a gentle water jet.
- Spray the heavily soiled parts with a normal commercial motorcycle cleaner and clean using a brush.

Motorcycle cleaner (📖 p. 99)



Info

Use warm water containing normal motorcycle cleaner and a soft sponge. Never apply motorcycle cleaner to the dry motorcycle. Always rinse the motorcycle with water before use.

- After rinsing the motorcycle with a gentle spray of water, allow it to dry thoroughly.



Warning

Danger of accidents Moisture and dirt impair the brake system.

- Explain to your child that he or she must brake carefully several times to dry out and remove dirt from the brake linings and the brake discs.

- After cleaning, your child should ride a short distance until the brake system has dried through careful braking.



Info

The heat causes the water to evaporate even in inaccessible parts of the vehicle.

- After the motorcycle has cooled down, lubricate all moving parts and pivot points.
- Clean the chain. (📖 p. 56)

- Treat bare metal (except for brake discs) with a corrosion inhibitor.

Preserving materials for paints, metal and rubber (📖 p. 99)

- Treat all plastic parts and powder-coated parts with a mild cleaning and care product.

Special cleaner for glossy and matte paint finishes, metal and plastic surfaces (📖 p. 99)



19.1 Storage

i Info

If you plan to garage the motorcycle for a longer period, perform the following steps or have them performed.

Before storing the motorcycle, check all parts for function and wear. If service, repairs, or replacements are necessary, you should do this during the storage period (less workshop overload). In this way, you can avoid long workshop waiting times at the start of the new season.

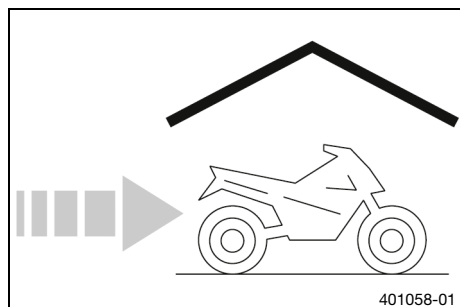

- Clean the motorcycle. (📖 p. 88)
- Check tire pressure. (📖 p. 80)
- Charge the Powerpack LV. (📖 p. 83)

Guideline

Stop charging at 30%.

- ✓ The last segment lights up yellow.

i Tip

If necessary, ride the vehicle to deplete the Powerpack LV sufficiently.

- Store the vehicle in a dry location that is not subject to large fluctuations in temperature.

Guideline

Ideal storage temperature	10 ... 20 °C (50 ... 68 °F)
---------------------------	-----------------------------

i Info

Husqvarna Motorcycles recommends jacking up the motorcycle.

- Raise the motorcycle with a lift stand. (📖 p. 45)
- Cover the motorcycle with a tarp or cover that is permeable to air.

i Info

Do not use non-porous materials since they prevent humidity from escaping, thus causing corrosion.

19.2 Preparing for use after storage

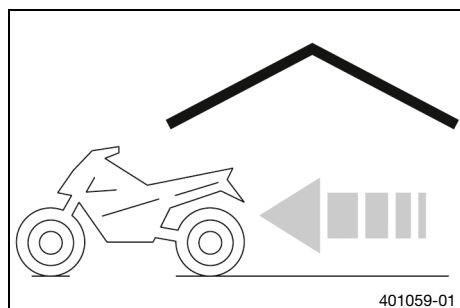

- Remove the motorcycle from the lift stand. (📖 p. 45)
- Charge the Powerpack LV. (📖 p. 83)
- Perform checks and maintenance measures when preparing for use. (📖 p. 24)
- Take a test ride.

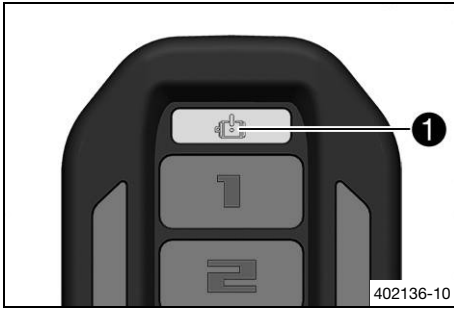

Faults are indicated by malfunction indicator lamp ① and by acoustic signals that sound at the same time.

i Tip

As a first measure for all faults, switch off the vehicle using the On/Off button, wait 1 minute, and switch it on again.

If a fault is not eliminated by the measures specified here, or a blink code is not listed, an authorized Husqvarna Motorcycles workshop will be happy to help you.

i Info

The pause between the signals of the 1st digit is 0.25 seconds.

The pause between the 1st and 2nd digits is 1 second.

The pause between the signals of the 2nd digit is also 0.25 seconds.

The pause until the blink code repeats is 3 seconds.

Faults	Possible cause	Action
Blink code 11	Fault in the throttle grip	– Check the throttle grip for damage. 🛠️
Blink code 12	Fault in the throttle grip	– Check the throttle grip for damage. 🛠️
Blink code 14	Throttle grip actuated during activation	– Do not operate the throttle grip during activation.
Blink code 24	System temperature too high	– Allow the vehicle to cool down, clean the cooling surfaces.
Blink code 31	Fault during charging	– Disconnect the battery charger from the vehicle and mains connection, wait 1 minute, restart the charging process.
Blink code 33	System temperature too high	– Allow the vehicle to cool down, clean the cooling surfaces.
Blink code 34	System temperature too low	– Park the vehicle in a warmer environment.
Blink code 41	Vehicle moved during activation	– Do not move the vehicle during activation.
Blink code 42	Motor speed outside the permissible range	– Do not roll backward with the vehicle.
Blink code 43	System temperature too high	– Allow the vehicle to cool down, clean the cooling surfaces.
Blink code 71	Fault during charging	– Disconnect the battery charger from the vehicle and mains connection, wait 1 minute, restart the charging process. – Replace the charging cable. 🛠️
Blink code 73	Fault during charging	– Disconnect the battery charger from the vehicle and mains connection, wait 1 minute, restart the charging process. – Replace the charging cable. 🛠️
Blink code 83	Transport mode activated	– Deactivate transport mode. 🛠️

Faults	Possible cause	Action
Blink code 85	Fault during charging	<ul style="list-style-type: none">– Disconnect the battery charger from the vehicle and mains connection, wait 1 minute, restart the charging process.– Replace the charging cable. 🛠️
Blink code 88	Fault in the On/Off button	<ul style="list-style-type: none">– Deactivate the vehicle, wait 4 minutes, reactivate the vehicle.– Check the On/Off button for damage. 🛠️

21.1 Engine

Design	Brushless DC motor
Nominal power	2 kW (3 hp)
Maximum electric power	5 kW (7 hp)
Recuperation	available in ride mode 3 and 6
Maximum torque depending on ride mode approx.	
Ride mode 1	6 Nm (4.4 lbf ft)
Ride mode 2	9 Nm (6.6 lbf ft)
Ride mode 3	10.5 Nm (7.74 lbf ft)
Ride mode 4	12 Nm (8.9 lbf ft)
Ride mode 5	13.8 Nm (10.18 lbf ft)
Ride mode 6	13.8 Nm (10.18 lbf ft)
Theoretical maximum speed (unloaded)	
Ride mode 1	12 km/h (7.5 mph)
Ride mode 2	21 km/h (13 mph)
Ride mode 3	50 km/h (31.1 mph)
Ride mode 4	71 km/h (44.1 mph)
Ride mode 5	73 km/h (45.4 mph)
Ride mode 6	73 km/h (45.4 mph)
Maximum motor speed	6,000 rpm
Cooling	Air cooling

21.2 Chassis

Frame	Central tube frame of chrome molybdenum steel tubing, powder-coated
Fork	WP XACT 5235
Shock absorber	WP XACT 5735
Suspension travel	
front	205 mm (8.07 in)
rear	185 mm (7.28 in)
Fork offset	22 mm (0.87 in)
Brake system	
front	Disc brake with 4-piston brake caliper
rear	Disc brake with 2-piston brake caliper
Brake disc diameters	
front	160 mm (6.3 in)
rear	160 mm (6.3 in)
Brake discs - wear limits	
front	2.2 mm (0.087 in)
rear	2.2 mm (0.087 in)
Offroad tire pressure	
front	1.0 bar (15 psi)
rear	1.0 bar (15 psi)
Secondary drive ratio	08:46

Chain	1/2 x 3/16"
Rear sprockets available	45, 46, 47
Steering head angle	66°
Wheelbase	1,032 ± 10 mm (40.63 ± 0.39 in)
Seat height unloaded	615 ... 665 mm (24.21 ... 26.18 in)
Ground clearance unloaded	207 ... 252 mm (8.15 ... 9.92 in)
Ready-to-ride weight approx.	40.5 kg (89.3 lb.)

21.3 Electrical system

Air-cooled lithium-ion battery (Powerpack LV)	45445053200	Voltage (nominal): 43.2 V Capacity: 907 Wh Approx. charging time, 0% to 80%: 45 min Approx. charging time, 0% to 100%: 70 min Maintenance-free
Battery charger for Powerpack LV	45429074000	Nominal voltage: 100 ... 240 V Grid frequency: 50 ... 60 Hz Power: 900 W

21.4 Tires

Front tire	Rear tire
60/100 - 12 36M TT MAXXIS MAXX CROSS SI	2.75 - 10 38J TT MAXXIS MAXX CROSS SI
The tires specified represent one of the possible series production tires. Additional information is available in the Service section under: www.husqvarna-motorcycles.com	

21.5 Fork

Fork article number	07.18.6U.02	
Fork	WP XACT 5235	
Rebound damping		
Comfort	15 clicks	
Standard	12 clicks	
Sport	10 clicks	
Air pressure	2 bar (29 psi)	
Fork length	685 mm (26.97 in)	
Spring length with preload spacer(s)	337.5 mm (13.287 in)	
Oil capacity external mechanism left	25 ± 5 ml (0.85 ± 0.17 fl. oz.)	Fork oil (SAE 4) (48601166S1) (📖 p. 98)
Oil capacity, right cartridge	225 ml (7.61 fl. oz.)	Fork oil (SAE 4) (48601166S1) (📖 p. 98)
Grease capacity, left cartridge	6 g (0.21 oz)	Special grease (00062010053) (📖 p. 99)

21.6 Shock absorber

Shock absorber article number	03.18.7U.02
Shock absorber	WP XACT 5735
Low-speed compression damping	
Comfort	18 clicks
Standard	15 clicks
Sport	12 clicks
High-speed compression damping	
Comfort	2.5 turns
Standard	2 turns
Sport	1.5 turns
Rebound damping	
Comfort	17 clicks
Standard	15 clicks
Sport	13 clicks
Spring preload	3 mm (0.12 in)
Spring rate	
Weight of rider: 15 ... 25 kg (33 ... 55 lb.)	25 N/mm (143 lb/in)
Weight of rider (standard): 25 ... 35 kg (55 ... 77 lb.)	30 N/mm (171 lb/in)
Weight of rider: 35 ... 45 kg (77 ... 99 lb.)	35 N/mm (200 lb/in)
Spring length	130 mm (5.12 in)
Gas pressure	10 bar (145 psi)
Static sag	12 mm (0.47 in)
Riding sag	80 mm (3.15 in)
Fitted length	275 mm (10.83 in)
Shock absorber oil	Shock absorber fluid (SAE 2.5) (50180751S1) (📖 p. 98)

21.7 Chassis tightening torques

Screw, brake line clamp on fork protector	EJOT PT®K60x20-AL	2 Nm (1.5 lbf ft)
Screw, brake line clamp on link fork	EJOT SF®M5x10-K	2 Nm (1.5 lbf ft)
Screw, magnetic switch on handlebar	M3	0.8 Nm (0.59 lbf ft)
Spoke nipple	M3.5	3 Nm (2.2 lbf ft)
Screw, fixed grip	M4	5 Nm (3.7 lbf ft)
Screw, throttle grip	M4	3 Nm (2.2 lbf ft)
Remaining nuts, chassis	M5	5 Nm (3.7 lbf ft)
Remaining screws, chassis	M5	5 Nm (3.7 lbf ft)
Screw, brake linings	M5	8 Nm (5.9 lbf ft)
Nut, push rod ball joint on foot brake cylinder	M6	10 Nm (7.4 lbf ft)

Nut, push rod, foot brake lever	M6	6 Nm (4.4 lbf ft)	
Rear fairing screw	M6	8 Nm (5.9 lbf ft)	
Remaining nuts, chassis	M6	10 Nm (7.4 lbf ft)	
Remaining screws, chassis	M6	10 Nm (7.4 lbf ft)	
Screw, chain sliding guard	M6	3 Nm (2.2 lbf ft)	
Screw, fender	M6	6 Nm (4.4 lbf ft)	
Screw, fork stub	M6	10 Nm (7.4 lbf ft)	
Screw, front brake disc	M6	14 Nm (10.3 lbf ft)	Loctite®243™
Screw, rear brake caliper	M6x16	10 Nm (7.4 lbf ft)	Loctite®243™
Screw, rear brake caliper	M6x40	10 Nm (7.4 lbf ft)	Loctite®243™
Screw, rear brake disc	M6	14 Nm (10.3 lbf ft)	Loctite®243™
Screw, splash protector	M6	8 Nm (5.9 lbf ft)	
Screw, start number plate	M6	4 Nm (3 lbf ft)	
Screw, subframe connection	M6	10 Nm (7.4 lbf ft)	
Threaded adapter for front fairing	M6	8 Nm (5.9 lbf ft)	
Nut, foot brake lever	M8	22 Nm (16.2 lbf ft)	
Nut, rim lock	M8	10 Nm (7.4 lbf ft)	
Remaining nuts, chassis	M8	25 Nm (18.4 lbf ft)	
Remaining screws, chassis	M8	25 Nm (18.4 lbf ft)	
Screw, bottom triple clamp	M8	15 Nm (11.1 lbf ft)	
Screw, chain sliding piece	M8	15 Nm (11.1 lbf ft)	
Screw, engine bracket	M8	25 Nm (18.4 lbf ft)	Loctite®243™
Screw, front brake caliper	M8x60	20 Nm (14.8 lbf ft)	Loctite®243™
Screw, front brake caliper	M8x40	20 Nm (14.8 lbf ft)	Loctite®243™
Screw, handlebar clamp	M8	20 Nm (14.8 lbf ft)	
Screw, Powerpack LV front	M8x25	20 Nm (14.8 lbf ft)	
Screw, Powerpack LV rear	M8x50	20 Nm (14.8 lbf ft)	Loctite®243™
Screw, rear sprocket	M8	25 Nm (18.4 lbf ft)	Loctite®243™
Screw, steering stem	M8	20 Nm (14.8 lbf ft)	
Screw, subframe	M8	30 Nm (22.1 lbf ft)	Loctite®243™
Screw, top triple clamp	M8	20 Nm (14.8 lbf ft)	
Remaining nuts, chassis	M10	45 Nm (33.2 lbf ft)	
Remaining screws, chassis	M10	45 Nm (33.2 lbf ft)	
Screw, bottom shock absorber	M10	45 Nm (33.2 lbf ft)	Loctite®243™
Screw, front wheel spindle	M10	40 Nm (29.5 lbf ft)	Loctite®243™

Screw, handlebar support	M10	40 Nm (29.5 lbf ft) Loctite®243™
Screw, top shock absorber	M10	45 Nm (33.2 lbf ft) Loctite®243™
Nut, rear wheel spindle	M12x1	40 Nm (29.5 lbf ft)
Nut, swingarm pivot	M12x1	45 Nm (33.2 lbf ft)
Nut, steering head	M20x1.5	10 Nm (7.4 lbf ft)

Brake fluid DOT 4 / DOT 5.1

Standard/classification

- DOT

Guideline

- Use only brake fluid that complies with the specified standard (see specifications on the container) and that exhibits the corresponding properties.

Recommended supplier**Castrol**

- REACT PERFORMANCE DOT 4

MOTOREX®

- Brake Fluid DOT 5.1

Fork oil (SAE 4) (48601166S1)

Standard/classification

- SAE (📖 p. 100) (SAE 4)

Guideline

- Use only oils that comply with the specified standards (see specifications on the container) and that exhibit the corresponding properties.

Shock absorber fluid (SAE 2.5) (50180751S1)

Standard/classification

- SAE (📖 p. 100) (SAE 2.5)

Guideline

- Use only oils that comply with the specified standards (see specifications on the container) and that exhibit the corresponding properties.

Chain cleaner

Recommended supplier

MOTOREX®

- Chain Clean

High viscosity grease

Recommended supplier

SKF®

- LGHB 2

Long-life grease

Recommended supplier

MOTOREX®

- Bike Grease 2000

Motorcycle cleaner

Recommended supplier

MOTOREX®

- Moto Clean

Off-road chain spray

Recommended supplier

MOTOREX®

- Chainlube Offroad

Preserving materials for paints, metal and rubber

Recommended supplier

MOTOREX®

- Moto Protect

Special cleaner for glossy and matte paint finishes, metal and plastic surfaces

Recommended supplier

MOTOREX®

- Quick Cleaner

Special grease (00062010053)

Recommended supplier

Klüber Lubrication®

- KLÜBERFOOD NH1 34-401

Universal oil spray

Recommended supplier

MOTOREX®

- Joker 440 Synthetic

SAE

The SAE viscosity classes were defined by the Society of Automotive Engineers and are used for classifying oils according to their viscosity. The viscosity describes only one property of oil and says nothing about quality.

BIN	Battery identification number	Serial number of the Powerpack HV; this is linked to the vehicle's identification number
-----	-------------------------------	--

26 LIST OF ABBREVIATIONS

Art. no.	Article number
ca.	circa
cf.	compare
e.g.	for example
etc.	et cetera
i.a.	inter alia
no.	number
poss.	possibly

27.1 Yellow and orange symbols

Yellow and orange symbols indicate an error condition that requires prompt intervention. Active driving aids are also represented by yellow or orange symbols.



The malfunction indicator lamp flashes – A fault is present in the vehicle electronic system.

A		F	
Accessories	10	Fall	8
Accident	8	Figures	10
Air suspension	30	Fire hazard	9
Auxiliary substances	10	Foot brake lever	17
B		basic position, adjusting	70
Basic chassis setting		free travel, adjusting	69
rider's weight, checking with	30	free travel, checking	69
Battery charger		Fork legs	
overview	82	air pressure, adjusting	37
positioning	82	basic setting, checking	36
Brake discs		bleeding	45
checking	63	installing	47
Brake fluid		removing	47
of front brake, adding	65	Fork part number	14
of rear brake, adding	71	Fork protector	
Brake fluid level		installing	47
of front brake, checking	64	removing	46
of the rear brake, checking	71	Frame	
Brake linings		checking	60
front brake, checking	66	Front fender	
of front brake, changing	66	installing	54
of rear brake, changing	73	removing	53
of the rear brake, checking	72	Front wheel	
C		installing	76
Care	88-89	removing	76
Chain		Fuel, oils, etc.	10
checking	58	H	
cleaning	56	Hand brake lever	16
Chain guide		basic position, adjusting	62
adjusting	60	checking play	62
checking	58	play, adjusting	62
Chain tension		Handlebar position	38
adjusting	57	adjusting	39
checking	57	High-speed compression damping	
Charging	83	shock absorber, adjusting	32
Charging level indicator	20	I	
Cleaning	88-89	Implied warranty	10
Cooling	87	Intended use	6
Customer service	10	L	
D		Link fork	
Diagnostics connector	18	checking	61
Dust boots		Lower triple clamp	
cleaning	46	installing	49
E		removing	48
Environment	8	Low-speed compression damping	
		shock absorber, adjusting	31

M		Rechargeable lithium-ion battery	
Magnetic switch		battery identification number (BIN)	15
on handlebar	16	charging	83
under the seat	17	work	8
Malfunction indicator lamp	20	Recuperation	26
Manufacturer warranty	10	Ride mode button	19
Misuse	6	Ride mode display	20
Motor		Riding sag	
work	8	adjusting	36
Motor number	14	Rubber grip	
Motor sprocket		checking	61
checking	58	S	
Motorcycle		Safe operation	7
cleaning	88	Seat	
lift stand, raising with	45	mounting	55
lift stand, removing from	45	removing	55
Multifunctional element	19	Seat height	
Overview	19	adjusting on the fork	41
O		adjusting on the frame	42
On/Off button	16	adjusting on the shock absorber	40
Operation		adjustment options	40
at low temperatures	11	Service	10
Owner's Manual	9	Service schedule	28-29
P		Shock absorber	
Plug-in stand	18	installing	54
Power reduction	21	removing	54
Power supply	11	riding sag, checking	34
Powerpack LV		spring preload, adjusting	35
battery identification number (BIN)	15	static sag, checking	34
charging	83	Shock absorber article number	15
work	8	Spare parts	10
Preparing for use		Spoke tension	
advice on preparing for first use	22	checking	80
after storage	90	Start number plate	
checks and maintenance measures when		installing	53
preparing for use	24	removing	53
Protective clothing	8	Starting	24
R		Steering head bearing	
Rear sprocket		lubricating	52
checking	58	Steering head bearing play	
Rear wheel		adjusting	52
installing	78	checking	51
removing	77	Storage	90
Rebound damping		T	
fork, adjusting	38	Technical data	
shock absorber, adjusting	32	chassis	93
		chassis tightening torques	95

electrical system	94
engine	93
fork	94
shock absorber	95
tires	94
Throttle grip	16
Tire condition	
checking	79
Tire pressure	
checking	80
Transportation	27
Troubleshooting	91-92
Type label	14
U	
Use definition	6
V	
Vehicle	
work	8
Vehicle identification number	14
View of vehicle	
front left	12
rear right	13



3402438en

05/2020



Husqvarna Motorcycles GmbH
Stallhofnerstraße 3 | 5230 Mattighofen | Austria
www.husqvarna-motorcycles.com



Photo: Mitterbauer/KISKA,
Husqvarna Motorcycles GmbH