

# OWNER'S MANUAL 2021



TC 50

TC 50 MINI

Art. no. 3402435en



# DEAR HUSQVARNA MOTORCYCLES CUSTOMER

Congratulations on your decision to purchase a Husqvarna motorcycle. You are now the owner of a state-of-the-art sports vehicle that will continue to give you and your child pleasure for a long time if you maintain it properly.

We hope your child has many safe and enjoyable rides!

Enter the serial numbers of your vehicle below.

Vehicle identification number (📖 p. 13)	Dealer's stamp
Engine number (📖 p. 13)	

The Owner's Manual contained the latest information for this model series at the time of going to print. However, minor differences due to further developments in design cannot be ruled out completely.

All specifications contained herein are non-binding. Husqvarna Motorcycles GmbH specifically reserves the right to modify or delete technical specifications, prices, colors, forms, materials, services, designs, equipment, etc., without prior notice and without specifying reasons, to adapt these to local conditions, as well as to stop production of a particular model without prior notice. Husqvarna Motorcycles accepts no liability for delivery options, deviations from illustrations and descriptions, as well as misprints and other errors. The models portrayed partly contain special equipment that does not belong to the regular scope of supply.

© 2020 Husqvarna Motorcycles GmbH, Mattighofen Austria

All rights reserved

Reproduction, even in part, as well as copying of all kinds, is permitted only with the express written permission of the copyright owner.



REG.NO. 12 100 6061

ISO 9001(12 100 6061)

Husqvarna Motorcycles applies quality assurance processes that lead to the highest possible product quality as defined in the ISO 9001 international quality management standard.

Issued by: TÜV-Management Service

Husqvarna Motorcycles GmbH  
Stallhofnerstraße 3  
5230 Mattighofen, Austria

This document is valid for the following models:

TC 50 (F2001U4)





TC 50 MINI (F2001U5)



3402435en















05/2020

# TABLE OF CONTENTS

1	MEANS OF REPRESENTATION.....	5	7	PREPARING FOR USE.....	19
	1.1 Symbols used .....	5	7.1	Advice on preparing for first use.....	19
	1.2 Formats used .....	5	7.2	Running in the engine .....	21
2	SAFETY ADVICE .....	6	8	RIDING INSTRUCTIONS .....	22
	2.1 Use definition – intended use .....	6	8.1	Checks and maintenance measures when preparing for use.....	22
	2.2 Misuse.....	6	8.2	Starting the vehicle .....	22
	2.3 Safety advice .....	6	8.3	Starting off .....	23
	2.4 Degrees of risk and symbols .....	6	8.4	Riding.....	23
	2.5 Tampering warning .....	7	8.5	Applying the brakes .....	24
	2.6 Safe operation.....	7	8.6	Stopping, parking .....	24
	2.7 Protective clothing .....	8	8.7	Transporting.....	25
	2.8 Work rules.....	8	8.8	Refueling.....	25
	2.9 Environment.....	8	8.9	Filling up with oil (TC 50 MINI) .....	26
	2.10 Owner's Manual.....	8	9	SERVICE SCHEDULE.....	27
3	IMPORTANT NOTES.....	9	9.1	Additional information.....	27
	3.1 Manufacturer warranty, implied warranty .....	9	9.2	Required work.....	27
	3.2 Fuel, auxiliary substances.....	9	9.3	Recommended work.....	28
	3.3 Spare parts, accessories .....	9	10	TUNING THE CHASSIS.....	29
	3.4 Service .....	9	10.1	Checking the basic chassis setting with rider's weight.....	29
	3.5 Figures .....	9	10.2	Air suspension XACT 5235 (TC 50).....	29
	3.6 Customer service.....	10	10.3	Compression damping of the shock absorber (TC 50) .....	30
4	VIEW OF VEHICLE .....	11	10.4	Adjusting the low-speed compression damping of the shock absorber (TC 50) .....	30
	4.1 View of vehicle, front left (example) ....	11	10.5	Adjusting the high-speed compression damping of the shock absorber (TC 50) .....	31
	4.2 View of vehicle, rear right (example).....	12	10.6	Adjusting the rebound damping of the shock absorber .....	31
5	SERIAL NUMBERS.....	13	10.7	Measuring the rear wheel dimension unloaded .....	33
	5.1 Vehicle identification number.....	13	10.8	Checking the static sag of the shock absorber.....	33
	5.2 Type label.....	13	10.9	Checking the riding sag of the shock absorber.....	34
	5.3 Engine number.....	13	10.10	Adjusting the spring preload of the shock absorber  .....	34
	5.4 Fork part number .....	14	10.11	Adjusting the riding sag  .....	36
	5.5 Shock absorber article number .....	14	10.12	Checking the basic setting of the fork.....	37
6	CONTROLS .....	15	10.13	Adjusting the fork air pressure (TC 50).....	37
	6.1 Hand brake lever.....	15	10.14	Adjusting the rebound damping of the fork (TC 50) .....	38
	6.2 Throttle grip.....	15	10.15	Handlebar position.....	39
	6.3 Switch-off button .....	15	10.16	Adjusting the handlebar position  .....	39
	6.4 Opening the fuel tank filler cap.....	15	10.17	Adjusting the seat height  .....	40
	6.5 Closing the fuel tank filler cap.....	16			
	6.6 Opening oil tank cap (TC 50 MINI).....	16			
	6.7 Closing oil tank cap (TC 50 MINI) .....	17			
	6.8 Fuel tap .....	17			
	6.9 Choke (TC 50).....	17			
	6.10 Choke (TC 50 MINI) .....	17			
	6.11 Kick starter lever .....	18			
	6.12 Foot brake lever .....	18			
	6.13 Plug-in stand.....	18			
	6.14 Service hour counter.....	18			

11	SERVICE WORK ON THE CHASSIS .....	41	11.40	Checking the chain tension .....	67
11.1	Raising the motorcycle with a lift stand .....	41	11.41	Adjusting the chain tension.....	68
11.2	Removing the motorcycle from the lift stand .....	41	11.42	Checking the chain, rear sprocket, engine sprocket, and chain guide.....	69
11.3	Bleeding the fork legs .....	41	11.43	Adjusting the chain guide 🛠️ .....	73
11.4	Cleaning the dust boots of the fork legs .....	42	11.44	Checking the frame 🛠️.....	73
11.5	Removing the fork protector .....	43	11.45	Checking the link fork 🛠️ .....	73
11.6	Installing the fork protector.....	43	11.46	Checking the throttle cable routing ....	74
11.7	Removing fork legs 🛠️ .....	44	11.47	Checking the rubber grip .....	75
11.8	Installing the fork legs 🛠️.....	44	11.48	Additionally securing the rubber grip.....	75
11.9	Removing the lower triple clamp 🛠️ ....	46	12	BRAKE SYSTEM .....	76
11.10	Installing the lower triple clamp 🛠️ .....	47	12.1	Checking play of handbrake lever .....	76
11.11	Checking the steering head bearing play .....	50	12.2	Adjusting the play of the hand brake lever .....	76
11.12	Adjusting the steering head bearing play 🛠️.....	50	12.3	Adjusting the basic position of the hand brake lever .....	76
11.13	Lubricating the steering head bearing 🛠️.....	51	12.4	Checking the brake discs .....	77
11.14	Removing the fuel tank 🛠️ .....	52	12.5	Checking the front brake fluid level ....	78
11.15	Installing the fuel tank 🛠️.....	53	12.6	Adding the front brake fluid 🛠️.....	79
11.16	Removing the start number plate .....	54	12.7	Checking the front brake linings .....	80
11.17	Installing the start number plate .....	54	12.8	Changing the brake linings of the front brake 🛠️.....	80
11.18	Removing front fender .....	54	12.9	Checking the free travel of the foot brake lever .....	84
11.19	Installing front fender .....	55	12.10	Adjusting the free travel of the foot brake lever 🛠️ .....	84
11.20	Removing the right side cover .....	55	12.11	Adjusting the basic position of the foot brake lever 🛠️.....	85
11.21	Installing the right side cover .....	56	12.12	Checking the rear brake fluid level ....	85
11.22	Preparing the right side cover for securing 🛠️ .....	57	12.13	Adding rear brake fluid 🛠️.....	86
11.23	Removing the left side cover .....	57	12.14	Checking the brake linings of the rear brake.....	87
11.24	Installing the left side cover .....	58	12.15	Changing the brake linings of the rear brake 🛠️.....	88
11.25	Preparing the left side cover for securing 🛠️ .....	59	13	WHEELS, TIRES .....	93
11.26	Removing the shock absorber 🛠️.....	59	13.1	Removing the front wheel 🛠️.....	93
11.27	Installing the shock absorber 🛠️.....	60	13.2	Installing the front wheel 🛠️.....	93
11.28	Removing the seat .....	61	13.3	Removing the rear wheel 🛠️ .....	94
11.29	Mounting the seat .....	61	13.4	Installing the rear wheel 🛠️.....	96
11.30	Removing the air filter 🛠️.....	62	13.5	Checking the tire condition.....	97
11.31	Installing the air filter 🛠️.....	62	13.6	Checking tire pressure .....	98
11.32	Cleaning the air filter and air filter box 🛠️.....	63	13.7	Checking spoke tension .....	99
11.33	Removing the main silencer.....	63	14	COOLING SYSTEM .....	100
11.34	Installing the main silencer.....	64	14.1	Cooling system .....	100
11.35	Changing the glass fiber yarn filling of the main silencer 🛠️.....	64	14.2	Checking the antifreeze and coolant level.....	100
11.36	Removing the engine sprocket cover .....	65	14.3	Checking the coolant level.....	101
11.37	Installing the engine sprocket cover .....	65	14.4	Draining the coolant 🛠️.....	101
11.38	Checking the chain for dirt.....	66	14.5	Refilling with coolant 🛠️.....	102
11.39	Cleaning the chain .....	66			

# TABLE OF CONTENTS

14.6	Changing the coolant 	103	21.5	Chassis .....	132
15	TUNING THE ENGINE.....	105	21.6	Tires .....	133
15.1	Checking the throttle cable play .....	105	21.7	Fork.....	133
15.2	Adjusting the throttle cable play  .....	105	21.7.1	TC 50.....	133
15.3	Carburetor – idle setting (TC 50).....	106	21.7.2	TC 50 MINI .....	133
15.4	Carburetor – idle setting (TC 50 MINI).....	106	21.8	Shock absorber .....	134
15.5	Carburetor - adjusting the idle speed  (TC 50).....	107	21.8.1	TC 50.....	134
15.6	Carburetor – adjusting the idle speed  (TC 50 MINI) .....	108	21.8.2	TC 50 MINI .....	134
15.7	Checking the clutch setting  .....	109	21.9	Chassis tightening torques .....	135
15.8	Removing the clutch cover  .....	109	22	SUBSTANCES.....	137
15.9	Adjusting the clutch  .....	110	23	AUXILIARY SUBSTANCES.....	139
15.10	Installing the clutch cover  .....	111	24	STANDARDS .....	141
16	SERVICE WORK ON THE ENGINE .....	112	25	LIST OF ABBREVIATIONS .....	142
16.1	Checking oil level (TC 50 MINI).....	112	INDEX .....		143
16.2	Bleeding the oil pump  (TC 50 MINI).....	112			
16.3	Checking the gear oil level.....	113			
16.4	Changing the gear oil  .....	114			
16.5	Adding the gear oil  .....	115			
17	CARBURETOR .....	117			
17.1	Removing the carburetor  (TC 50 MINI).....	117			
17.2	Removing the carburetor  (TC 50).....	118			
17.3	Installing the carburetor  (TC 50 MINI).....	120			
17.4	Installing the carburetor  (TC 50)....	121			
18	CLEANING, CARE .....	123			
18.1	Cleaning the motorcycle .....	123			
19	STORAGE.....	125			
19.1	Storage .....	125			
19.2	Preparing for use after storage .....	126			
20	TROUBLESHOOTING .....	127			
21	TECHNICAL DATA .....	130			
21.1	Engine .....	130			
21.2	Engine tightening torques.....	130			
21.3	Carburetor with carburetor tuning ....	131			
21.3.1	TC 50.....	131			
21.3.2	TC 50 MINI .....	131			
21.4	Capacities .....	132			
21.4.1	Gear oil .....	132			
21.4.2	Coolant.....	132			
21.4.3	Fuel.....	132			

## 1.1 Symbols used

The meaning of specific symbols is described below.



Indicates an expected reaction (e.g. of a work step or a function).



Indicates an unexpected reaction (e.g. of a work step or a function).



All work marked with this symbol requires specialist knowledge and technical understanding. In the interest of the safety of your child, have these jobs performed in an authorized Husqvarna Motorcycles workshop. There, your motorcycle will be optimally cared for by specially trained experts using the specialist tools required.



Indicates a page reference (more information is provided on the specified page).



Indicates information with more details or tips.



Indicates the result of a testing step.



Indicates the end of an activity, including potential rework.

## 1.2 Formats used

The typographical formats used in this document are explained below.

**Proprietary name**

Indicates a proprietary name.

**Name<sup>®</sup>**

Indicates a protected name.

**Brand<sup>™</sup>**

Indicates a brand available on the open market.

**Underlined terms**

Refer to technical details of the vehicle or indicate technical terms, which are explained in the glossary.

## 2 SAFETY ADVICE

### 2.1 Use definition – intended use

This vehicle has been designed and built to withstand the normal stresses and strains of racing. This vehicle complies with the currently valid regulations and categories of the top international motorsports organizations.



#### Info

Only operate this vehicle in closed-off areas remote from public road traffic.

---

### 2.2 Misuse

The vehicle must only be used as intended.

Dangers can arise for people, property and the environment through use not as intended.

Any use of the vehicle beyond the intended and defined use constitutes misuse.

Misuse also includes the use of operating and auxiliary fluids which do not meet the required specification for the respective use.

### 2.3 Safety advice

A number of safety instructions need to be followed to operate the product described safely. Therefore read this instruction and all further instructions included carefully. The safety instructions are highlighted in the text and are referred to at the relevant passages.



#### Info

Various information and warning labels are attached in prominent locations on the product described. Do not remove any information or warning labels. If they are missing, you or others may not recognize dangers and may therefore be injured.

---

### 2.4 Degrees of risk and symbols



#### Danger

Identifies a danger that will immediately and invariably lead to fatal or serious permanent injury if the appropriate measures are not taken.



#### Warning

Identifies a danger that is likely to lead to fatal or serious injury if the appropriate measures are not taken.



#### Caution

Identifies a danger that may lead to minor injuries if the appropriate measures are not taken.

#### Note

Identifies a danger that will lead to considerable machine and material damage if the appropriate measures are not taken.



#### Note

Indicates a danger that will lead to environmental damage if the appropriate measures are not taken.

---



## 2.5 Tampering warning

Tampering with the noise control system is prohibited. Federal law prohibits the following acts or the causing thereof:

- 1 The removal or rendering inoperative by any person other than for purposes of servicing, repair, or replacement, of any device or element of design incorporated into any new vehicle for the purpose of noise control prior to its sale or delivery to the ultimate purchaser or while it is in use, or
- 2 the use of the vehicle after such device or element of design has been removed or rendered inoperative by any person.

Among those acts presumed to constitute tampering are the acts listed below:

- 1 Removal or puncturing of the main silencers, baffles, header pipes or any other components which conduct exhaust gases.
- 2 Removal or puncturing of parts of the intake system.
- 3 Lack of proper maintenance.
- 4 Replacing moving parts of the vehicle, or parts of the exhaust system or intake system, with parts other than those specified by the manufacturer.

## 2.6 Safe operation



### Danger

**Danger of accidents** A rider who is not fit to ride poses a danger to him or herself and others.

- Do not operate the vehicle if you are not fit to ride due to alcohol, drugs or medication.
- Do not operate the vehicle if you are physically or mentally impaired.



### Danger

**Danger of poisoning** Exhaust gases are toxic and inhaling them may result in unconsciousness and death.

- Always make sure there is sufficient ventilation when running the engine.
- Use effective exhaust extraction when starting or running the engine in an enclosed space.



### Warning

**Danger of burns** Some vehicle components become very hot when the vehicle is operated.

- Do not touch any parts such as the exhaust system, radiator, engine, shock absorber, or brake system before the vehicle parts have cooled down.
- Let the vehicle parts cool down before you perform any work on the vehicle.

Only operate the vehicle when it is in perfect technical condition, in accordance with its intended use, and in a safe and environmentally compatible manner.

The vehicle should only be used by trained persons.

Have malfunctions that impair safety promptly eliminated by an authorized Husqvarna Motorcycles workshop.

Adhere to the information and warning labels on the vehicle.

### 2.7 Protective clothing



#### Warning

**Risk of injury** Missing or poor protective clothing presents an increased safety risk.

- Ensure your child wears appropriate protective clothing such as helmet, boots, gloves as well as trousers and a jacket with protectors on all rides.
- Always use protective clothing for your child that is in good condition and meets the legal requirements.
- When you ride a motorcycle, set an example for your child and wear suitable protective clothing.

In the interest of your child's safety, Husqvarna Motorcycles recommends that only operating the vehicle while wearing protective clothing.

### 2.8 Work rules

Unless specified otherwise, the ignition must be turned off during all work (models with ignition lock, models with remote key) or the engine must be at a standstill (models without ignition lock or remote key).

Special tools are necessary for certain tasks. The tools are not a component of the vehicle, but can be ordered using the number in parentheses. Example: bearing puller (15112017000)

During assembly, use new parts to replace parts which cannot be reused (e.g. self-locking screws and nuts, expansion screws, seals, sealing rings, O-rings, pins, and lock washers).

In the case of certain screws, a screw adhesive (e.g. **Loctite**<sup>®</sup>) is required. Observe the manufacturer's instructions.

If thread locker (e.g., **Precote**<sup>®</sup>) has already been applied to a new part, do not apply any additional thread locker.

After disassembly, clean the parts that are to be reused and check them for damage and wear. Change damaged or worn parts.

After completing a repair or service work, check the operating safety of the vehicle.

### 2.9 Environment

If you use your motorcycle responsibly, you can ensure that problems and conflicts do not occur. To protect the future of the motorcycle sport, make sure that you use your motorcycle legally, be environmentally aware, and respect the rights of others.

When disposing of used oil, other operating and auxiliary fluids, and used components, comply with the laws and regulations of the respective country.

Because motorcycles are not subject to the EU regulations governing the disposal of used vehicles, there are no legal regulations that pertain to the disposal of an end-of-life motorcycle. Your authorized Husqvarna Motorcycles dealer will be glad to advise you.

### 2.10 Owner's Manual

It is important that you read this Owner's Manual carefully and completely before your child makes his or her first trip. The Owner's Manual contains useful information and many tips for you and your child on how to operate, handle, and service your motorcycle. This is the only way for you to find out how to ideally tune the vehicle and how to protect your child from injury.

Keep the Owner's Manual in an accessible place to enable you to refer to it as needed.

If you would like to know more about the vehicle or have questions on the material you read, please contact an authorized Husqvarna Motorcycles dealer.

The Owner's Manual is an important component of the vehicle and must be handed over to the new owner if the vehicle is sold.

The Owner's Manual is also available for download from your authorized Husqvarna Motorcycles dealer and on the Husqvarna Motorcycles website.

International Husqvarna Motorcycles website: [www.husqvarna-motorcycles.com](http://www.husqvarna-motorcycles.com)

## 3.1 Manufacturer warranty, implied warranty

The work prescribed in the service schedule must only be carried out in an authorized Husqvarna Motorcycles workshop and confirmed in the **Husqvarna Motorcycles Dealer.net**, as otherwise all warranty claims will be void. Damage or secondary damage caused by tampering with and/or conversions on the vehicle are not covered by the manufacturer warranty.

## 3.2 Fuel, auxiliary substances



### Note

**Environmental hazard** Improper handling of fuel is a danger to the environment.

- Do not allow fuel to enter the groundwater, the soil, or the sewage system.

Use fuels and auxiliary substances in accordance with the Owner's Manual and specification.

## 3.3 Spare parts, accessories

For the safety of your child, only use spare parts and accessory products that are approved and/or recommended by Husqvarna Motorcycles and have them installed by an authorized Husqvarna Motorcycles workshop. Husqvarna Motorcycles accepts no liability for other products and any resulting damage or loss. Certain spare parts and accessory products are specified in parentheses in the descriptions. Your authorized Husqvarna Motorcycles dealer will be glad to advise you.

The current Husqvarna Motorcycles accessories for your vehicle can be found on the Husqvarna Motorcycles website.

International Husqvarna Motorcycles website: [www.husqvarna-motorcycles.com](http://www.husqvarna-motorcycles.com)

## 3.4 Service

A prerequisite for perfect operation and prevention of premature wear is that the service, care, and tuning work on the engine and chassis is properly carried out as described in the Owner's Manual. An incorrect suspension setting can lead to damage and breakage of chassis components.

Use of the vehicle under difficult conditions, such as on sand or on wet and muddy surfaces, can result in significantly increased wear of components, such as the drive train, brake system, or suspension components. For this reason, it may be necessary to inspect or replace parts before the next scheduled service.

It is imperative that you adhere to the stipulated run-in times and service intervals. If you observe these exactly, you will ensure a much longer service life for your motorcycle.

The relevant mileage or time interval is whichever occurs first.

## 3.5 Figures

The figures contained in the manual may depict special equipment.

In the interest of clarity, some components may be shown disassembled or may not be shown at all. It is not always necessary to disassemble the component to perform the activity in question. Please follow the instructions in the text.

## 3 IMPORTANT NOTES

### 3.6 Customer service

Your authorized Husqvarna Motorcycles dealer will be happy to answer any questions you may have regarding your vehicle and Husqvarna Motorcycles.

A list of authorized Husqvarna Motorcycles dealers can be found on the Husqvarna Motorcycles website. International Husqvarna Motorcycles website: [www.husqvarna-motorcycles.com](http://www.husqvarna-motorcycles.com)

## 4.1 View of vehicle, front left (example)



- ① Fuel tank filler cap
- ② Quick release of seat
- ③ Chain guide
- ④ Plug-in stand (📖 p. 18)
- ⑤ Choke
- ⑥ Fuel tap (📖 p. 17)

## 4 VIEW OF VEHICLE

### 4.2 View of vehicle, rear right (example)



- ❶ Switch-off button (📖 p. 15)
- ❷ Throttle grip (📖 p. 15)
- ❸ Hand brake lever (📖 p. 15)
- ❹ Vehicle identification number (📖 p. 13)
- ❺ Kick starter lever (📖 p. 18)
- ❻ Foot brake lever (📖 p. 18)
- ❼ Level viewer for brake fluid, rear

## 5.1 Vehicle identification number

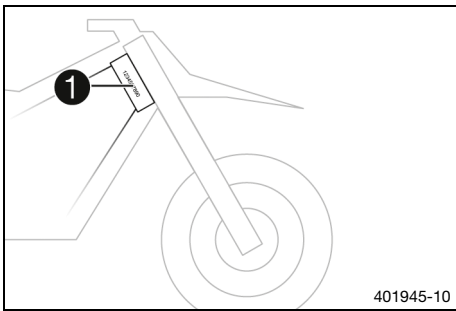

The vehicle identification number **1** is stamped on the right side of the steering head.

## 5.2 Type label

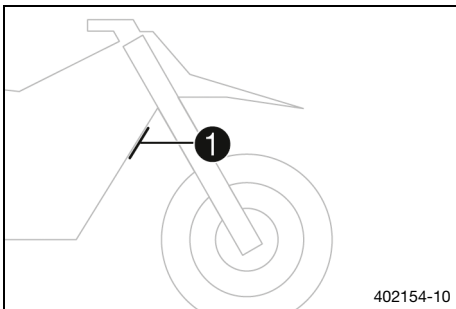

**(TC 50)**

The type label **1** is located on the front frame tube.

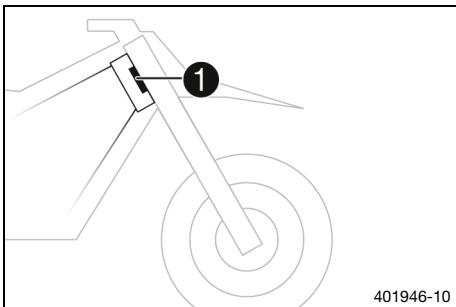

**(TC 50 MINI)**

Type label **1** is fixed to the front of the steering head.

## 5.3 Engine number

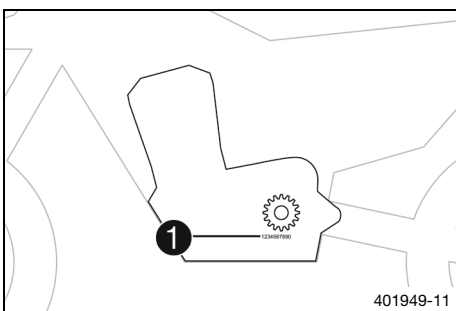

The engine number **1** is located on the left side of the engine under the engine sprocket.

# 5 SERIAL NUMBERS

## 5.4 Fork part number

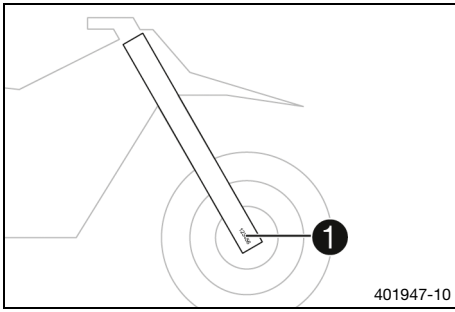

The fork part number ❶ is stamped on the outside of the axle clamp.

## 5.5 Shock absorber article number

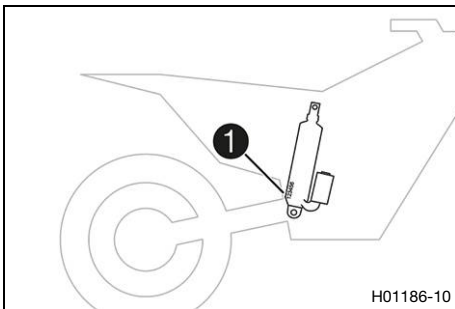

**(TC 50)**

The shock absorber article number ❶ is stamped on the bottom of the shock absorber toward the right-hand side.

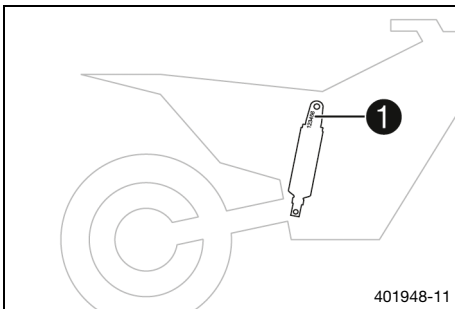

**(TC 50 MINI)**

The shock absorber article number ❶ is stamped on the top of the shock absorber toward the rear.



## 6.1 Hand brake lever

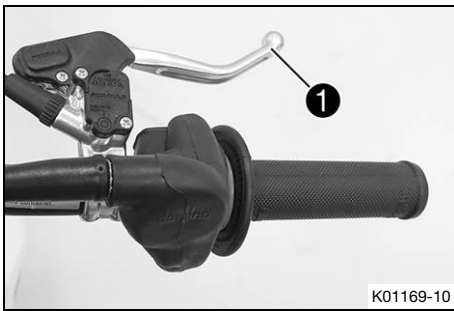

Hand brake lever ❶ is fitted on the right side of the handlebar. The hand brake lever is used to activate the front brake.

## 6.2 Throttle grip

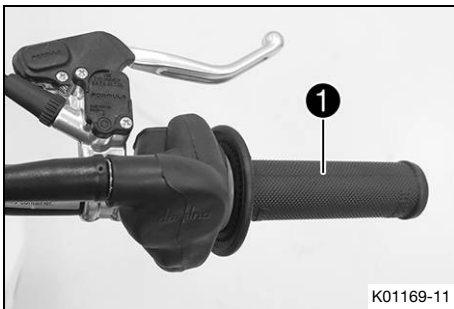

Throttle grip ❶ is fitted on the right side of the handlebar.

## 6.3 Switch-off button



Switch-off button ❶ is fitted on the left side of the handlebar.

### Possible states

- The switch-off button ☒ is in the basic position – In this position, the ignition circuit is closed and the engine can be started.
- The switch-off button ☒ is pressed – In this position, the ignition circuit is interrupted, a running engine stops, and a non-running engine will not start.

## 6.4 Opening the fuel tank filler cap



### Danger

**Fire hazard** Fuel is highly flammable.

The fuel in the fuel tank expands when warm and can escape if overfilled.

- Do not fuel the vehicle in the vicinity of open flames or lit cigarettes.
- Switch off the engine for refueling.
- Make sure that no fuel is spilled; particularly not on hot parts of the vehicle.
- If any fuel is spilled, wipe it off immediately.
- Observe the specifications for refueling.



## Warning

**Danger of poisoning** Fuel is poisonous and a health hazard.

- Avoid skin, eye and clothing contact with fuel.
- Immediately consult a doctor if you swallow fuel.
- Do not inhale fuel vapors.
- In case of skin contact, rinse the affected area with plenty of water.
- Rinse the eyes thoroughly with water, and consult a doctor in case of fuel contact with the eyes.
- Change your clothing in case of fuel spills on them.
- Keep fuels correctly in a suitable canister, and out of the reach of children.



## Note

**Environmental hazard** Improper handling of fuel is a danger to the environment.

- Do not allow fuel to enter the groundwater, the soil, or the sewage system.

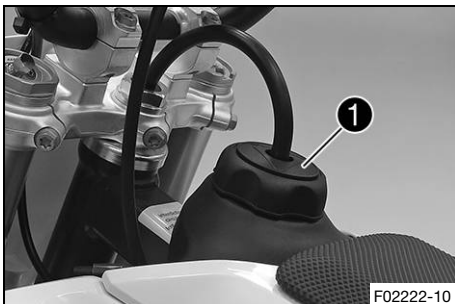

- Turn fuel tank filler cap **1** counterclockwise and lift it off.

## 6.5 Closing the fuel tank filler cap

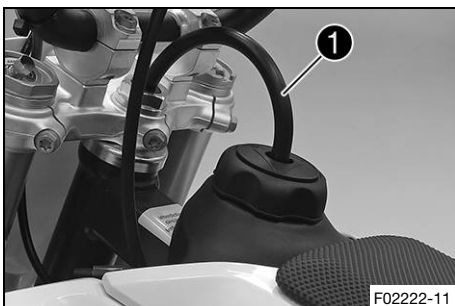

- Mount the fuel tank filler cap and turn it clockwise until the fuel tank is tightly closed.

### **i** Info

Route fuel tank breather hose **1** without kinks.

## 6.6 Opening oil tank cap (TC 50 MINI)

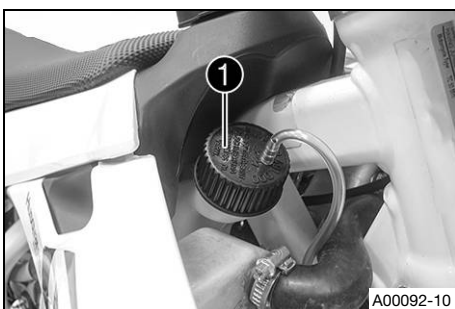

- Turn the oil tank cap **1** counterclockwise and pull it up.

## 6.7 Closing oil tank cap (TC 50 MINI)

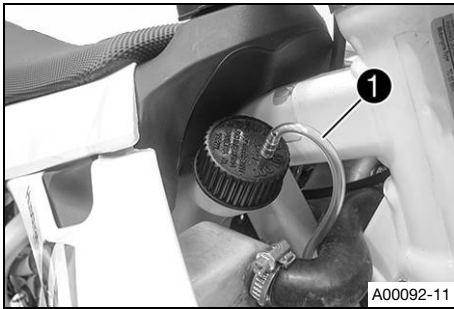

- Put the oil tank cap on and turn it clockwise.



### Info

Run the oil tank breather hose ① without kinks.

## 6.8 Fuel tap

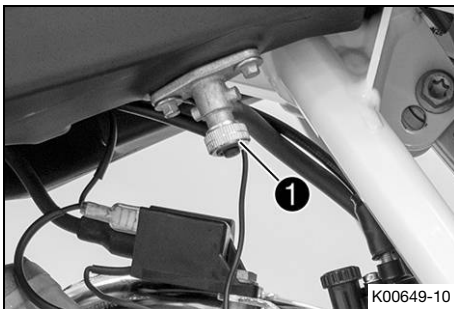

Fuel tap ① is on the left of the fuel tank.

### Possible states

- Fuel tap is closed – The knurled screw is turned all the way clockwise. Fuel cannot flow out of the fuel tank.
- Fuel tap is open – The knurled screw is turned all the way counterclockwise. Fuel can flow out of the fuel tank.

## 6.9 Choke (TC 50)

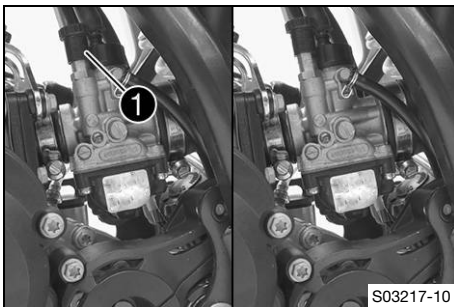

Choke ① is fitted on the left side of the carburetor. Activating the choke function frees a drill hole in the carburetor through which the engine can draw extra fuel. This results in a richer fuel-air mixture, which is needed for a cold start.



### Info

If the engine is warm, the choke function must be deactivated.

### Possible states

- Choke function activated – The choke lever is pulled out to the stop.
- Choke function deactivated – The choke lever is pushed in to the stop.

## 6.10 Choke (TC 50 MINI)

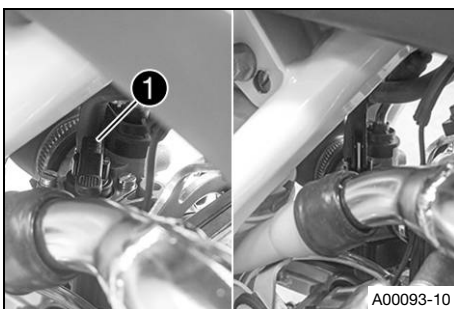

The choke lever ① is fitted on the right of the carburetor. Activating the choke function frees a drill hole in the carburetor through which the engine can draw extra fuel. This results in a richer fuel-air mixture, which is needed for a cold start.



### Info

If the engine is warm, the choke function must be deactivated.

## Possible states

- Choke function activated – The choke lever is pushed up all the way to the stop.
- Choke function deactivated – The choke lever is pushed down all the way to the stop.

### 6.11 Kick starter lever

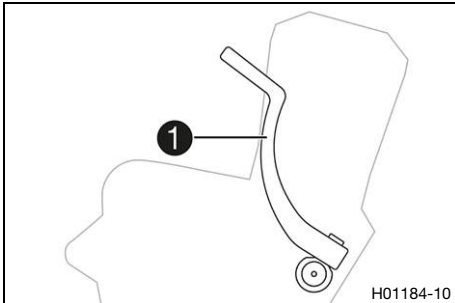

Kick starter lever ❶ is fitted on the right side of the engine. The kick starter lever can be swiveled.

#### **i** Info

Before riding, swing the kick starter lever inwards towards the engine.

### 6.12 Foot brake lever

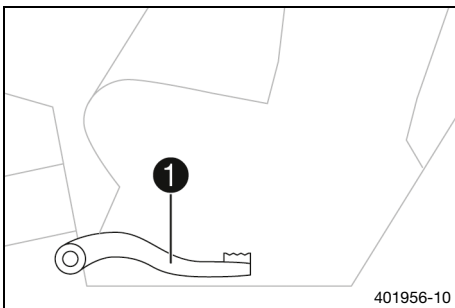

Foot brake lever ❶ is located in front of the right footrest. The rear brake is engaged with the foot brake lever.

### 6.13 Plug-in stand

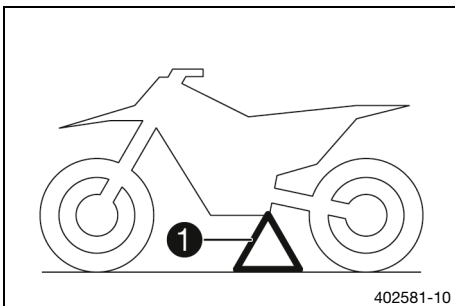

The fixture for plug-in stand ❶ is located on the frame on the left side of the vehicle. The plug-in stand is used to park the motorcycle.

#### **i** Info

Remove the plug-in stand before riding.

### 6.14 Service hour counter



Service hour counter ❶ is attached to the tail section under the left-hand side cover.

It shows the total number of service hours of the engine. The service hour counter begins counting when the engine is started and stops when the engine is switched off.

#### **i** Info

The value indicated by the service hour counter cannot be cleared or adjusted.

7.1 Advice on preparing for first use

 **Warning**  
**Danger of accidents** A lack of physical and mental readiness on the part of the child poses a major risk.  
 Children often underestimate or fail to recognize dangerous situations.

- Your child must already be able to ride a bicycle.
- Your child must be able to put the vehicle upright independently after a fall.
- Your child must understand that regulations and instructions from you or from other guardians must be followed.
- Make it clear to your child that he or she should not, under any circumstances, operate the vehicle without supervision.
- Make it clear to your child that he or she may only drive at speeds commensurate with the child's riding abilities and the road conditions.
- Do not ask too much of your child.

Do not consider participation in competitive activities until your child's stamina, riding techniques and motivation are at the necessary levels.

- Only let your child ride on the vehicle if he or she is physically and mentally ready.

 **Warning**  
**Risk of injury** Missing or poor protective clothing presents an increased safety risk.

- Ensure your child wears appropriate protective clothing such as helmet, boots, gloves as well as trousers and a jacket with protectors on all rides.
- Always use protective clothing for your child that is in good condition and meets the legal requirements.
- When you ride a motorcycle, set an example for your child and wear suitable protective clothing.

 **Warning**  
**Danger of crashing** Different tire tread patterns on the front and rear wheel impair the handling characteristic.  
 Different tire tread patterns can make the vehicle significantly more difficult to control.

- Make sure that only tires with a similar tire tread pattern are fitted to the front and rear wheel.

 **Warning**  
**Danger of accidents** An unadapted riding style constitutes a major risk.

- Ensure that your child adapts the riding speed to the road conditions and to his or her riding abilities.

 **Warning**  
**Danger of accidents** The vehicle is not designed to carry passengers.

- Make it clear to your child that he or she must not carry a passenger.

 **Warning**  
**Danger of accidents** The brake system fails in the event of overheating.  
 If the foot brake lever is not released, the brake linings drag continuously.

- Ensure that your child raises his or her foot from the foot brake lever if he or she does not want to brake.



## Warning

**Danger of accidents** The suspension components will become damaged or destroyed if overloaded.

- Do not exceed the maximum permissible weight of the rider.



## Warning

**Risk of misappropriation** People who act without authorization endanger themselves and others.

- Do not leave the vehicle unattended if the engine is running.
- Protect the vehicle against access by unauthorized persons.



## Info

When using the motorcycle, remember that others may be disturbed by excessive noise.

- Ensure that the pre-sale inspection work has been carried out by an authorized Husqvarna Motorcycles workshop.
- ✓ You will receive a delivery certificate when the vehicle is handed over.
- Read through the entire Owner's Manual together with your child before riding for the first time.



## Info

Pay special attention to the safety instructions and to the risk of injury.

Explain to your child the techniques of riding and falling, e.g., how shifting weight can influence handling characteristics.

- Familiarize your child with the controls.
- Adjust the basic position of the hand brake lever. (📖 p. 76)
- Adjust the basic position of the foot brake lever. 🦶 (📖 p. 85)
- Before using the vehicle for the first time, ensure that the basic settings of the chassis are suitable for the weight of your child.
- Allow your child to become accustomed to the handling of the motorcycle on suitable terrain, preferably on a large, open meadow.



## Info

To give your child a feeling for the brake system, you should push your child at first. Do not start the engine until your child is able to apply the necessary front brake pressure.

Initially, let your child ride to another person who can help your child stop and turn.

- Erect obstacles for your child to navigate around so that your child becomes accustomed to handling the vehicle.
- Your child should also try to ride as slowly as possible and in a standing position to get a better feeling for the motorcycle.
- Your child should not ride on terrain that exceeds your child's capabilities and experience.
- Your child should hold the handlebar firmly with both hands and keep his or her feet on the footrests when riding.
- Make sure the maximum permissible weight of the rider is not exceeded.

### Guideline

Maximum rider weight	45 kg (99 lb.)
Maximum rider size	< 130 cm (< 51.2 in)

- Check the spoke tension. (📖 p. 99)



## Info

The spoke tension must be checked after half an hour of operation.

- Run the engine in. (🗨️ p. 21)



## 7.2 Running in the engine

- During the running-in phase, do not exceed the specified engine performance.

Guideline

Maximum engine performance	
During the first 3 operating hours	< 70 %
During the first 5 operating hours	< 100 %

- Avoid fully opening the throttle!



## 8.1 Checks and maintenance measures when preparing for use

### **i** Info

Before every trip, check the condition of the vehicle and ensure that it is safe to operate. The vehicle must be in perfect technical condition when it is being operated.

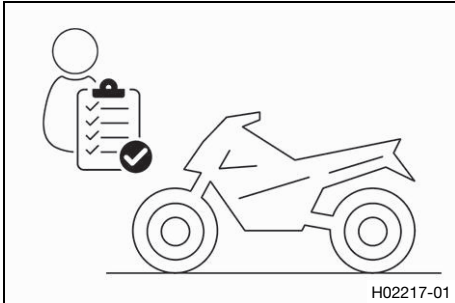

- Check the gear oil level. (📖 p. 113)
- Check the front brake fluid level. (📖 p. 78)
- Check the rear brake fluid level. (📖 p. 85)
- Check the front brake linings. (📖 p. 80)
- Check the brake linings of the rear brake. (📖 p. 87)
- Check that the brake system is functioning properly.
- Check the coolant level. (📖 p. 101)
- Check the chain for dirt. (📖 p. 66)
- Check the chain, rear sprocket, engine sprocket, and chain guide. (📖 p. 69)
- Check the chain tension. (📖 p. 67)
- Check the tire condition. (📖 p. 97)
- Check tire pressure. (📖 p. 98)
- Check the spoke tension. (📖 p. 99)

### **i** Info

The spoke tension must be checked regularly as incorrect spoke tension will strongly impair riding safety.

- Clean the dust boots of the fork legs. (📖 p. 42)
- Bleed the fork legs. (📖 p. 41)
- Check the air filter.
- Check the settings of all controls and ensure that they can be operated smoothly.
- Check all screws, nuts, and hose clips regularly for tightness.
- Check the fuel level.

## 8.2 Starting the vehicle



### **Danger**

**Danger of poisoning** Exhaust gases are toxic and inhaling them may result in unconsciousness and death.

- Always make sure there is sufficient ventilation when running the engine.
- Use effective exhaust extraction when starting or running the engine in an enclosed space.

### **Note**

**Engine failure** High rpm with a cold engine negatively impacts the lifespan of the engine.

- Ensure that the engine is always warmed up at low engine speeds.





### Info

If the motorcycle is unwilling to start, the cause can be old fuel in the float chamber. The flammable elements of the fuel evaporate after a long time of standing.  
If the float chamber is filled with fresh fuel, the engine starts immediately.

### Preliminary work

- Raise the motorcycle with a lift stand. (📖 p. 41)

### The motorcycle has been out of use for more than 1 week

- Empty the carburetor float chamber. 🗑️
- Turn the knurled screw on the fuel tap all the way counterclockwise.
  - ✓ Fuel can flow from the fuel tank to the carburetor.

### The engine is cold

#### (TC 50)

- Pull the choke knob up all the way to the stop and turn it by a max. ¼ turn.

#### (TC 50 MINI)

- Push the choke lever up all the way to the stop.
- Forcefully step on the kick starter lever, pushing it all the way forward.



### Info

Do not open the throttle.

### Final steps

- Remove the motorcycle from the lift stand. (📖 p. 41)



## 8.3 Starting off



### Info

The plug-in stand must be removed before riding.

- Open the throttle carefully.



## 8.4 Riding



### Info

If unusual noises occur while riding, stop immediately, switch off the engine, and contact an authorized Husqvarna Motorcycles workshop.

- If the choke function has been activated, deactivate it after the engine has warmed up.
- After reaching maximum speed by fully opening the throttle grip, turn the throttle back so it is ¾ open. This will barely reduce the speed, but fuel consumption will be considerably lower.
- Your child should always open the throttle only as much as the engine can handle – abruptly opening the throttle increases fuel consumption.
- Your child should switch off the engine if prolonged operation at idle speed or while stationary is imminent.

#### Guideline

≥ 2 min



## 8.5 Applying the brakes



### Warning

**Danger of accidents** Excessively forceful application of the brakes blocks the wheels.

- Explain to your child that he or she must adapt the braking to the traffic situation and the road conditions.



### Warning

**Danger of accidents** A spongy pressure point on the front or rear brake reduces braking efficiency.

- Check the brake system and do not allow your child to continue riding until the problem is eliminated. (Your authorized Husqvarna Motorcycles workshop will be glad to help.)



### Warning

**Danger of accidents** Moisture and dirt impair the brake system.

- Explain to your child that he or she must brake carefully several times to dry out and remove dirt from the brake linings and the brake discs.

- On sandy, wet, or slippery surfaces, use the rear brake.
- Always finish braking before you go into a bend.

## 8.6 Stopping, parking



### Warning

**Risk of misappropriation** People who act without authorization endanger themselves and others.

- Do not leave the vehicle unattended if the engine is running.
- Protect the vehicle against access by unauthorized persons.



### Warning

**Danger of burns** Some vehicle components become very hot when the vehicle is operated.

- Do not touch any parts such as the exhaust system, radiator, engine, shock absorber, or brake system before the vehicle parts have cooled down.
- Let the vehicle parts cool down before you perform any work on the vehicle.

### Note

**Material damage** The vehicle may be damaged by incorrect procedure when parking.

Significant damage may be caused if the vehicle rolls away or falls over.

The components for parking the vehicle are designed only for the weight of the vehicle.

- Park the vehicle on a firm and level surface.
- Ensure that nobody sits on the vehicle when the vehicle is parked on a stand.

### Note

**Fire hazard** Hot vehicle components pose a fire hazard and explosion risk.

- Do not park the vehicle near to materials which are highly flammable or explosive.
- Allow the vehicle to cool down before covering it.

- Apply the brakes on the motorcycle.
- Press and hold the switch-off button  while the engine is idling until the engine stops.
- Turn the knurled screw on the fuel tap all the way clockwise.
- Park the motorcycle on firm ground.

## 8.7 Transporting

### Note

**Danger of damage** The parked vehicle can roll away or fall over.

- Park the vehicle on a firm and level surface.

### Note

**Fire hazard** Hot vehicle components pose a fire hazard and explosion risk.

- Do not park the vehicle near to materials which are highly flammable or explosive.
- Allow the vehicle to cool down before covering it.

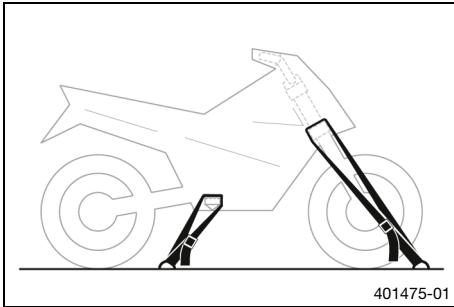

- Switch off the engine.
- Use tension belts or other suitable devices to secure the motorcycle against falling over or rolling away.

## 8.8 Refueling



### Danger

**Fire hazard** Fuel is highly flammable.

The fuel in the fuel tank expands when warm and can escape if overfilled.

- Do not fuel the vehicle in the vicinity of open flames or lit cigarettes.
- Switch off the engine for refueling.
- Make sure that no fuel is spilled; particularly not on hot parts of the vehicle.
- If any fuel is spilled, wipe it off immediately.
- Observe the specifications for refueling.



### Warning

**Danger of poisoning** Fuel is poisonous and a health hazard.

- Avoid skin, eye and clothing contact with fuel.
- Immediately consult a doctor if you swallow fuel.
- Do not inhale fuel vapors.
- In case of skin contact, rinse the affected area with plenty of water.
- Rinse the eyes thoroughly with water, and consult a doctor in case of fuel contact with the eyes.
- Change your clothing in case of fuel spills on them.



### Note

**Environmental hazard** Improper handling of fuel is a danger to the environment.

- Do not allow fuel to enter the groundwater, the soil, or the sewage system.

- Switch off the engine.
- Open the fuel tank filler cap. (📖 p. 15)

# 8 RIDING INSTRUCTIONS

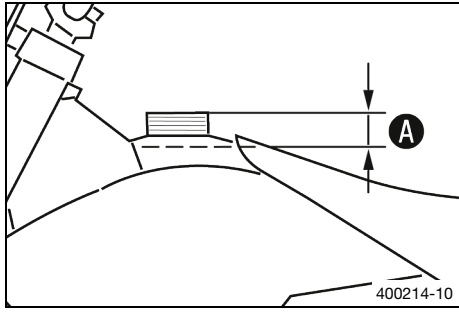

- Fill the fuel tank with fuel up to level **A**.

Guideline

Level <b>A</b>	35 mm (1.38 in)	
Fuel tank capacity, approx. (TC 50 MINI)	2.1 l (2.2 qt.)	Super unleaded (ROZ 95/RON 95/PON 91) (📖 p. 138)
Fuel tank capacity, approx. (TC 50)	2.3 l (2.4 qt.)	Super unleaded (95 octane) mixed with 2-stroke engine oil (1:60) (📖 p. 138)

- Close the fuel tank filler cap. (📖 p. 16)

## 8.9 Filling up with oil (TC 50 MINI)



### Warning

**Engine damage** The engine will not be lubricated unless there is 2-stroke oil in the oil tank.

- For a full fuel tank, fill the oil tank at least up to the **MIN**mark.

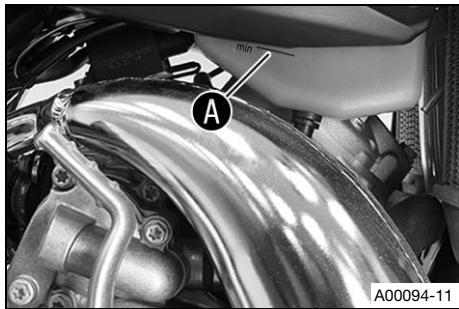

- Switch off the engine.
- Open the oil tank cap. (📖 p. 16)
- Fill the oil tank at least up to the **MIN**mark **A**.

Guideline

<b>MIN</b> mark	Sufficient for a single tank filling	
Oil tank contents ca.	0.2 l (0.2 qt.)	Engine oil, 2-stroke (📖 p. 137)

- Close the oil tank cap. (📖 p. 17)

## 9.1 Additional information

Any further work that results from the compulsory work or from the recommended work must be ordered separately and invoiced separately.

Different service intervals may apply in your country, depending on the local operating conditions.

Individual service intervals and scopes may change in the course of technical developments. The most up-to-date service schedule can always be found on Husqvarna Motorcycles Dealer.net. Your authorized Husqvarna Motorcycles dealer will be glad to advise you.

## 9.2 Required work

	Every 80 operating hours			
	Every 40 operating hours			
	Every 20 operating hours			
	After 10 operating hours			
Check the front brake linings. (📖 p. 80)	○	●	●	●
Check the brake linings of the rear brake. (📖 p. 87)	○	●	●	●
Check the brake discs. (📖 p. 77)	○	●	●	●
Check the brake lines for damage and leakage.	○	●	●	●
Change the foot brake cylinder sealing cup. 🛠️		●	●	●
Check the rear brake fluid level. (📖 p. 85)	○	●	●	●
Check the free travel of the foot brake lever. (📖 p. 84)	○	●	●	●
Check the frame. 🛠️ (📖 p. 73)		●	●	●
Check the link fork. 🛠️ (📖 p. 73)		●	●	●
Checking the fork bearing for play. 🛠️		●	●	●
Checking the shock absorber heim joint for play. 🛠️		●	●	●
Check the tire condition. (📖 p. 97)	○	●	●	●
Check tire pressure. (📖 p. 98)	○	●	●	●
Check the wheel bearing for play. 🛠️		●	●	●
Check the wheel hubs. 🛠️		●	●	●
Check the rim run-out. 🛠️	○	●	●	●
Check the spoke tension. (📖 p. 99)	○	●	●	●
Check the chain, rear sprocket, engine sprocket, and chain guide. (📖 p. 69)	○	●	●	●
Check the chain tension. (📖 p. 67)	○	●	●	●
Grease all moving parts (e.g., hand lever, chain, ...) and check for smooth operation. 🛠️	○	●	●	●
Check the front brake fluid level. (📖 p. 78)	○	●	●	●
Check the play of the handbrake lever. (📖 p. 76)	○	●	●	●
Check the steering head bearing play. (📖 p. 50)	○	●	●	●
Change the spark plug and spark plug connector. 🛠️		●	●	●
Change the gear oil. 🛠️ (📖 p. 114)	○		●	●
Check the gear oil level. (📖 p. 113)		●		
Check all hoses (e.g. fuel, cooling, bleeder, drainage, etc.) and sleeves for cracking, leaks, and incorrect routing. 🛠️	○	●	●	●
Check the antifreeze and coolant level. (📖 p. 100)	○	●	●	●
Check the cables for damage and routing without sharp bends. 🛠️	○	●	●	●
Check that the throttle cables are undamaged, routed without sharp bends, and set correctly.	○	●	●	●
Clean the air filter and air filter box. 🛠️ (📖 p. 63)	○	●	●	●

# 9 SERVICE SCHEDULE

	Every 80 operating hours	Every 40 operating hours	Every 20 operating hours	After 10 operating hours
Change the glass fiber yarn filling of the main silencer. 🛠️ (📖 p. 64)	•	•	•	
Service the fork. 🛠️			•	•
Perform the shock absorber service. 🛠️				•
Check the tightness of the easily accessible, safety-relevant screws and nuts. 🛠️	○	•	•	•
Check the idle speed. 🛠️	○	•	•	•
Check the clutch setting. 🛠️ (📖 p. 109)		•	•	•
Final check: Check the vehicle for safe operation and take a test ride. 🛠️	○	•	•	•
Make a service entry in <b>Husqvarna Motorcycles Dealer.net</b> . 🛠️	○	•	•	•

- One-time interval
- Periodic interval

## 9.3 Recommended work

	Every 80 operating hours	After 20 operating hours / Every 20 operating hours	After 10 operating hours	every 48 months	every 12 months
Change the front brake fluid. 🛠️	•	•			
Change the rear brake fluid. 🛠️	•	•			
Change the rear brake fluid. 🛠️	•	•			
Service the fork. 🛠️			○		
Perform the shock absorber service. 🛠️				○	
Lubricate the steering head bearing. 🛠️ (📖 p. 51)	•	•			
Check/adjust the carburetor components. 🛠️	•	•			
Change the coolant. 🛠️ (📖 p. 103)		•			
Perform minor engine service. Check the cylinder and piston. Check the inlet membrane.) 🛠️					•
Perform major engine service including removing and installing engine. (Check the clutch. Change the piston. Change the connecting rod, conrod bearing, and crank pin. Check the transmission. Change the crankshaft bearing. Change all engine bearings.) 🛠️					•

- One-time interval
- Periodic interval

## 10.1 Checking the basic chassis setting with rider's weight

### **i** Info

When adjusting the basic chassis setting, first adjust the shock absorber and then the fork.

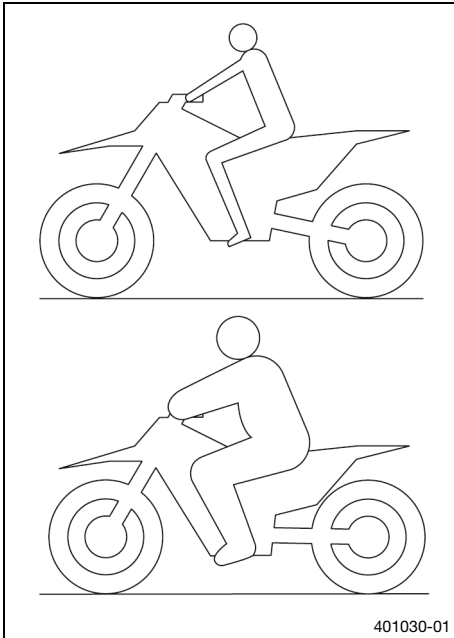

- For optimal motorcycle riding characteristics and to avoid damage to forks, shock absorbers, link fork and frame, the basic settings of the suspension components must match the rider's weight.
- This vehicle is delivered pre-set for a standard rider's weight (with full protective clothing).

#### Guideline

Standard rider weight	25 ... 35 kg (55 ... 77 lb.)
-----------------------	------------------------------

- If the rider's weight is above or below this range, the basic setting of the suspension components must be adjusted accordingly.
- Small weight differences can be compensated by adjusting the spring preload, but in the case of large weight differences, the springs must be replaced.



## 10.2 Air suspension XACT 5235 (TC 50)

Air suspension **WP XACT 5235** is used in the fork.

In this system, suspension is located in the left fork leg and damping in the right fork leg.

As fork springs are no longer required, a significant weight advantage is achieved when compared to conventional forks. The response on slightly uneven surfaces is significantly improved.

In normal driving mode, suspension is provided exclusively by an air cushion. A steel spring is located in the left fork leg as an end stop.

### **i** Info

If the fork is frequently overloaded, then the air pressure in the fork must be increased to avoid damage to the fork and frame.

The air pressure in the fork can be quickly adjusted to the rider's weight, surface conditions and the rider's preference using a fork airpump. The fork does not have to be dismantled. The time consuming mounting of harder or softer fork springs is not required.

If the air chamber loses air due to a damaged seal, the fork will still not sag. In this case the air is retained in the fork. The suspension travel is maintained as far as possible. The damping becomes harder and the riding comfort reduces.

The rebound damping can be adjusted.

The rebound adjustment is located at the upper end of the right fork leg.

## 10.3 Compression damping of the shock absorber (TC 50)

The compression damping of the shock absorber is divided into two ranges: high-speed and low-speed. High-speed and low-speed refer to the compression speed of the rear wheel suspension and not to the vehicle speed.

The high-speed compression adjuster has an effect, for example, when landing after a jump: the rear wheel suspension compresses quickly.

The low-speed compression adjuster has an effect, for example, when riding over long ground swells: the rear wheel suspension compresses slowly.

These two ranges can be adjusted separately, although the transition between high-speed and low-speed is gradual. Thus, modifications in the high-speed range affect the compression damping in the low-speed range and vice versa.

## 10.4 Adjusting the low-speed compression damping of the shock absorber (TC 50)



### Caution

**Risk of injury** Parts of the shock absorber will move around if the shock absorber is detached incorrectly.

The shock absorber is filled with highly compressed nitrogen.

- Please follow the description provided. (Your authorized Husqvarna Motorcycles workshop will be glad to help.)



### Info

The effect of the low-speed compression adjuster can be seen in slow to normal compression of the shock absorber.

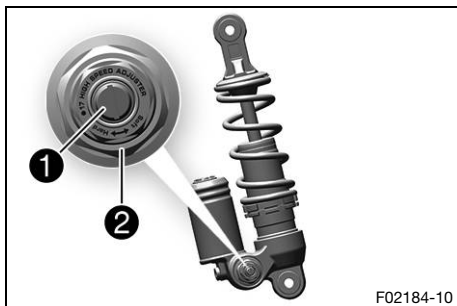

- Turn adjusting screw **1** clockwise with a screwdriver as far as the last perceptible click.



### Info

Do not loosen fitting **2**!

- Turn counterclockwise by the number of clicks corresponding to the shock absorber type.

### Guideline

Low-speed compression damping	
Comfort	18 clicks
Standard	15 clicks
Sport	12 clicks



### Info

Turn clockwise to increase damping; turn counterclockwise to reduce damping.



## 10.5 Adjusting the high-speed compression damping of the shock absorber (TC 50)



### Caution

**Risk of injury** Parts of the shock absorber will move around if the shock absorber is detached incorrectly.

The shock absorber is filled with highly compressed nitrogen.

- Please follow the description provided. (Your authorized Husqvarna Motorcycles workshop will be glad to help.)



### Info

The effect of the high-speed compression adjuster can be seen in fast compression of the shock absorber.

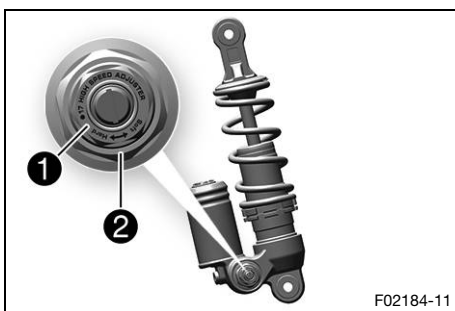

- Push the splash protector to the side.
- Using an open end wrench, turn adjusting screw ① clockwise all the way.



### Info

Do not loosen fitting ②!

- Turn counterclockwise by the number of turns corresponding to the shock absorber type.

Guideline

High-speed compression damping	
Comfort	2.5 turns
Standard	2 turns
Sport	1.5 turns



### Info

Turn clockwise to increase damping; turn counterclockwise to reduce damping.

- Position the splash protector.



## 10.6 Adjusting the rebound damping of the shock absorber



### Caution

**Risk of injury** Parts of the shock absorber will move around if the shock absorber is detached incorrectly.

The shock absorber is filled with highly compressed nitrogen.

- Please follow the description provided. (Your authorized Husqvarna Motorcycles workshop will be glad to help.)

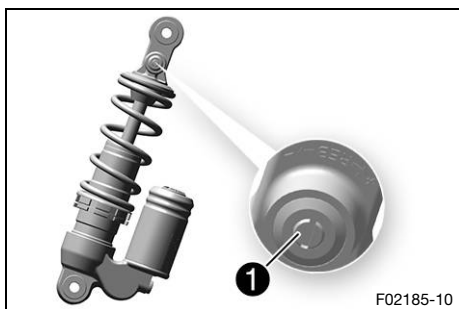

### (TC 50)

- Turn adjusting screw **1** clockwise up to the last perceptible click.
- Turn counterclockwise by the number of clicks corresponding to the shock absorber type.

#### Guideline

Rebound damping	
Comfort	17 clicks
Standard	15 clicks
Sport	13 clicks



#### Info

Turn clockwise to increase the damping; turn counterclockwise to reduce damping when the shock absorber rebounds.

### (TC 50 MINI)

- Raise the motorcycle with a lift stand. (📖 p. 41)
- Remove nut **1**.

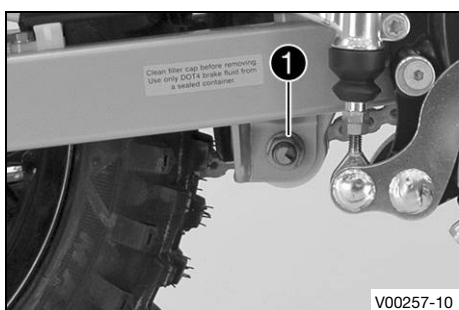

- Remove screw **2**.
- Pull the shock absorber out of the support and push the rear wheel upwards.

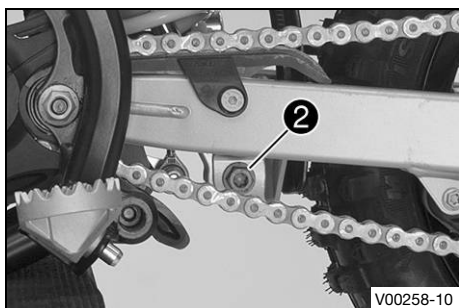

- Turn adjusting screw **3** clockwise up to the last perceptible click.
- Turn counterclockwise by the number of clicks corresponding to the shock absorber type.

#### Guideline

Rebound damping	
Standard	12 clicks



#### Info

Turn clockwise to increase the damping; turn counterclockwise to reduce damping when the shock absorber rebounds.

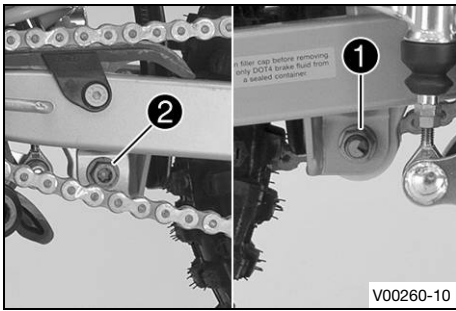

- Position the shock absorber and rear wheel.
- Mount and tighten screw ② and nut ①.

**Guideline**

Screw, bottom shock absorber	M10	45 Nm (33.2 lbf ft) <b>Loctite®243™</b>
------------------------------	-----	--

- Remove the motorcycle from the lift stand. (📖 p. 41)

## 10.7 Measuring the rear wheel dimension unloaded

**Preparatory work**

- Raise the motorcycle with a lift stand. (📖 p. 41)

**Main work**

- Measure the vertical distance between the rear axle and a fixed point such as a marking on the side cover.
- Note the value as dimension ①.

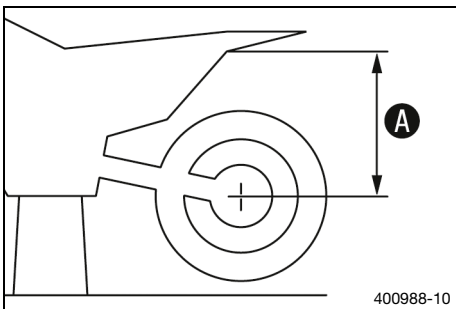

**Finishing work**

- Remove the motorcycle from the lift stand. (📖 p. 41)

## 10.8 Checking the static sag of the shock absorber

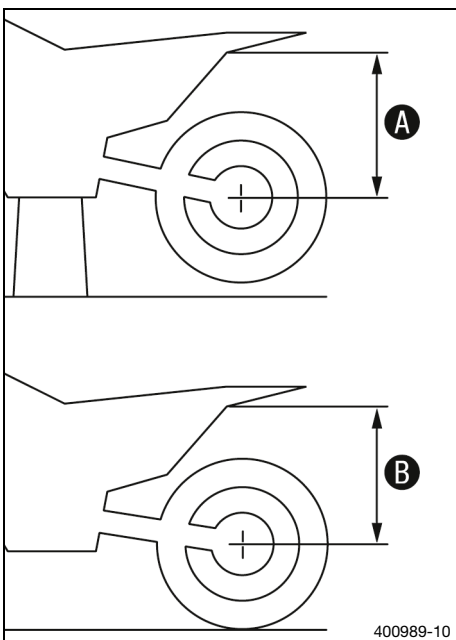

- Measure dimension ① of rear wheel unloaded. (📖 p. 33)
- Hold the motorcycle upright with aid of an assistant.
- Measure the distance between rear axle and fixed point again.
- Note the value as dimension ②.

**i Info**  
The static sag is the difference between measurements ① and ②.

- Check the static sag.

Static sag (TC 50)	12 mm (0.47 in)
--------------------	-----------------

Static sag (TC 50 MINI)	10 mm (0.39 in)
-------------------------	-----------------

- » If the static sag is less or more than the specified value:
  - Adjust the spring preload of the shock absorber. (📖 p. 34)

## 10.9 Checking the riding sag of the shock absorber

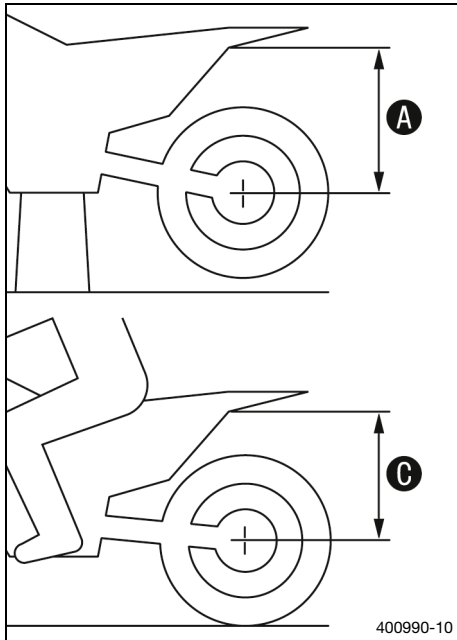

- Measure dimension **A** of rear wheel unloaded. (📖 p. 33)
- With another person holding the motorcycle, the rider, wearing full protective clothing, sits on the seat in a normal sitting position (feet on footrests) and bounces up and down a few times.
  - ✓ The rear wheel suspension levels out.
- Another person now measures the distance between the rear axle and the fixed point.
- Note the value as dimension **C**.



### Info

The riding sag is the difference between measurements **A** and **C**.

- Check riding sag.

Riding sag (TC 50)	80 mm (3.15 in)
--------------------	-----------------

Riding sag (TC 50 MINI)	65 mm (2.56 in)
-------------------------	-----------------

- » If the riding sag differs from the specified measurement:
  - Adjust the riding sag. (🔧📖 p. 36)

## 10.10 Adjusting the spring preload of the shock absorber 🔧



### Caution

**Risk of injury** Parts of the shock absorber will move around if the shock absorber is detached incorrectly.

The shock absorber is filled with highly compressed nitrogen.

- Please follow the description provided. (Your authorized Husqvarna Motorcycles workshop will be glad to help.)

### Preparatory work

#### (TC 50)

- Raise the motorcycle with a lift stand. (📖 p. 41)

#### (TC 50 MINI)

- Raise the motorcycle with a lift stand. (📖 p. 41)
- Remove the rear wheel. (🔧📖 p. 94)
- Remove the shock absorber. (🔧📖 p. 59)
- After removing the shock absorber, clean it thoroughly.

### Main work

#### (TC 50)

- Measure the full spring length while it is under tension and note down the value.
- Loosen retaining ring **1**.
- Turn adjusting ring **2** until the spring is no longer under tension.

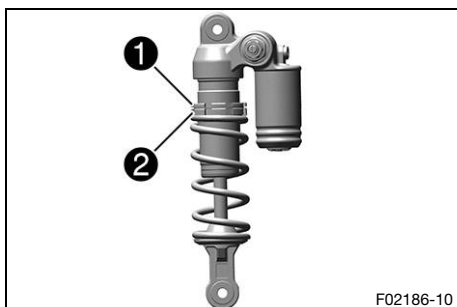

Hook wrench (T304)
--------------------

Hook wrench (T1533)
---------------------

- Measure the total spring length while the spring is not under tension.
- Tighten the spring to the specified measurement by turning adjusting ring ②.

Guideline

Spring preload	3 mm (0.12 in)
----------------	----------------

**i Info**

The spring preload is the difference between the relaxed spring length and the tensioned spring length. Depending on the static sag and/or the riding sag, it may be necessary to increase or decrease the spring preload.

- Tighten retaining ring ①.

**(TC 50 MINI)**

- Measure the full spring length while it is under tension and note down the value.
- Loosen retaining ring ①.
- Turn adjusting ring ② until the spring is no longer under tension.

Hook wrench (T304)
Hook wrench (T1533)

- Measure the total spring length while the spring is not under tension.
- Tighten the spring to the specified measurement by turning adjusting ring ②.

Guideline

Spring preload	
Standard	5 mm (0.2 in)

**i Info**

The spring preload is the difference between the relaxed spring length and the tensioned spring length. Depending on the static sag and/or the riding sag, it may be necessary to increase or decrease the spring preload.

- Tighten retaining ring ①.

**Finishing work**

- Install the shock absorber. 🛠️ (p. 60)
- Remove the motorcycle from the lift stand. 📖 (p. 41)

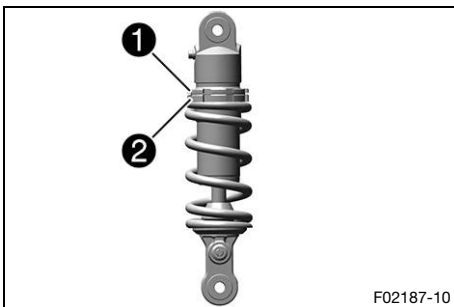

## 10.11 Adjusting the riding sag 🛠️

### Preparatory work

#### (TC 50)

- Raise the motorcycle with a lift stand. (📖 p. 41)

#### (TC 50 MINI)

- Raise the motorcycle with a lift stand. (📖 p. 41)
- Remove the rear wheel. 🛠️ (📖 p. 94)
- Remove the shock absorber. 🛠️ (📖 p. 59)
- After removing the shock absorber, clean it thoroughly.

### Main work

- Choose and mount a suitable spring.

#### Guideline

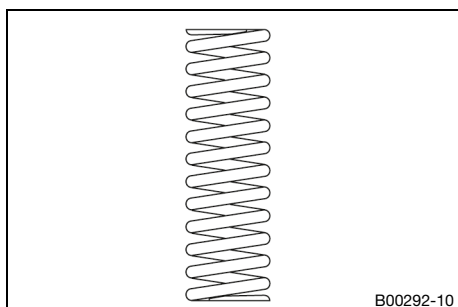

Spring rate (TC 50)	
Weight of rider: 15 ... 25 kg (33 ... 55 lb.)	25 N/mm (143 lb/in)
Weight of rider (stan- dard): 25 ... 35 kg (55 ... 77 lb.)	30 N/mm (171 lb/in)
Weight of rider: 35 ... 45 kg (77 ... 99 lb.)	35 N/mm (200 lb/in)
Spring rate (TC 50 MINI)	
Weight of rider: 15 ... 25 kg (33 ... 55 lb.)	65 N/mm (371 lb/in)
Weight of rider (stan- dard): 25 ... 35 kg (55 ... 77 lb.)	75 N/mm (428 lb/in)
Weight of rider: 35 ... 45 kg (77 ... 99 lb.)	85 N/mm (485 lb/in)

### **i** Info

The spring rate is shown on the outside of the spring. Smaller weight differences can be compensated by changing the spring preload.

### Finishing work

- Install the shock absorber. 🛠️ (📖 p. 60)
- Remove the motorcycle from the lift stand. (📖 p. 41)
- Check the static sag of the shock absorber. (📖 p. 33)
- Check the riding sag of the shock absorber. (📖 p. 34)
- Adjust the rebound damping of the shock absorber. (📖 p. 31)

## 10.12 Checking the basic setting of the fork

### **i** Info

For various reasons, no exact riding sag can be determined for the fork.

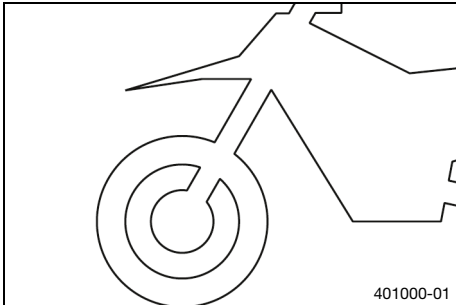

### (TC 50)

- Smaller differences in the rider's weight can be compensated for by the fork air pressure.
- However, if the fork frequently bottoms out (hard end stop on compression), the fork air pressure must be increased, within the specified values, to avoid damage to the fork and frame.

### (TC 50 MINI)

- As with the shock absorber, smaller differences in the rider's weight can be compensated by the spring preload.
- However, if the fork frequently bottoms out (hard end stop on compression), harder springs must be fitted to avoid damage to the fork and frame.



## 10.13 Adjusting the fork air pressure (TC 50)



### Warning

**Danger of accidents** Modifications to the suspension setting may seriously alter the handling characteristic.

Extreme modifications to the suspension setting may cause a serious deterioration in the handling characteristic and overload components.

- Only make adjustments within the recommended range.
- Make sure your child rides slowly to start with after making adjustments in order that he or she can assess the new handling characteristic.

### **i** Info

Check or adjust the air pressure under the same conditions at the earliest 5 minutes after switching off the engine.

The air suspension is located in the left fork leg. The rebound damping is located in the right fork leg.

### Preparatory work

- Raise the motorcycle with a lift stand. (📖 p. 41)

### Main work

- Remove protection cap ①.
- Push together fork airpump ② fully.

Fork airpump (79412966100)
----------------------------

### **i** Info

The fork airpump is included as part of the motorcycle's accessory pack.

- Connect the fork airpump to the left fork leg.
  - ✓ The fork airpump indicator switches on automatically.
  - ✓ A little air escapes from the fork leg when connecting.

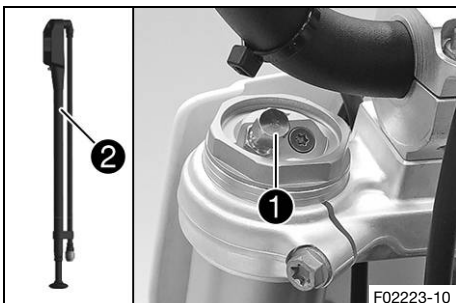

**i Info**

This is due to the volume of the hose and not due to a defect in the fork airpump or the fork. Observe the accompanying instructions for Husqvarna Motorcycles accessories.

- Adjust the air pressure as specified.

Guideline

Air pressure	2 bar (29 psi)
Gradual changing of the air pressure in steps of	0.2 bar (3 psi)
Minimum air pressure	1.4 bar (20 psi)
Maximum air pressure	4 bar (58 psi)

**i Info**

Never adjust the air pressure to a value outside the stated range.

- Disconnect the fork airpump from the left fork leg.
  - ✓ When disconnecting, excess pressure will escape from the hose – the fork leg itself does not lose any air.
  - ✓ The fork airpump indicator switches off automatically after 80 seconds.
- Mount the protection cap.

**i Info**

Only mount the protection cap by hand.

**Finishing work**

- Remove the motorcycle from the lift stand. (📖 p. 41)

## 10.14 Adjusting the rebound damping of the fork (TC 50)

**i Info**

The hydraulic rebound damping determines the fork suspension behavior.

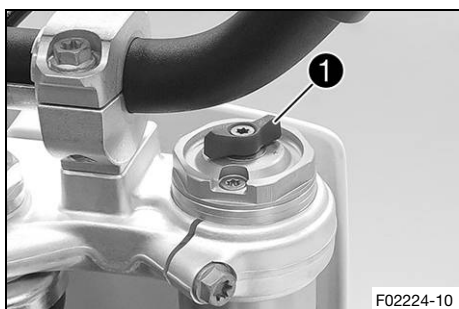

- Turn adjuster ① clockwise all the way.

**i Info**

Adjuster ① is located at the upper end of the right fork leg.

- Turn counterclockwise by the number of clicks corresponding to the fork type.

Guideline

Rebound damping	
Comfort	15 clicks
Standard	12 clicks
Sport	10 clicks





### Info

Turn clockwise to increase the damping; turn counterclockwise to reduce damping when the shock absorber rebounds.

## 10.15 Handlebar position

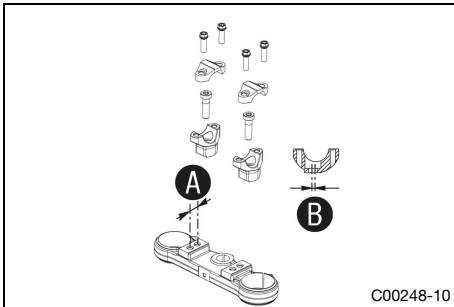

On the upper triple clamp, there are 2 holes at a distance of **A** to each other.

Hole distance <b>A</b>	15 mm (0.59 in)
------------------------	-----------------

The holes on the handlebar supports are placed at a distance of **B** from the center.

Hole distance <b>B</b>	3.5 mm (0.138 in)
------------------------	-------------------

The handlebar supports can be mounted in four different positions. This allows the handlebar to be mounted in the most comfortable position for the rider.

## 10.16 Adjusting the handlebar position



### Warning

**Danger of accidents** A repaired handlebar poses a safety risk.

If the handlebar is bent or straightened, the material becomes fatigued. The handlebar may break as a result.

- Change the handlebar if the handlebar is damaged or bent.

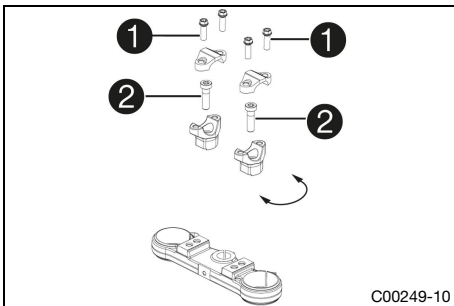

- Remove screws **1**. Take off the handlebar clamps. Remove the handlebar and lay it to one side.



### Info

Cover the components to protect them against damage. Do not kink the cables and lines.

- Remove screws **2**. Take off handlebar supports.
- Place handlebar supports in required position. Mount and tighten screws **2**.

#### Guideline

Screw, handlebar support	M10	40 Nm (29.5 lbf ft) <b>Loctite®243™</b>
--------------------------	-----	--

- Position the handlebar.



### Info

Make sure the cables and wiring are positioned correctly.

- Position the handlebar clamps. Mount screws **1** and tighten evenly.

## Guideline

Screw, handlebar clamp	M8	20 Nm (14.8 lbf ft)
------------------------	----	---------------------



### Info

Make sure the installed gaps are even.

## 10.17 Adjusting the seat height ↴



### Warning

**Danger of accidents** Modifications to the suspension setting may seriously alter the handling characteristic.

- Make sure your child rides slowly to start with after making adjustments in order that he or she can assess the new handling characteristic.

### Preparatory work

- Raise the motorcycle with a lift stand. (📖 p. 41)

### Main work

- Remove nut **1**.

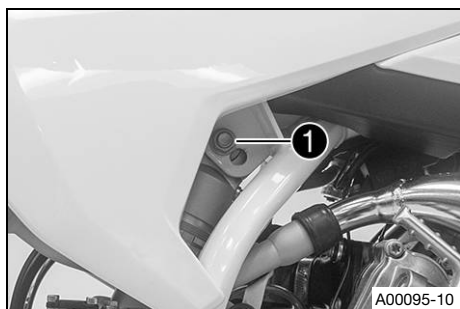

- Hold the rear wheel with the link fork and remove screw **2**.
- Position the shock absorber according to the required seat height.

### Guideline

Low seat position (standard)	<b>A</b>
High seat position	<b>B</b>

- Position screw **2**.

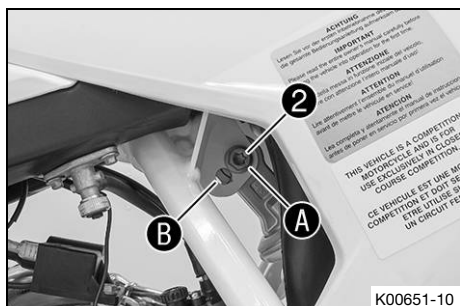

- Mount nut **1** and tighten the fitting.

### Guideline

Screw, top shock absorber	M10	45 Nm (33.2 lbf ft) <b>Loctite®243™</b>
---------------------------	-----	--

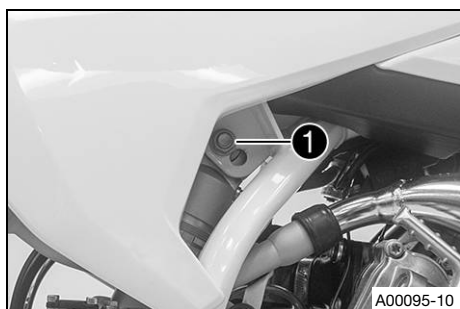

### Finishing work

- Remove the motorcycle from the lift stand. (📖 p. 41)

## 11.1 Raising the motorcycle with a lift stand

### Note

**Danger of damage** The parked vehicle can roll away or fall over.

- Park the vehicle on a firm and level surface.

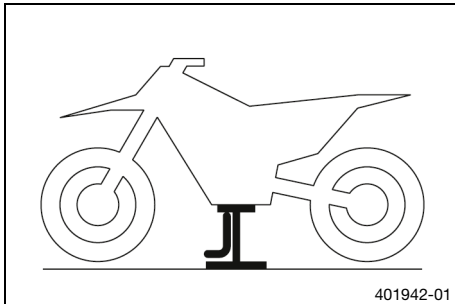

- Raise the motorcycle at the frame underneath the engine.

Lift stand (80329955100)

- ✓ Neither wheel is in contact with the ground.
- Secure the motorcycle against falling over.

## 11.2 Removing the motorcycle from the lift stand

### Note

**Danger of damage** The parked vehicle can roll away or fall over.

- Park the vehicle on a firm and level surface.

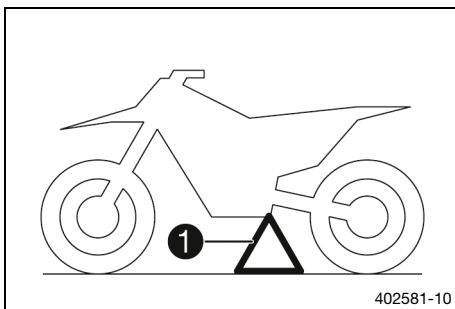

- Remove the motorcycle from the lift stand.
- Remove the lift stand.
- To park the motorcycle, insert plug-in stand ① into the plug-in stand bracket on the left side of the vehicle.



### Info

Remove the plug-in stand before riding.

## 11.3 Bleeding the fork legs

### Preparatory work

- Raise the motorcycle with a lift stand. (📖 p. 41)

### Main work (TC 50)

- Release bleeder screws ①.
- ✓ Any excess pressure escapes from the interior of the fork.
- Tighten the bleeder screws.

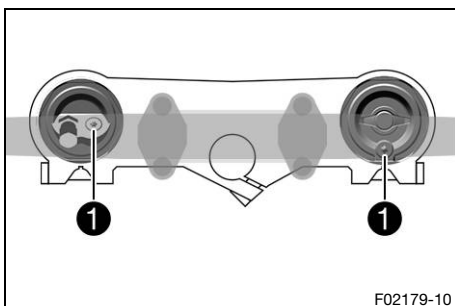

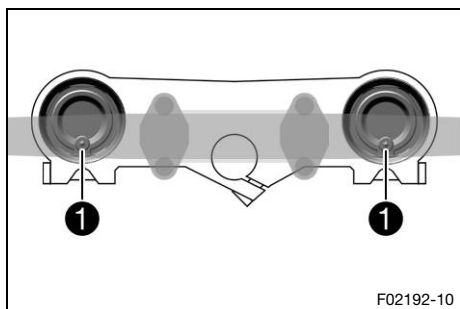

## (TC 50 MINI)

- Release bleeder screws ①.
- ✓ Any excess pressure escapes from the interior of the fork.
- Tighten the bleeder screws.

### Finishing work

- Remove the motorcycle from the lift stand. (📖 p. 41)

## 11.4 Cleaning the dust boots of the fork legs

### Preparatory work

- Raise the motorcycle with a lift stand. (📖 p. 41)
- Remove the fork protector. (📖 p. 43)

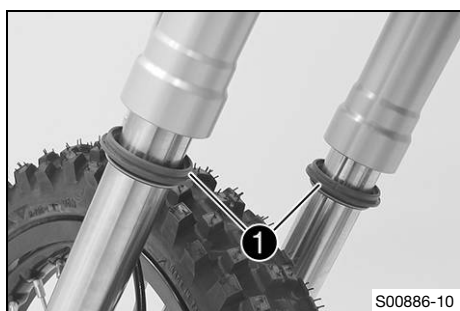

### Main work

- Push dust boots ① of both fork legs downward.

#### **i** Info

The dust boots remove dust and coarse dirt particles from the inside fork tubes. Over time, dirt can accumulate behind the dust boots. If this dirt is not removed, the seals rings behind can start to leak.



#### **Warning**

**Danger of accidents** Oil or grease on the brake discs reduces the braking effect.

- Always keep the brake discs free of oil and grease.
- Clean the brake discs with brake cleaner when necessary.

- Clean and oil the dust boots and inner fork tubes of both fork legs.

Universal oil spray (📖 p. 140)

- Press the dust boots back into the installation position.
- Remove the excess oil.

### Finishing work

- Install the fork protector. (📖 p. 43)
- Remove the motorcycle from the lift stand. (📖 p. 41)

## 11.5 Removing the fork protector

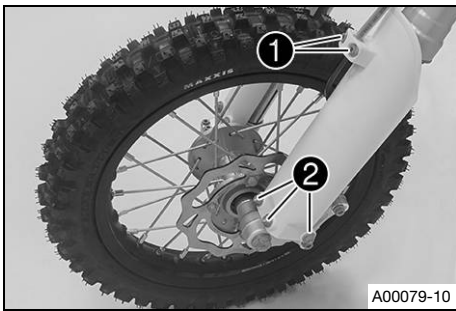

- Remove screws ① and take off the clamp.
- Remove screws ② on the left fork leg. Take off the fork protector.



- Remove screws ③ on the right fork leg. Take off the fork protector.

## 11.6 Installing the fork protector



- Position fork protector on the right fork leg. Mount and tighten screws ①.

Guideline

Remaining screws, chassis	M6	10 Nm (7.4 lbf ft)
---------------------------	----	--------------------

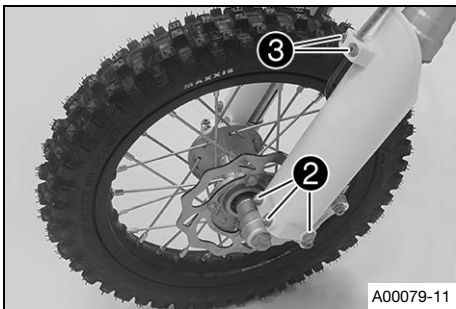

- Position fork protector on left fork leg. Mount and tighten screws ②.

Guideline

Remaining screws, chassis	M6	10 Nm (7.4 lbf ft)
---------------------------	----	--------------------

- Position the brake line and the clamp. Mount and tighten screws ③.

Guideline

Screw, brake line bracket	<b>EJOT</b>	1.7 Nm (1.25 lbf ft)
---------------------------	-------------	----------------------

## 11.7 Removing fork legs

### Preparatory work

- Raise the motorcycle with a lift stand. (📖 p. 41)
- Remove the front wheel. (🔧 p. 93)

### Main work

- Remove screws ❶ and take off the clamp.
- Remove screws ❷ and take off the brake caliper.
- Allow the brake caliper and brake line to hang loosely to the side.

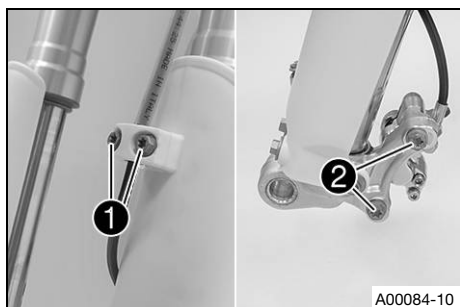

### Info

Do not kink the brake line.

### (TC 50)

- Loosen screws ❸. Remove the left fork leg.
- Loosen screws ❹. Remove the right fork leg.

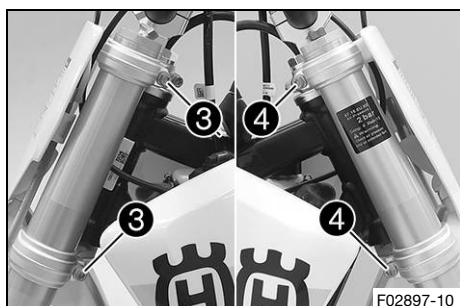

### (TC 50 MINI)

- Loosen screws ❸. Remove the left fork leg.
- Loosen screws ❹. Remove the right fork leg.

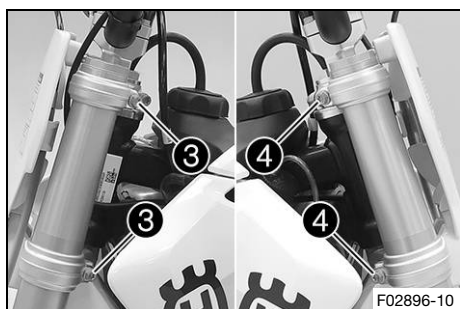

## 11.8 Installing the fork legs

### Main work

#### (TC 50)

- Position the fork legs.
- ✓ Bleeder screws ❶ are positioned toward the rear.

### Info

The second milled groove in the fork leg must be flush with the upper edge of the upper triple clamp.

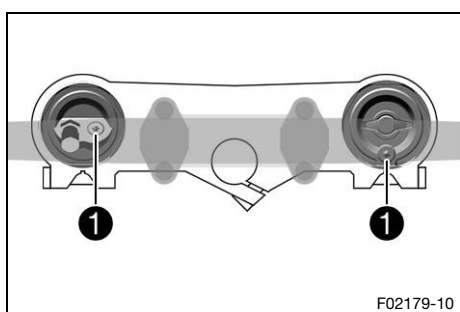

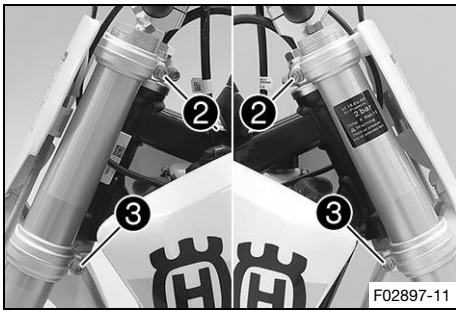

- Tighten screws ②.

Guideline

Screw, top triple clamp	M8	20 Nm (14.8 lbf ft)
-------------------------	----	---------------------

- Tighten screws ③.

Guideline

Screw, bottom triple clamp	M8	15 Nm (11.1 lbf ft)
----------------------------	----	---------------------

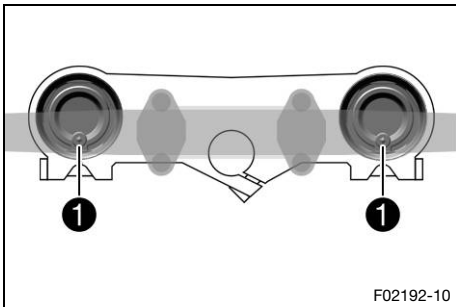

### (TC 50 MINI)

- Position the fork legs.
- ✓ Bleeder screws ① are positioned toward the rear.



#### Info

The second milled groove (from the top) must be flush with the upper edge of the upper triple clamp.

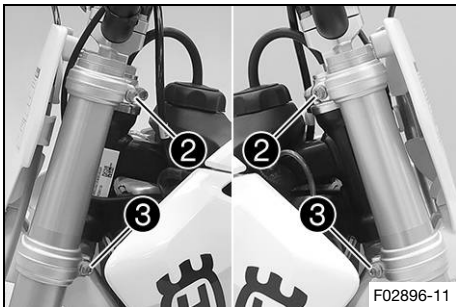

- Tighten screws ②.

Guideline

Screw, top triple clamp	M8	20 Nm (14.8 lbf ft)
-------------------------	----	---------------------

- Tighten screws ③.

Guideline

Screw, bottom triple clamp	M8	15 Nm (11.1 lbf ft)
----------------------------	----	---------------------

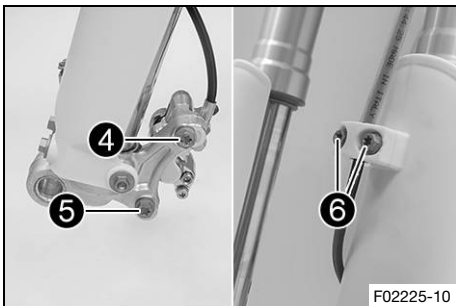

- Position the brake caliper, mount screw ④, and tighten.

Guideline

Screw, front brake caliper	M8x60	20 Nm (14.8 lbf ft) <b>Loctite®243™</b>
----------------------------	-------	--

- Mount and tighten screw ⑤.

Guideline

Screw, front brake caliper	M8x40	20 Nm (14.8 lbf ft) <b>Loctite®243™</b>
----------------------------	-------	--

- Position the brake line and the clamp. Mount and tighten screws ⑥.

Guideline

Screw, brake line bracket	<b>EJOT</b>	1.7 Nm (1.25 lbf ft)
---------------------------	-------------	----------------------

### Finishing work

- Install the front wheel. 🛠️ (p. 93)

## 11.9 Removing the lower triple clamp

### Preparatory work

- Raise the motorcycle with a lift stand. (p. 41)
- Remove the front wheel. (p. 93)
- Remove the fork legs. (p. 44)
- Remove the start number plate. (p. 54)
- Remove front fender. (p. 54)

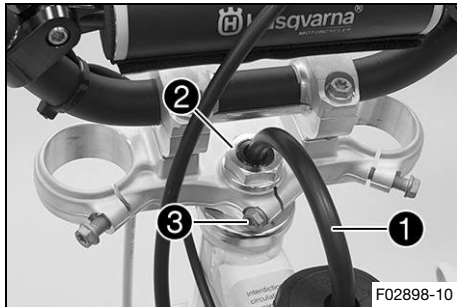

### Main work

- Pull fuel tank breather 1 out of the steering stem.
- Remove nut 2.
- Release screw 3, take off the upper triple clamp with the handlebar and set aside.



### Info

Cover the components to protect them against damage.  
Do not kink the cables and lines.

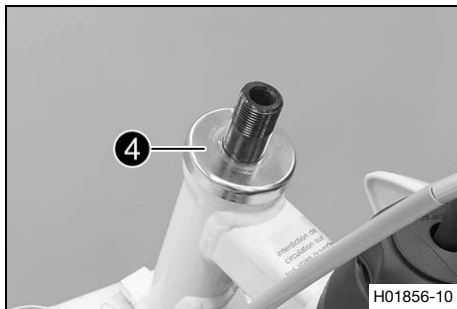

- Remove protective ring 4.
- Remove the lower triple clamp with the steering stem.
- Remove the upper steering head bearing.



## 11.10 Installing the lower triple clamp

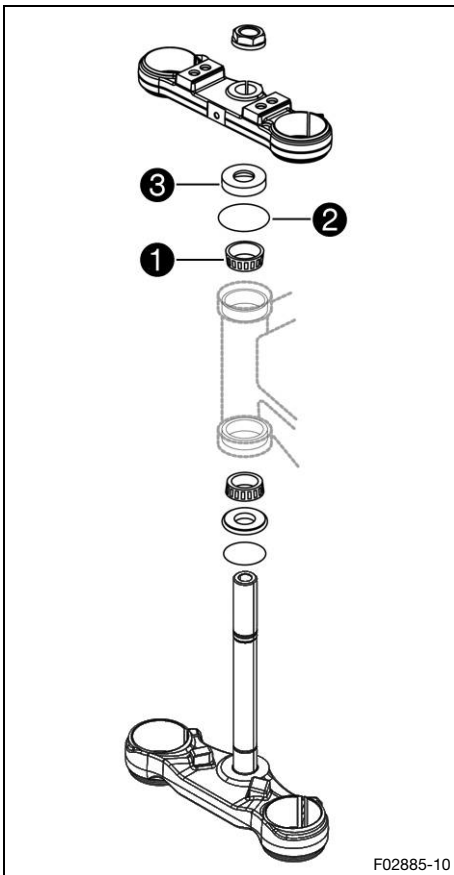

### Main work

- Clean the bearing and sealing elements, check for damage, and grease.

High viscosity grease (📖 p. 139)

- Insert the lower triple clamp with the steering stem. Mount upper steering head bearing ①.
- Check whether upper steering head seal ② is correctly positioned.
- Push on protective ring ③.

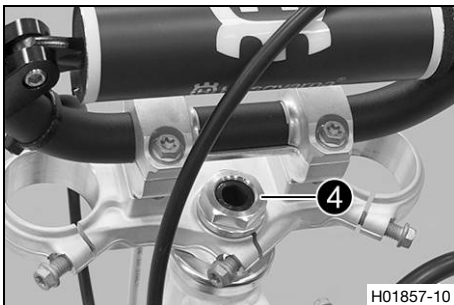

- Position the upper triple clamp with the handlebar.
- Mount nut ④, but do not tighten it yet.

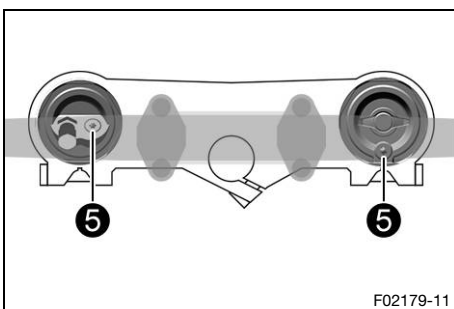

### (TC 50)

- Position the fork legs.
- ✓ Bleeder screws ⑤ are positioned toward the rear.



### Info

The second milled groove (from the top) must be flush with the upper edge of the upper triple clamp.

# 11 SERVICE WORK ON THE CHASSIS

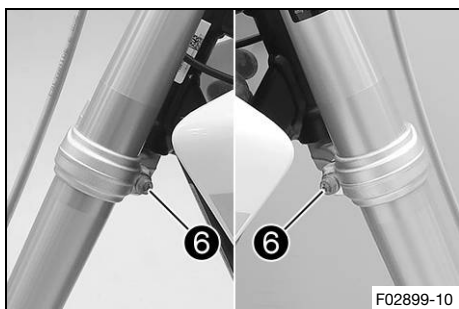

- Tighten screws ⑥.

Guideline

Screw, bottom triple clamp	M8	15 Nm (11.1 lbf ft)
----------------------------	----	---------------------



- Tighten nut ④.

Guideline

Nut, steering head	M20x1.5	10 Nm (7.4 lbf ft)
--------------------	---------	--------------------

- Position the fuel tank breather ⑦ in the steering stem.



- Tighten screw ⑧.

Guideline

Screw, top triple clamp	M8	20 Nm (14.8 lbf ft)
-------------------------	----	---------------------

- Using a plastic hammer, tap lightly on the upper triple clamp to avoid stresses.

- Tighten screws ⑨.

Guideline

Screw, top triple clamp	M8	20 Nm (14.8 lbf ft)
-------------------------	----	---------------------

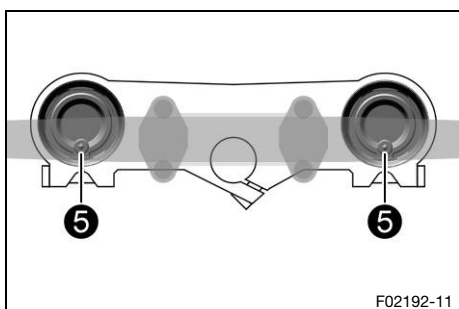

## (TC 50 MINI)

- Position the fork legs.

- ✓ Bleeder screws ⑤ are positioned toward the rear.



### Info

The second milled groove (from the top) must be flush with the upper edge of the upper triple clamp.

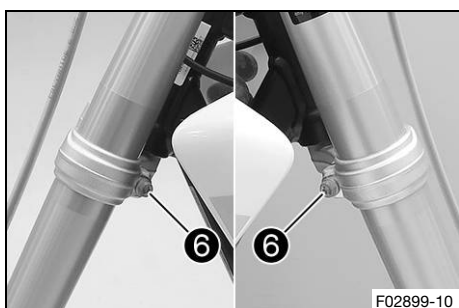

- Tighten screws ⑥.

Guideline

Screw, bottom triple clamp	M8	15 Nm (11.1 lbf ft)
----------------------------	----	---------------------

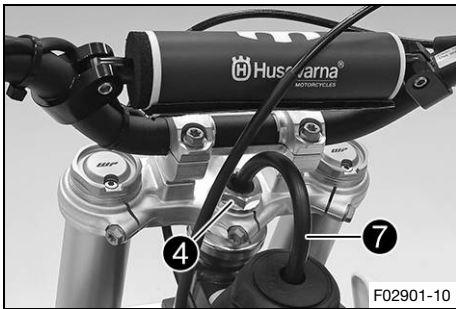

- Tighten nut **4**.

Guideline

Nut, steering head	M20x1.5	10 Nm (7.4 lbf ft)
--------------------	---------	--------------------

- Position the fuel tank breather **7** in the steering stem.

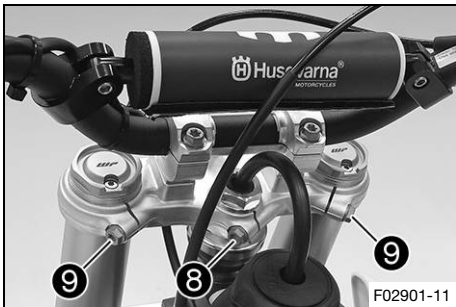

- Tighten screw **8**.

Guideline

Screw, top triple clamp	M8	20 Nm (14.8 lbf ft)
-------------------------	----	---------------------

- Using a plastic hammer, tap lightly on the upper triple clamp to avoid stresses.

- Tighten screws **9**.

Guideline

Screw, top triple clamp	M8	20 Nm (14.8 lbf ft)
-------------------------	----	---------------------

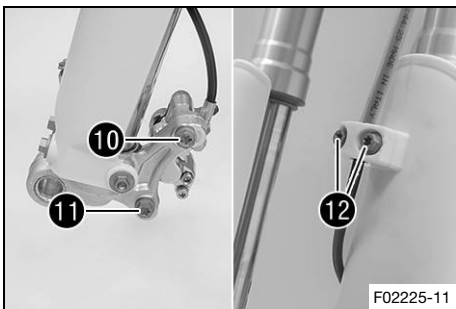

- Position the brake caliper, mount screw **10**, and tighten.

Guideline

Screw, front brake caliper	M8x60	20 Nm (14.8 lbf ft) <b>Loctite®243™</b>
----------------------------	-------	--

- Mount and tighten screw **11**.

Guideline

Screw, front brake caliper	M8x40	20 Nm (14.8 lbf ft) <b>Loctite®243™</b>
----------------------------	-------	--

- Position the brake line and the clamp. Mount and tighten screws **12**.

Guideline

Screw, brake line bracket	<b>EJOT</b>	1.7 Nm (1.25 lbf ft)
---------------------------	-------------	----------------------

### Finishing work

- Install front fender. (🔧 p. 55)
- Install the start number plate. (🔧 p. 54)
- Check that the wiring harness, throttle cables, and brake and clutch lines can move freely and are routed correctly.
- Install the front wheel. 🛠️ (🔧 p. 93)
- Check the steering head bearing play. (🔧 p. 50)
- Remove the motorcycle from the lift stand. (🔧 p. 41)

## 11.11 Checking the steering head bearing play



### Warning

**Danger of accidents** Incorrect steering head bearing play impairs the handling characteristic and damages components.

- Correct incorrect steering head bearing play immediately. (Your authorized Husqvarna Motorcycles workshop will be glad to help.)



### Info

If the vehicle is operated for a lengthy period with play in the steering head bearing, the bearings and the bearing seats in the frame can become damaged over time.

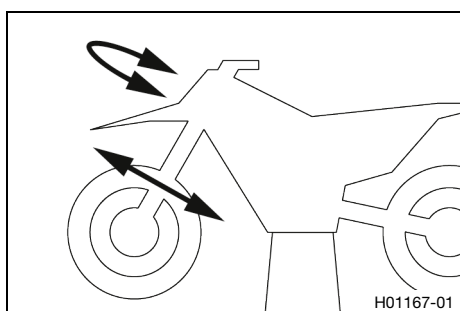

### Preparatory work

- Raise the motorcycle with a lift stand. (📖 p. 41)

### Main work

- Move the handlebar to the straight-ahead position. Move the fork legs to and fro in the direction of travel.

Play should not be detectable on the steering head bearing.

- » If there is detectable play:
  - Adjust the steering head bearing play. 🛠️ (📖 p. 50)

- Move the handlebar to and fro over the entire steering range.

It must be possible to move the handlebar easily over the entire steering range. There should be no detectable detent positions.

- » If detent positions are detected:
  - Adjust the steering head bearing play. 🛠️ (📖 p. 50)
  - Check the steering head bearing and replace if required.

### Finishing work

- Remove the motorcycle from the lift stand. (📖 p. 41)

## 11.12 Adjusting the steering head bearing play 🛠️

### Preparatory work

- Raise the motorcycle with a lift stand. (📖 p. 41)

### Main work

(TC 50)

- Pull fuel tank breather ① out of the steering stem.
- Loosen screws ②.
- Loosen screw ③.
- Loosen and retighten nut ④.

#### Guideline

Nut, steering head	M20x1.5	10 Nm (7.4 lbf ft)
--------------------	---------	--------------------

- Using a plastic hammer, tap lightly on the upper triple clamp to avoid stresses.
- Tighten screw ③.



Guideline

Screw, top triple clamp	M8	20 Nm (14.8 lbf ft)
-------------------------	----	---------------------

- Tighten screws ②.

Guideline

Screw, top triple clamp	M8	20 Nm (14.8 lbf ft)
-------------------------	----	---------------------

- Position the fuel tank breather ① in the steering stem.



### (TC 50 MINI)

- Pull fuel tank breather ① out of the steering stem.
- Loosen screws ②.
- Loosen screw ③.
- Loosen and retighten nut ④.

Guideline

Nut, steering head	M20x1.5	10 Nm (7.4 lbf ft)
--------------------	---------	--------------------

- Using a plastic hammer, tap lightly on the upper triple clamp to avoid stresses.
- Tighten screw ③.

Guideline

Screw, top triple clamp	M8	20 Nm (14.8 lbf ft)
-------------------------	----	---------------------

- Tighten screws ②.

Guideline

Screw, top triple clamp	M8	20 Nm (14.8 lbf ft)
-------------------------	----	---------------------

- Position the fuel tank breather ① in the steering stem.

### Finishing work

- Check the steering head bearing play. (📖 p. 50)
- Remove the motorcycle from the lift stand. (📖 p. 41)



## 11.13 Lubricating the steering head bearing 🛠️

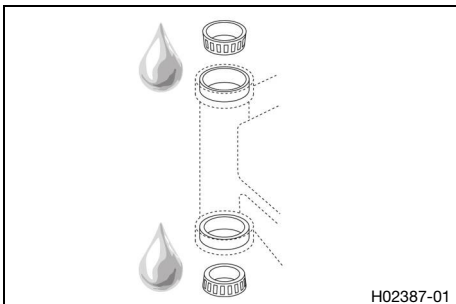

- Remove the lower triple clamp. 🛠️ (📖 p. 46)
- Install the lower triple clamp. 🛠️ (📖 p. 47)



### Info

The steering head bearing is cleaned and lubricated in the course of removal and installation of the lower triple clamp.



## 11.14 Removing the fuel tank ↩



### Danger

**Fire hazard** Fuel is highly flammable.

The fuel in the fuel tank expands when warm and can escape if overfilled.

- Do not fuel the vehicle in the vicinity of open flames or lit cigarettes.
- Switch off the engine for refueling.
- Make sure that no fuel is spilled; particularly not on hot parts of the vehicle.
- If any fuel is spilled, wipe it off immediately.
- Observe the specifications for refueling.



### Warning

**Danger of poisoning** Fuel is poisonous and a health hazard.

- Avoid skin, eye and clothing contact with fuel.
- Immediately consult a doctor if you swallow fuel.
- Do not inhale fuel vapors.
- In case of skin contact, rinse the affected area with plenty of water.
- Rinse the eyes thoroughly with water, and consult a doctor in case of fuel contact with the eyes.
- Change your clothing in case of fuel spills on them.
- Keep fuels correctly in a suitable canister, and out of the reach of children.

### Preparatory work

- Remove the seat. (📖 p. 61)
- Remove the left side cover. (📖 p. 57)
- Remove the right side cover. (📖 p. 55)
- Turn the knurled screw on the fuel tap all the way clockwise.

### Main work

- Remove screw ❶.

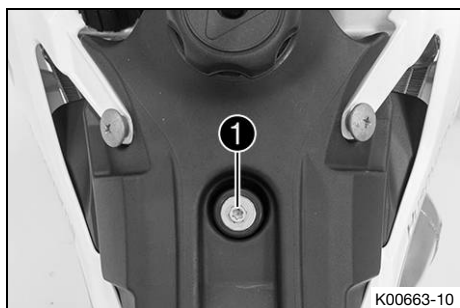

- Raise the fuel tank.
- Pull off fuel hose ❷.



### Info

Remaining fuel may flow out of the fuel hose.

- Pull fuel tank breather out of the steering stem.
- Take off the fuel tank.

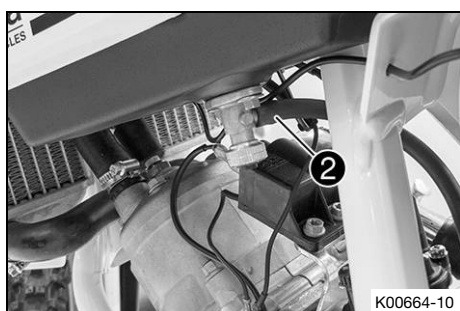

## 11.15 Installing the fuel tank ↩



### Danger

**Fire hazard** Fuel is highly flammable.

The fuel in the fuel tank expands when warm and can escape if overfilled.

- Do not fuel the vehicle in the vicinity of open flames or lit cigarettes.
- Switch off the engine for refueling.
- Make sure that no fuel is spilled; particularly not on hot parts of the vehicle.
- If any fuel is spilled, wipe it off immediately.
- Observe the specifications for refueling.



### Warning

**Danger of poisoning** Fuel is poisonous and a health hazard.

- Avoid skin, eye and clothing contact with fuel.
- Immediately consult a doctor if you swallow fuel.
- Do not inhale fuel vapors.
- In case of skin contact, rinse the affected area with plenty of water.
- Rinse the eyes thoroughly with water, and consult a doctor in case of fuel contact with the eyes.
- Change your clothing in case of fuel spills on them.
- Keep fuels correctly in a suitable canister, and out of the reach of children.

### Main work

- Check the throttle cable routing. (📖 p. 74)
- Mount fuel hose ①.

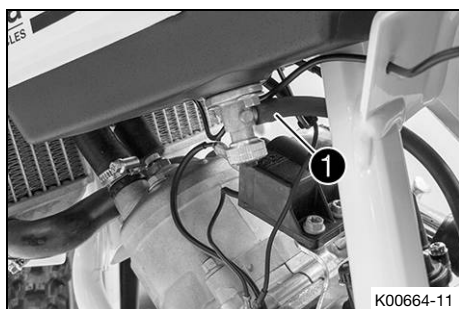

- Position the fuel tank.
- Make sure that no cables or throttle cables are trapped or damaged.
- Mount and tighten screw ②.

### Guideline

Remaining screws, chassis	M6	10 Nm (7.4 lbf ft)
---------------------------	----	--------------------

- Position the fuel tank breather in the steering stem.



### Finishing work

- Install the left side cover. (📖 p. 58)
- Install the right side cover. (📖 p. 56)
- Mount the seat. (📖 p. 61)



## 11.16 Removing the start number plate

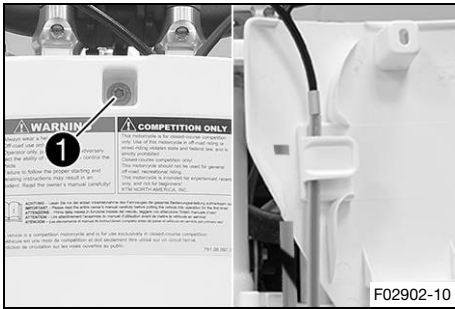

- Remove screw ❶.
- Unhook the start number plate from the brake line and remove it.

## 11.17 Installing the start number plate

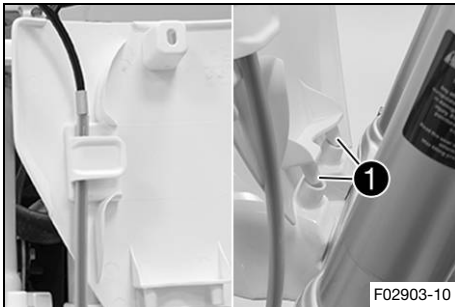

- Attach the start number plate to the brake line.
- Position the start number plate.
- ✓ Holding lugs ❶ engage in the fender.

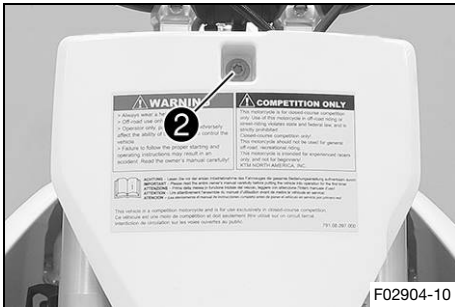

- Mount and tighten screw ❷.

Guideline

Screw, start number plate	M6	4 Nm (3 lbf ft)
---------------------------	----	-----------------

## 11.18 Removing front fender

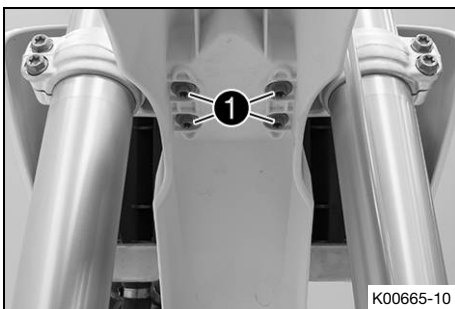

- Remove screws ❶. Take off the front fender.



## 11.19 Installing front fender

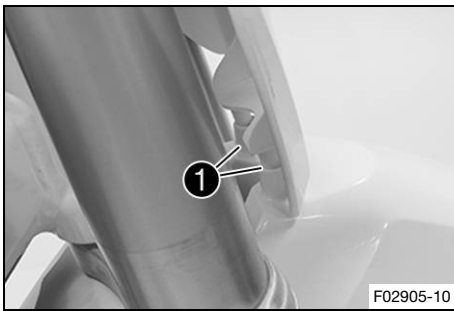

- Position the fender with drill holes **1** in the holding lugs on the start number plate.

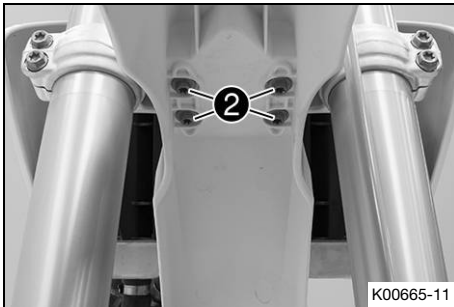

- Position front fender. Mount and tighten screws **2**.

### Guideline

Screw, fender	M6	6 Nm (4.4 lbf ft)
---------------	----	-------------------

## 11.20 Removing the right side cover

### Preparatory work

- Remove the seat. (📖 p. 61)

### Condition

Right side cover secured.

- Remove screw **1**.

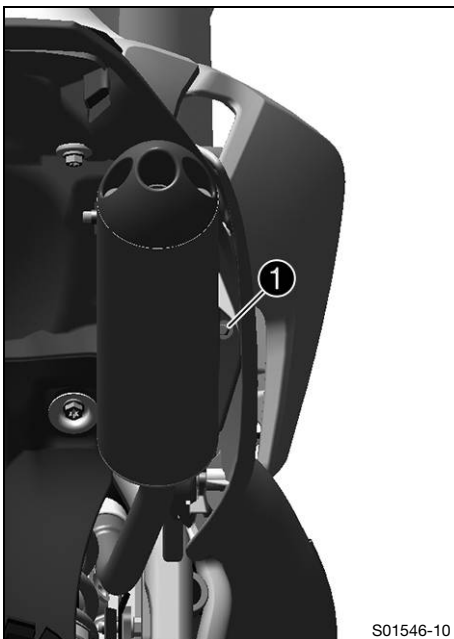

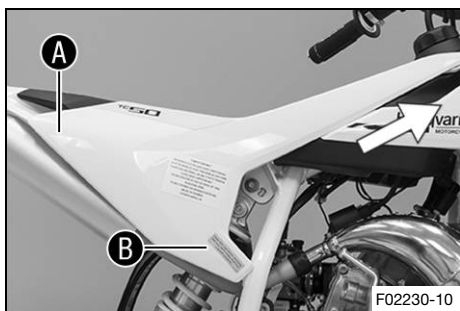

- Pull off the side cover sideways in areas **A** and **B**, and remove toward the front.

## 11.21 Installing the right side cover

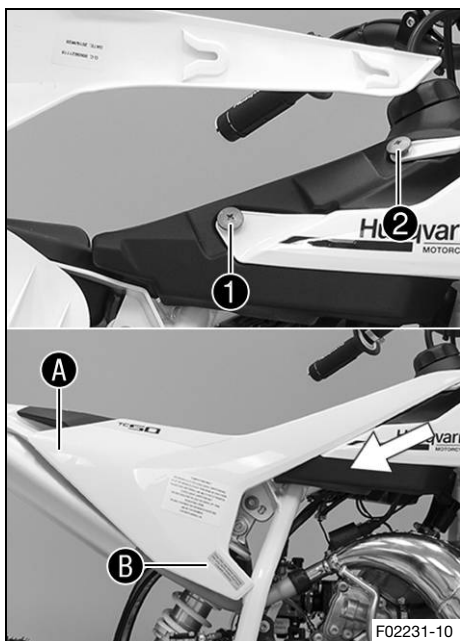

### Main work

- Position the side cover on collar bushings **1** and **2**, and push toward the rear.
- Engage the side cover in areas **A** and **B**.

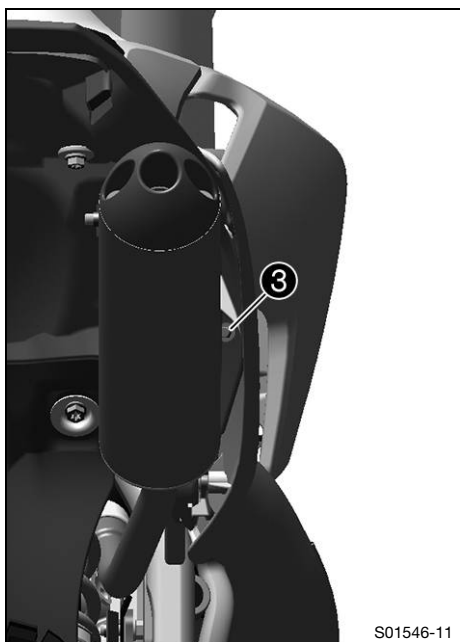

### Condition

Right side cover secured.

- Mount and tighten screw **3**.

### Guideline

Screw, side cover	<b>EJOT PT®</b> K60x20-Z	2 Nm (1.5 lbf ft)
-------------------	-----------------------------	-------------------

## Finishing work

- Mount the seat. (📖 p. 61)



## 11.22 Preparing the right side cover for securing 🔧

### Preparatory work

- Remove the seat. (📖 p. 61)
- Remove the right side cover. (📖 p. 55)

### Main work

- Drill a hole at marking **A**.

#### Guideline

Diameter	6.5 mm (0.256 in)
----------	-------------------

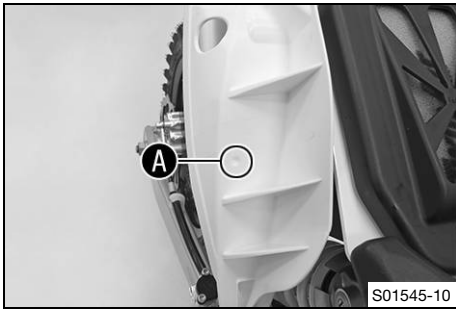

### Finishing work

- Install the right side cover. (📖 p. 56)
- Mount the seat. (📖 p. 61)



## 11.23 Removing the left side cover 🔧

### Preparatory work

- Remove the seat. (📖 p. 61)

### Condition

Left side cover secured.

- Remove screw **1**.

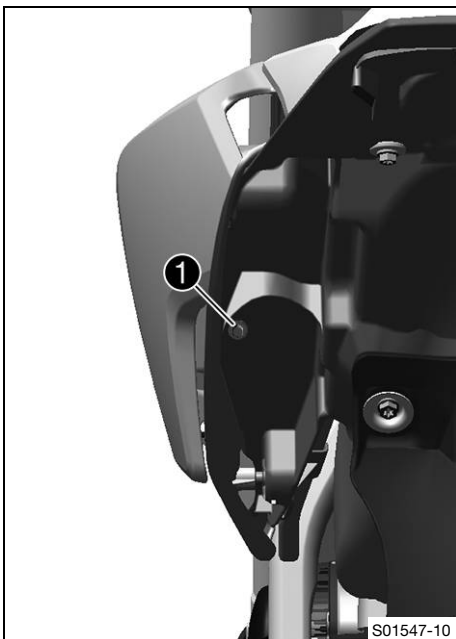

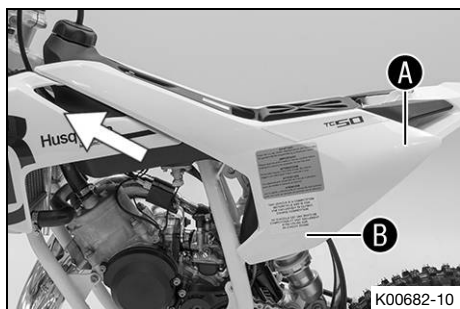

- Pull off the side cover sideways in areas **A** and **B**, and remove toward the front.

## 11.24 Installing the left side cover

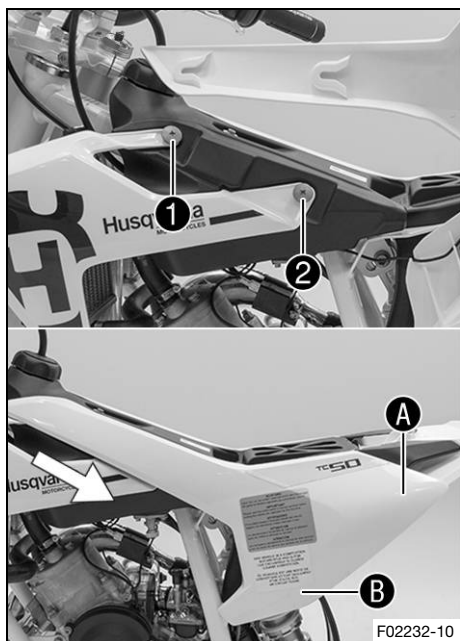

### Main work

- Position the side cover on collar bushings **1** and **2**, and push toward the rear.
- Engage the side cover in areas **A** and **B**.

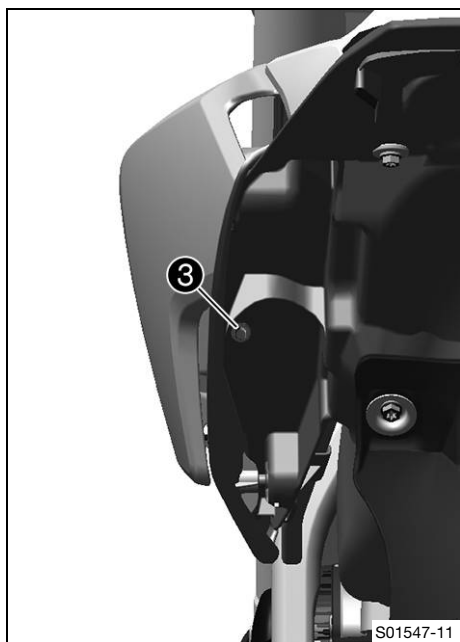

### Condition

Left side cover secured.

- Mount and tighten screw **3**.

### Guideline

Screw, side cover	<b>EJOT PT®</b> K60x20-Z	2 Nm (1.5 lbf ft)
-------------------	-----------------------------	-------------------

## Finishing work

- Mount the seat. (📖 p. 61)



## 11.25 Preparing the left side cover for securing 🛠️

### Preparatory work

- Remove the seat. (📖 p. 61)
- Remove the left side cover. (📖 p. 57)

### Main work

- Drill a hole at marking **A**.

#### Guideline

Diameter	6.5 mm (0.256 in)
----------	-------------------

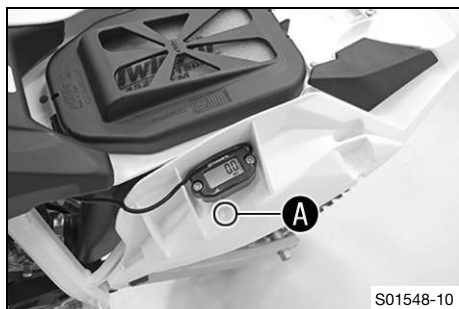

### Finishing work

- Install the left side cover. (📖 p. 58)
- Mount the seat. (📖 p. 61)



## 11.26 Removing the shock absorber 🛠️

### Preparatory work

#### (TC 50)

- Raise the motorcycle with a lift stand. (📖 p. 41)

#### (TC 50 MINI)

- Raise the motorcycle with a lift stand. (📖 p. 41)
- Remove the rear wheel. 🛠️ (📖 p. 94)

### Main work

#### (TC 50)

- Pull brake line **1** out of the holder.
- Remove nut **2**.
- Remove screw **3** and lower the link fork carefully.

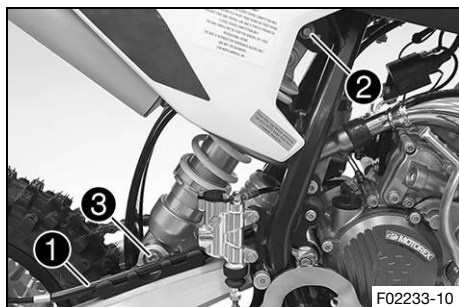

- Remove screw **4**, push splash protector **5** to the side, and remove the shock absorber.

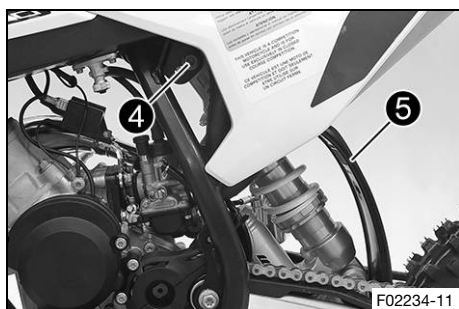

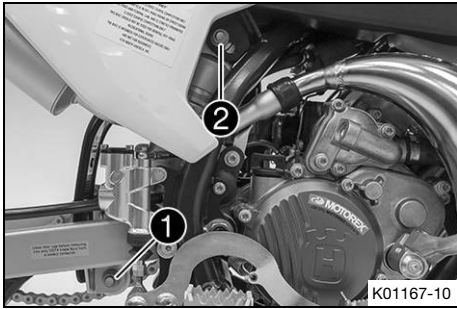

**(TC 50 MINI)**

- Remove nut 1 and 2.

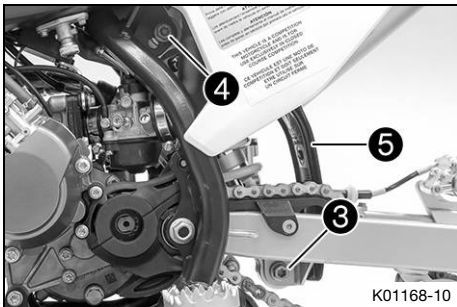

- Remove screw 3 and lower the link fork carefully.
- Remove screw 4, push splash protector 5 to the side, and remove the shock absorber.

## 11.27 Installing the shock absorber



**Warning**

**Danger of accidents** Modifications to the suspension setting may seriously alter the handling characteristic.

- Make sure your child rides slowly to start with after making adjustments in order that he or she can assess the new handling characteristic.

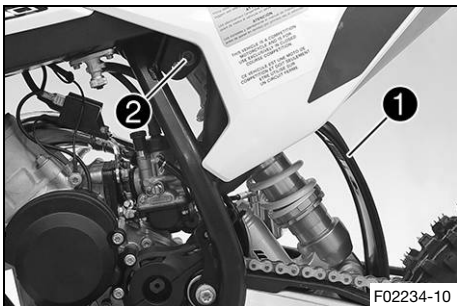

**Main work  
(TC 50)**

- Push splash protector 1 to the side.
- Position the shock absorber with screw 2, depending on the desired seating height.

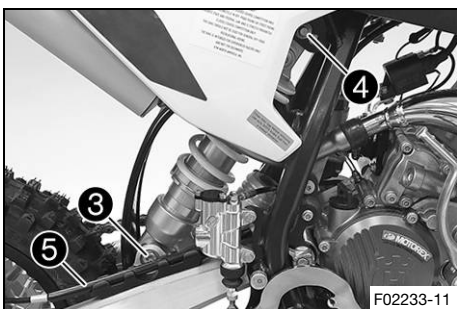

- Raise the link fork, mount and tighten the shock absorber with screw 3.

Guideline

Screw, bottom shock absorber	M10	45 Nm (33.2 lbf ft) <b>Loctite®243™</b>
------------------------------	-----	--

- Mount nut 4 and tighten the fitting.

Guideline

Screw, top shock absorber	M10	45 Nm (33.2 lbf ft) <b>Loctite®243™</b>
---------------------------	-----	--

- Attach brake line 5 to the holder.

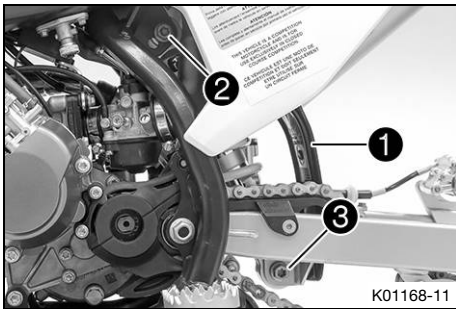

### (TC 50 MINI)

- Push splash protector **1** to the side.
- Position the shock absorber with screw **2**, depending on the desired seating height.
- Raise the link fork; position the shock absorber with screw **3**.

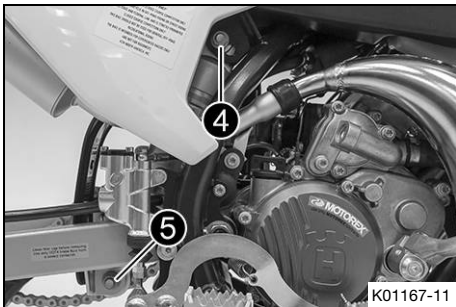

- Mount nut **4** and tighten the fitting.

#### Guideline

Screw, top shock absorber	M10	45 Nm (33.2 lbf ft) <b>Loctite®243™</b>
---------------------------	-----	--

- Mount nut **5** and tighten the fitting.

#### Guideline

Screw, bot- tom shock absorber	M10	45 Nm (33.2 lbf ft) <b>Loctite®243™</b>
--------------------------------------	-----	--

- Install the rear wheel. 🛠️ (p. 96)

### Finishing work

- Remove the motorcycle from the lift stand. 🛠️ (p. 41)

## 11.28 Removing the seat

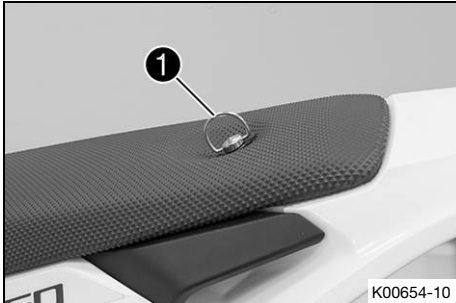

- Open quick release **1** and raise the rear of the seat.
- Pull back the seat and remove it.

## 11.29 Mounting the seat

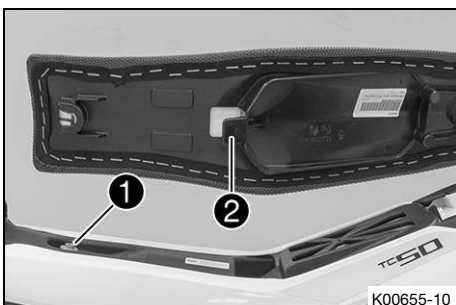

- Hook the seat onto screw **1**, lower the seat at the rear, and push it forward.
- ✓ Holding lug **2** hooks into the fuel tank.

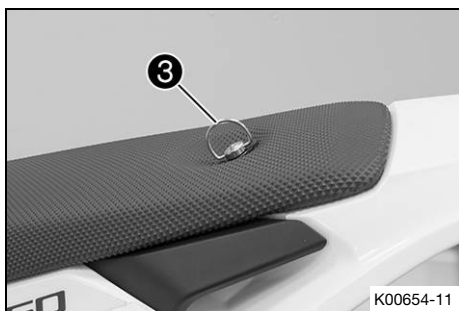

- Close quick release ③.

## 11.30 Removing the air filter ↶

### Note

**Engine damage** Unfiltered intake air has a negative effect on the service life of the engine. Dust and dirt will enter the engine without an air filter.

- Never start to use the vehicle without an air filter.



### Note

**Environmental hazard** Hazardous substances cause environmental damage.

- Dispose of oils, grease, filters, fuel, cleaning agents, brake fluid, etc., correctly and in compliance with the applicable regulations.

### Preparatory work

- Remove the seat. (📖 p. 61)

### Main work

- Press rear holding lug ① together slightly and swing the air filter box cover upward.
- Pull out the front holding lug and take off the air filter box cover.
- Take off the air filter.



## 11.31 Installing the air filter ↶

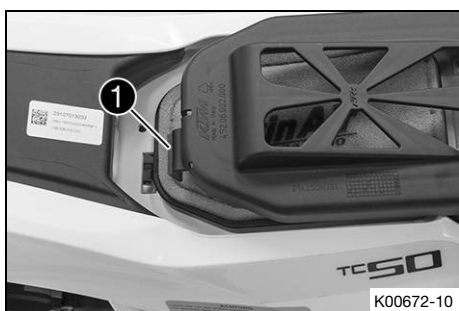

### Main work

- Position the clean air filter.
- Position the rear holding lug. Lower the air filter box cover and allow the front holding lug ① to snap in.



### Info

If the air filter is not mounted correctly, dust and dirt may enter the engine and result in damage.

### Finishing work

- Mount the seat. (📖 p. 61)



## 11.32 Cleaning the air filter and air filter box



### Note

**Environmental hazard** Hazardous substances cause environmental damage.

- Dispose of oils, grease, filters, fuel, cleaning agents, brake fluid, etc., correctly and in compliance with the applicable regulations.



### Info

Do not clean the air filter with fuel or petroleum since these substances attack the foam.

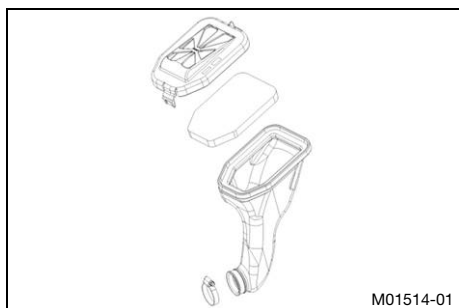

### Preparatory work

- Remove the seat. (📖 p. 61)
- Remove the air filter. (🔧📖 p. 62)

### Main work

- Wash the air filter thoroughly in special cleaning liquid and allow it to dry properly.

Air filter cleaner (📖 p. 139)



### Info

Only press the air filter to dry it, never wring it out.

- Oil the dry air filter with a high-grade air filter oil.

Oil for foam air filter (📖 p. 139)

- Clean the air filter box.
- Check intake flange for damage and looseness.

### Finishing work

- Install the air filter. (🔧📖 p. 62)
- Mount the seat. (📖 p. 61)



## 11.33 Removing the main silencer



### Warning

**Danger of burns** The exhaust system gets very hot when the vehicle is driven.

- Allow the exhaust system to cool down before performing any work on the vehicle.

### Preparatory work

- Remove the seat. (📖 p. 61)
- Remove the right side cover. (📖 p. 55)

### Main work

- Remove screw ①.
- Remove screw ②.
- Pull off the main silencer from the manifold at sleeve ③.

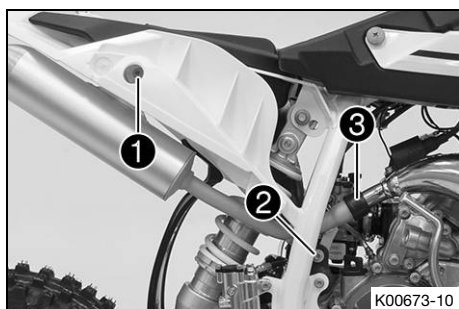

## 11.34 Installing the main silencer

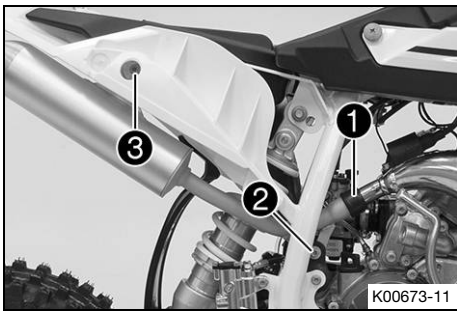

### Main work

- Position main silencer.
- Mount the main silencer with sleeve ①.
- Mount the silent block with screw ②.

#### Guideline

Remaining screws, chassis	M6	10 Nm (7.4 lbf ft)
---------------------------	----	--------------------

- Position the collar bushings.
- Mount and tighten screw ③.

#### Guideline

Remaining screws, chassis	M6	10 Nm (7.4 lbf ft)
---------------------------	----	--------------------

### Finishing work

- Install the right side cover. (📖 p. 56)
- Mount the seat. (📖 p. 61)

## 11.35 Changing the glass fiber yarn filling of the main silencer



### Warning

**Danger of burns** The exhaust system gets very hot when the vehicle is driven.

- Allow the exhaust system to cool down before performing any work on the vehicle.



### Info

Over time, the fibers of the insulating material vanish into the air, and the silencer "burns out". Not only is the noise level higher, the performance characteristic changes.

### Preparatory work

- Remove the seat. (📖 p. 61)
- Remove the right side cover. (📖 p. 55)
- Remove the main silencer. (📖 p. 63)

### Main work

- Remove screws with toothed washers ① from the silencer cap ②.
- Remove end cap and outer tube ③.
- Remove glass fiber yarn filling ④ from the inner tube.
- Clean the parts that need to be reinstalled and check for damage.
- Mount the new glass fiber yarn filling on the inner tube.
- Slide the outer tube over the glass fiber yarn filling.
- Insert the end cap into the outer tube.
- Mount and tighten the screws with the toothed washers.

#### Guideline

Remaining screws, chassis	M6	10 Nm (7.4 lbf ft)
---------------------------	----	--------------------

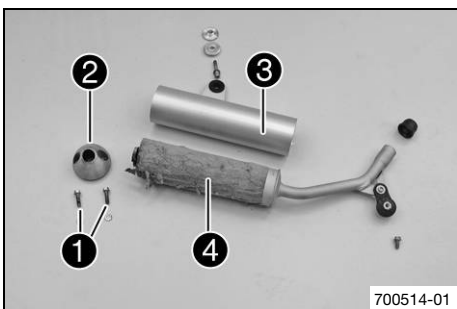

## Finishing work

- Install the main silencer. (📖 p. 64)
- Install the right side cover. (📖 p. 56)
- Mount the seat. (📖 p. 61)



## 11.36 Removing the engine sprocket cover

### Preparatory work

- Raise the motorcycle with a lift stand. (📖 p. 41)

### Main work

#### (TC 50)

- Remove screws ❶.
- Remove screw ❷.
- Take off the engine sprocket cover.

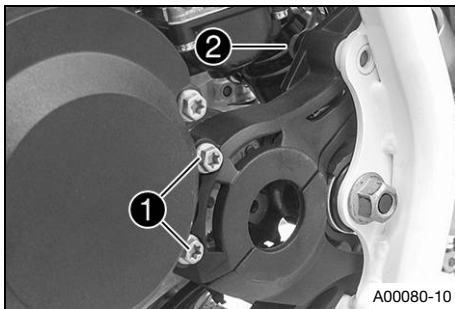

A00080-10

#### (TC 50 MINI)

- Remove screws ❶.
- Remove screw ❷.
- Take off the engine sprocket cover.

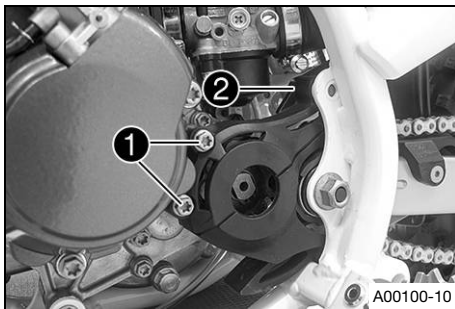

A00100-10



## 11.37 Installing the engine sprocket cover

### Main work

#### (TC 50)

- Position the engine sprocket cover. Mount screws ❶ but do not tighten yet.
- Mount and tighten screw ❷.

#### Guideline

Screw, engine sprocket cover	M8	15 Nm (11.1 lbf ft)
------------------------------	----	---------------------

- Tighten screws ❶.

#### Guideline

Screw, engine sprocket cover	M8	15 Nm (11.1 lbf ft)
------------------------------	----	---------------------

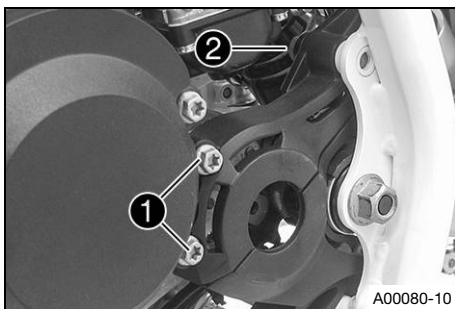

A00080-10

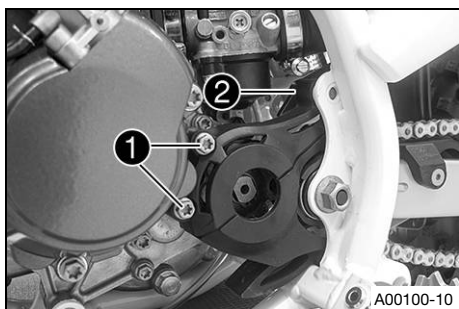

## (TC 50 MINI)

- Position the engine sprocket cover. Mount screws **1** but do not tighten yet.
- Mount and tighten screw **2**.

### Guideline

Screw, engine sprocket cover	M8	15 Nm (11.1 lbf ft)
------------------------------	----	---------------------

- Tighten screws **1**.

### Guideline

Screw, engine sprocket cover	M8	15 Nm (11.1 lbf ft)
------------------------------	----	---------------------

## Finishing work

- Remove the motorcycle from the lift stand. (📖 p. 41)

## 11.38 Checking the chain for dirt

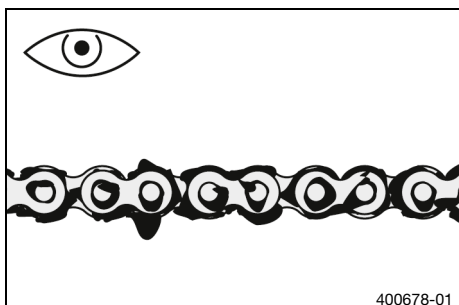

- Check the chain for coarse dirt accumulation.
  - » If the chain is very dirty:
    - Clean the chain. (📖 p. 66)

## 11.39 Cleaning the chain



### Warning

**Danger of accidents** Lubricants on the tires reduces the road grip.

- Remove lubricants from the tires using a suitable cleaning agent.



### Warning

**Danger of accidents** Oil or grease on the brake discs reduces the braking effect.

- Always keep the brake discs free of oil and grease.
- Clean the brake discs with brake cleaner when necessary.



### Note

**Environmental hazard** Hazardous substances cause environmental damage.

- Dispose of oils, grease, filters, fuel, cleaning agents, brake fluid, etc., correctly and in compliance with the applicable regulations.



### Info

The service life of the chain depends largely on its maintenance.

## Preparatory work

- Raise the motorcycle with a lift stand. (📖 p. 41)

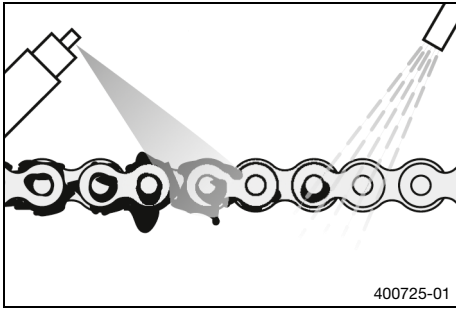

400725-01

### Main work

- Rinse off loose dirt with a soft jet of water.
- Remove old grease residue with chain cleaner.

Chain cleaner (📖 p. 139)
--------------------------

- After drying, apply chain spray.

Off-road chain spray (📖 p. 139)
---------------------------------

### Finishing work

- Remove the motorcycle from the lift stand. (📖 p. 41)

## 11.40 Checking the chain tension

### Warning

**Danger of accidents** Incorrect chain tension damages components and results in accidents.

If the chain is tensioned too much, the chain, engine sprocket, rear sprocket, transmission and rear wheel bearings wear more quickly. Some components may break if overloaded.

If the chain is too loose, the chain may fall off the engine sprocket or the rear sprocket. As a result, the rear wheel locks or the engine will be damaged.

- Check the chain tension regularly.
- Set the chain tension in accordance with the specification.

### Preparatory work

- Raise the motorcycle with a lift stand. (📖 p. 41)

### Main work (TC 50)

- Press the chain upward at the end of the chain sliding piece and determine chain tension **A**.

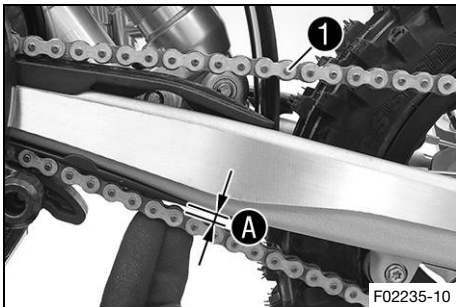

F02235-10

### Info

The top part of chain **1** must be taut. Chain wear is not always even, so you should repeat this measurement at different chain positions.

Chain tension	5 ... 8 mm (0.2 ... 0.31 in)
---------------	------------------------------

- » If the chain tension does not meet the specification:
  - Adjust the chain tension. (📖 p. 68)

### (TC 50 MINI)

- Press the chain upward at the end of the chain sliding piece and determine chain tension **A**.

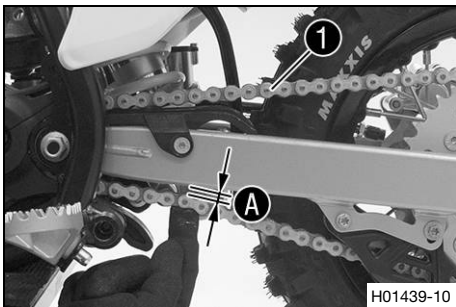

H01439-10

### Info

The top part of chain **1** must be taut. Chain wear is not always even, so you should repeat this measurement at different chain positions.

Chain tension	5 ... 8 mm (0.2 ... 0.31 in)
---------------	------------------------------

- » If the chain tension does not meet the specification:
  - Adjust the chain tension. (📖 p. 68)

### Finishing work

- Remove the motorcycle from the lift stand. (📖 p. 41)

## 11.41 Adjusting the chain tension



### Warning

**Danger of accidents** Incorrect chain tension damages components and results in accidents.

If the chain is tensioned too much, the chain, engine sprocket, rear sprocket, transmission and rear wheel bearings wear more quickly. Some components may break if overloaded.

If the chain is too loose, the chain may fall off the engine sprocket or the rear sprocket. As a result, the rear wheel locks or the engine will be damaged.

- Check the chain tension regularly.
- Set the chain tension in accordance with the specification.

### Preparatory work

- Raise the motorcycle with a lift stand. (📖 p. 41)
- Check the chain tension. (📖 p. 67)

### Main work (TC 50)

- Loosen nut ❶.
- Loosen nuts ❷.
- Adjust the chain tension by turning adjusting screws ❸ left and right.

#### Guideline

Chain tension	5 ... 8 mm (0.2 ... 0.31 in)
---------------	------------------------------

Turn the adjusting screws ❸ on the left and right so that the markings on the left and right chain adjusters ❹ are in the same position relative to the reference marks A. The rear wheel is then correctly aligned.

- Tighten nuts ❷.
- Make sure that chain adjusters ❹ are fitted correctly on adjusting screws ❸.
- Tighten nut ❶.

#### Guideline

Nut, rear wheel spindle	M12x1	40 Nm (29.5 lbf ft)
-------------------------	-------	---------------------

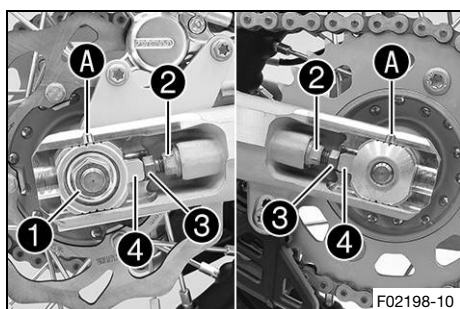

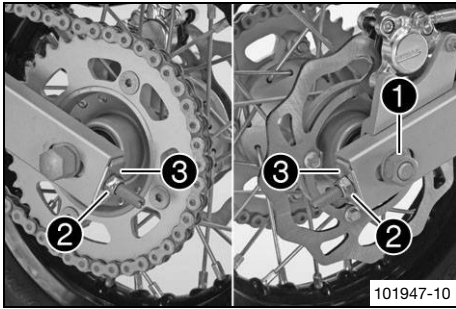

## (TC 50 MINI)

- Loosen nut ①.
- Adjust the chain tension by turning adjusting nuts ② left and right.

### Guideline

Chain tension	5 ... 8 mm (0.2 ... 0.31 in)
Turn adjusting nuts ② equally on the left and right. The rear wheel must be aligned with the front wheel.	

- Make sure that the chain adjuster support plates ③ are in contact with adjusting nuts ②.
- Tighten nut ①.

### Guideline

Nut, rear wheel spindle	M12x1	40 Nm (29.5 lbf ft)
-------------------------	-------	---------------------

## Finishing work

- Remove the motorcycle from the lift stand. (📖 p. 41)

## 11.42 Checking the chain, rear sprocket, engine sprocket, and chain guide

### Preparatory work

- Raise the motorcycle with a lift stand. (📖 p. 41)
- Remove the engine sprocket cover. (📖 p. 65)

### Main work

- Check the engine sprocket cover for wear.
  - » If the engine sprocket cover is worn through in the marked area A:
  - Change the engine sprocket cover. 🛠️

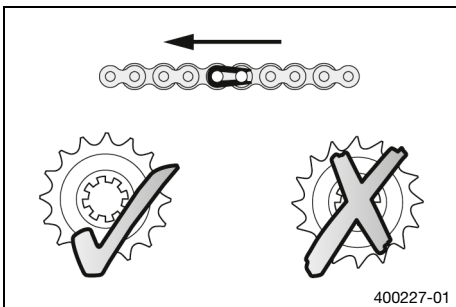
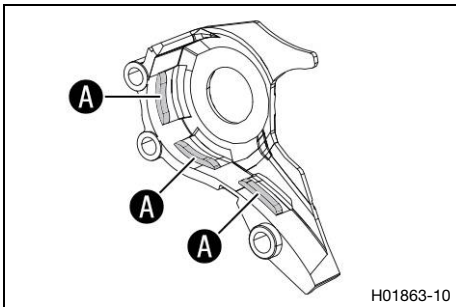

- Check the rear sprocket and the engine sprocket for wear.
  - » If the rear sprocket or engine sprocket is worn:
  - Change the drivetrain kit. 🛠️

### **i** Info

The engine sprocket, rear sprocket, and chain should always be replaced together. When fitting the chain joint, always make sure that the closed side of the joint faces forward (riding direction).

- Check the chain for wear.
  - » If the chain is worn:
  - Change the drivetrain kit. 🛠️



## Info

When a new chain is mounted, the rear sprocket and engine sprocket should also be changed.  
New chains wear out faster on old, worn sprockets.

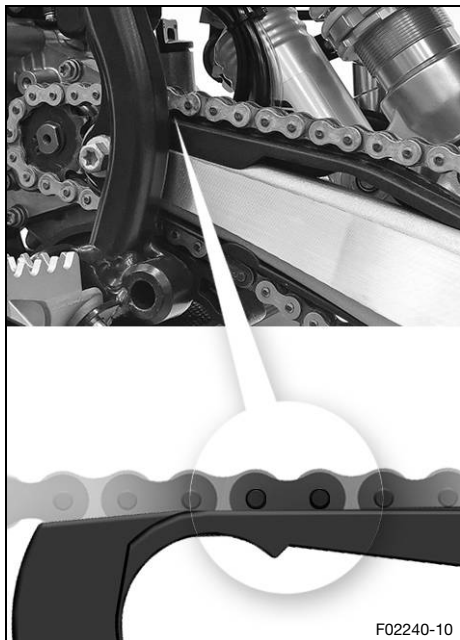

F02240-10

### (TC 50)

- Check the chain sliding guard for wear.
  - » If the ridge is worn down to the level of the main corpus:
    - Change the chain sliding guard. 🛠️
- Check that the chain sliding guard is firmly seated.
  - » If the chain sliding guard is loose:
    - Tighten the screw of the chain sliding guard.

#### Guideline

Screw, chain sliding piece	M6	3 Nm (2.2 lbf ft)
----------------------------	----	-------------------

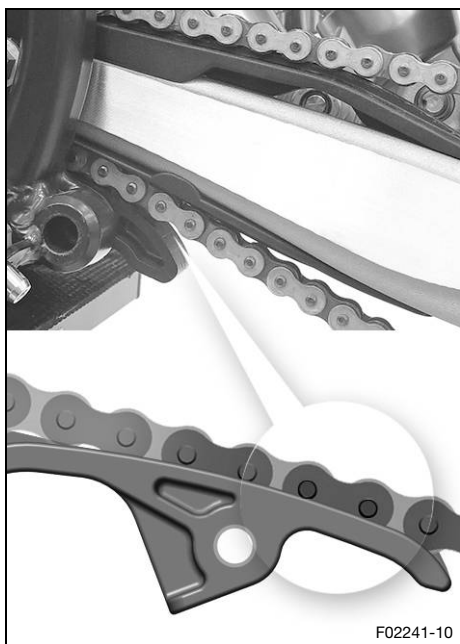

F02241-10

- Check the chain sliding piece for wear.
  - » If the lower edge of the chain pins is in line with or below the chain sliding piece:
    - Change the chain sliding piece. 🛠️
- Check that the chain sliding piece is firmly seated.
  - » If the chain sliding piece is loose:
    - Tighten screw on the chain sliding piece.

#### Guideline

Screw, chain sliding piece	M8	15 Nm (11.1 lbf ft)
----------------------------	----	---------------------



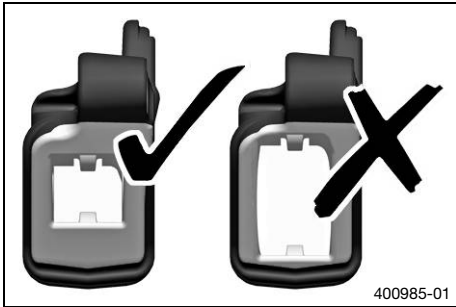

- Check the chain guide for wear.



**Info**

Wear can be seen on the front of the chain guide.

- » If the light part of the chain guide is worn:
  - Change the chain guide. 🛠️



- Check that the chain guide is firmly seated.
  - » If the chain guide is loose:
    - Tighten the screws on the chain guide.

Guideline

Remaining screws, chassis	M6	10 Nm (7.4 lbf ft)
---------------------------	----	-----------------------

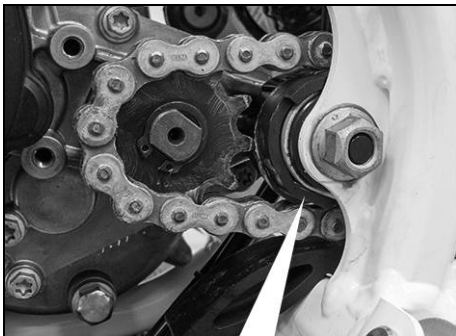

**(TC 50 MINI)**

- Check the chain sliding guard for wear.
  - » If the ridge is worn down to the level of the main corpus:
    - Change the chain sliding guard. 🛠️
- Check that the chain sliding guard is firmly seated.
  - » If the chain sliding guard is loose:
    - Tighten the screw of the chain sliding guard.

Guideline

Screw, chain sliding piece	M6	3 Nm (2.2 lbf ft)
----------------------------	----	-------------------

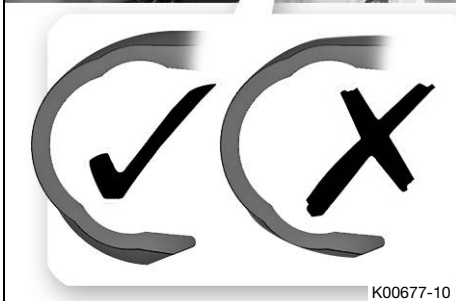

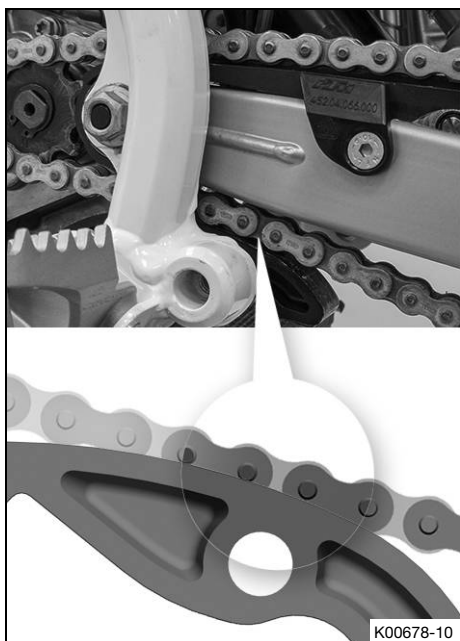

K00678-10

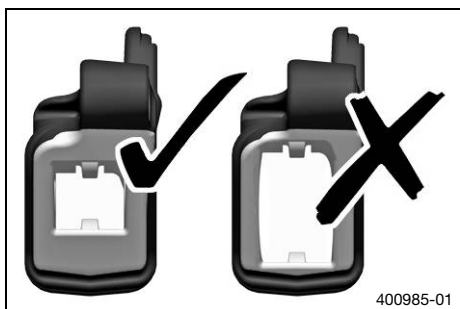

400985-01



H00095-01

- Check the chain sliding piece for wear.
  - » If the lower edge of the chain pins is in line with or below the chain sliding piece:
    - Change the chain sliding piece. 🛠️
- Check that the chain sliding piece is firmly seated.
  - » If the chain sliding piece is loose:
    - Tighten screw on the chain sliding piece.

Guideline

Screw, chain sliding piece	M8	15 Nm (11.1 lbf ft)
----------------------------	----	------------------------

- Check the chain guide for wear.

---

**i Info**  
Wear can be seen on the front of the chain guide.

---

- » If the light part of the chain guide is worn:
  - Change the chain guide. 🛠️
- Check that the chain guide is firmly seated.
  - » If the chain guide is loose:
    - Tighten the screws on the chain guide.

Guideline

Remaining screws, chassis	M6	10 Nm (7.4 lbf ft)
---------------------------	----	-----------------------

**Finishing work**

- Install the engine sprocket cover. (📖 p. 65)
- Remove the motorcycle from the lift stand. (📖 p. 41)

## 11.43 Adjusting the chain guide ↘

### **i** Info

The size of the chain wheel varies with the number of teeth. The chain guide can be adjusted on small sprockets.



F02201-10

### (TC 50)

- Loosen screw ①.
- Position the chain guide.
- Tighten the screw.

#### Guideline

Remaining screws, chassis	M6	10 Nm (7.4 lbf ft)
---------------------------	----	--------------------

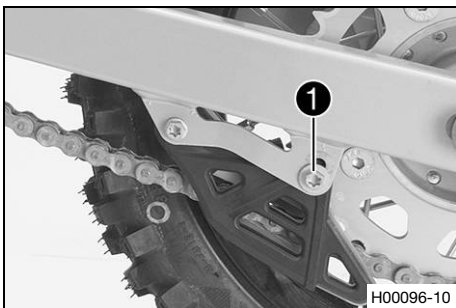

H00096-10

### (TC 50 MINI)

- Loosen screw ①.
- Position the chain guide.
- Tighten the screw.

#### Guideline

Remaining screws, chassis	M6	10 Nm (7.4 lbf ft)
---------------------------	----	--------------------

## 11.44 Checking the frame ↘

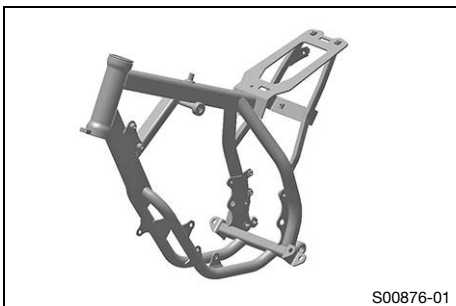

S00876-01

- Check the frame for cracks and deformation.
  - » If the frame exhibits cracks or deformation due to a mechanical impact:
    - Change the frame. ↘

### **i** Info

Always replace a frame that has been damaged due to a mechanical impact. Repair of the frame is not authorized by Husqvarna Motorcycles.

## 11.45 Checking the link fork ↘

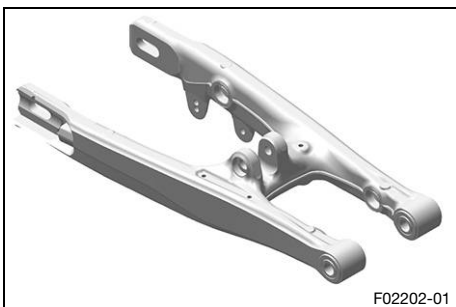

F02202-01

### (TC 50)

- Check the link fork for damage, cracking, and deformation.
  - » If the link fork shows signs of damage, cracking, or deformation:
    - Change the link fork. ↘

## **i** Info

Always replace a damaged link fork. Husqvarna Motorcycles does not permit repairing link forks.

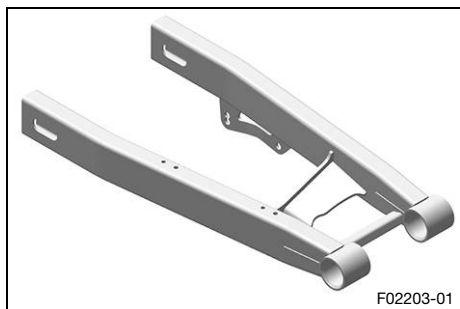

### (TC 50 MINI)

- Check the link fork for damage, cracking, and deformation.
  - » If the link fork shows signs of damage, cracking, or deformation:
    - Change the link fork. 🛠️

## **i** Info

Always replace a damaged link fork. Husqvarna Motorcycles does not permit repairing link forks.

## 11.46 Checking the throttle cable routing



### Warning

**Danger of accidents** The throttle cable may slip out of the guide if routed incorrectly. The throttle slide will then no longer be closed and the speed can no longer be controlled.

- Make sure that the throttle cable routing and the play in the throttle cable comply with the specification.

### Preparatory work

- Remove the seat. (📖 p. 61)
- Remove the left side cover. (📖 p. 57)
- Remove the right side cover. (📖 p. 55)
- Turn the knurled screw on the fuel tap all the way clockwise.
- Remove the fuel tank. 🛠️ (📖 p. 52)

### Main work

- Check the throttle cable routing.

The throttle cable must be routed to the carburetor behind the handlebars and above the fuel tank bracket.

- » If the throttle cable routing is not as specified:
  - Correct the throttle cable routing.

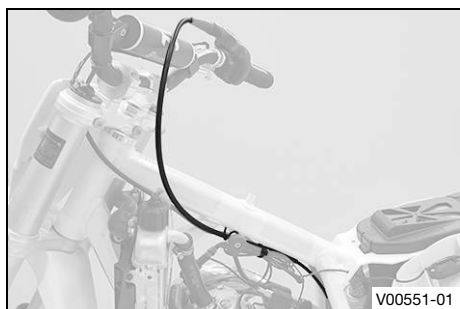

### Finishing work

- Install the fuel tank. 🛠️ (📖 p. 53)
- Install the left side cover. (📖 p. 58)
- Install the right side cover. (📖 p. 56)
- Mount the seat. (📖 p. 61)

## 11.47 Checking the rubber grip

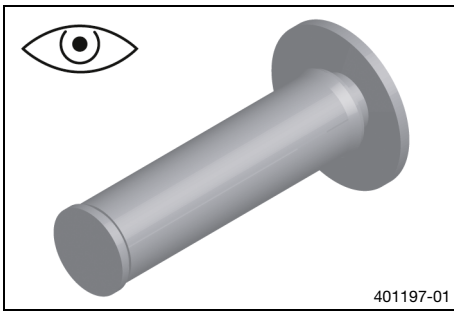

- Check the rubber grips on the handlebar for damage, wear, and looseness.
  - » If a rubber grip is damaged, worn, or loose:
    - Change the rubber grip.
 

Rubber grip adhesive (00062030051) (📖 p. 140)
---
    - Additionally secure the rubber grip. (📖 p. 75)



## 11.48 Additionally securing the rubber grip



### Preparatory work

- Check the rubber grip. (📖 p. 75)

### Main work

- Secure the rubber grip at two locations with the retaining wire.

Securing wire (54812016000)
Wire twister forceps (U6907854)

- ✓ The twisted wire ends face away from the palms and are bent in toward the rubber grip.



## 12.1 Checking play of handbrake lever



### Warning

**Danger of accidents** The brake system fails in the event of overheating.

If there is no free travel on the hand brake lever, pressure builds up on the front brake circuit.

- Set the free travel on the hand brake lever in accordance with the specification.

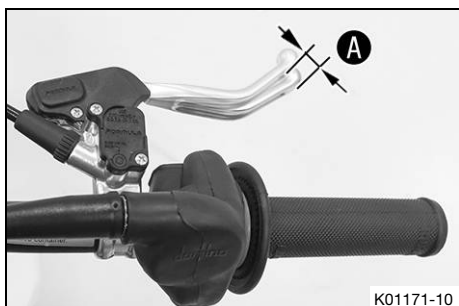

- Push the handbrake lever forwards and check play **A**.

Play of hand brake lever	3 ... 5 mm (0.12 ... 0.2 in)
--------------------------	------------------------------

- » If the play does not meet specifications:
  - Adjust the play of the hand brake lever. (📖 p. 76)

## 12.2 Adjusting the play of the hand brake lever

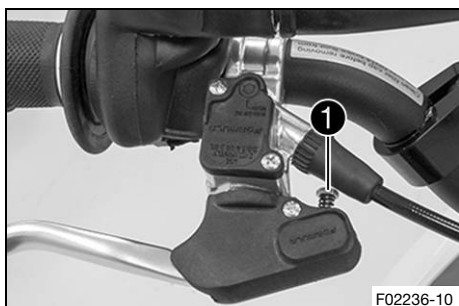

- Check the play of the handbrake lever. (📖 p. 76)
- Adjust the play of the hand brake lever using adjusting screw **1**.

Guideline

Play of hand brake lever	3 ... 5 mm (0.12 ... 0.2 in)
--------------------------	------------------------------

## 12.3 Adjusting the basic position of the hand brake lever

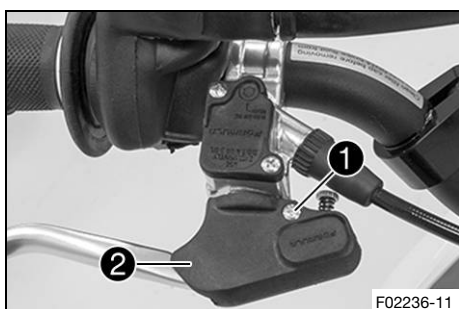

- Remove screw **1**. Take off cover **2**.

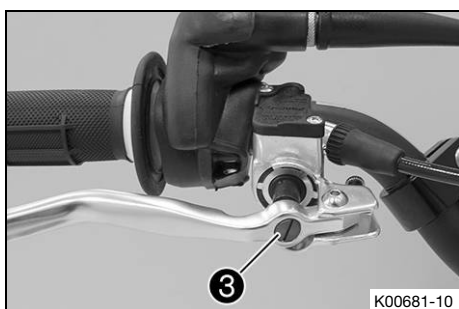

- Check the play of the handbrake lever. (📖 p. 76)
- Adjust the basic position of the hand brake lever with adjusting screw **3** to the rider's hand size.

**Info**

Turn the adjusting screw clockwise to increase the distance between the hand brake lever and the handlebar.

Turn the adjusting screw counterclockwise to decrease the distance between the hand brake lever and the handlebar.

The range of adjustment is limited.

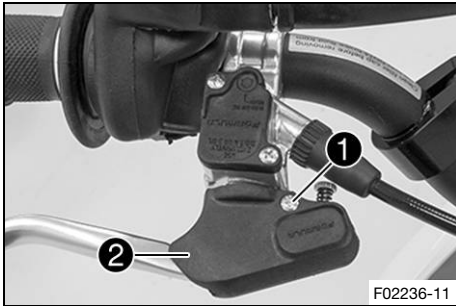

- Position cover **2**. Mount and tighten screw **1**.



## 12.4 Checking the brake discs

**Warning**

**Danger of accidents** Worn-out brake discs reduce the braking effect.

- Make sure that worn-out brake discs are replaced immediately. (Your authorized Husqvarna Motorcycles workshop will be glad to help.)

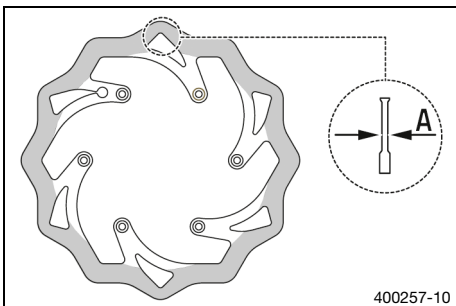

- Check the front and rear brake disc thickness at multiple points for the dimension **A**.

**Info**

Wear reduces the thickness of the brake disc around the contact surface of the brake linings.

Brake discs - wear limits	
front	2.2 mm (0.087 in)
rear	2.2 mm (0.087 in)

- » If the brake disc thickness is less than the specified value:
  - Change the front brake disc. 🛠️
  - Change the rear brake disc. 🛠️
- Check the front and rear brake discs for damage, cracking, and deformation.
  - » If the brake disc exhibits damage, cracking, or deformation:
    - Change the front brake disc. 🛠️
    - Change the rear brake disc. 🛠️



## 12.5 Checking the front brake fluid level



### Warning

**Danger of accidents** An insufficient brake fluid level will cause the brake system to fail.

If the brake fluid level drops below the specified marking or the specified value, the brake system is leaking or the brake linings are worn down.

- Check the brake system and do not continue riding until the problem is eliminated. (Your authorized Husqvarna Motorcycles workshop will be glad to help.)



### Warning

**Skin irritation** Brake fluid causes skin irritation.

- Keep brake fluid out of the reach of children.
- Wear suitable protective clothing and safety glasses.
- Do not allow brake fluid to come into contact with the skin, the eyes or clothing.
- Consult a doctor immediately if brake fluid has been swallowed.
- Rinse the affected area with plenty of water in the event of contact with the skin.
- Rinse eyes thoroughly with water immediately and consult a doctor if brake fluid comes into contact with the eyes.
- If brake fluid spills on to your clothing, change the clothing.



### Warning

**Danger of accidents** Old brake fluid reduces the braking effect.

- Make sure that brake fluid for the front and rear brake is changed in accordance with the service schedule. (Your authorized Husqvarna Motorcycles workshop will be glad to help.)



### Note

**Environmental hazard** Hazardous substances cause environmental damage.

- Dispose of oils, grease, filters, fuel, cleaning agents, brake fluid, etc., correctly and in compliance with the applicable regulations.



### Info

Never use DOT 5 brake fluid. It is silicone-based and purple in color. Oil seals and brake lines are not designed for DOT 5 brake fluid.

Avoid contact between brake fluid and painted parts. Brake fluid attacks paint.

Only use clean brake fluid from a sealed container.

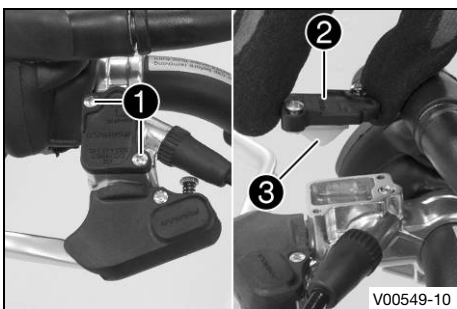

- Move the brake fluid reservoir mounted on the handlebar into a horizontal position.
- Remove screws ①.
- Take off cover ② with membrane ③.
- Check the brake fluid level.

Brake fluid level under top level of container	5 mm (0.2 in)
--	---------------

» If the brake fluid level does not meet specifications:

- Add the front brake fluid. 🛠️ (p. 79)
- Position the cover with the membrane. Mount and tighten the screws.



**Info**

Clean up the overflowed or spilled brake fluid immediately with water.



## 12.6 Adding the front brake fluid ↴

**Warning**

**Danger of accidents** An insufficient brake fluid level will cause the brake system to fail.

If the brake fluid level drops below the specified marking or the specified value, the brake system is leaking or the brake linings are worn down.

- Check the brake system and do not continue riding until the problem is eliminated. (Your authorized Husqvarna Motorcycles workshop will be glad to help.)

**Warning**

**Skin irritation** Brake fluid causes skin irritation.

- Keep brake fluid out of the reach of children.
- Wear suitable protective clothing and safety glasses.
- Do not allow brake fluid to come into contact with the skin, the eyes or clothing.
- Consult a doctor immediately if brake fluid has been swallowed.
- Rinse the affected area with plenty of water in the event of contact with the skin.
- Rinse eyes thoroughly with water immediately and consult a doctor if brake fluid comes into contact with the eyes.
- If brake fluid spills on to your clothing, change the clothing.

**Warning**

**Danger of accidents** Old brake fluid reduces the braking effect.

- Make sure that brake fluid for the front and rear brake is changed in accordance with the service schedule. (Your authorized Husqvarna Motorcycles workshop will be glad to help.)

**Note**

**Environmental hazard** Hazardous substances cause environmental damage.

- Dispose of oils, grease, filters, fuel, cleaning agents, brake fluid, etc., correctly and in compliance with the applicable regulations.

**Info**

Never use DOT 5 brake fluid. It is silicone-based and purple in color. Oil seals and brake lines are not designed for DOT 5 brake fluid.

Avoid contact between brake fluid and painted parts. Brake fluid attacks paint.

Only use clean brake fluid from a sealed container.

**Preparatory work**

- Check the front brake linings. (📖 p. 80)

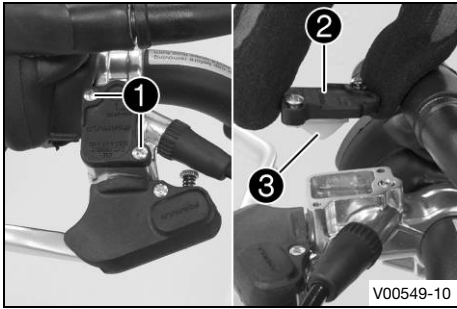

### Main work

- Move the brake fluid reservoir mounted on the handlebar into a horizontal position.
- Remove screws ①.
- Take off cover ② with membrane ③.
- Correct the brake fluid level.

### Guideline

Brake fluid level under top level of container	5 mm (0.2 in)
--	---------------

Brake fluid DOT 4 / DOT 5.1 (📖 p. 137)
--

- Position the cover with the membrane. Mount and tighten the screws.



### Info

Clean up the overflowed or spilled brake fluid immediately with water.

## 12.7 Checking the front brake linings



### Warning

**Danger of accidents** Worn-out brake linings reduce the braking effect.

- Ensure that worn-out brake linings are replaced immediately. (Your authorized Husqvarna Motorcycles workshop will be glad to help.)

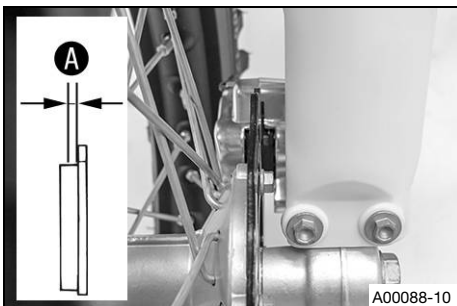

- Check the brake linings for minimum thickness A.

Minimum thickness A	≥ 1 mm (≥ 0.04 in)
---------------------	--------------------

- » If the minimum thickness is less than specified:
  - Change the brake linings of the front brake. 🛠️ (📖 p. 80)
- Check the brake linings for damage and cracking.
  - » If damage or wear is encountered:
    - Change the brake linings of the front brake. 🛠️ (📖 p. 80)

## 12.8 Changing the brake linings of the front brake 🛠️



### Warning

**Danger of accidents** Incorrect servicing will cause the brake system to fail.

- Ensure that service work and repairs are performed professionally. (Your authorized Husqvarna Motorcycles workshop will be glad to help.)

**Warning****Skin irritation** Brake fluid causes skin irritation.

- Keep brake fluid out of the reach of children.
- Wear suitable protective clothing and safety glasses.
- Do not allow brake fluid to come into contact with the skin, the eyes or clothing.
- Consult a doctor immediately if brake fluid has been swallowed.
- Rinse the affected area with plenty of water in the event of contact with the skin.
- Rinse eyes thoroughly with water immediately and consult a doctor if brake fluid comes into contact with the eyes.
- If brake fluid spills on to your clothing, change the clothing.

**Warning****Danger of accidents** Old brake fluid reduces the braking effect.

- Make sure that brake fluid for the front and rear brake is changed in accordance with the service schedule. (Your authorized Husqvarna Motorcycles workshop will be glad to help.)

**Warning****Danger of accidents** Brake linings which have not been approved alter the braking efficiency.

Not all brake linings are tested and approved for Husqvarna motorcycles. The structure and friction coefficient of the brake linings, and thus their brake power, may vary greatly from that of original brake linings.

If brake linings are used that differ from the original equipment, compliance with the original homologation is not guaranteed. In this case, the vehicle no longer corresponds to its condition at delivery and the manufacturer warranty shall be void.

- Only use brake linings approved and recommended by Husqvarna motorcycles.

**Note****Environmental hazard** Hazardous substances cause environmental damage.

- Dispose of oils, grease, filters, fuel, cleaning agents, brake fluid, etc., correctly and in compliance with the applicable regulations.

**Info**

Never use DOT 5 brake fluid. It is silicone-based and purple in color. Oil seals and brake lines are not designed for DOT 5 brake fluid.

Avoid contact between brake fluid and painted parts. Brake fluid attacks paint.

Only use clean brake fluid from a sealed container.

**Preparatory work**

- Raise the motorcycle with a lift stand. (📖 p. 41)

**Main work**

- Move the brake fluid reservoir mounted on the handlebar to a horizontal position.
- Remove screws ①.
- Take off cover ② with membrane ③.

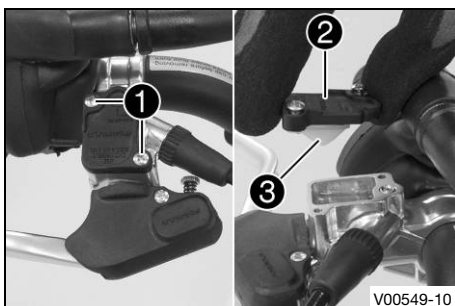

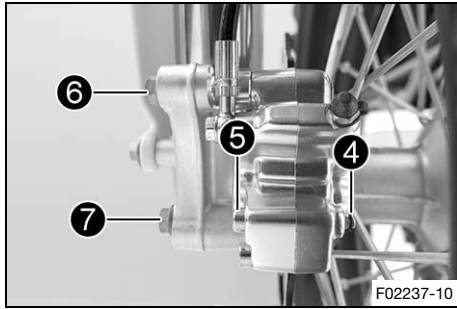

- Remove lock ring ④.
- Loosen screw ⑤.
- Remove screw ⑥ and ⑦.
- Press back the brake linings by slightly tilting the brake caliper laterally on the brake disc. Carefully pull the brake caliper backward from the brake disc.
- Remove screw ⑤.



### Warning

**Danger of accidents** Oil or grease on the brake discs reduces the braking effect.

- Always keep the brake discs free of oil and grease.
- Clean the brake discs with brake cleaner when necessary.



- Check the brake discs. (📖 p. 77)
- Remove the brake linings.
- Clean the brake caliper and the brake caliper bracket.
- Press the brake piston back into the basic position and ensure that brake fluid does not flow out of the brake fluid reservoir; extract some if necessary.



### Warning

**Danger of accidents** Brake linings which have not been approved alter the braking efficiency.

Not all brake linings are tested and approved for Husqvarna motorcycles. The structure and friction coefficient of the brake linings, and thus their brake power, may vary greatly from that of original brake linings.

If brake linings are used that differ from the original equipment, compliance with the original homologation is not guaranteed. In this case, the vehicle no longer corresponds to its condition at delivery and the manufacturer warranty shall be void.

- Only use brake linings approved and recommended by Husqvarna motorcycles.

- Position the new brake linings.



### Info

Always change the brake linings in pairs. Ensure that the brake linings are correctly positioned in the holding spring.

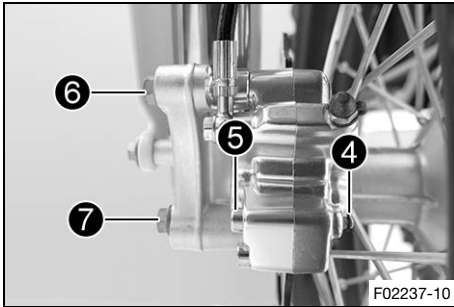

- Position the brake caliper.
- Mount and tighten screw 5.

Guideline

Screw, brake linings	M5	8 Nm (5.9 lbf ft)
----------------------	----	-------------------

- Mount lock ring 4.
- Mount screw 6, but do not tighten yet.

Guideline

Screw, front brake caliper	M8x60	20 Nm (14.8 lbf ft) <b>Loctite®243™</b>
----------------------------	-------	--

- Mount screw 7, but do not tighten yet.

Guideline

Screw, front brake caliper	M8x40	20 Nm (14.8 lbf ft) <b>Loctite®243™</b>
----------------------------	-------	--

- Operate the hand brake lever repeatedly until the brake linings are in contact with the brake disc and there is a pressure point. Secure the hand brake lever in the activated position.

✓ The brake caliper straightens.

- Tighten screw 6.

Guideline

Screw, front brake caliper	M8x60	20 Nm (14.8 lbf ft) <b>Loctite®243™</b>
----------------------------	-------	--

- Tighten screw 7.

Guideline

Screw, front brake caliper	M8x40	20 Nm (14.8 lbf ft) <b>Loctite®243™</b>
----------------------------	-------	--

- Remove the locking piece of the hand brake lever.

- Correct the brake fluid level.

Guideline

Brake fluid level under top level of container	5 mm (0.2 in)
--	---------------

Brake fluid DOT 4 / DOT 5.1 (📖 p. 137)
--

- Position cover 2 with membrane 3.
- Mount and tighten screws 1.

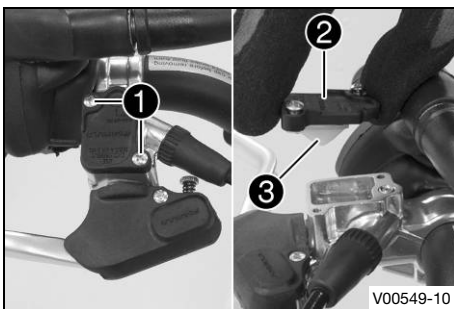

**i Info**  
Immediately clean up any brake fluid that has overflowed or spilled with water.

### Finishing work

- Remove the motorcycle from the lift stand. (📖 p. 41)

## 12.9 Checking the free travel of the foot brake lever



### Warning

**Danger of accidents** The brake system fails in the event of overheating.

If there is no free travel on the foot brake lever, pressure builds up in the brake system on the rear brake.

- Set the free travel on the foot brake lever in accordance with the specification.

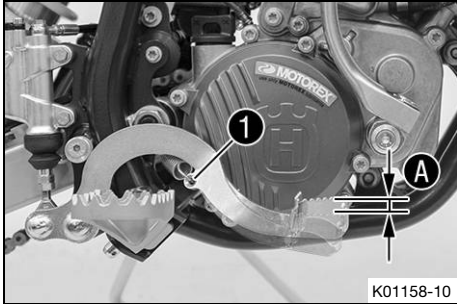

- Disconnect spring ①.
- Move the foot brake lever back and forth between the end stop and the foot brake cylinder piston bracket and check free travel A.

### Guideline

Free travel of foot brake lever	3 ... 5 mm (0.12 ... 0.2 in)
---------------------------------	------------------------------

» If the free travel does not meet specifications:

- Adjust the free travel of the foot brake lever. 📖 (p. 84)
- Attach spring ①.

## 12.10 Adjusting the free travel of the foot brake lever 📖



### Warning

**Danger of accidents** The brake system fails in the event of overheating.

If there is no free travel on the foot brake lever, pressure builds up in the brake system on the rear brake.

- Set the free travel on the foot brake lever in accordance with the specification.

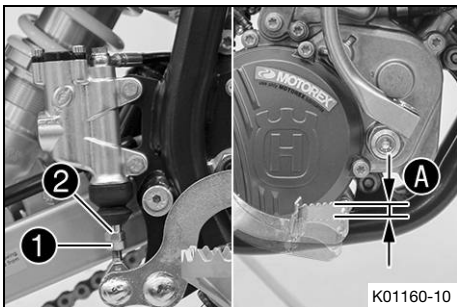

- Detach foot brake lever spring.
- Loosen nut ①.
- Turn push rod ② accordingly until you have free travel A.

### Guideline

Free travel of foot brake lever	3 ... 5 mm (0.12 ... 0.2 in)
---------------------------------	------------------------------

- Hold push rod ② and tighten nut ①.
- Attach foot brake lever spring.
- Check whether the basic position of the foot brake lever is suitable for the rider.
- » When the basic position of the foot brake lever needs to be adjusted:
  - Adjust the basic position of the foot brake lever. 📖 (p. 85)

## 12.11 Adjusting the basic position of the foot brake lever ↩



### Warning

**Danger of accidents** The brake system fails in the event of overheating.

If there is no free travel on the foot brake lever, pressure builds up in the brake system on the rear brake.

- Set the free travel on the foot brake lever in accordance with the specification.

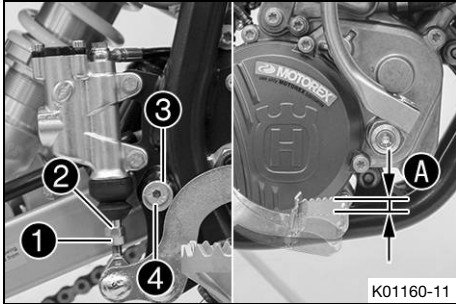

- Detach the foot brake lever spring.
- Loosen nut ①.
- Turn back push rod ② until free travel is at a maximum.
- For an individual adjustment of the basic position of the foot brake lever, loosen the screw ③ and turn the eccentric brake lever stop ④ accordingly.
- Tighten screw ③.

#### Guideline

Remaining screws, chassis	M6	10 Nm (7.4 lbf ft)
---------------------------	----	--------------------

- Turn push rod ② accordingly until you have free travel A.

#### Guideline

Free travel of foot brake lever	3 ... 5 mm (0.12 ... 0.2 in)
---------------------------------	------------------------------

- Hold push rod ② and tighten nut ①.
- Attach the foot brake lever spring.
- Check whether the basic position of the foot brake lever is suitable for the rider.



## 12.12 Checking the rear brake fluid level



### Warning

**Danger of accidents** An insufficient brake fluid level will cause the brake system to fail.

If the brake fluid level drops below the specified marking or the specified value, the brake system is leaking or the brake linings are worn down.

- Check the brake system and ensure that nobody drives the vehicle before the problem is eliminated. (Your authorized Husqvarna Motorcycles workshop will be glad to help.)



### Warning

**Danger of accidents** Old brake fluid reduces the braking effect.

- Make sure that brake fluid for the front and rear brake is changed in accordance with the service schedule. (Your authorized Husqvarna Motorcycles workshop will be glad to help.)

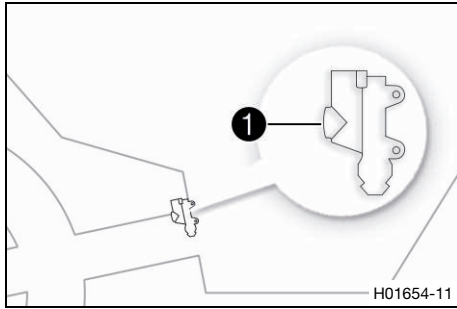

- Stand the vehicle upright.
- Check the brake fluid level in level viewer ①.
  - » If an air bubble is visible in viewer ①:
    - Add rear brake fluid. 🛠️ (📖 p. 86)

## 12.13 Adding rear brake fluid 🛠️



### Warning

**Danger of accidents** An insufficient brake fluid level will cause the brake system to fail.

If the brake fluid level drops below the specified marking or the specified value, the brake system is leaking or the brake linings are worn down.

- Check the brake system and ensure that nobody drives the vehicle before the problem is eliminated. (Your authorized Husqvarna Motorcycles workshop will be glad to help.)



### Warning

**Skin irritation** Brake fluid causes skin irritation.

- Keep brake fluid out of the reach of children.
- Wear suitable protective clothing and safety glasses.
- Do not allow brake fluid to come into contact with the skin, the eyes or clothing.
- Consult a doctor immediately if brake fluid has been swallowed.
- Rinse the affected area with plenty of water in the event of contact with the skin.
- Rinse eyes thoroughly with water immediately and consult a doctor if brake fluid comes into contact with the eyes.
- If brake fluid spills on to your clothing, change the clothing.



### Warning

**Danger of accidents** Old brake fluid reduces the braking effect.

- Make sure that brake fluid for the front and rear brake is changed in accordance with the service schedule. (Your authorized Husqvarna Motorcycles workshop will be glad to help.)



### Note

**Environmental hazard** Hazardous substances cause environmental damage.

- Dispose of oils, grease, filters, fuel, cleaning agents, brake fluid, etc., correctly and in compliance with the applicable regulations.



### Info

Never use DOT 5 brake fluid. It is silicone-based and purple in color. Oil seals and brake lines are not designed for DOT 5 brake fluid.

Avoid contact between brake fluid and painted parts. Brake fluid attacks paint.

Only use clean brake fluid from a sealed container.

### Preparatory work

- Raise the motorcycle with a lift stand. (📖 p. 41)
- Check the brake linings of the rear brake. (📖 p. 87)



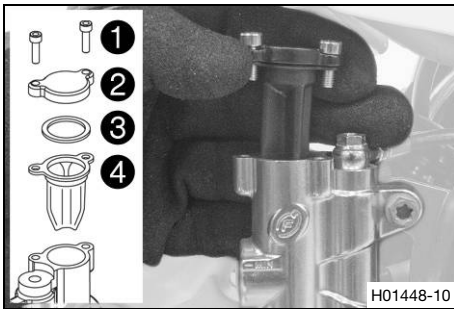

### Main work

- Remove screws ①.
- Take off cover ② with washer ③ and membrane ④.

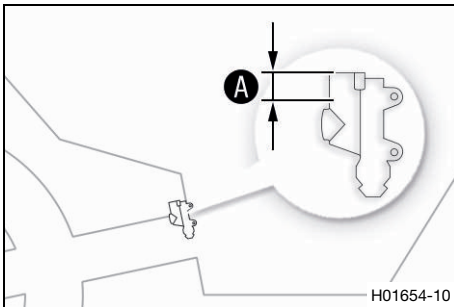

- Add brake fluid up to level A.

### Guideline

Level A (brake fluid level below reservoir rim)	10 mm (0.39 in)
---	-----------------

Brake fluid DOT 4 / DOT 5.1 (📖 p. 137)
--

- Position the cover with the washer and membrane.
- Mount and tighten the screws.

**i Info**  
Clean up overflowed or spilled brake fluid immediately with water.

### Finishing work

- Remove the motorcycle from the lift stand. (📖 p. 41)

## 12.14 Checking the brake linings of the rear brake

### Warning

**Danger of accidents** Worn-out brake linings reduce the braking effect.

- Ensure that worn-out brake linings are replaced immediately. (Your authorized Husqvarna Motorcycles workshop will be glad to help.)

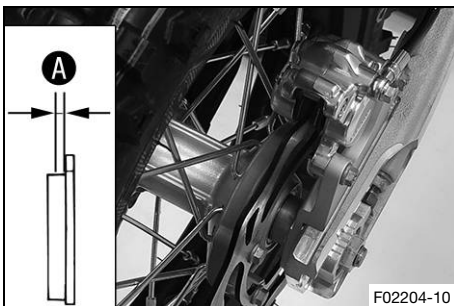

### (TC 50)

- Check the brake linings for minimum thickness A.

Minimum thickness A	≥ 1 mm (≥ 0.04 in)
---------------------	--------------------

- » If the minimum thickness is less than specified:
  - Change the brake linings of the rear brake. (📖 p. 88)
- Check the brake linings for damage and cracking.
  - » If damage or wear is encountered:
    - Change the brake linings of the rear brake. (📖 p. 88)

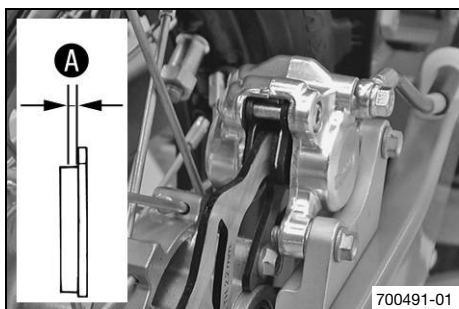

## (TC 50 MINI)

- Check the brake linings for minimum thickness **A**.

Minimum thickness <b>A</b>	$\geq 1 \text{ mm } (\geq 0.04 \text{ in})$
----------------------------	---

- » If the minimum thickness is less than specified:
  - Change the brake linings of the rear brake. (p. 88)
- Check the brake linings for damage and cracking.
  - » If damage or wear is encountered:
    - Change the brake linings of the rear brake. (p. 88)

## 12.15 Changing the brake linings of the rear brake



### Warning

**Danger of accidents** Incorrect servicing will cause the brake system to fail.

- Ensure that service work and repairs are performed professionally. (Your authorized Husqvarna Motorcycles workshop will be glad to help.)



### Warning

**Skin irritation** Brake fluid causes skin irritation.

- Keep brake fluid out of the reach of children.
- Wear suitable protective clothing and safety glasses.
- Do not allow brake fluid to come into contact with the skin, the eyes or clothing.
- Consult a doctor immediately if brake fluid has been swallowed.
- Rinse the affected area with plenty of water in the event of contact with the skin.
- Rinse eyes thoroughly with water immediately and consult a doctor if brake fluid comes into contact with the eyes.
- If brake fluid spills on to your clothing, change the clothing.



### Warning

**Danger of accidents** Old brake fluid reduces the braking effect.

- Make sure that brake fluid for the front and rear brake is changed in accordance with the service schedule. (Your authorized Husqvarna Motorcycles workshop will be glad to help.)



### Warning

**Danger of accidents** Oil or grease on the brake discs reduces the braking effect.

- Always keep the brake discs free of oil and grease.
- Clean the brake discs with brake cleaner when necessary.



### Warning

**Danger of accidents** Brake linings which have not been approved alter the braking efficiency.

Not all brake linings are tested and approved for Husqvarna motorcycles. The structure and friction coefficient of the brake linings, and thus their brake power, may vary greatly from that of original brake linings.

If brake linings are used that differ from the original equipment, compliance with the original homologation is not guaranteed. In this case, the vehicle no longer corresponds to its condition at delivery and the manufacturer warranty shall be void.

- Only use brake linings approved and recommended by Husqvarna motorcycles.

**Note**

**Environmental hazard** Hazardous substances cause environmental damage.

- Dispose of oils, grease, filters, fuel, cleaning agents, brake fluid, etc., correctly and in compliance with the applicable regulations.

**Info**

Never use DOT 5 brake fluid. It is silicone-based and purple in color. Oil seals and brake lines are not designed for DOT 5 brake fluid.

Avoid contact between brake fluid and painted parts. Brake fluid attacks paint.

Only use clean brake fluid from a sealed container.

**Preparatory work**

- Raise the motorcycle with a lift stand. (📖 p. 41)

**Main work  
(TC 50)**

- Remove lock ring ❶.
- Remove screw ❷.
- Remove screw ❸ and screw ❹.

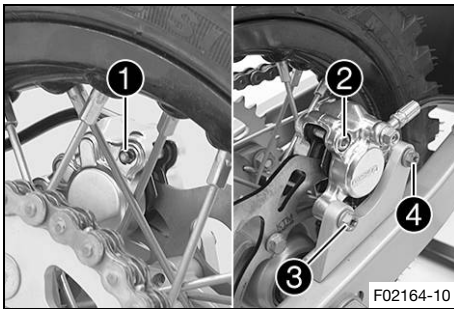

- Take off the brake caliper.

**Info**

Do not kink or damage the brake line.

- Remove the brake linings.
- Clean the brake caliper and the brake caliper bracket.
- Allow the brake caliper and the brake line to hang loosely to the side.
- Check the brake discs. (📖 p. 77)
- Remove screws ❺.
- Take off cover ❻ with washer ❼ and membrane ❽.
- Press the brake piston back into the basic position and ensure that brake fluid does not flow out of the brake fluid reservoir; extract some if necessary.

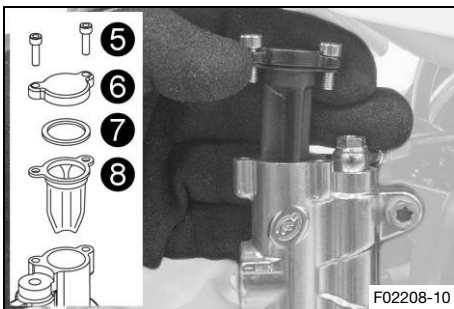

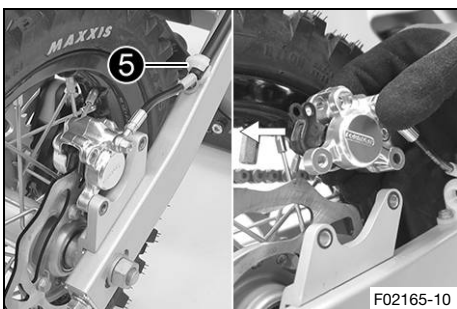
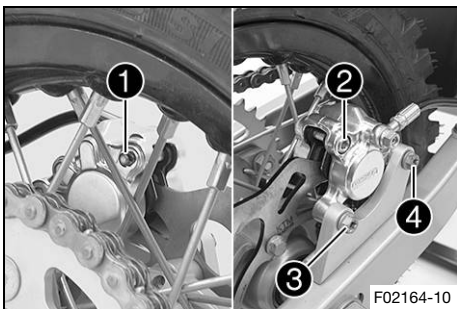
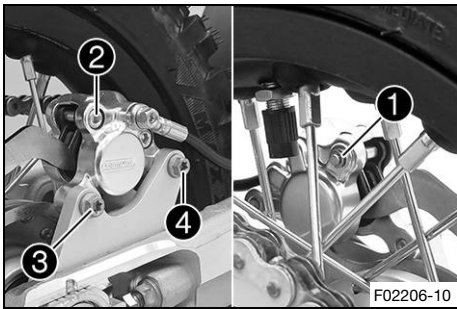
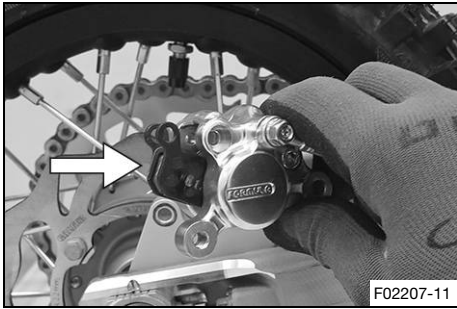

- Position the new brake linings.



### Info

Always change the brake linings in pairs. Ensure that the brake linings are correctly positioned in the holding spring.

- Position the brake caliper on the brake disc.
  - ✓ The brake linings are correctly positioned.

- Mount and tighten screw ③.

Guideline

Screw, rear brake caliper	M6x16	10 Nm (7.4 lbf ft) <b>Loctite®243™</b>
---------------------------	-------	---

- Mount and tighten screw ④.

Guideline

Screw, rear brake caliper	M6x40	10 Nm (7.4 lbf ft) <b>Loctite®243™</b>
---------------------------	-------	---

- Mount screw ②.

Guideline

Screw, brake linings	M5	8 Nm (5.9 lbf ft)
----------------------	----	-------------------

- Mount lock ring ①.

### (TC 50 MINI)

- Remove lock ring ①.
- Remove screw ②.
- Remove screw ③ and screw ④.

- Take off the brake caliper and pull the brake line out of holder ⑤.



### Info

Do not kink or damage the brake line.

- Remove the brake linings.
- Clean the brake caliper and the brake caliper bracket.
- Allow the brake caliper and the brake line to hang loosely to the side.
- Check the brake discs. (📖 p. 77)

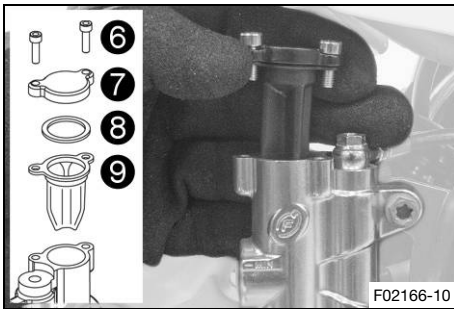

F02166-10

- Remove screws ⑥.
- Take off cover ⑦ with washer ⑧ and membrane ⑨.
- Press the brake piston back into the basic position and ensure that brake fluid does not flow out of the brake fluid reservoir; extract some if necessary.

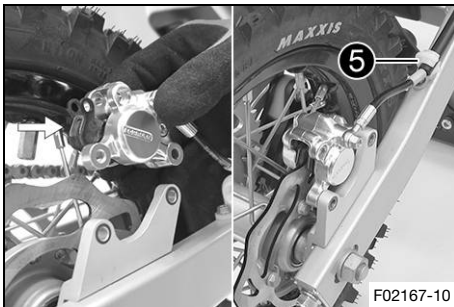

F02167-10

- Position the new brake linings.



### Info

Always change the brake linings in pairs. Ensure that the brake linings are correctly positioned in the holding spring.

- Position the brake caliper on the brake disc.  
✓ The brake linings are correctly positioned.

- Attach the brake line to holder ⑤.

- Mount and tighten screw ③.

#### Guideline

Screw, rear brake caliper	M6x16	10 Nm (7.4 lbf ft) <b>Loctite®243™</b>
---------------------------	-------	---

- Mount and tighten screw ④.

#### Guideline

Screw, rear brake caliper	M6x40	10 Nm (7.4 lbf ft) <b>Loctite®243™</b>
---------------------------	-------	---

- Mount screw ②.

#### Guideline

Screw, brake linings	M5	8 Nm (5.9 lbf ft)
----------------------	----	-------------------

- Mount lock ring ①.

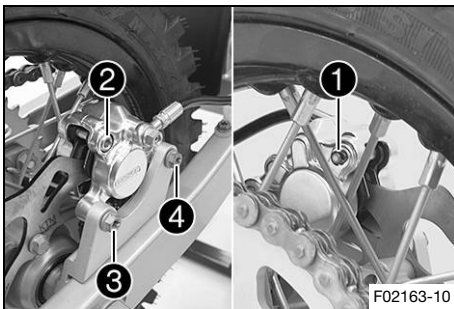

F02163-10

- Operate the foot brake lever repeatedly until the brake linings are in contact with the brake disc and there is a pressure point.

- Add brake fluid up to level A.

#### Guideline

Level A (brake fluid level below reservoir rim)	10 mm (0.39 in)
---	-----------------

Brake fluid DOT 4 / DOT 5.1 (📖 p. 137)

- Position cover with washer and membrane.
- Mount and tighten the screws.

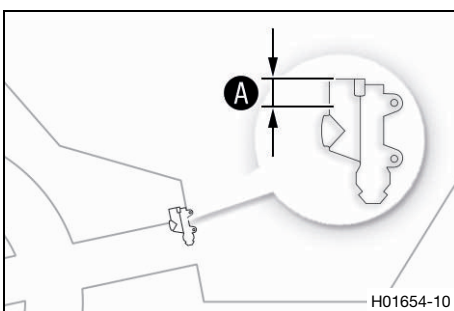

H01654-10



### Info

Immediately clean up any brake fluid that has overflowed or spilled with water.

### Finishing work

- Remove the motorcycle from the lift stand. (📖 p. 41)



## 13.1 Removing the front wheel ↴

### Preparatory work

- Raise the motorcycle with a lift stand. (📖 p. 41)

### Main work

- Remove screw ❶.
- Loosen screws ❷.

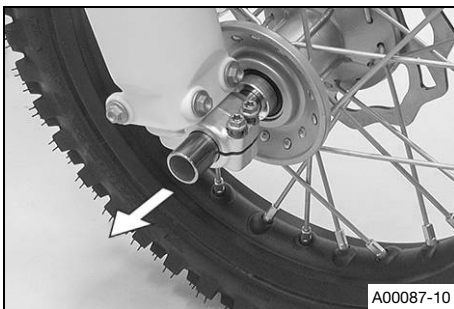
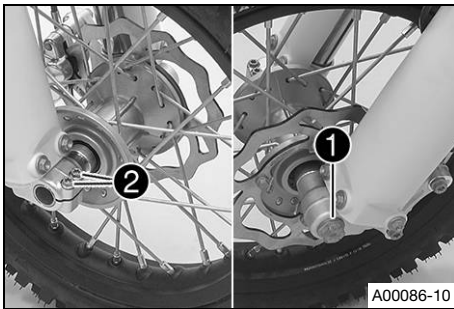

### Warning

**Danger of accidents** Damaged brake discs reduce the braking effect.

- Always lay the wheel down in such a way that the brake disc is not damaged.

- Hold the front wheel and remove the wheel spindle. Take the front wheel out of the fork.



### Info

Do not actuate the hand brake lever when the front wheel is removed.

- Remove spacers ❸.

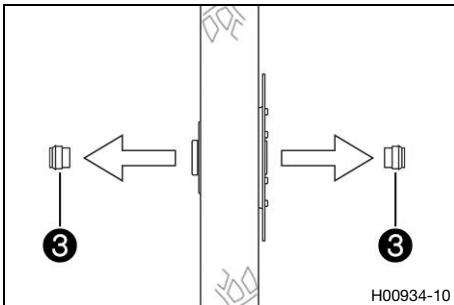

## 13.2 Installing the front wheel ↴



### Warning

**Danger of accidents** Oil or grease on the brake discs reduces the braking effect.

- Always keep the brake discs free of oil and grease.
- Clean the brake discs with brake cleaner when necessary.

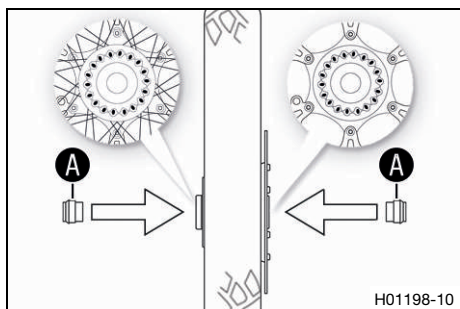

- Check the wheel bearing for damage and wear.
  - » If the wheel bearing is damaged or worn:
    - Change front wheel bearing. 🛠️
- Clean and grease the contact surfaces **A** of the spacers.

Long-life grease (📖 p. 139)

- Insert the spacers.

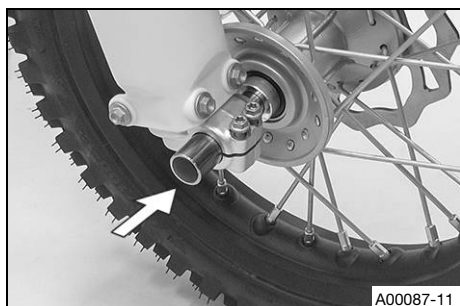

- Clean and grease the wheel spindle.

Long-life grease (📖 p. 139)

- Position the front wheel.
  - ✓ The brake linings are correctly positioned.
- Insert the wheel spindle.

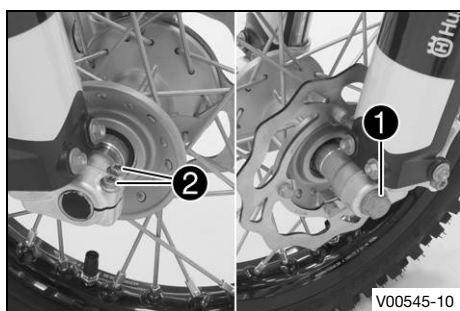

- Mount and tighten screw **1**.

Guideline

Screw, front wheel spindle	M10	40 Nm (29.5 lbf ft) <b>Loctite® 243™</b>
----------------------------	-----	---

- Operate the hand brake lever several times until the brake linings are seated correctly against the brake disc.
- Remove the motorcycle from the lift stand. (📖 p. 41)
- Operate the front brake and compress the fork a few times firmly.
  - ✓ The fork legs straighten.

- Tighten screws **2**.

Guideline

Screw, fork stub	M6	10 Nm (7.4 lbf ft)
------------------	----	--------------------

## 13.3 Removing the rear wheel 🛠️

### Preparatory work

- Raise the motorcycle with a lift stand. (📖 p. 41)

### Main work (TC 50)

- Remove nut **1**.
- Take off chain adjuster **2**.

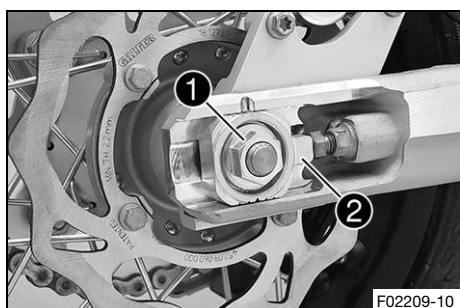



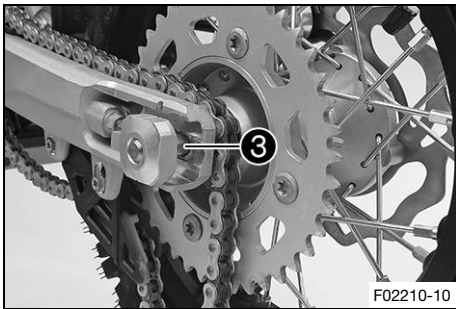

F02210-10

- Pull out wheel spindle ③ far enough to allow the rear wheel to be pushed forward.
- Push the rear wheel forward as far as possible. Remove the chain from the rear sprocket.



**Info**

Cover the components to protect them against damage.



**Warning**

**Danger of accidents** Damaged brake discs reduce the braking effect.

- Always lay the wheel down in such a way that the brake disc is not damaged.

- Hold the rear wheel and remove the wheel spindle. Take the rear wheel out of the link fork.



**Info**

Do not operate the foot brake lever when the rear wheel is removed.

- Remove spacers ④.

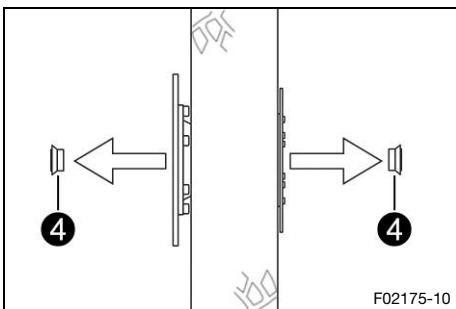

F02175-10

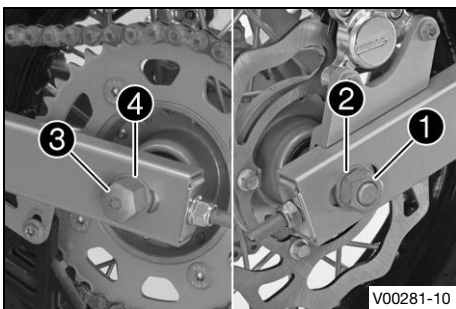

V00281-10

**(TC 50 MINI)**

- Remove nut ① with washer ②.



**Info**

Cover the components to protect them against damage.

- Pull out wheel spindle ③ with washer ④.
- Remove the chain from the rear sprocket.



**Warning**

**Danger of accidents** Damaged brake discs reduce the braking effect.

- Always lay the wheel down in such a way that the brake disc is not damaged.

- Take the rear wheel out of the link fork.

**i Info**  
Do not operate the foot brake lever when the rear wheel is removed.

- Remove spacers **5**.

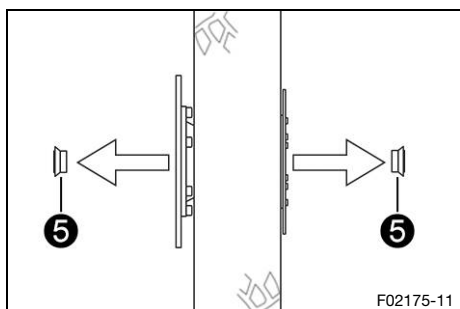

## 13.4 Installing the rear wheel

**! Warning**  
**Danger of accidents** Oil or grease on the brake discs reduces the braking effect.

- Always keep the brake discs free of oil and grease.
- Clean the brake discs with brake cleaner when necessary.

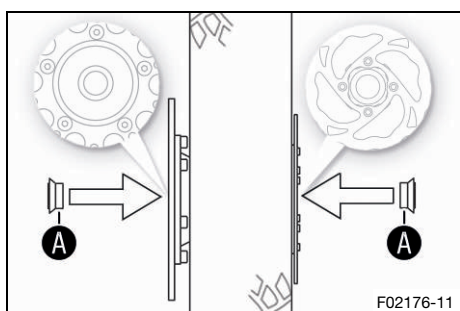

### Main work

- Check the wheel bearing for damage and wear.
  - » If the wheel bearing is damaged or worn:
    - Change the rear wheel bearing.
- Clean and grease the contact surfaces **A** of the spacers.

Long-life grease (p. 139)

- Insert the spacers.

**i Info**  
Insert the wide spacer on the left in the direction of travel.

### (TC 50)

- Clean and grease wheel spindle **1**.

Long-life grease (p. 139)

- Position the rear wheel and insert wheel spindle.
  - ✓ The brake linings are correctly positioned.
- Mount the chain.
- Position chain adjuster **2** on both sides and push the wheel spindle in all the way.

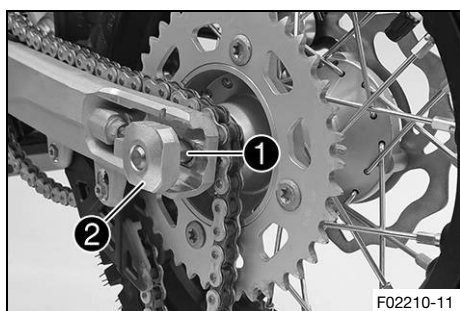

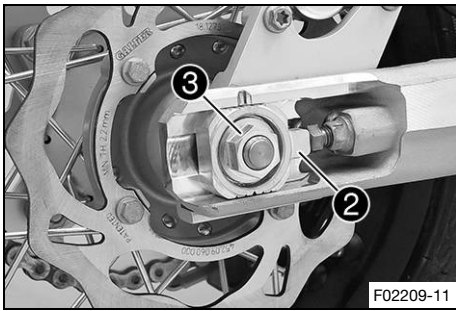

- Mount nut **3**, but do not tighten it yet.
- Make sure that the chain adjusters are fitted correctly on the adjusting screws.
- Check the chain tension. (📖 p. 67)
- Tighten nut **3**.

Guideline

Nut, rear wheel spindle	M12x1	40 Nm (29.5 lbf ft)
-------------------------	-------	---------------------

- Operate the foot brake lever repeatedly until the brake linings are in contact with the brake disc and there is a pressure point.

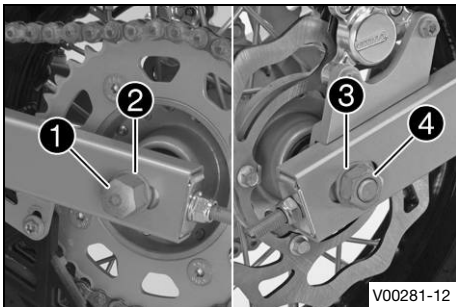

**(TC 50 MINI)**

- Clean and grease wheel spindle **1**.

Long-life grease (📖 p. 139)
-----------------------------

- Position rear wheel and mount the chain.  
✓ The brake linings are correctly positioned.
- Insert wheel spindle **1** with washer **2**.
- Position washer **3**. Mount nut **4**, but do not tighten it yet.
- Make sure that the chain adjuster support plates are in contact with the adjusting nuts.
- Check the chain tension. (📖 p. 67)
- Tighten nut **4**.

Guideline

Nut, rear wheel spindle	M12x1	40 Nm (29.5 lbf ft)
-------------------------	-------	---------------------

- Operate the foot brake lever repeatedly until the brake linings are in contact with the brake disc and there is a pressure point.

**Finishing work**

- Remove the motorcycle from the lift stand. (📖 p. 41)

## 13.5 Checking the tire condition

**i Info**

Only mount tires approved and/or recommended by Husqvarna Motorcycles.

Other tires could have a negative effect on handling characteristics.

The type, condition, and pressure of the tires all have a major impact on the handling characteristic of the motorcycle.

The tires mounted on the front and rear wheels must have a similar profile.

Worn tires have a negative effect on handling characteristics, especially on wet surfaces.

# 13 WHEELS, TIRES

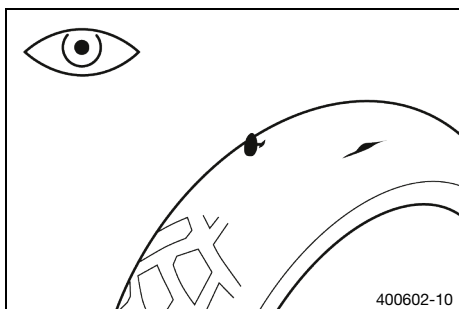

- Check the front and rear tires for cuts, embedded objects, and other damage.
  - » If the tires have cuts, run-in objects, or other damage:
    - Change the tires. 🛠️
- Check the tread depth.

**i Info**  
Observe the minimum profile depth required by national law.

Minimum tread depth	≥ 2 mm (≥ 0.08 in)
---------------------	--------------------

- » If the tread depth is less than the minimum tread depth:
  - Change the tires. 🛠️

- Check the tire age.

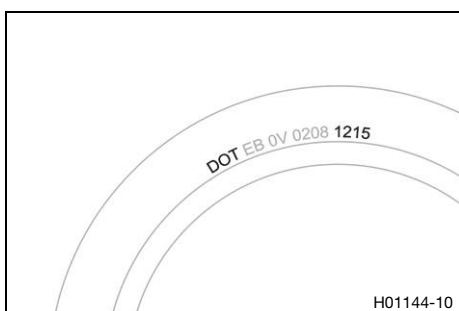

**i Info**  
The tire date of manufacture is usually contained in the tire label and is indicated by the last four digits of the **DOT** number. The first two digits indicate the week of manufacture and the last two digits the year of manufacture.  
Husqvarna Motorcycles recommends that the tires be changed after 5 years at the latest, regardless of the actual wear.

- » If the tires are more than 5 years old:
  - Change the tires. 🛠️

## 13.6 Checking tire pressure

**i Info**  
Low tire pressure leads to abnormal wear and overheating of the tire.  
Correct tire pressure ensures optimal riding comfort and maximum tire service life.

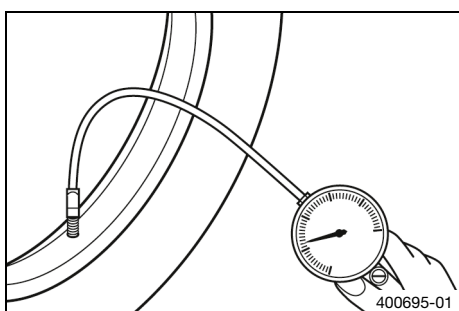

- Remove protection cap.
- Check tire pressure when the tires are cold.

Offroad tire pressure	
front	1.0 bar (15 psi)
rear	1.0 bar (15 psi)

- » If the tire pressure does not meet specifications:
  - Correct tire pressure.
- Mount the protection cap.

## 13.7 Checking spoke tension



### Warning

**Danger of accidents** Incorrectly tensioned spokes impair the handling characteristic and result in secondary damage.

The spokes break due to being overloaded if they are too tightly tensioned. If the tension in the spokes is too low, then lateral and radial run-out will form in the wheel. Other spokes will become looser as a result.

- Check spoke tension regularly, and in particular on a new vehicle. (Your authorized Husqvarna Motorcycles workshop will be glad to help.)

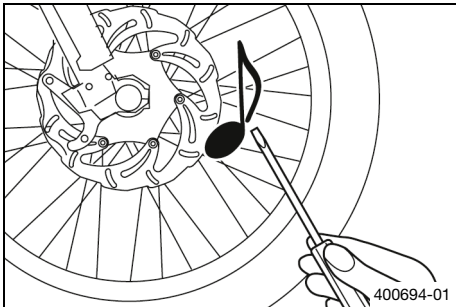

- Strike each spoke briefly using a screwdriver blade.



### Info

The frequency of the sound depends on the spoke length and spoke diameter. If you hear different tone frequencies from different spokes of equal length and diameter, this is an indication of different spoke tensions.

You should hear a high note.

- » If the spoke tension differs:
  - Correct the spoke tension. ↩
- Check the spoke torque.

### Guideline

Spoke nipple	M3.5	3 Nm (2.2 lbf ft)
--------------	------	-------------------

Torque wrench kit (58429094000)

## 14.1 Cooling system

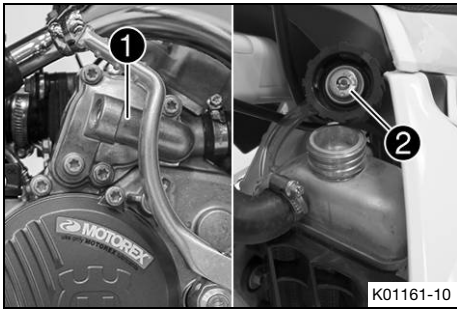

The water pump ① in the engine forces the coolant to flow. The pressure resulting from the warming of the cooling system is regulated by a valve in the radiator cap ②. This ensures that operating the vehicle at the specified coolant temperature will not result in a risk of malfunctions.

120 °C (248 °F)
-----------------

Cooling is effected by the air stream. The lower the speed, the less the cooling effect. Dirty cooling fins also reduce the cooling effect.

## 14.2 Checking the antifreeze and coolant level

### Warning

**Danger of scalding** During motorcycle operation, the coolant gets very hot and is under pressure.

- Do not open the radiator, the radiator hoses or other cooling system components if the engine or the cooling system are at operating temperature.
- Allow the cooling system and the engine to cool down before you open the radiator, the radiator hoses or other components of the cooling system.
- In the event of scalding, rinse the area affected immediately with lukewarm water.

### Warning

**Danger of poisoning** Coolant is toxic and a health hazard.

- Keep coolant out of the reach of children.
- Do not allow coolant to come into contact with the skin, the eyes and clothing.
- Consult a doctor immediately if coolant is swallowed.
- Rinse the affected area immediately with plenty of water in the event of contact with the skin.
- Rinse eyes thoroughly with water and consult a doctor immediately if coolant gets into the eyes.
- Change clothing if coolant spills onto your clothing.

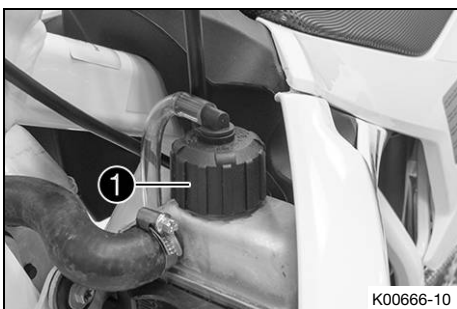

- Stand the motorcycle upright on a horizontal surface.
- Take off radiator cap ①.
- Check the antifreeze in the coolant.

-25 ... -45 °C (-13 ... -49 °F)
---------------------------------

- » If the antifreeze in the coolant does not match the specified value:
  - Correct the antifreeze in the coolant.

- Check the coolant level in the radiator.

Coolant level ① above the radiator fins	10 mm (0.39 in)
---	-----------------

- » If the coolant level does not match the specified value:
  - Correct the coolant level.

Coolant (📖 p. 137)
--------------------

- Mount the radiator cap.

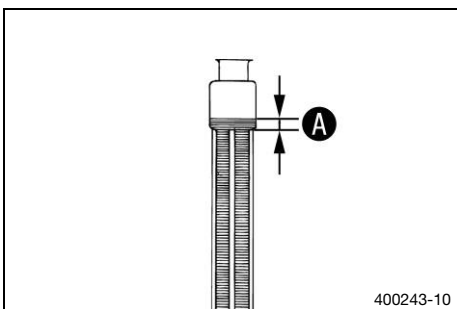

## 14.3 Checking the coolant level



### Warning

**Danger of scalding** During motorcycle operation, the coolant gets very hot and is under pressure.

- Do not open the radiator, the radiator hoses or other cooling system components if the engine or the cooling system are at operating temperature.
- Allow the cooling system and the engine to cool down before you open the radiator, the radiator hoses or other components of the cooling system.
- In the event of scalding, rinse the area affected immediately with lukewarm water.



### Warning

**Danger of poisoning** Coolant is toxic and a health hazard.

- Keep coolant out of the reach of children.
- Do not allow coolant to come into contact with the skin, the eyes and clothing.
- Consult a doctor immediately if coolant is swallowed.
- Rinse the affected area immediately with plenty of water in the event of contact with the skin.
- Rinse eyes thoroughly with water and consult a doctor immediately if coolant gets into the eyes.
- Change clothing if coolant spills onto your clothing.

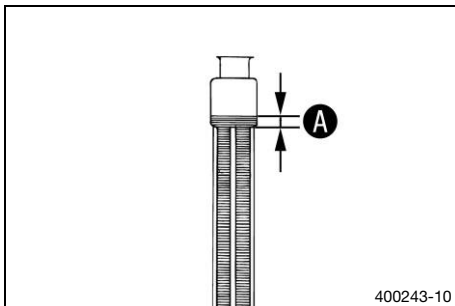

- Stand the motorcycle upright on a horizontal surface.
- Remove the radiator cap.
- Check the coolant level in the radiator.

Coolant level <b>A</b> above the radiator fins	10 mm (0.39 in)
--	-----------------

» If the coolant level does not match the specified value:

- Correct the coolant level.

Coolant (📖 p. 137)
--------------------

- Mount the radiator cap.



## 14.4 Draining the coolant ↴



### Warning

**Danger of scalding** During motorcycle operation, the coolant gets very hot and is under pressure.

- Do not open the radiator, the radiator hoses or other cooling system components if the engine or the cooling system are at operating temperature.
- Allow the cooling system and the engine to cool down before you open the radiator, the radiator hoses or other components of the cooling system.
- In the event of scalding, rinse the area affected immediately with lukewarm water.



## Warning

**Danger of poisoning** Coolant is toxic and a health hazard.

- Keep coolant out of the reach of children.
- Do not allow coolant to come into contact with the skin, the eyes and clothing.
- Consult a doctor immediately if coolant is swallowed.
- Rinse the affected area immediately with plenty of water in the event of contact with the skin.
- Rinse eyes thoroughly with water and consult a doctor immediately if coolant gets into the eyes.
- Change clothing if coolant spills onto your clothing.

## Condition

The engine is cold.

- Position the motorcycle upright.
- Place an appropriate container under the water pump cover.
- Remove screw ❶. Take off the radiator cap.
- Completely drain the coolant.
- Mount and tighten screw ❶ with a new seal ring.

## Guideline

Drain plug, water pump cover	M6	6 Nm (4.4 lbf ft)
------------------------------	----	-------------------



## 14.5 Refilling with coolant ↩



## Warning

**Danger of poisoning** Coolant is toxic and a health hazard.

- Keep coolant out of the reach of children.
- Do not allow coolant to come into contact with the skin, the eyes and clothing.
- Consult a doctor immediately if coolant is swallowed.
- Rinse the affected area immediately with plenty of water in the event of contact with the skin.
- Rinse eyes thoroughly with water and consult a doctor immediately if coolant gets into the eyes.
- Change clothing if coolant spills onto your clothing.

## Main work

- Make sure that screw ❶ is tightened.
- Position the motorcycle upright.
- Add coolant to level A.

## Guideline

Distance A above the radiator fins	10 mm (0.39 in)
------------------------------------	-----------------

Coolant	0.7 l (0.7 qt.)	Coolant (📖 p. 137)
---------	-----------------	--------------------

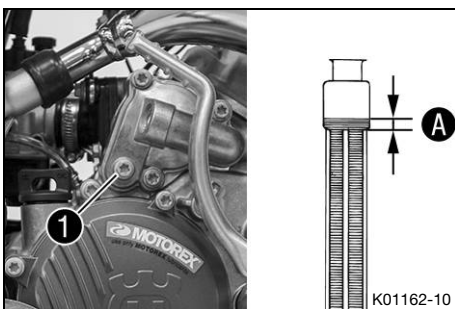



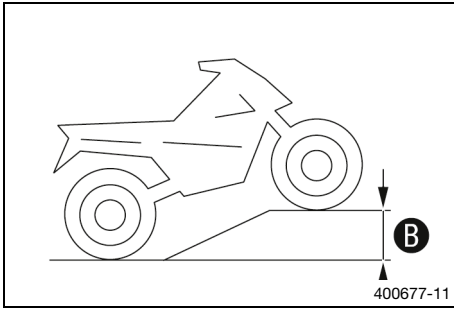

- Move the vehicle into the position shown and prevent it from rolling away. Height difference **B** must be reached.

Guideline

Height difference <b>B</b>	50 cm (19.7 in)
----------------------------	-----------------

**i Info**  
For all of the air to be able to escape from the cooling system, the vehicle must be raised at the front. If the cooling system is poorly de-aerated, its cooling power will be reduced and the engine may overheat.

- Return the vehicle to the horizontal position.
- Add coolant to level **A**.
- Mount the radiator cap.

#### Finishing work

- Go for a short test ride.
- Check the cooling system for leaks.
- Check the coolant level. (📖 p. 101)



## 14.6 Changing the coolant ↴



### Warning

**Danger of scalding** During motorcycle operation, the coolant gets very hot and is under pressure.

- Do not open the radiator, the radiator hoses or other cooling system components if the engine or the cooling system are at operating temperature.
- Allow the cooling system and the engine to cool down before you open the radiator, the radiator hoses or other components of the cooling system.
- In the event of scalding, rinse the area affected immediately with lukewarm water.



### Warning

**Danger of poisoning** Coolant is toxic and a health hazard.

- Keep coolant out of the reach of children.
- Do not allow coolant to come into contact with the skin, the eyes and clothing.
- Consult a doctor immediately if coolant is swallowed.
- Rinse the affected area immediately with plenty of water in the event of contact with the skin.
- Rinse eyes thoroughly with water and consult a doctor immediately if coolant gets into the eyes.
- Change clothing if coolant spills onto your clothing.

#### Condition

The engine is cold.

- Position the motorcycle upright.
- Place an appropriate container under the water pump cover.

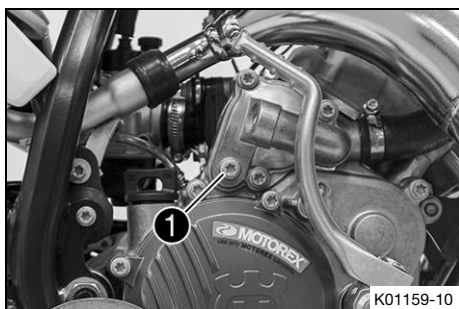

- Remove screw ①. Take off the radiator cap.
- Completely drain the coolant.
- Mount and tighten screw ① with a new seal ring.

Guideline

Drain plug, water pump cover	M6	6 Nm (4.4 lbf ft)
------------------------------	----	-------------------

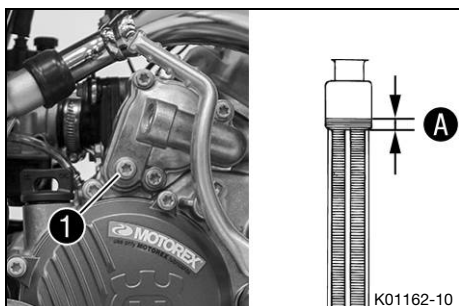

- Make sure that screw ① is tightened.
- Add coolant to level ①.

Guideline

Distance ① above the radiator fins	10 mm (0.39 in)
------------------------------------	-----------------

Coolant	0.7 l (0.7 qt.)	Coolant (📖 p. 137)
---------	-----------------	--------------------

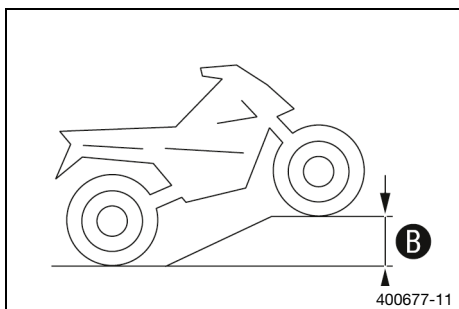

- Move the vehicle into the position shown and secure it against rolling away. Height difference ① must be reached.

Guideline

Height difference ①	50 cm (19.7 in)
---------------------	-----------------

### **i** Info

For all of the air to be able to escape from the cooling system, the vehicle must be raised at the front. If the cooling system is poorly de-aerated, its cooling power will be reduced and the engine may overheat.

- Return the vehicle to the horizontal position.
- Add coolant to level ①.
- Mount the radiator cap.

### Finishing work

- Go for a short test ride.
- Check the cooling system for leaks.
- Check the coolant level. (📖 p. 101)

## 15.1 Checking the throttle cable play

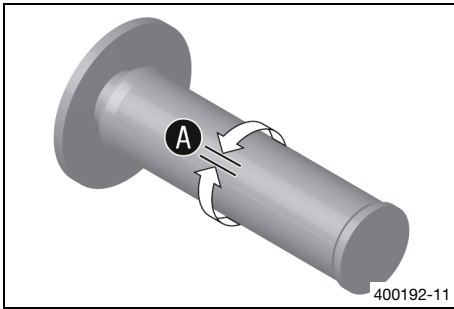

- Check the throttle grip for smooth operation.
- Move the handlebar to the straight-ahead position. Turn the throttle grip back and forth slightly and determine the play in throttle cable **A**.

Throttle cable play	3 ... 5 mm (0.12 ... 0.2 in)
---------------------	------------------------------

- » If the throttle cable play does not meet specifications:
  - Adjust the throttle cable play. 🛠️ (📖 p. 105)



### Danger

**Danger of poisoning** Exhaust gases are toxic and inhaling them may result in unconsciousness and death.

- Always make sure there is sufficient ventilation when running the engine.
- Use effective exhaust extraction when starting or running the engine in an enclosed space.

- Start the engine and let it run at idle speed. Move the handlebar to and fro over the entire steering range.

The idle speed must not change.
---------------------------------

- » If the idle speed changes:
  - Adjust the throttle cable play. 🛠️ (📖 p. 105)



## 15.2 Adjusting the throttle cable play 🛠️

### Preparatory work

- Remove the seat. (📖 p. 61)
- Remove the left side cover. (📖 p. 57)
- Remove the right side cover. (📖 p. 55)
- Turn the knurled screw on the fuel tap all the way clockwise.
- Remove the fuel tank. 🛠️ (📖 p. 52)
- Check the throttle cable routing. (📖 p. 74)

### Main work

- Move the handlebar to the straight-ahead position.
- Push back sleeve **1**.
- Ensure that the throttle cable sleeve is pushed all the way into barrel adjuster **2**.
- Loosen nut **3**.

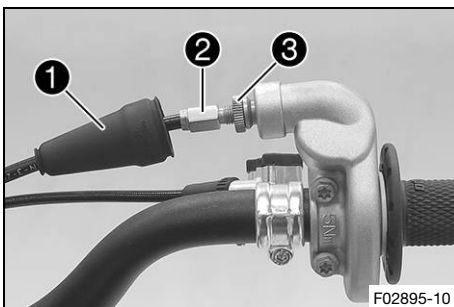

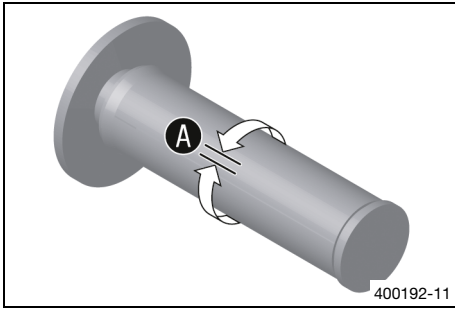

- Turn barrel adjuster **2** so that there is play **A** in the throttle cable at the throttle grip.

Guideline

Throttle cable play	3 ... 5 mm (0.12 ... 0.2 in)
---------------------	------------------------------

- Tighten nut **3**.
- Slide on sleeve **1**.

### Finishing work

- Install the fuel tank. (📖 p. 53)
- Install the left side cover. (📖 p. 58)
- Install the right side cover. (📖 p. 56)
- Mount the seat. (📖 p. 61)
- Check the throttle cable play. (📖 p. 105)

## 15.3 Carburetor – idle setting (TC 50)

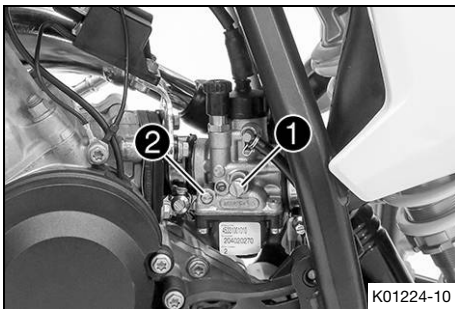

The idle setting of the carburetor has a big influence on the starting behavior, stable idle speed, and the response to throttle opening. This means that an engine with a correctly set idle speed will be easier to start than one with an incorrectly set idle speed.

### **i** Info

The carburetor and its components are subject to increased wear caused by engine vibration. Wear can result in malfunctioning.

The idle speed is adjusted using the idle speed adjusting screw **1**.

The idle mixture is adjusted using the idle air adjusting screw **2**.

## 15.4 Carburetor – idle setting (TC 50 MINI)

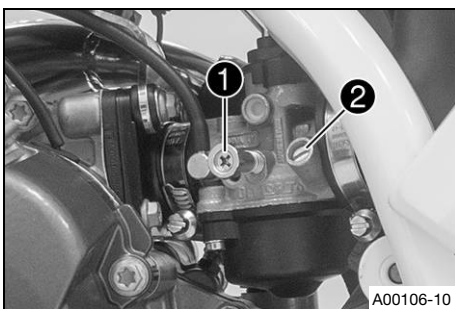

The idle setting of the carburetor has a big influence on the starting behavior, stable idle speed, and the response to throttle opening. This means that an engine with a correctly set idle speed will be easier to start than one with an incorrectly set idle speed.

### **i** Info

The carburetor and its components are subject to increased wear caused by engine vibration. Wear can result in malfunctioning.

The idle speed is adjusted using the idle speed adjusting screw **1**.

The idle mixture is adjusted using the idle air adjusting screw **2**.

## 15.5 Carburetor - adjusting the idle speed ↙ (TC 50)

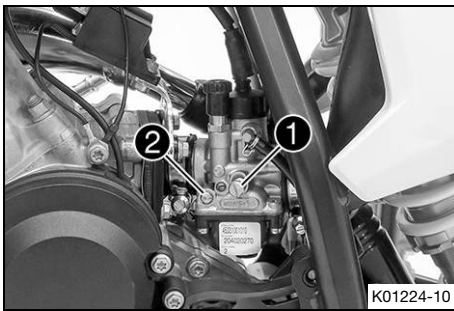

- Screw in idle air adjusting screw ② all the way and turn it to the specified basic setting.

Guideline

Idle air adjusting screw	
Open	3 turns

- Run the engine until warm.

Guideline

Warming-up phase	≥ 5 min
------------------	---------

- Connect the special tool.

Tachometer (45129075000)
--------------------------



### Danger

**Danger of poisoning** Exhaust gases are toxic and inhaling them may result in unconsciousness and death.

- Always make sure there is sufficient ventilation when running the engine.
- Use effective exhaust extraction when starting or running the engine in an enclosed space.

- Adjust the idle speed using idle speed adjusting screw ①.

Guideline

Choke function deactivated – The choke lever is pushed in to the stop. (📖 p. 17)	
Idle speed	1,400 ... 1,500 rpm

- Turn idle air adjusting screw ② slowly in a clockwise direction until the idle speed begins to fall.
- Note the position and turn the idle air adjusting screw slowly counterclockwise until the idle speed again begins to fall.
- Adjust to the point between these two positions with the highest idle speed.



### Info

If there is a big engine speed rise, reduce the idle speed to a normal level and repeat the above steps. If the procedure described here does not lead to satisfactory results, the cause may be a wrongly dimensioned idling jet. If you can turn the idle air adjusting screw to the end without any change of engine speed, mount a smaller idling jet. After changing the idling jet, start from the beginning with the adjusting steps. Following extreme air temperature or altitude changes, adjust the idle speed again.

## 15.6 Carburetor – adjusting the idle speed ↻ (TC 50 MINI)

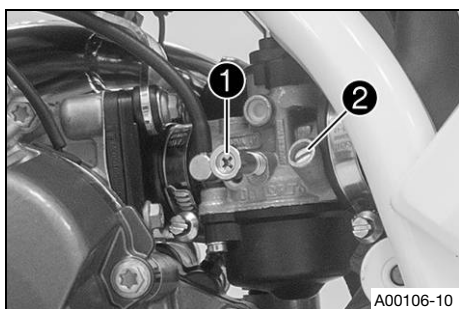

- Screw in idle air adjusting screw ② all the way and turn it to the specified basic setting.

Guideline

Idle air adjusting screw	
Open	1 turn

- Run the engine until warm.

Guideline

Warming-up phase	≥ 5 min
------------------	---------

- Connect the special tool.

Tachometer (45129075000)
--------------------------



### Danger

**Danger of poisoning** Exhaust gases are toxic and inhaling them may result in unconsciousness and death.

- Always make sure there is sufficient ventilation when running the engine.
- Use effective exhaust extraction when starting or running the engine in an enclosed space.

- Adjust the idle speed using idle speed adjusting screw ①.

Guideline

Choke function deactivated – The choke lever is pushed down all the way to the stop. (📖 p. 18)	
Idle speed	1,400 ... 1,500 rpm

- Turn idle air adjusting screw ② slowly in a clockwise direction until the idle speed begins to fall.
- Note the position and turn the idle air adjusting screw slowly counterclockwise until the idle speed again begins to fall.
- Adjust to the point between these two positions with the highest idle speed.



### Info

If there is a big engine speed rise, reduce the idle speed to a normal level and repeat the above steps. If the procedure described here does not lead to satisfactory results, the cause may be a wrongly dimensioned idling jet. If you can turn the idle air adjusting screw to the end without any change of engine speed, mount a smaller idling jet. After changing the idling jet, start from the beginning with the adjusting steps. Following extreme air temperature or altitude changes, adjust the idle speed again.

## 15.7 Checking the clutch setting

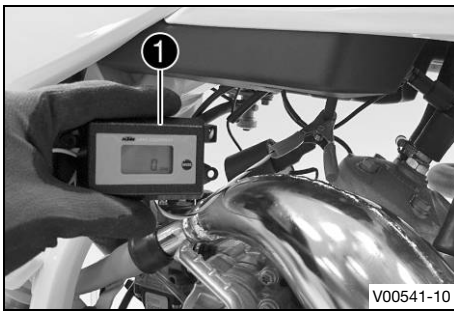

V00541-10

- Connect special tool ①.

Tachometer (45129075000)
--------------------------

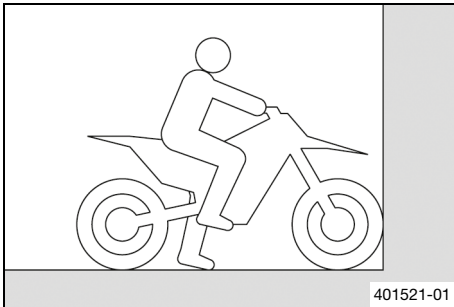

401521-01

- Let the front wheel of the vehicle make contact with a fixed object.



### Danger

**Danger of poisoning** Exhaust gases are toxic and inhaling them may result in unconsciousness and death.

- Always make sure there is sufficient ventilation when running the engine.
- Use effective exhaust extraction when starting or running the engine in an enclosed space.

- Start the motorcycle.
- Only ride full throttle to the point where the maximum engine speed is reached.

#### Guideline

Operation at full throttle	≤ 3 s
----------------------------	-------

- Read the speed.

Slip speed	8,700 ... 9,300 rpm
------------	---------------------

- » If the specified value is not reached:
  - Adjust the clutch.  (📖 p. 110)



## 15.8 Removing the clutch cover



### Note

**Environmental hazard** Improper handling of fuel is a danger to the environment.

- Do not allow fuel to enter the groundwater, the soil, or the sewage system.



### Info

Fuel can emerge via the carburetor.  
Capture emerging fuel using a suitable container.

- Turn the knurled screw on the fuel tap all the way clockwise.

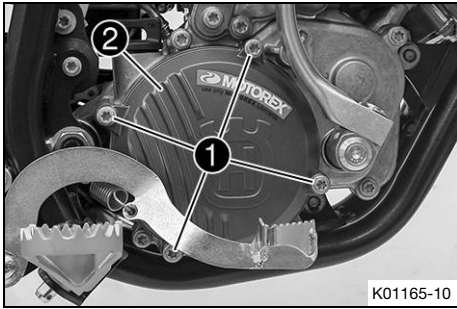

K01165-10

- Lay the vehicle down on its left side.
- Remove screws **1**.
- Remove clutch cover **2** with the seal ring.

## 15.9 Adjusting the clutch ↘

### Preparatory work

- Remove the clutch cover. ↘ (p. 109)

### Main work

- Turn the outer clutch hub **1** until adjusting screws **2** become accessible.

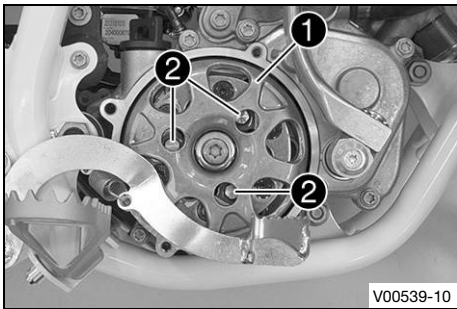

V00539-10

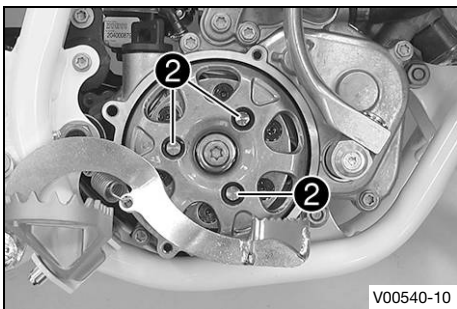

V00540-10

### Condition

If there is no reference point:

- Turn adjusting screws **2** counterclockwise to the last detectable click.
- Turn adjusting screws **2** clockwise by 9 clicks to the basic setting.

#### Guideline

Basic setting of slip speed	8,700 ... 9,300 rpm
-----------------------------	---------------------



### Info

The springs may not be pretensioned by more than 17 clicks from the stop using the adjusting screws.

### Condition

If the slip speed is too low:

- Turn adjusting screws **2** clockwise.

#### Guideline

1 click increases the slip speed by	250 ... 350 rpm
-------------------------------------	-----------------



### Info

The springs may not be pretensioned by more than 17 clicks from the stop using the adjusting screws.

### Condition

If the slip speed is too high:



- Turn adjusting screws ② counterclockwise.

Guideline

1 click decreases the slip speed by	250 ... 350 rpm
-------------------------------------	-----------------

### Finishing work

- Install the clutch cover. (🔧 p. 111)
- Check the gear oil level. (📖 p. 113)
- Check the clutch setting. (🔧 p. 109)



## 15.10 Installing the clutch cover 🔧

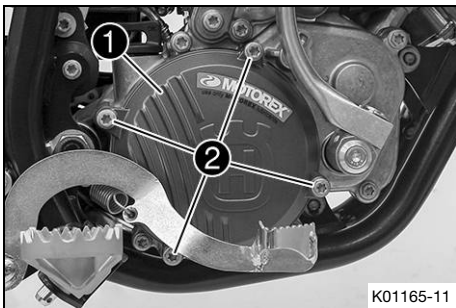

### Main work

- Position the clutch cover ① with the seal ring.
- Mount and tighten screws ②.

Guideline

Screw, clutch cover	M6	10 Nm (7.4 lbf ft)
---------------------	----	--------------------

### Finishing work

- Check the gear oil level. (📖 p. 113)



## 16.1 Checking oil level (TC 50 MINI)

### Preparatory work

- Stand the motorcycle upright on a horizontal surface.

### Main work

- Check the oil level in the oil tank.

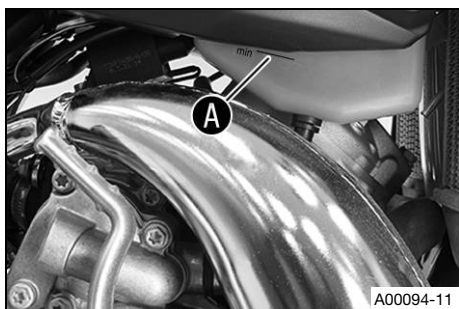

For a full fuel tank, the oil tank must be filled up to **MIN** mark **A** at a minimum.

- » If the oil level does not meet specifications:
  - Fill up with oil. (📖 p. 26)

## 16.2 Bleeding the oil pump ↘ (TC 50 MINI)

### Condition

The fuel tank has been removed.

- Pull off oil line **1**.

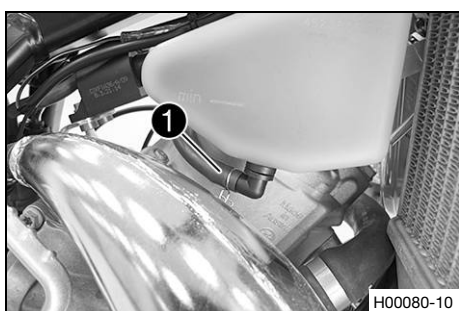

- Fill the oil line with a syringe.

Engine oil, 2-stroke (📖 p. 137)

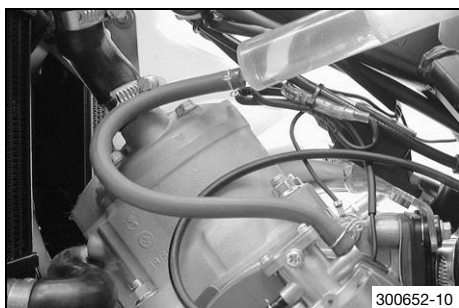

- Connect oil line **1**.

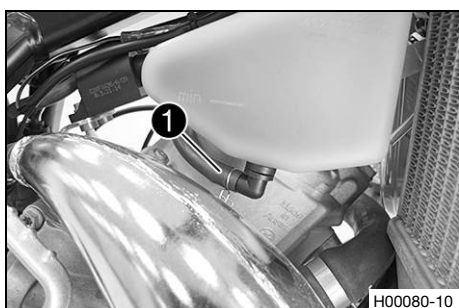

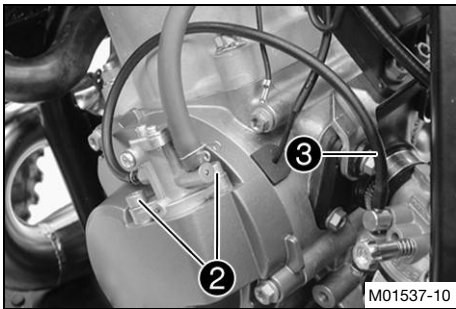

- Remove screws ②.
- Take off the oil pump.
- Pull off oil line ③ from the carburetor.

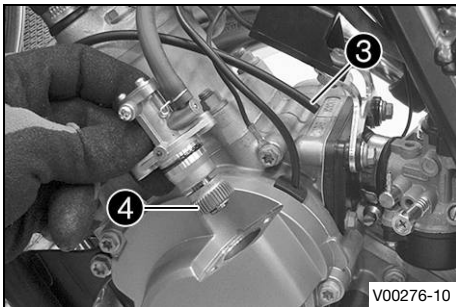

- Turn oil pump gear wheel ④ counterclockwise until oil flows out of oil line ③ without bubbles.

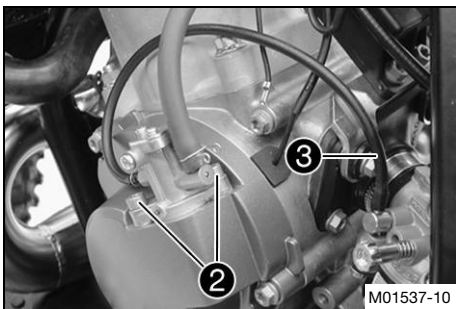

- Connect oil line ③.
- Position the oil pump.
- Mount and tighten screws ②.

Guideline

Screw, oil pump	M5	6 Nm (4.4 lbf ft)
-----------------	----	-------------------

## 16.3 Checking the gear oil level

**Condition**

The engine is cold.

**Preparatory work**

- Stand the motorcycle upright on a horizontal surface.

**Main work**

**(TC 50 MINI)**

- Remove screw ①.
- Check the gear oil level.

A small quantity of gear oil must run out of the drilled hole.

- » If no gear oil runs out:
  - Add the gear oil. 📖 (p. 115)

- Mount and tighten screw ①.

Guideline

Screw, gear oil level monitoring	M6	6 Nm (4.4 lbf ft)
----------------------------------	----	-------------------

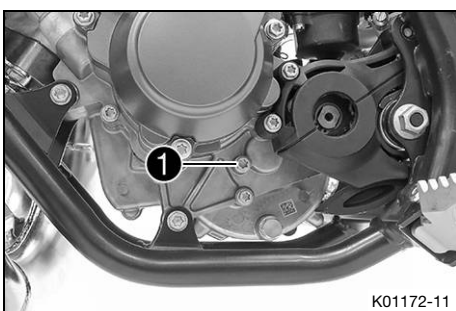

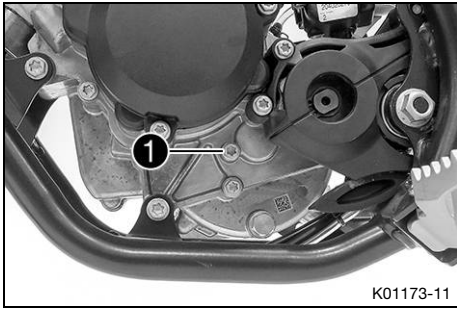

**(TC 50)**

- Remove screw ①.
- Check the gear oil level.

A small quantity of gear oil must run out of the drilled hole.

- » If no gear oil runs out:
  - Add the gear oil. ↗ (p. 115)
- Mount and tighten screw ①.

**Guideline**

Screw, gear oil level monitoring	M6	6 Nm (4.4 lbf ft)
----------------------------------	----	-------------------

## 16.4 Changing the gear oil ↗



**Warning**

**Danger of scalding** Engine and gear oil get very hot when the motorcycle is ridden.

- Wear suitable protective clothing and safety gloves.
- In the event of scalding, rinse the area affected immediately with lukewarm water.



**Note**

**Environmental hazard** Hazardous substances cause environmental damage.

- Dispose of oils, grease, filters, fuel, cleaning agents, brake fluid, etc., correctly and in compliance with the applicable regulations.



**Info**

Drain gear oil with engine at operating temperature.

**Preparatory work**

- Stand the motorcycle on the plug-in stand on a horizontal surface.

**Main work  
(TC 50 MINI)**

- Position an appropriate container under the engine.
- Remove oil drain plug ① with the magnet.
- Let the gear oil drain fully.
- Thoroughly clean the oil drain plug with magnet.
- Clean the sealing surface on the engine.
- Mount and tighten the oil drain plug with the magnet and new seal ring.

**Guideline**

Oil drain plug with magnet	M12x1.5	20 Nm (14.8 lbf ft)
----------------------------	---------	---------------------

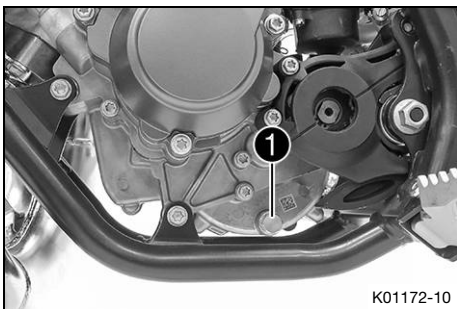

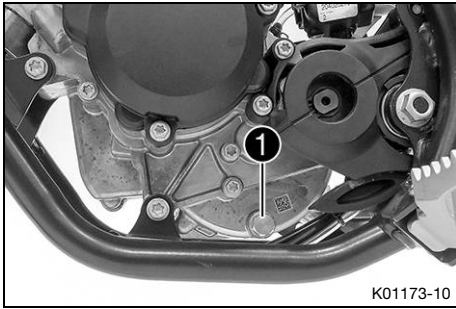

**(TC 50)**

- Position an appropriate container under the engine.
- Remove oil drain plug ① with the magnet.
- Let the gear oil drain fully.
- Thoroughly clean the oil drain plug with magnet.
- Clean the sealing surface on the engine.
- Mount and tighten the oil drain plug with the magnet and new seal ring.

**Guideline**

Oil drain plug with magnet	M12x1.5	20 Nm (14.8 lbf ft)
----------------------------	---------	---------------------

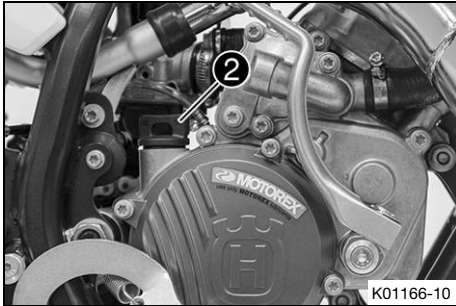

- Remove filler plug ② with the O-ring, and fill up with gear oil.

Gear oil	0.20 l (0.21 qt.)	Gear oil (ATF Dexron 3) (📖 p. 138)
----------	----------------------	--

**i Info**

Too little gear oil or poor-quality gear oil results in premature wear to the transmission.

- Mount and tighten filler plug ② with the O-ring.

**⚠ Danger**

**Danger of poisoning** Exhaust gases are toxic and inhaling them may result in unconsciousness and death.

- Always make sure there is sufficient ventilation when running the engine.
- Use effective exhaust extraction when starting or running the engine in an enclosed space.

- Start the engine and check for leaks.

**Finishing work**

- Check the gear oil level. (📖 p. 113)

## 16.5 Adding the gear oil ↩

**i Info**

Too little gear oil or poor-quality gear oil results in premature wear to the transmission.

**Preparatory work**

- Stand the motorcycle upright on a horizontal surface.

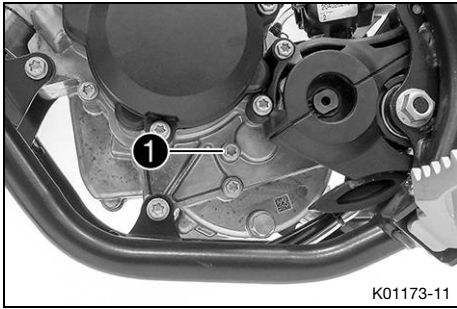

K01173-11

**Main work  
(TC 50)**

- Remove gear oil level monitoring screw ①.

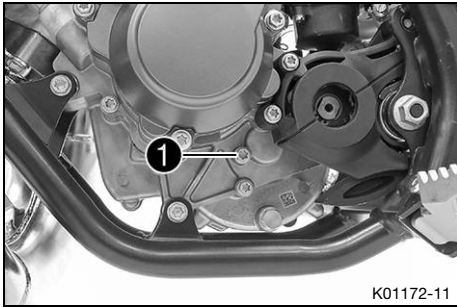

K01172-11

**(TC 50 MINI)**

- Remove gear oil level monitoring screw ①.

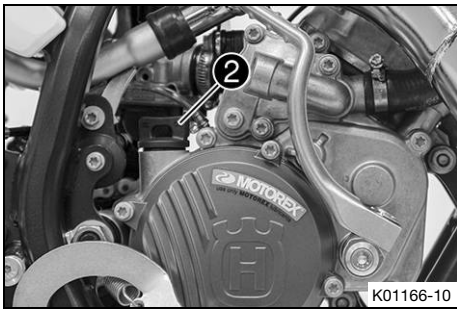

K01166-10

- Remove filler plug ② with the O-ring.
- Add gear oil until it flows out of the hole of the gear oil level plug.

Gear oil (ATF Dexron 3) (📖 p. 138)

- Mount and tighten gear oil level monitoring screw ①.

**Guideline**

Screw, gear oil level monitoring	M6	6 Nm (4.4 lbf ft)
----------------------------------	----	-------------------

- Mount and tighten filler plug ② with the O-ring.



**Danger**

**Danger of poisoning** Exhaust gases are toxic and inhaling them may result in unconsciousness and death.

- Always make sure there is sufficient ventilation when running the engine.
- Use effective exhaust extraction when starting or running the engine in an enclosed space.

- Start the engine and check for leaks.

## 17.1 Removing the carburetor ↘ (TC 50 MINI)



### Danger

**Fire hazard** Fuel is highly flammable.

The fuel in the fuel tank expands when warm and can escape if overfilled.

- Do not fuel the vehicle in the vicinity of open flames or lit cigarettes.
- Switch off the engine for refueling.
- Make sure that no fuel is spilled; particularly not on hot parts of the vehicle.
- If any fuel is spilled, wipe it off immediately.
- Observe the specifications for refueling.



### Warning

**Danger of poisoning** Fuel is poisonous and a health hazard.

- Avoid skin, eye and clothing contact with fuel.
- Immediately consult a doctor if you swallow fuel.
- Do not inhale fuel vapors.
- In case of skin contact, rinse the affected area with plenty of water.
- Rinse the eyes thoroughly with water, and consult a doctor in case of fuel contact with the eyes.
- Change your clothing in case of fuel spills on them.
- Keep fuels correctly in a suitable canister, and out of the reach of children.

### Preparatory work

- Turn the knurled screw on the fuel tap all the way clockwise.

### Main work

- Pull off fuel hose ①.

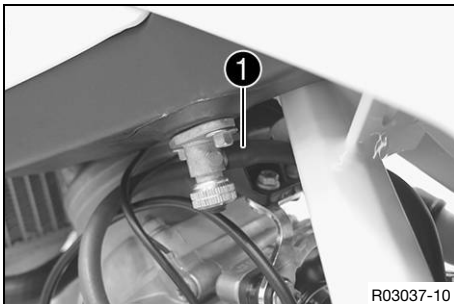

R03037-10



### Info

Remaining fuel may flow out of the fuel hose.



R03038-10

- Shut off the oil line.
- Close the oil line using a suitable object.

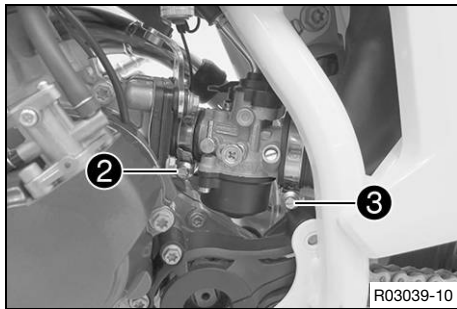

- Loosen hose clip ②.
- Loosen hose clip ③.
- Pull the carburetor out of the intake flange.
- Pull the carburetor forward out of the inlet sleeve.

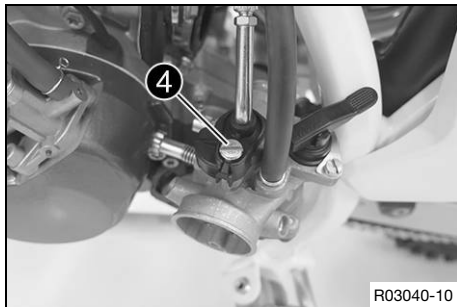

- Remove screw ④.
- Take off the throttle slide cover and pull the throttle slide out of the carburetor.
- Drain the remaining fuel.

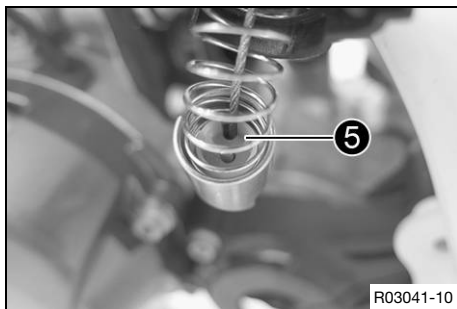

- Pull back spring retainer ⑤ and the throttle slide spring.
- Detach the throttle cable.

## 17.2 Removing the carburetor ↘ (TC 50)



### Danger

**Fire hazard** Fuel is highly flammable.

The fuel in the fuel tank expands when warm and can escape if overfilled.

- Do not fuel the vehicle in the vicinity of open flames or lit cigarettes.
- Switch off the engine for refueling.
- Make sure that no fuel is spilled; particularly not on hot parts of the vehicle.
- If any fuel is spilled, wipe it off immediately.
- Observe the specifications for refueling.



### Warning

**Danger of poisoning** Fuel is poisonous and a health hazard.

- Avoid skin, eye and clothing contact with fuel.
- Immediately consult a doctor if you swallow fuel.
- Do not inhale fuel vapors.
- In case of skin contact, rinse the affected area with plenty of water.
- Rinse the eyes thoroughly with water, and consult a doctor in case of fuel contact with the eyes.
- Change your clothing in case of fuel spills on them.
- Keep fuels correctly in a suitable canister, and out of the reach of children.



## Preparatory work

- Turn the knurled screw on the fuel tap all the way clockwise.

## Main work

- Pull off fuel hose ①.

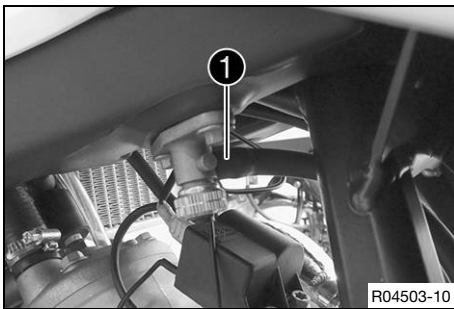

### Info

Remaining fuel may flow out of the fuel hose.

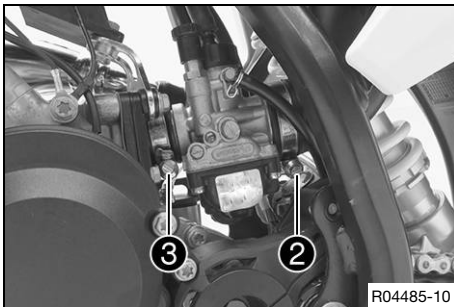

- Loosen hose clip ②.
- Loosen hose clip ③.

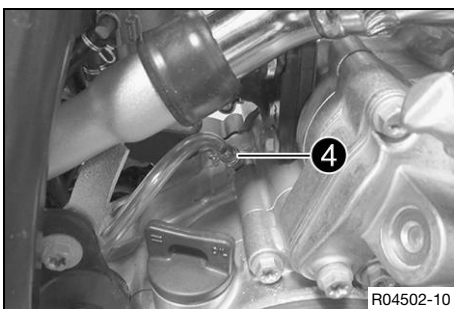

- Push back hose clamp ④ and pull off the vent hose.
- Pull the carburetor out of the intake flange.
- Pull the carburetor forward out of the inlet sleeve.

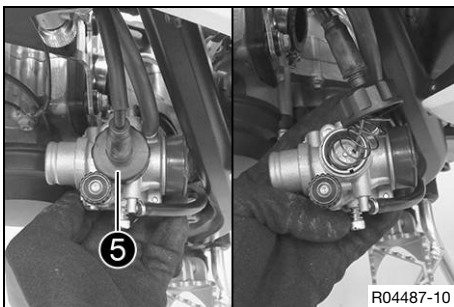

- Remove throttle slide cover ⑤.
- Pull the throttle slide out of the carburetor.
- Drain the remaining fuel.

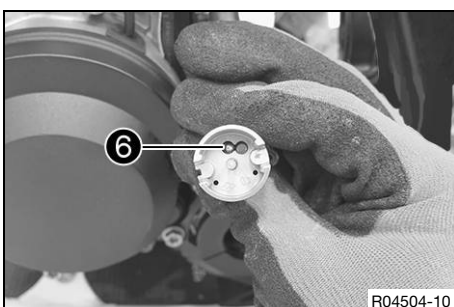

- Pull back the spring retainer and throttle slide spring.
- Detach throttle cable wire ⑥.
- Take off the throttle slide.

## 17.3 Installing the carburetor ↘ (TC 50 MINI)

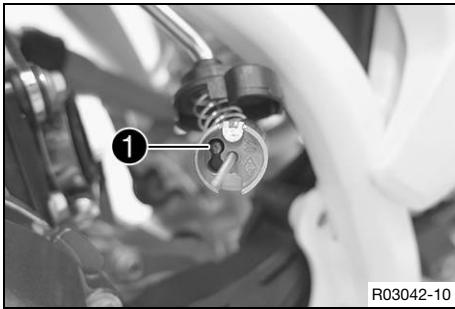

### Main work

- Attach throttle cable wire ①.

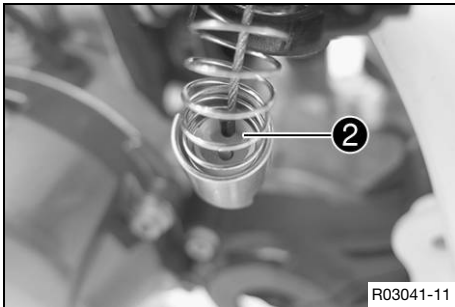

- Position spring retainer ②.
- Position the throttle slide spring.



- Position the throttle slide and throttle slide cover.
- Mount and tighten screw ③.

### Guideline

Screw, throttle slide cover	M5	1.3 Nm (0.96 lbf ft)
-----------------------------	----	----------------------

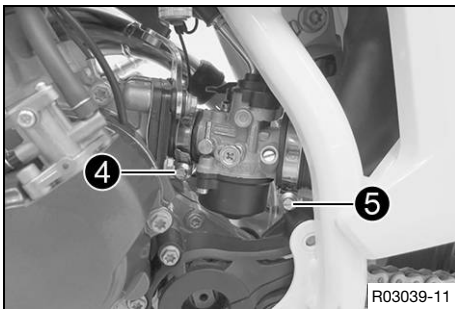

- Mount the carburetor.
- Position and tighten hose clip ④.

### Guideline

Hose clip, carburetor	-	2.8 Nm (2.07 lbf ft)
-----------------------	---	----------------------

- Position and tighten hose clip ⑤.

### Guideline

Hose clip, carburetor	-	2.8 Nm (2.07 lbf ft)
-----------------------	---	----------------------

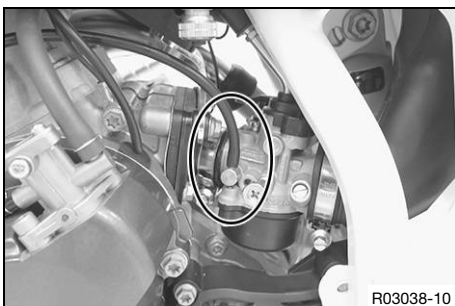

- Remove the plug.
- Connect the oil line.

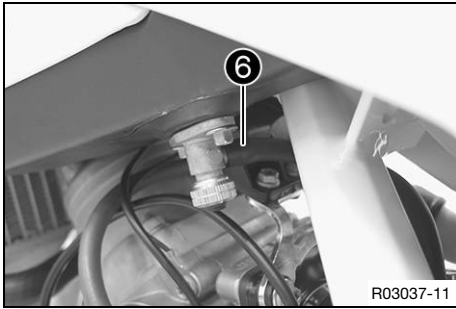

- Connect fuel hose ⑥.

### Finishing work

- Bleed the oil pump. 📖 (p. 112)
- Check the throttle cable play. 📖 (p. 105)
- Carburetor – adjust the idle speed. 📖 (p. 108)



## 17.4 Installing the carburetor 📖 (TC 50)

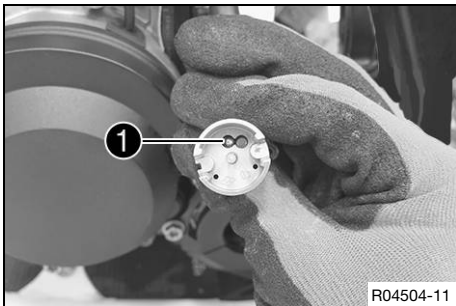

### Main work

- Attach throttle cable wire ①.
- Position the spring retainer and throttle slide spring.

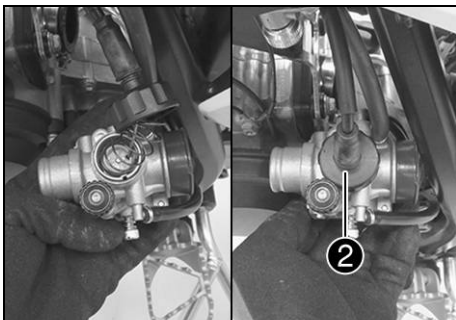

- Position the throttle slide and throttle slide cover.
- Tighten throttle slide cover ② hand-tight.
- Measure the distance between the carburetor housing and the throttle slide cover.
  - » Distance **A**:  $\leq 3 \text{ mm}$  ( $\leq 0.12 \text{ in}$ )
  - If the specified value is not reached:
    - Screw on the throttle slide cover correctly.

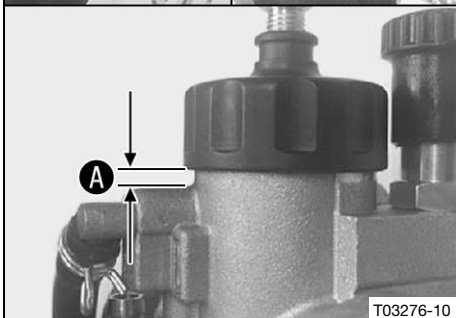

# 17 CARBURETOR

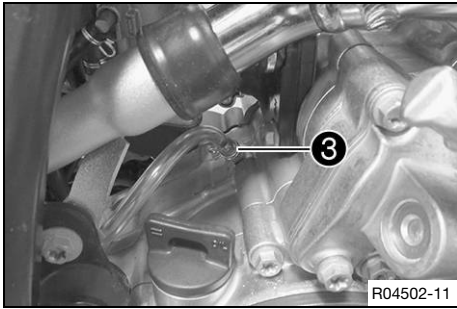

- Mount the carburetor.
- Mount the engine breather hose and position clamp ③.

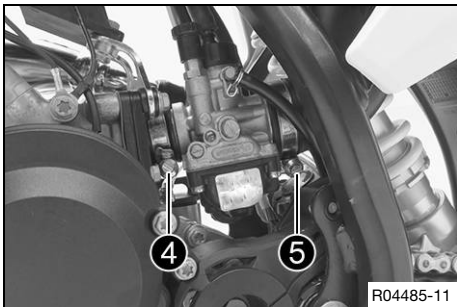

- Mount the inlet sleeve.
- Position and tighten hose clip ④.

Guideline

Hose clip, carburetor	-	2.8 Nm (2.07 lbf ft)
-----------------------	---	----------------------

- Position and tighten hose clip ⑤.

Guideline

Hose clip, carburetor	-	2.8 Nm (2.07 lbf ft)
-----------------------	---	----------------------



- Mount fuel hose ⑥.

## Finishing work

- Check the throttle cable play. (📖 p. 105)
- Carburetor - adjust the idle speed. 🛠️ (📖 p. 107)

## 18.1 Cleaning the motorcycle

### Note

**Material damage** Components become damaged or destroyed if a pressure cleaner is used incorrectly. The high pressure forces water into the electrical components, connectors, throttle cables, and bearings, etc. Pressure which is too high causes malfunctions and destroys components.

- Do not direct the water jet directly on to electrical components, connectors, throttle cables or bearings.
- Maintain a minimum distance between the nozzle of the pressure cleaner and the component.  
Minimum clearance 60 cm (23.6 in)



### Note

**Environmental hazard** Hazardous substances cause environmental damage.

- Dispose of oils, grease, filters, fuel, cleaning agents, brake fluid, etc., correctly and in compliance with the applicable regulations.



### Info

Clean the motorcycle regularly to maintain its value and appearance over a long period. Avoid direct sunshine when cleaning the motorcycle.

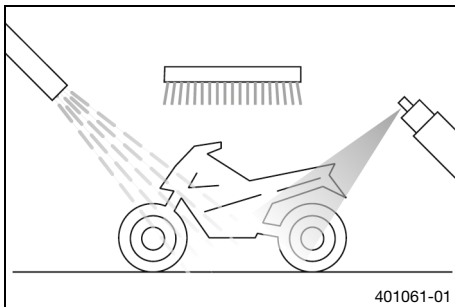

- Close off the exhaust system to keep water from entering.
- Remove loose dirt first with a soft jet of water.
- Spray heavily soiled parts with a normal commercial motorcycle cleaner and then brush off with a soft brush.

Motorcycle cleaner (📖 p. 139)



### Info

Use warm water containing normal motorcycle cleaner and a soft sponge. Never apply motorcycle cleaner to a dry vehicle; always rinse the vehicle with water first.

- After rinsing the motorcycle with a gentle spray of water, allow it to dry thoroughly.
- Remove the closure of the exhaust system.
- Empty the carburetor float chamber. 🗑️



### Warning

**Danger of accidents** Moisture and dirt impair the brake system.

- Explain to your child that he or she must brake carefully several times to dry out and remove dirt from the brake linings and the brake discs.

- After cleaning, your child should ride the vehicle a short distance until the engine warms up and until the brakes system has dried through careful application of the brakes.

---

**i Info**

The heat produced causes water at inaccessible locations in the engine and on the brake system to evaporate.

---

- Push back the protection caps on the handlebar controls to allow water to evaporate.
- After the motorcycle has cooled off, lubricate all moving parts and pivot points.
- Clean the chain. (📖 p. 66)
- Treat bare metal (except for brake discs and the exhaust system) with a corrosion inhibitor.

Preserving materials for paints, metal and rubber  
(📖 p. 139)

- Treat all plastic parts and powder-coated parts with a mild cleaning and care product.

Special cleaner for glossy and matte paint finishes, metal and plastic surfaces (📖 p. 140)

---

## 19.1 Storage



### Warning

**Danger of poisoning** Fuel is poisonous and a health hazard.

- Avoid skin, eye and clothing contact with fuel.
- Immediately consult a doctor if you swallow fuel.
- Do not inhale fuel vapors.
- In case of skin contact, rinse the affected area with plenty of water.
- Rinse the eyes thoroughly with water, and consult a doctor in case of fuel contact with the eyes.
- Change your clothing in case of fuel spills on them.
- Keep fuels correctly in a suitable canister, and out of the reach of children.



### Info

If the motorcycle is not being used for an extended period, additional measures are recommended. Before storing the motorcycle, check all parts for function and wear. If service, repairs, or replacements are necessary, you should do this during the storage period (less workshop overload). This allows you to avoid long waiting periods when the next season starts.

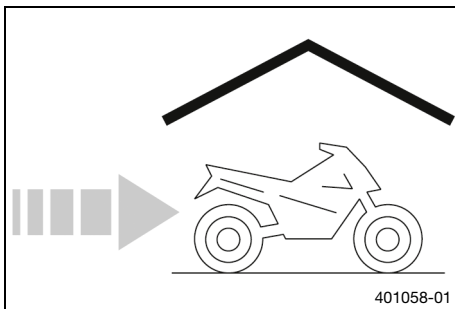

- When refueling for the last time before taking the motorcycle out of service, add fuel additive.

Fuel additive (📖 p. 139)

- Refuel. (📖 p. 25)
- Clean the motorcycle. (📖 p. 123)
- Change the gear oil. 🛠️ (📖 p. 114)
- Check the antifreeze and coolant level. (📖 p. 100)
- Empty the carburetor float chamber. 🛠️
- Check tire pressure. (📖 p. 98)
- Store the vehicle in a dry location that is not subject to large fluctuations in temperature.



### Info

Husqvarna Motorcycles recommends raising the motorcycle.

- Raise the motorcycle with a lift stand. (📖 p. 41)
- Cover the vehicle with a tarp or similar cover that is permeable to air.



### Info

Do not use non-porous materials since they prevent humidity from escaping, thus causing corrosion. Avoid running the engine for a short time only. Because the engine will not warm up sufficiently, the water vapor produced during combustion will condense, causing engine parts and the exhaust system to rust.

## 19.2 Preparing for use after storage

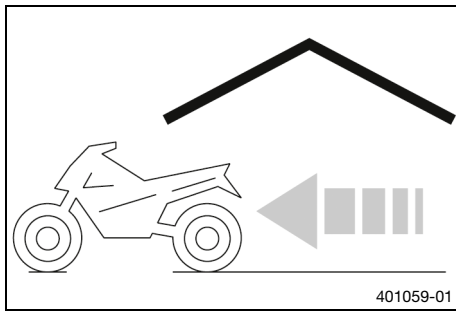

- Remove the motorcycle from the lift stand. (📖 p. 41)
- Perform checks and maintenance measures when preparing for use. (📖 p. 22)
- Take a test ride.



Faults	Possible cause	Action
Engine turns but does not start	Operating error	<ul style="list-style-type: none"> <li>- Carry out the start procedure. (📖 p. 22)</li> </ul>
	Motorcycle was out of use for a long time and there is old fuel in the float chamber	<ul style="list-style-type: none"> <li>- Empty the carburetor float chamber. 🛠️</li> </ul>
	Fuel supply interrupted	<ul style="list-style-type: none"> <li>- Check the fuel tank breather.</li> <li>- Clean the fuel tap.</li> </ul> <p><b>(TC 50)</b></p> <ul style="list-style-type: none"> <li>- Check/set the carburetor components. 🛠️</li> </ul> <p><b>(TC 50 MINI)</b></p> <ul style="list-style-type: none"> <li>- Check/set the carburetor components. 🛠️</li> </ul>
	Spark plug oily or wet	<ul style="list-style-type: none"> <li>- Clean and dry the spark plug, or change it if necessary.</li> </ul>
	Plug gap of spark plug too wide	<ul style="list-style-type: none"> <li>- Adjust plug gap.</li> </ul> <p>Guideline Spark plug electrode gap 0.60 mm (0.0236 in)</p>
	Fault in ignition system	<ul style="list-style-type: none"> <li>- Check the ignition system. 🛠️</li> </ul>
	Short-circuit cable in wiring harness frayed, switch-off button faulty	<ul style="list-style-type: none"> <li>- Check the switch-off button. 🛠️</li> </ul>
	The connector or ignition coil is loose or oxidized	<ul style="list-style-type: none"> <li>- Clean the plug-in connection and treat it with contact spray.</li> </ul>
Engine has no idle speed	Water in carburetor or jets blocked	<p><b>(TC 50)</b></p> <ul style="list-style-type: none"> <li>- Check/set the carburetor components. 🛠️</li> </ul> <p><b>(TC 50 MINI)</b></p> <ul style="list-style-type: none"> <li>- Check/set the carburetor components. 🛠️</li> </ul>
	Idling jet blocked	<p><b>(TC 50)</b></p> <ul style="list-style-type: none"> <li>- Check/set the carburetor components. 🛠️</li> </ul> <p><b>(TC 50 MINI)</b></p> <ul style="list-style-type: none"> <li>- Check/set the carburetor components. 🛠️</li> </ul>
	Adjusting screws on the carburetor are in turned to the wrong position	<p><b>(TC 50)</b></p> <ul style="list-style-type: none"> <li>- Carburetor - adjust the idle speed. 🛠️ (📖 p. 107)</li> </ul> <p><b>(TC 50 MINI)</b></p> <ul style="list-style-type: none"> <li>- Carburetor - adjust the idle speed. 🛠️ (📖 p. 108)</li> </ul>
	Spark plug defective	<ul style="list-style-type: none"> <li>- Change spark plug.</li> </ul>
	Ignition system defective	<ul style="list-style-type: none"> <li>- Check the ignition coil. 🛠️</li> <li>- Check the spark plug connector. 🛠️</li> </ul>

Faults	Possible cause	Action
Engine does not speed up	The carburetor is flowing over because the float needle is dirty or worn	<b>(TC 50)</b> <ul style="list-style-type: none"> <li>– Check/set the carburetor components. 🛠️</li> </ul> <b>(TC 50 MINI)</b> <ul style="list-style-type: none"> <li>– Check/set the carburetor components. 🛠️</li> </ul>
	Loose carburetor jets	<b>(TC 50)</b> <ul style="list-style-type: none"> <li>– Check/set the carburetor components. 🛠️</li> </ul> <b>(TC 50 MINI)</b> <ul style="list-style-type: none"> <li>– Check/set the carburetor components. 🛠️</li> </ul>
	Fault in ignition system	– Check the ignition system. 🛠️
Engine has too little power	Fuel supply interrupted	<ul style="list-style-type: none"> <li>– Check the fuel tank breather.</li> <li>– Clean the fuel tap.</li> </ul> <b>(TC 50)</b> <ul style="list-style-type: none"> <li>– Check/set the carburetor components. 🛠️</li> </ul> <b>(TC 50 MINI)</b> <ul style="list-style-type: none"> <li>– Check/set the carburetor components. 🛠️</li> </ul>
	Air filter very dirty	– Clean the air filter and air filter box. 🛠️ (📖 p. 63)
	Exhaust system leaky, deformed or too little glass fiber yarn filling in main silencer	<ul style="list-style-type: none"> <li>– Check exhaust system for damage.</li> <li>– Change the glass fiber yarn filling of the main silencer. 🛠️ (📖 p. 64)</li> </ul>
	Ignition system defective	<ul style="list-style-type: none"> <li>– Check the ignition coil. 🛠️</li> <li>– Check the spark plug connector. 🛠️</li> </ul>
	Diaphragm or reed valve housing damaged	– Check the diaphragm and reed valve housing.
	Noticeable wear	– Overhaul the engine.
	Clutch engagement speed too low or too high	– Check the clutch setting. 🛠️ (📖 p. 109)
Engine stalls or is popping into the carburetor	Lack of fuel	<ul style="list-style-type: none"> <li>– Turn the knurled screw on the fuel tap all the way counterclockwise.</li> <li>– Refuel. (📖 p. 25)</li> </ul>
	Engine takes in bad air	– Check the intake flange and carburetor for tightness.
	The connector or ignition coil is loose or oxidized	– Clean the plug-in connection and treat it with contact spray.
Engine overheats	Too little coolant in cooling system	<ul style="list-style-type: none"> <li>– Check the cooling system for leakage.</li> <li>– Check the coolant level. (📖 p. 101)</li> </ul>
	Too little air stream	– Switch off engine when standing.
	Radiator fins very dirty	– Clean radiator fins.
	Foam formation in cooling system	<ul style="list-style-type: none"> <li>– Drain the coolant. 🛠️ (📖 p. 101)</li> <li>– Refill with coolant. 🛠️ (📖 p. 102)</li> </ul>
	Damaged cylinder head or cylinder head gasket	– Check the cylinder head or cylinder head gasket.

Faults	Possible cause	Action
Engine overheats	Bent radiator hose	– Change the radiator hose. 🛠️
White smoke emission (steam in exhaust gas)	Damaged cylinder head or cylinder head gasket	– Check the cylinder head or cylinder head gasket.
Gear oil exits at the vent hose	Too much gear oil added	– Check the gear oil level. (📖 p. 113)
Water in the gear oil	Damaged radial shaft seal ring or water pump	– Check the radial shaft seal ring and the water pump.

## 21.1 Engine

Design	1-cylinder 2-stroke engine, water-cooled, with reed intake
Displacement	49.0 cm <sup>3</sup> (2.99 cu in)
Stroke	40 mm (1.57 in)
Bore	39.5 mm (1.555 in)
Crankshaft bearing	2 grooved ball bearings
Conrod bearing	Needle bearing
Piston pin bearing	Needle bearing
Pistons	Aluminum cast
Piston rings	1 rectangular ring
Engine lubrication (TC 50)	Mixed lubrication
Engine lubrication (TC 50 MINI)	Separate lubrication
Primary transmission	33:61 straight cut spur gear wheel drive
Clutch	Multi-disc centrifugal force clutch on the main shaft
Gearbox	Rigid 1-stage reduction gear
Transmission ratio	14:31
Ignition	SELETTA 2p D36
Spark plug	NGK LR 8 B
Spark plug electrode gap	0.60 mm (0.0236 in)
Cooling	Water-cooled
Starting aid	Kick starter system

## 21.2 Engine tightening torques

Screw, bearing retainer	M5	5 Nm (3.7 lbf ft)	
Screw, kick starter lever	M5	6 Nm (4.4 lbf ft)	<b>Loctite®243™</b>
Screw, oil pump (TC 50 MINI)	M5	6 Nm (4.4 lbf ft)	
Screw, stator clamp	M5	6 Nm (4.4 lbf ft)	<b>Loctite® 222™</b>
Screw, water pump impeller	M5	2 Nm (1.5 lbf ft)	<b>Loctite®243™</b>
Bleeder flange of engine case	M6	4 Nm (3 lbf ft)	<b>Loctite®243™</b>
Drain plug, water pump cover	M6	6 Nm (4.4 lbf ft)	
Screw, alternator cover	M6	6 Nm (4.4 lbf ft)	
Screw, clutch cover	M6	10 Nm (7.4 lbf ft)	
Screw, engine case	M6	10 Nm (7.4 lbf ft)	
Screw, engine sprocket cover	M6	10 Nm (7.4 lbf ft)	
Screw, exhaust flange	M6	10 Nm (7.4 lbf ft)	<b>Loctite®243™</b>
Screw, fitting pin	M6	10 Nm (7.4 lbf ft)	<b>Loctite®2701™</b>
Screw, gear oil level monitoring	M6	6 Nm (4.4 lbf ft)	
Screw, ground wire	M6	6 Nm (4.4 lbf ft)	

Screw, ignition coil	M6	4 Nm (3 lbf ft) <b>Loctite®243™</b>
Screw, intake flange	M6	5 Nm (3.7 lbf ft) <b>Loctite®243™</b>
Screw, pressure plate	M6	10 Nm (7.4 lbf ft) <b>Loctite®243™</b>
Screw, water pump cover	M6	10 Nm (7.4 lbf ft)
Screw, cylinder head	M7	18 Nm (13.3 lbf ft)
Nuts, cylinder base	M8	20 Nm (14.8 lbf ft)
Screw, clutch basket	M8	35 Nm (25.8 lbf ft)
Stud bolt, cylinder base	M8	10 Nm (7.4 lbf ft)
Spark plug	M10x1	10 ... 12 Nm (7.4 ... 8.9 lbf ft)
Nut, primary gear wheel	M10x1.25	40 Nm (29.5 lbf ft) <b>Loctite®243™</b>
Nut, rotor	M10x1.25	15 Nm (11.1 lbf ft) <b>Loctite®243™</b>
Oil drain plug with magnet	M12x1.5	20 Nm (14.8 lbf ft)

### 21.3 Carburetor with carburetor tuning

#### 21.3.1 TC 50

Carburetor type	Dell'Orto PHBG 19BS
Needle position	2nd position from top
Idle air adjusting screw	
Open	3 turns
Main jet	95
Jet needle	W7
Idling jet	50
Needle jet	262AU
Throttle slide	40
Choke nozzle	60

#### 21.3.2 TC 50 MINI

Carburetor type	Dell'Orto PHVA 12XS
Needle position	3rd position from top
Idle air adjusting screw	
Open	1 turn
Main jet	65
Jet needle	A8
Idling jet	30
Needle jet	211FA
Throttle slide	40
Choke nozzle	60

## 21.4 Capacities

### 21.4.1 Gear oil

Gear oil	0.20 l (0.21 qt.)	Gear oil (ATF Dexron 3) (📖 p. 138)
----------	-------------------	------------------------------------

### 21.4.2 Coolant

Coolant	0.7 l (0.7 qt.)	Coolant (📖 p. 137)
---------	-----------------	--------------------

### 21.4.3 Fuel

Fuel tank capacity, approx. (TC 50)	2.3 l (2.4 qt.)	Super unleaded (95 octane) mixed with 2-stroke engine oil (1:60) (📖 p. 138)
Fuel tank capacity, approx. (TC 50 MINI)	2.1 l (2.2 qt.)	Super unleaded (ROZ 95/RON 95/PON 91) (📖 p. 138)

## 21.5 Chassis

Frame	Central tube frame of chrome molybdenum steel tubing, powder-coated	
Fork (TC 50)	<b>WP XACT 5235</b>	
Fork (TC 50 MINI)	<b>WP XACT 5035</b>	
Shock absorber (TC 50)	<b>WP XACT 5735</b>	
Shock absorber (TC 50 MINI)	<b>WP XACT 5435</b>	
Suspension travel (TC 50)		
front	205 mm (8.07 in)	
rear	185 mm (7.28 in)	
Suspension travel (TC 50 MINI)		
front	100 mm (3.94 in)	
rear	147 mm (5.79 in)	
Fork offset	22 mm (0.87 in)	
Brake system		
front	Disc brake with 4-piston brake caliper	
rear	Disc brake with 2-piston brake caliper	
Brake disc diameters		
front	160 mm (6.3 in)	
rear	160 mm (6.3 in)	
Brake discs - wear limits		
front	2.2 mm (0.087 in)	
rear	2.2 mm (0.087 in)	
Offroad tire pressure		
front	1.0 bar (15 psi)	
rear	1.0 bar (15 psi)	
Secondary drive ratio (TC 50)	11:40	
Secondary drive ratio (TC 50 MINI)	10:42	
Chain	1/2 x 3/16"	
Rear sprockets available	38, 39, 40, 41, 42	

Steering head angle (TC 50)	66°
Steering head angle (TC 50 MINI)	67.4°
Wheelbase (TC 50)	1,032 ± 10 mm (40.63 ± 0.39 in)
Wheelbase (TC 50 MINI)	914 ± 10 mm (35.98 ± 0.39 in)
Seat height unloaded (TC 50)	665 mm (26.18 in)
Seat height unloaded (TC 50 MINI)	558 mm (21.97 in)
Ground clearance unloaded (TC 50)	252 mm (9.92 in)
Ground clearance unloaded (TC 50 MINI)	184 mm (7.24 in)
Weight without fuel approx. (TC 50)	41.5 kg (91.5 lb.)
Weight without fuel approx. (TC 50 MINI)	40 kg (88 lb.)
Maximum rider weight	45 kg (99 lb.)

## 21.6 Tires

Validity	Front tire	Rear tire
(TC 50)	<b>60/100 - 12 36M TT</b> MAXXIS MAXX CROSS SI	<b>2.75 - 10 38J TT</b> MAXXIS MAXX CROSS SI
(TC 50 MINI)	<b>2.50 - 10 33J TT</b> MAXXIS MAXX CROSS SI	<b>2.75 - 10 38J TT</b> MAXXIS MAXX CROSS SI

The tires specified represent one of the possible series production tires. Additional information is available in the Service section under:  
[www.husqvarna-motorcycles.com](http://www.husqvarna-motorcycles.com)

## 21.7 Fork

### 21.7.1 TC 50

Fork article number	07.18.6U.02	
Fork	<b>WP XACT 5235</b>	
Rebound damping		
Comfort	15 clicks	
Standard	12 clicks	
Sport	10 clicks	
Air pressure	2 bar (29 psi)	
Fork length	685 mm (26.97 in)	
Spring length with preload spacer(s)	337.5 mm (13.287 in)	
Oil capacity external mechanism left	25 ± 5 ml (0.85 ± 0.17 fl. oz.)	Fork oil (SAE 4) (48601166S1) (📖 p. 137)
Oil capacity, right cartridge	225 ml (7.61 fl. oz.)	Fork oil (SAE 4) (48601166S1) (📖 p. 137)
Grease capacity, left cartridge	6 g (0.21 oz)	Special grease (00062010053) (📖 p. 140)

### 21.7.2 TC 50 MINI

Fork article number	07.18.1U.01	
Fork	<b>WP XACT 5035</b>	
Fork length	580 mm (22.83 in)	

Spring rate		
Weight of rider: 15 ... 25 kg (33 ... 55 lb.)	1.8 N/mm (10.3 lb/in)	
Weight of rider (standard): 25 ... 35 kg (55 ... 77 lb.)	2.0 N/mm (11.4 lb/in)	
Weight of rider: 35 ... 45 kg (77 ... 99 lb.)	2.2 N/mm (12.6 lb/in)	
Spring length with preload spacer(s)	337.5 mm (13.287 in)	
Fork oil per fork leg	230 ± 10 ml (7.78 ± 0.34 fl. oz.)	Fork oil (SAE 4) (48601166S1)  p. 137

## 21.8 Shock absorber

### 21.8.1 TC 50

Shock absorber article number	03.18.7U.02	
Shock absorber	<b>WP XACT 5735</b>	
Low-speed compression damping		
Comfort	18 clicks	
Standard	15 clicks	
Sport	12 clicks	
High-speed compression damping		
Comfort	2.5 turns	
Standard	2 turns	
Sport	1.5 turns	
Rebound damping		
Comfort	17 clicks	
Standard	15 clicks	
Sport	13 clicks	
Spring preload	3 mm (0.12 in)	
Spring rate		
Weight of rider: 15 ... 25 kg (33 ... 55 lb.)	25 N/mm (143 lb/in)	
Weight of rider (standard): 25 ... 35 kg (55 ... 77 lb.)	30 N/mm (171 lb/in)	
Weight of rider: 35 ... 45 kg (77 ... 99 lb.)	35 N/mm (200 lb/in)	
Spring length	130 mm (5.12 in)	
Gas pressure	10 bar (145 psi)	
Static sag	12 mm (0.47 in)	
Riding sag	80 mm (3.15 in)	
Fitted length	275 mm (10.83 in)	
Shock absorber oil	Shock absorber fluid (SAE 2.5) (50180751S1)  p. 138	

### 21.8.2 TC 50 MINI

Shock absorber article number	03.18.9T.01	
Shock absorber	<b>WP XACT 5435</b>	
Rebound damping		
Standard	12 clicks	



Spring preload	
Standard	5 mm (0.2 in)
Spring rate	
Weight of rider: 15 ... 25 kg (33 ... 55 lb.)	65 N/mm (371 lb/in)
Weight of rider (standard): 25 ... 35 kg (55 ... 77 lb.)	75 N/mm (428 lb/in)
Weight of rider: 35 ... 45 kg (77 ... 99 lb.)	85 N/mm (485 lb/in)
Spring length	120 mm (4.72 in)
Gas pressure	10 bar (145 psi)
Static sag	10 mm (0.39 in)
Riding sag	65 mm (2.56 in)
Fitted length	245 mm (9.65 in)
Shock absorber oil	Shock absorber fluid (SAE 2.5) (50180751S1) (📖 p. 138)

## 21.9 Chassis tightening torques

Hose clip, carburetor (TC 50 MINI)	-	2.8 Nm (2.07 lbf ft)
Hose clip, carburetor (TC 50)	-	2.8 Nm (2.07 lbf ft)
Screw, brake line bracket	<b>EJOT</b>	1.7 Nm (1.25 lbf ft)
Screw, brake line guide	<b>EJOT</b>	2 Nm (1.5 lbf ft)
Screw, side cover	<b>EJOT PT®</b> K60x20-Z	2 Nm (1.5 lbf ft)
Screw, switch-off button	M3	0.4 Nm (0.3 lbf ft)
Spoke nipple	M3.5	3 Nm (2.2 lbf ft)
Remaining nuts, chassis	M5	5 Nm (3.7 lbf ft)
Remaining screws, chassis	M5	5 Nm (3.7 lbf ft)
Screw, brake assembly	M5	5 Nm (3.7 lbf ft)
Screw, brake linings	M5	8 Nm (5.9 lbf ft)
Screw, throttle slide cover (TC 50 MINI)	M5	1.3 Nm (0.96 lbf ft)
Nut, push rod ball joint on foot brake cylinder	M6	10 Nm (7.4 lbf ft)
Nut, push rod, foot brake lever	M6	6 Nm (4.4 lbf ft)
Remaining nuts, chassis	M6	10 Nm (7.4 lbf ft)
Remaining screws, chassis	M6	10 Nm (7.4 lbf ft)
Screw, chain sliding piece	M6	3 Nm (2.2 lbf ft)
Screw, fender	M6	6 Nm (4.4 lbf ft)
Screw, fork stub	M6	10 Nm (7.4 lbf ft)
Screw, front brake disc	M6	14 Nm (10.3 lbf ft) <b>Loctite®243™</b>
Screw, main silencer silent block	M6	6 Nm (4.4 lbf ft)
Screw, rear brake caliper	M6x16	10 Nm (7.4 lbf ft) <b>Loctite®243™</b>
Screw, rear brake caliper	M6x40	10 Nm (7.4 lbf ft) <b>Loctite®243™</b>
Screw, rear brake disc	M6	14 Nm (10.3 lbf ft) <b>Loctite®243™</b>

## 21 TECHNICAL DATA

Screw, start number plate	M6	4 Nm (3 lbf ft)	
Screw, throttle grip	M6	4.5 Nm (3.32 lbf ft)	
Nut, foot brake lever	M8	22 Nm (16.2 lbf ft)	
Nut, rim lock	M8	10 Nm (7.4 lbf ft)	
Remaining nuts, chassis	M8	25 Nm (18.4 lbf ft)	
Remaining screws, chassis	M8	25 Nm (18.4 lbf ft)	
Screw, bottom triple clamp	M8	15 Nm (11.1 lbf ft)	
Screw, chain sliding piece	M8	15 Nm (11.1 lbf ft)	
Screw, engine bracket	M8	25 Nm (18.4 lbf ft)	<b>Loctite®243™</b>
Screw, engine sprocket cover	M8	15 Nm (11.1 lbf ft)	
Screw, front brake caliper	M8x60	20 Nm (14.8 lbf ft)	<b>Loctite®243™</b>
Screw, front brake caliper	M8x40	20 Nm (14.8 lbf ft)	<b>Loctite®243™</b>
Screw, handlebar clamp	M8	20 Nm (14.8 lbf ft)	
Screw, rear sprocket	M8	25 Nm (18.4 lbf ft)	<b>Loctite®243™</b>
Screw, steering stem	M8	20 Nm (14.8 lbf ft)	
Screw, top triple clamp	M8	20 Nm (14.8 lbf ft)	
Nut, link fork pivot	M10	45 Nm (33.2 lbf ft)	
Remaining nuts, chassis	M10	45 Nm (33.2 lbf ft)	
Remaining screws, chassis	M10	45 Nm (33.2 lbf ft)	
Screw, bottom shock absorber	M10	45 Nm (33.2 lbf ft)	<b>Loctite®243™</b>
Screw, front wheel spindle	M10	40 Nm (29.5 lbf ft)	<b>Loctite®243™</b>
Screw, handlebar support	M10	40 Nm (29.5 lbf ft)	<b>Loctite®243™</b>
Screw, top shock absorber	M10	45 Nm (33.2 lbf ft)	<b>Loctite®243™</b>
Nut, rear wheel spindle	M12x1	40 Nm (29.5 lbf ft)	
Nut, steering head	M20x1.5	10 Nm (7.4 lbf ft)	

**Brake fluid DOT 4 / DOT 5.1****Standard/classification**

- DOT

**Guideline**

- Use only brake fluid that complies with the specified standard (see specifications on the container) and that exhibits the corresponding properties.

**Recommended supplier****Castrol**

- REACT PERFORMANCE DOT 4

**MOTOREX®**

- Brake Fluid DOT 5.1

**Coolant****Guideline**

- Only use high-grade, silicate-free coolant with corrosion inhibitor additive for aluminum motors. Low grade and unsuitable antifreeze causes corrosion, deposits and frothing.
- Do not use pure water as only coolant is able to meet the requirements needed in terms of corrosion protection and lubrication properties.
- Only use coolant that complies with the requirements stated (see specifications on the container) and that has the relevant properties.

Antifreeze protection to at least	-25 °C (-13 °F)
-----------------------------------	-----------------

The mixture ratio must be adjusted to the necessary antifreeze protection. Use distilled water if the coolant needs to be diluted.

The use of premixed coolant is recommended.

Observe the coolant manufacturer specifications for antifreeze protection, dilution and miscibility (compatibility) with other coolants.

**Recommended supplier****MOTOREX®**

- COOLANT M3.0

**Engine oil, 2-stroke****Standard/classification**

- JASO FD (📖 p. 141)

**Guideline**

- Only use high grade 2-stroke engine oil of a reputable brand.

Fully synthetic
-----------------

**Recommended supplier****MOTOREX®**

- Cross Power 2T

**Fork oil (SAE 4) (48601166S1)****Standard/classification**

- SAE (📖 p. 141) (SAE 4)

**Guideline**

- Use only oils that comply with the specified standards (see specifications on the container) and that exhibit the corresponding properties.

## Gear oil (ATF Dexron 3)

### Standard/classification

- Dexron III (ATF Dexron 3)

### Guideline

- Use only ATF gear oils that comply with the specified standards (see specifications on the container) and that possess the necessary properties.

### Recommended supplier

**MOTOREX®**

- ATF Dexron 3

## Shock absorber fluid (SAE 2.5) (50180751S1)

### Standard/classification

- SAE (📖 p. 141) (SAE 2.5)

### Guideline

- Use only oils that comply with the specified standards (see specifications on the container) and that exhibit the corresponding properties.

## Super unleaded (ROZ 95/RON 95/PON 91)

### Standard/classification

- DIN EN 228 (ROZ 95/RON 95/PON 91)

### Guideline

- Only use unleaded super fuel that matches or is equivalent to the specified fuel grade.
- Fuel with an ethanol content of up to 10 % (E10 fuel) is safe to use.



### Info

Do **not** use fuel containing methanol (e. g. M15, M85, M100) or more than 10 % ethanol (e. g. E15, E25, E85, E100).

## Super unleaded (95 octane) mixed with 2-stroke engine oil (1:60)

### Standard/classification

- DIN EN 228
- JASO FD (📖 p. 141) (1:60)

### Mixture ratio

1:60	Engine oil, 2-stroke (📖 p. 137) Super unleaded (ROZ 95/RON 95/PON 91) (📖 p. 138)
------	---

### Recommended supplier

**MOTOREX®**

- Cross Power 2T

**Air filter cleaner**

Recommended supplier

**MOTOREX®**

- Racing Bio Dirt Remover

**Chain cleaner**

Recommended supplier

**MOTOREX®**

- Chain Clean

**Fuel additive**

Recommended supplier

**MOTOREX®**

- Fuel Stabilizer

**High viscosity grease**

Recommended supplier

**SKF®**

- LGHB 2

**Long-life grease**

Recommended supplier

**MOTOREX®**

- Bike Grease 2000

**Motorcycle cleaner**

Recommended supplier

**MOTOREX®**

- Moto Clean

**Off-road chain spray**

Recommended supplier

**MOTOREX®**

- Chainlube Offroad

**Oil for foam air filter**

Recommended supplier

**MOTOREX®**

- Racing Bio Liquid Power

**Preserving materials for paints, metal and rubber**

Recommended supplier

**MOTOREX®**

- Moto Protect

### Rubber grip adhesive (00062030051)

Recommended supplier

KTM AG

- GRIP GLUE

### Special cleaner for glossy and matte paint finishes, metal and plastic surfaces

Recommended supplier

MOTOREX®

- Quick Cleaner

### Special grease (00062010053)

Recommended supplier

Klüber Lubrication®

- KLÜBERFOOD NH1 34-401

### Universal oil spray

Recommended supplier

MOTOREX®

- Joker 440 Synthetic

**JASO FD**

JASO FD is a classification for a 2-stroke engine oil that was specifically developed for the extreme demands of racing. Thanks to first-rate synthetic esters and specially designed additives, superb combustion is achieved even under extreme operating conditions.

**SAE**

The SAE viscosity classes were defined by the Society of Automotive Engineers and are used for classifying oils according to their viscosity. The viscosity describes only one property of oil and says nothing about quality.

## 25 LIST OF ABBREVIATIONS

Art. no.	Article number
ca.	circa
cf.	compare
e.g.	for example
etc.	et cetera
i.a.	inter alia
no.	number
poss.	possibly



<b>A</b>	
<b>Accessories</b>	9
<b>Air filter</b>	
cleaning	63
installing	62
removing	62
<b>Air filter box</b>	
cleaning	63
<b>Air suspension XACT 5235</b>	29
<b>Antifreeze</b>	
checking	100
<b>Auxiliary substances</b>	9
<b>B</b>	
<b>Basic chassis setting</b>	
rider's weight, checking with	29
<b>Brake discs</b>	
checking	77
<b>Brake fluid</b>	
front brake, adding	79
rear wheel brake, adding	86
<b>Brake fluid level</b>	
front brake, checking	78
rear brake, checking	85
<b>Brake linings</b>	
front brake, checking	80
of front brake, changing	80
of the rear brake, changing	88
of the rear brake, checking	87
<b>C</b>	
<b>Capacity</b>	
coolant	102, 104, 132
fuel	26, 132
gear oil	115, 132
<b>Carburetor</b>	
adjusting the idle speed	107
idle setting	106
idle speed, adjusting	108
installing	120-121
removing	117-118
<b>Chain</b>	
checking	69
cleaning	66
<b>Chain guide</b>	
adjusting	73
checking	69
<b>Chain tension</b>	
adjusting	68
checking	67
<b>Choke</b>	17
<b>Cleaning</b>	123-124
<b>Clutch</b>	
adjusting	110
setting, checking	109
<b>Clutch cover</b>	
clutch cover, installing	111
clutch cover, removing	109
<b>Coolant</b>	
changing	103
draining	101
refilling	102
<b>Coolant level</b>	
checking	100-101
<b>Cooling system</b>	100
<b>Customer service</b>	10
<b>D</b>	
<b>Dust boots</b>	
cleaning	42
<b>E</b>	
<b>Engine</b>	
running in	21
<b>Engine number</b>	13
<b>Engine sprocket</b>	
checking	69
<b>Engine sprocket cover</b>	
installing	65
removing	65
<b>Environment</b>	8
<b>F</b>	
<b>Figures</b>	9
<b>Foot brake lever</b>	18
basic position, adjusting	85
free travel, adjusting	84
free travel, checking	84
<b>Fork legs</b>	
air pressure, adjusting	37
basic setting, checking	37
bleeding	41
installing	44
removing	44
<b>Fork part number</b>	14
<b>Fork protector</b>	
installing	43

removing	43	<b>M</b>	
<b>Frame</b>		<b>Main silencer</b>	
checking	73	glass fiber yarn filling, changing	64
<b>Front fender</b>		installing	64
installing	55	removing	63
removing	54	<b>Manufacturer warranty</b>	9
<b>Front wheel</b>		<b>Misuse</b>	6
installing	93	<b>Motorcycle</b>	
removing	93	cleaning	123
<b>Fuel tank</b>		lift stand, raising with	41
installing	53	lift stand, removing from	41
removing	52	<b>O</b>	
<b>Fuel tank filler cap</b>		<b>Oil level</b>	
closing	16	checking	112
opening	15	<b>Oil pump</b>	
<b>Fuel tap</b>	17	bleeding	112
<b>Fuel, oils, etc.</b>	9	<b>Oil tank cap</b>	
<b>G</b>		closing	17
<b>Gear oil</b>		opening	16
adding	115	<b>Owner's Manual</b>	8
changing	114	<b>P</b>	
<b>Gear oil level</b>		<b>Plug-in stand</b>	18
checking	113	<b>Preparing for use</b>	
<b>H</b>		advice on preparing for first use	19
<b>Hand brake lever</b>	15	after storage	126
basic position, adjusting	76	checks and maintenance measures when	
checking play	76	preparing for use	22
play, adjusting	76	<b>Protective clothing</b>	8
<b>Handlebar position</b>	39	<b>R</b>	
adjusting	39	<b>Rear sprocket</b>	
<b>High-speed compression damping</b>		checking	69
shock absorber, adjusting	31	<b>Rear wheel</b>	
<b>I</b>		installing	96
<b>Implied warranty</b>	9	removing	94
<b>Intended use</b>	6	<b>Rebound damping</b>	
<b>K</b>		fork, adjusting	38
<b>Kick starter lever</b>	18	shock absorber, adjusting	31
<b>L</b>		<b>Refueling</b>	
<b>Link fork</b>		fuel	25
checking	73	oil	26
<b>Lower triple clamp</b>		<b>Riding sag</b>	
installing	47	adjusting	36
removing	46	<b>Right side cover</b>	
<b>Low-speed compression damping</b>		installing	56
shock absorber, adjusting	30	preparing for securing	57
		removing	55

<b>Rubber grip</b>	
checking	75
securing	75
<b>S</b>	
<b>Safe operation</b>	7
<b>Seat</b>	
mounting	61
removing	61
<b>Seat height</b>	
adjusting	40
<b>Service</b>	9
<b>Service hour counter</b>	18
<b>Service schedule</b>	27-28
<b>Shock absorber</b>	
installing	60
removing	59
riding sag, checking	34
spring preload, adjusting	34
static sag, checking	33
<b>Shock absorber article number</b>	14
<b>Side cover, left</b>	
installing	58
preparing for securing	59
removing	57
<b>Spare parts</b>	9
<b>Spoke tension</b>	
checking	99
<b>Start number plate</b>	
installing	54
removing	54
<b>Starting</b>	22
<b>Steering head bearing</b>	
lubricating	51
<b>Steering head bearing play</b>	
adjusting	50
checking	50
<b>Storage</b>	125
<b>Switch-off button</b>	15
<b>T</b>	
<b>Technical data</b>	
capacities	132
carburetor	131
chassis	132
chassis tightening torques	135
engine	130
engine tightening torques	130
fork	133
shock absorber	134
tires	133
<b>Throttle cable play</b>	
adjusting	105
checking	105
<b>Throttle cable routing</b>	
checking	74
<b>Throttle grip</b>	15
<b>Tire condition</b>	
checking	97
<b>Tire pressure</b>	
checking	98
<b>Transporting</b>	25
<b>Troubleshooting</b>	127-129
<b>Type label</b>	13
<b>U</b>	
<b>Use definition</b>	6
<b>V</b>	
<b>Vehicle identification number</b>	13
<b>View of vehicle</b>	
front left	11
rear right	12
<b>W</b>	
<b>Work rules</b>	8



3402435en

05/2020



Husqvarna Motorcycles GmbH  
Stallhofnerstraße 3 | 5230 Mattighofen | Austria  
[www.husqvarna-motorcycles.com](http://www.husqvarna-motorcycles.com)



Photo: Mitterbauer/KISKA,  
Husqvarna Motorcycles GmbH