



# OWNER'S MANUAL 2021

MC 65

Art. no. 3215006en



# **GASGAS**



Congratulations on your decision to purchase a GASGAS motorcycle. You are now the owner of a state-of-the-art sports vehicle that will continue to give you and your child pleasure for a long time if you maintain it properly.

We hope your child has many safe and enjoyable rides!

Enter the serial numbers of your vehicle below.

Vehicle identification number (📖 p. 12)	Dealer's stamp
Engine number (📖 p. 12)	

The Owner's Manual contained the latest information for this model series at the time of going to print. However, minor differences due to further developments in design cannot be ruled out completely.

All specifications contained herein are non-binding. GASGAS Motorcycles GmbH specifically reserves the right to modify or delete technical specifications, prices, colors, forms, materials, services, designs, equipment, etc., without prior notice and without specifying reasons, to adapt these to local conditions, as well as to stop production of a particular model without prior notice. GASGAS Motorcycles accepts no liability for delivery options, deviations from figures and descriptions, as well as misprints and other errors. The models portrayed partly contain special equipment that does not belong to the regular scope of supply.

© 2023 GASGAS GmbH, Mattighofen Austria

All rights reserved

Reproduction, even in part, as well as copying of all kinds, is permitted only with the express written permission of the copyright owner.



ISO 9001(12 100 6061)

GASGAS applies quality assurance processes that lead to the highest possible product quality as defined in the ISO 9001 international quality management standard.

Issued by: TÜV SÜD Management Service GmbH

REG.NO. 12 100 6061

GASGAS GmbH

Stallhofnerstraße 3











5230 Mattighofen, Austria

This document is valid for the following models:

MC 65 (F0001U6)



# TABLE OF CONTENTS

1	MEANS OF REPRESENTATION .....	5	8.2	Starting the vehicle .....	21
1.1	Symbols used .....	5	8.3	Starting off .....	22
1.2	Formats used .....	5	8.4	Shifting, riding .....	22
2	SAFETY ADVICE .....	6	8.5	Applying the brakes .....	23
2.1	Use definition – intended use .....	6	8.6	Stopping, parking .....	23
2.2	Misuse .....	6	8.7	Transporting .....	24
2.3	Safety advice .....	6	8.8	Refueling .....	24
2.4	Degrees of risk and symbols .....	6	9	SERVICE SCHEDULE .....	26
2.5	Tampering warning .....	6	9.1	Additional information .....	26
2.6	Safe operation .....	7	9.2	Required work .....	26
2.7	Protective clothing .....	7	9.3	Recommended work .....	27
2.8	Work rules .....	8	10	TUNING THE CHASSIS .....	28
2.9	Environment .....	8	10.1	Checking the basic chassis setting with rider's weight .....	28
2.10	Owner's Manual .....	8	10.2	Air suspension .....	28
3	IMPORTANT NOTES .....	9	10.3	Compression damping of the shock absorber .....	29
3.1	Manufacturer warranty, implied warranty .....	9	10.4	Adjusting the low-speed compression damping of the shock absorber .....	29
3.2	Fuel, auxiliary substances .....	9	10.5	Adjusting the high-speed compression damping of the shock absorber .....	29
3.3	Spare parts, accessories .....	9	10.6	Adjusting the rebound damping of the shock absorber .....	30
3.4	Service .....	9	10.7	Measuring the dimension of the rear wheel unloaded .....	30
3.5	Figures .....	9	10.8	Checking the static sag of the shock absorber .....	31
3.6	Customer service .....	9	10.9	Checking the riding sag of the shock absorber .....	32
4	VIEW OF VEHICLE .....	10	10.10	Adjusting the spring preload of the shock absorber  .....	32
4.1	View of vehicle, front left (example) .....	10	10.11	Adjusting the riding sag  .....	33
4.2	View of vehicle, rear right (example) .....	11	10.12	Checking the basic setting of the fork .....	34
5	SERIAL NUMBERS .....	12	10.13	Adjusting the fork air pressure .....	34
5.1	Vehicle identification number .....	12	10.14	Adjusting the rebound damping of the fork .....	35
5.2	Type label .....	12	10.15	Handlebar position .....	36
5.3	Engine number .....	12	10.16	Adjusting the handlebar position  .....	36
5.4	Fork article number .....	12	11	SERVICE WORK ON THE CHASSIS .....	37
5.5	Shock absorber article number .....	13	11.1	Raising the motorcycle with a lift stand .....	37
6	CONTROLS .....	14	11.2	Removing the motorcycle from the lift stand .....	37
6.1	Clutch lever .....	14	11.3	Bleeding the fork legs .....	37
6.2	Hand brake lever .....	14	11.4	Cleaning the dust boots of the fork legs .....	38
6.3	Throttle grip .....	14	11.5	Removing the fork protector .....	39
6.4	Stop button .....	14	11.6	Installing the fork protector .....	39
6.5	Opening the fuel tank filler cap .....	15	11.7	Removing the fork legs  .....	40
6.6	Closing the fuel tank filler cap .....	15	11.8	Installing the fork legs  .....	40
6.7	Fuel tap .....	16	11.9	Removing the lower triple clamp  .....	41
6.8	Choke .....	16	11.10	Installing the lower triple clamp  .....	42
6.9	Shift lever .....	16	11.11	Checking the steering head bearing play .....	44
6.10	Kick starter lever .....	17	11.12	Adjusting the steering head bearing play  .....	44
6.11	Foot brake lever .....	17	11.13	Lubricating the steering head bearing  .....	45
6.12	Plug-in stand .....	17	11.14	Removing the fuel tank  .....	45
7	PREPARING FOR USE .....	18			
7.1	Advice on preparing for first use .....	18			
7.2	Running in the engine .....	19			
8	RIDING INSTRUCTIONS .....	21			
8.1	Checks and maintenance measures when preparing for use .....	21			

11.15	Installing the fuel tank	46	13	WHEELS, TIRES	76
11.16	Removing the start number plate	47	13.1	Removing the front wheel	76
11.17	Installing the start number plate	48	13.2	Installing the front wheel	76
11.18	Removing front fender	48	13.3	Removing the rear wheel	77
11.19	Installing front fender	48	13.4	Installing the rear wheel	78
11.20	Removing the shock absorber	49	13.5	Checking the tire condition	79
11.21	Installing the shock absorber	49	13.6	Checking tire pressure	80
11.22	Removing the seat	50	13.7	Checking the spoke tension	80
11.23	Mounting the seat	50	14	COOLING SYSTEM	82
11.24	Removing the air filter	50	14.1	Cooling system	82
11.25	Installing the air filter	51	14.2	Checking the antifreeze and coolant level	82
11.26	Cleaning the air filter and air filter box	51	14.3	Checking the coolant level	83
11.27	Removing the main silencer	52	14.4	Draining the coolant	83
11.28	Installing the main silencer	52	14.5	Refilling with coolant	84
11.29	Changing the glass fiber yarn filling of the main silencer	53	14.6	Changing the coolant	85
11.30	Checking the chain for dirt	53	15	TUNING THE ENGINE	87
11.31	Cleaning the chain	54	15.1	Checking the play in the throttle cable	87
11.32	Checking the chain tension	54	15.2	Adjusting the play in the throttle cable	87
11.33	Adjusting the chain tension	55	15.3	Carburettor – idle speed	88
11.34	Checking the chain, rear sprocket, engine sprocket, and chain guide	56	15.4	Carburetor – adjusting the idle speed	88
11.35	Checking the frame	58	15.5	Emptying the carburetor float chamber	89
11.36	Checking the link fork	58	16	SERVICE WORK ON THE ENGINE	91
11.37	Checking the throttle cable routing	58	16.1	Checking the gear oil level	91
11.38	Checking the rubber grip	59	16.2	Changing the gear oil	91
11.39	Additionally securing the rubber grip	59	16.3	Adding the gear oil	92
11.40	Adjusting the basic position of the clutch lever	59	17	CLEANING, CARE	94
11.41	Checking the fluid level of the hydraulic clutch	60	17.1	Cleaning the motorcycle	94
11.42	Correcting the fluid level of the hydraulic clutch	60	18	STORAGE	96
11.43	Changing the hydraulic clutch fluid	61	18.1	Storage	96
12	BRAKE SYSTEM	63	18.2	Preparing for use after storage	97
12.1	Checking the free travel of the hand brake lever	63	19	TROUBLESHOOTING	98
12.2	Adjusting the basic position of the hand brake lever	63	20	TECHNICAL SPECIFICATIONS	100
12.3	Checking the brake discs	63	20.1	Engine	100
12.4	Checking the front brake fluid level	64	20.2	Engine tightening torques	100
12.5	Adding front brake fluid	64	20.3	Carburetor	102
12.6	Checking that the brake linings of the front brake are secured	66	20.3.1	Carburetor tuning	102
12.7	Changing the front brake linings	66	20.4	Capacities	103
12.8	Checking the free travel of the foot brake lever	69	20.4.1	Gear oil	103
12.9	Adjusting the free travel of the foot brake lever	69	20.4.2	Coolant	103
12.10	Adjusting the basic position of the foot brake lever	70	20.4.3	Fuel	103
12.11	Checking the rear brake fluid level	71	20.5	Fork	103
12.12	Adding rear brake fluid	71	20.6	Shock absorber	103
12.13	Checking that the brake linings of the rear brake are secured	73	20.7	Chassis	104
12.14	Changing the rear brake linings	73	20.8	Tires	105
			20.9	Chassis tightening torques	105
			21	SUBSTANCES	107
			22	AUXILIARY SUBSTANCES	109

# TABLE OF CONTENTS

23	STANDARDS .....	111
24	LIST OF ABBREVIATIONS.....	112
	INDEX .....	113

## 1.1 Symbols used

The meaning of specific symbols is described below.



Indicates an expected reaction (e.g., of a work step or a function).



Indicates an unexpected reaction (e.g., of a work step or a function).



Indicates work that requires expert knowledge and technical understanding. In the interest of the safety of your child, have these jobs performed in an authorized GASGAS Motorcycles workshop. Your motorcycle will be cared for there to the highest degree by specially trained experts using the special tools required.



Indicates a page reference (more information is provided on the specified page).



Indicates information with more details or tips.



Indicates the result of a testing step.



Indicates the end of an activity, including potential reworking.



Indicates a voltage measurement.



Indicates a current measurement.

## 1.2 Formats used

The typographical formats used in this document are explained below.

<b>Proprietary name</b>	Indicates a proprietary name.
<b>Name®</b>	Indicates a protected name.
<b>Brand™</b>	Indicates a brand available on the open market.
<b><u>Underlined terms</u></b>	Refer to technical details of the vehicle or indicate technical terms, which are explained in the glossary.

### 2.1 Use definition – intended use

This vehicle has been designed and built to withstand the normal stresses and strains of racing. This vehicle complies with the currently valid regulations and categories of the top international motorsports organizations.



#### Info

Only operate this vehicle in closed-off areas remote from public road traffic.

### 2.2 Misuse

The vehicle must only be used as intended.

Dangers can arise for people, property and the environment through use not as intended.

Any use of the vehicle beyond the intended and defined use constitutes misuse.

Misuse also includes the use of operating and auxiliary fluids which do not meet the required specification for the respective use.

### 2.3 Safety advice

A number of safety instructions need to be followed to operate the product described safely. Therefore read this instruction and all further instructions included carefully. The safety instructions are highlighted in the text and are referred to at the relevant passages.



#### Info

Various information and warning labels are attached in prominent locations on the product described. Do not remove any information or warning labels. If they are missing, you or others may not recognize dangers and may therefore be injured.

### 2.4 Degrees of risk and symbols



#### Danger

Identifies a danger that will immediately and invariably lead to fatal or serious permanent injury if the appropriate measures are not taken.



#### Warning

Identifies a danger that is likely to lead to fatal or serious injury if the appropriate measures are not taken.



#### Caution

Identifies a danger that may lead to minor injuries if the appropriate measures are not taken.

#### Note

Identifies a danger that will lead to considerable machine and material damage if the appropriate measures are not taken.



#### Note

Indicates a danger that will lead to environmental damage if the appropriate measures are not taken.

### 2.5 Tampering warning

Tampering with the noise control system is prohibited. Federal law prohibits the following acts or the causing thereof:



- 1 The removal or rendering inoperative by any person other than for purposes of servicing, repair, or replacement, of any device or element of design incorporated into any new vehicle for the purpose of noise control prior to its sale or delivery to the ultimate purchaser or while it is in use, or
- 2 the use of the vehicle after such device or element of design has been removed or rendered inoperative by any person.

Among those acts presumed to constitute tampering are the acts listed below:

- 1 Removal or puncturing of the main silencers, baffles, header pipes or any other components which conduct exhaust gases.
- 2 Removal or puncturing of parts of the intake system.
- 3 Lack of proper maintenance.
- 4 Replacing moving parts of the vehicle, or parts of the exhaust system or intake system, with parts other than those specified by the manufacturer.

## 2.6 Safe operation



### Danger

**Danger of accidents** A rider who is not fit to ride poses a danger to him or herself and others.

- Do not operate the vehicle if you are not fit to ride due to alcohol, drugs or medication.
- Do not operate the vehicle if you are physically or mentally impaired.



### Danger

**Danger of poisoning** Exhaust gases are toxic and inhaling them may result in unconsciousness and death.

- Always make sure there is sufficient ventilation when running the engine.
- Use effective exhaust extraction when starting or running the engine in an enclosed space.



### Warning

**Danger of burns** Some vehicle components become hot when the vehicle is operated.

- Do not touch any parts such as the exhaust system, radiator, engine, damper, or brake system before the vehicle parts have cooled down.
- Let the vehicle parts cool down before you perform any work on the vehicle.

Only operate the vehicle when it is in perfect technical condition, in accordance with its intended use, and in a safe and environmentally compatible manner.

The vehicle should only be used by trained persons.

Have malfunctions that impair safety immediately eliminated by an authorized GASGAS Motorcycles workshop.

Adhere to the information and warning labels on the vehicle.

## 2.7 Protective clothing



### Warning

**Risk of injury** Missing or poor protective clothing presents an increased safety risk.

- Ensure your child wears appropriate protective clothing such as helmet, boots, gloves as well as trousers and a jacket with protectors on all rides.
- Always use protective clothing for your child that is in good condition and meets the legal requirements.
- When you ride a motorcycle, set an example for your child and wear suitable protective clothing.

In the interest of your own safety, GASGAS recommends that you only operate the vehicle while wearing suitable protective clothing.

### 2.8 Work rules

Unless specified otherwise, the ignition must be turned off during all work (models with ignition lock, models with transponder key) or the motor must be at a standstill (models without ignition lock or transponder key).

Special tools are necessary for certain tasks. If these special tools are not included in the scope of supply of the vehicle, the special tools can be ordered using the specified article number. Example: bearing puller (15112017000)

Unless otherwise noted, normal conditions apply to all tasks and descriptions.

Ambient temperature	20 °C (68 °F)
Ambient air pressure	1,013 mbar (14.69 psi)
Relative air humidity	60 ± 5 %

During assembly, use new parts to replace parts which cannot be reused (e.g. self-locking screws and nuts, expansion screws, seals, sealing rings, O-rings, pins, and lock washers).

In the case of certain screw connections, a thread locker (e.g., **Loctite**®) is required. Observe the manufacturer's instructions.

If a thread locker (e.g. **Precote**®) has already been applied to a new part, do not apply any additional thread locker.

After disassembly, clean the parts that are to be reused and check them for damage and wear. Change damaged or worn parts.

Ensure that the work area is clean and clean components before disassembly if necessary. Penetrating dirt can lead to increased wear and consequential damage.

After completing a repair or service work, check the operating safety of the vehicle.

### 2.9 Environment

If you use your motorcycle responsibly, you can ensure that problems and conflicts do not occur. To protect the future of the motorcycle sport, make sure that you use your motorcycle legally, be environmentally aware, and respect the rights of others.

When disposing of used oil, other operating and auxiliary fluids, and used components, comply with the laws and regulations of the respective country.

Because motorcycles are not subject to the EU regulations governing the disposal of used vehicles, there are no legal regulations that pertain to the disposal of an end-of-life motorcycle. Your authorized GASGAS Motorcycles dealer will be glad to advise you.

### 2.10 Owner's Manual

It is important that you read this Owner's Manual carefully and completely before your child makes his or her first trip. The Owner's Manual contains useful information and many tips for you and your child on how to operate, handle, and service your motorcycle. This is the only way for you to find out how to ideally tune the vehicle and how to protect your child from injury.

Keep the Owner's Manual in an accessible place to enable you to refer to it as needed.

If you would like to know more about the vehicle or have questions on the material you read, please contact an authorized GASGAS Motorcycles dealer.

The Owner's Manual is an important component of the vehicle and must be handed over to the new owner if the vehicle is sold.

The Owner's Manual is also available for download from your authorized GASGAS Motorcycles dealer and on the GASGAS Motorcycles website.

International GASGAS website: <http://www.gasgas.com>

**3.1 Manufacturer warranty, implied warranty**

The work prescribed in the service schedule must be carried out in an authorized GASGAS Motorcycles workshop only and confirmed in the electronic proof of service, as otherwise no warranty claims will be recognized. Damage or secondary damage caused by tampering with and/or conversions on the vehicle are not covered by the manufacturer warranty.

**3.2 Fuel, auxiliary substances**



**Note**

**Environmental hazard** Improper handling of fuel is a danger to the environment.

- Do not allow fuel to enter the groundwater, the soil, or the sewage system.

Use fuels and auxiliary substances in accordance with the Owner's Manual and specification.

**3.3 Spare parts, accessories**

For the safety of your child, only use spare parts and accessory products that are approved and/or recommended by GASGAS and have them installed by an authorized GASGAS Motorcycles workshop. GASGAS accepts no liability for other products and any resulting damage or loss.

Certain spare parts and accessory products are specified in parentheses in the descriptions. Your authorized GASGAS Motorcycles dealer will be glad to advise you.

The latest news **GASGAS Technical Accessories** on your vehicle can be found on the GASGAS Motorcycles website. Int'l GASGAS website: <http://www.gasgas.com>

**3.4 Service**

A prerequisite for perfect operation and prevention of premature wear is that the service, care, and tuning work on the engine and chassis is properly carried out as described in the Owner's Manual. An incorrect suspension setting can lead to damage and breakage of chassis components.

Use of the vehicle under difficult conditions, such as on sand or on wet, dusty and muddy surfaces, can result in significantly increased wear of components, such as the drive train, brake system, air filter or suspension components. For this reason, it may be necessary to inspect or replace parts before the next scheduled service.

It is imperative that you adhere to the stipulated run-in times and service intervals. If you observe these exactly, you will ensure a much longer service life for your motorcycle.

The relevant mileage or time interval is whichever occurs first.

**3.5 Figures**

The figures contained in the manual may depict special equipment.

In the interest of clarity, some components may be shown disassembled or may not be shown at all. It is not always necessary to disassemble the component to perform the activity in question. Please follow the instructions in the text.

**3.6 Customer service**

Your authorized GASGAS Motorcycles dealer will be happy to answer any questions you may have regarding your vehicle and GASGAS.

A list of authorized GASGAS Motorcycles dealers can be found on the GASGAS Motorcycles website.

Int'l GASGAS website: <http://www.gasgas.com>

## 4 VIEW OF VEHICLE

### 4.1 View of vehicle, front left (example)



- ❶ Hand brake lever (📖 p. 14)
- ❷ Valve for fork airpump
- ❸ Clutch lever (📖 p. 14)
- ❹ Quick release for seat lock
- ❺ Shock absorber rebound adjuster
- ❻ Choke (📖 p. 16)
- ❼ Shift lever (📖 p. 16)
- ❽ Fuel tap (📖 p. 16)

## 4.2 View of vehicle, rear right (example)



F03039-10

- ❶ Fuel tank filler cap
- ❷ Stop button (📖 p. 14)
- ❸ Fork rebound adjustment
- ❹ Vehicle identification number (📖 p. 12)
- ❺ Throttle grip (📖 p. 14)
- ❻ Kick starter lever (📖 p. 17)
- ❼ Foot brake lever (📖 p. 17)
- ❽ Shock absorber compression adjuster
- ❾ Level viewer for brake fluid, rear

## 5 SERIAL NUMBERS

### 5.1 Vehicle identification number

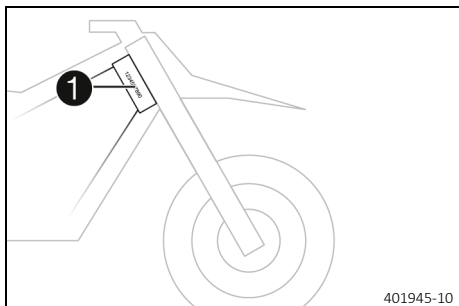

The vehicle identification number **1** is stamped on the right side of the steering head.

### 5.2 Type label

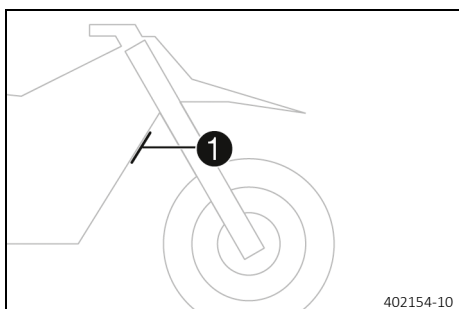

The type label **1** is located on the front frame tube.

### 5.3 Engine number

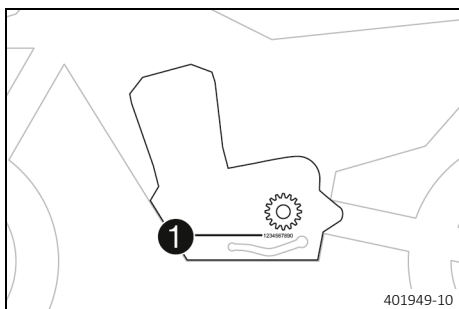

The engine number **1** is located on the left side of the engine under the engine sprocket.

### 5.4 Fork article number

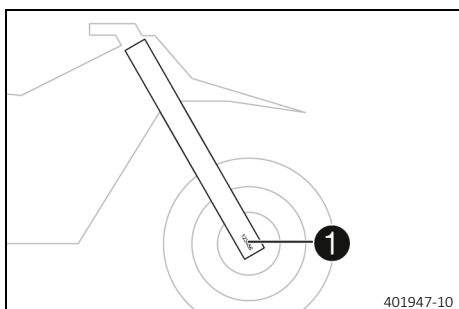

The fork article number **1** is stamped on the outside of the axle clamp.

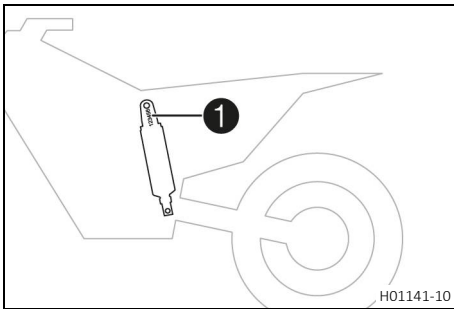
**5.5 Shock absorber article number**

The shock absorber article number **1** is stamped on the top of the shock absorber above the adjusting ring towards the left-hand side.

## 6.1 Clutch lever

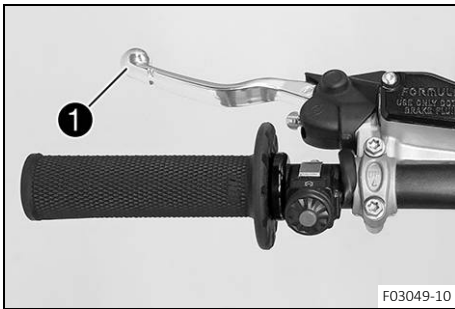

The clutch lever **1** is fitted on the left side of the handlebar. The clutch is hydraulically operated and self-adjusting.

## 6.2 Hand brake lever

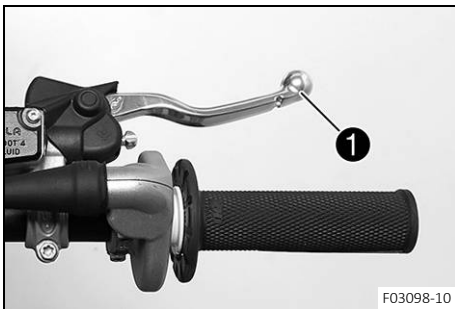

Hand brake lever **1** is fitted on the right side of the handlebar. The hand brake lever is used to activate the front brake.

## 6.3 Throttle grip



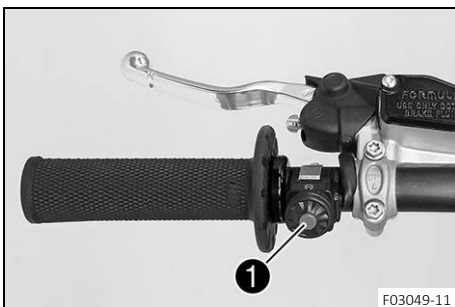

Throttle grip **1** is fitted on the right side of the handlebar.

## 6.4 Stop button



The stop button **1** is fitted on the left side of the handlebar.

### Possible states

- The stop button  is in the basic position – In this position, the ignition circuit is closed and the engine can be started.
- Stop button  pressed – In this position, the ignition circuit is interrupted, a running engine stops, and a non-running engine will not start.



6.5 Opening the fuel tank filler cap



**Danger**

**Fire hazard** Fuel is highly flammable.

The fuel in the fuel tank expands when warm and can escape if overfilled.

- Do not fuel the vehicle in the vicinity of open flames or lit cigarettes.
- Switch off the engine for refueling.
- Make sure that no fuel is spilled; particularly not on hot parts of the vehicle.
- If any fuel is spilled, wipe it off immediately.
- Observe the specifications for refueling.



**Warning**

**Danger of poisoning** Fuel is harmful to health.

- Avoid skin, eye and clothing contact with fuel.
- Immediately consult a doctor if you swallow fuel.
- Do not inhale fuel vapors.
- Rinse the affected area immediately with plenty of water in the event of contact with the skin.
- Rinse the eyes thoroughly with water, and consult a doctor in case of fuel contact with the eyes.
- Change your clothing if fuel spills on them.
- Keep fuels correctly in a suitable canister, and out of the reach of children.



**Note**

**Environmental hazard** Improper handling of fuel is a danger to the environment.

- Do not allow fuel to enter the groundwater, the soil, or the sewage system.

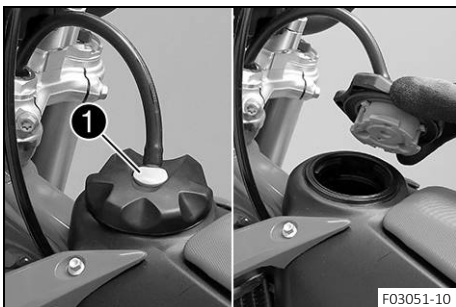

- Press release button ①, turn the fuel tank filler cap counterclockwise, and lift it off.

6.6 Closing the fuel tank filler cap

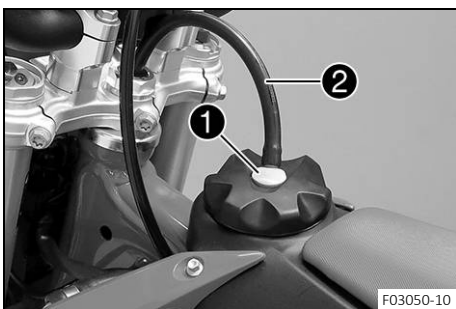

- Mount the fuel tank filler cap and turn it clockwise until release button ① engages.



**Info**

Route fuel tank breather hose ② without kinks.

## 6.7 Fuel tap



Fuel tap **1** is on the left of the fuel tank.

### Possible states

- Fuel tap is closed – The knurled screw is turned all the way clockwise. Fuel cannot flow out of the fuel tank.
- Fuel tap is open – The knurled screw is turned all the way counter-clockwise. Fuel can flow out of the fuel tank.

## 6.8 Choke



Choke lever **1** is fitted on the left side of the carburetor.

Activating the choke function frees a drill hole in the carburetor through which the engine can draw extra fuel. This results in a richer fuel-air mixture, which is needed for a cold start.

### **i** Info

If the engine is warm, the choke function must be deactivated.

### Possible states

- Choke function activated – The choke lever is pushed down all the way to the stop.
- Choke function deactivated – The choke lever is pushed up all the way to the stop.

## 6.9 Shift lever

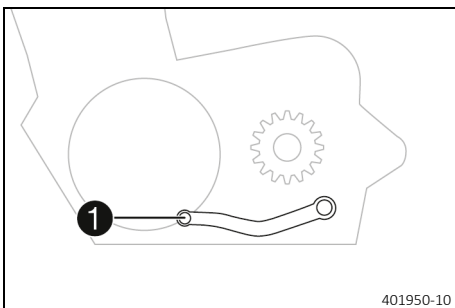

Shift lever **1** is mounted on the left of the engine.

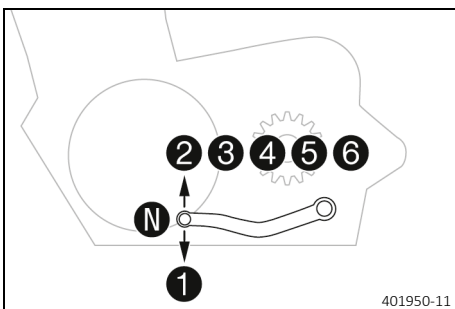

The gear positions can be seen in the figure.

The neutral or idle position **N** is between the first and second gear.

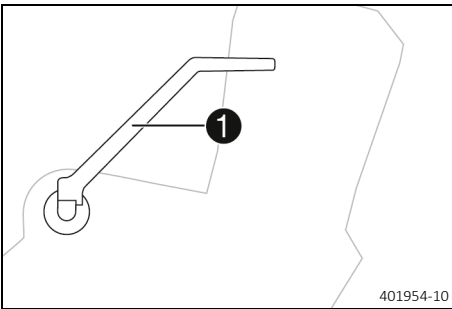
**6.10 Kick starter lever**

Kick starter lever ① is fitted on the right side of the engine.  
The kick starter lever can be swiveled.

**Info**

Before riding, swing the kick starter lever inwards towards the engine.

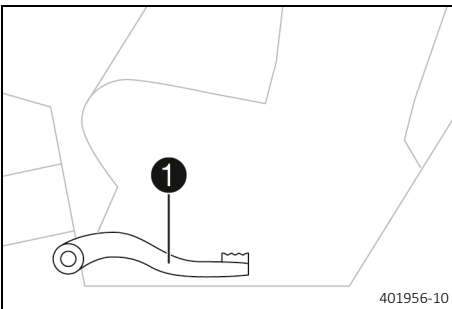
**6.11 Foot brake lever**

Foot brake lever ① is located in front of the right footrest.  
The rear brake is engaged with the foot brake lever.

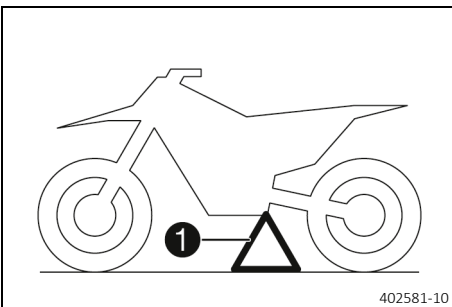
**6.12 Plug-in stand**

The fixture for plug-in stand ① is located on the frame on the left side of the vehicle.  
The plug-in stand is used to park the motorcycle.

**Info**

Remove the plug-in stand before riding.

### 7.1 Advice on preparing for first use



#### Warning

**Danger of accidents** A lack of physical and mental readiness on the part of the child poses a major risk.

Children often underestimate or fail to recognize dangerous situations.

- Your child must already be able to ride a bicycle.
- Your child must be able to put the vehicle upright independently after a fall.
- Your child must understand that regulations and instructions from you or from other guardians must be followed.
- Make it clear to your child that they should not, under any circumstances, operate the vehicle without supervision.
- Make it clear to your child that he or she may only drive at speeds corresponding to the child's riding abilities and the road conditions.
- Do not ask too much of your child.  
Make sure that their stamina, riding technique and motivation are at the necessary levels.
- Only let your child ride on the vehicle if they are physically and mentally ready.



#### Warning

**Risk of injury** Missing or poor protective clothing presents an increased safety risk.

- Ensure your child wears appropriate protective clothing such as helmet, boots, gloves as well as trousers and a jacket with protectors on all rides.
- Always use protective clothing for your child that is in good condition and meets the legal requirements.
- When you ride a motorcycle, set an example for your child and wear suitable protective clothing.



#### Warning

**Danger of crashing** Different tire tread patterns on the front and rear wheel impair the handling characteristic.

Different tire tread patterns can make the vehicle significantly more difficult to control.

- Make sure that only tires with a similar tire tread pattern are fitted to the front and rear wheel.



#### Warning

**Danger of accidents** An unadapted riding style constitutes a major risk.

- Ensure that your child adapts the riding speed to the road conditions and to his or her riding abilities.



#### Warning

**Danger of accidents** The vehicle is not designed to carry passengers.

- Make it clear to your child that he or she must not carry a passenger.



#### Warning

**Danger of accidents** The brake system fails in the event of overheating.

If the foot brake lever is not released, the brake linings drag continuously.

- Ensure that your child raises his or her foot from the foot brake lever if he or she does not want to brake.



#### Warning

**Danger of accidents** The suspension components will become damaged or destroyed if overloaded.

- Do not exceed the maximum permissible weight of the rider.



#### Warning

**Risk of injury** People who act without authorization may not be familiar with the vehicle.

- Do not leave the vehicle unattended if the engine is running.
- Protect the vehicle against access by unauthorized persons.

**i Info** When using the motorcycle, remember that others may be disturbed by excessive noise.

- Ensure that the pre-sale inspection work has been carried out by an authorized GASGAS Motorcycles workshop.
  - ✓ You will receive a delivery certificate when the vehicle is handed over.
- Read through the entire Owner's Manual together with your child before riding for the first time.

**i Info** Pay special attention to the safety instructions and to the risk of injury. Explain to your child the techniques of riding and falling, e.g., how shifting weight can influence handling characteristics.

- Familiarize your child with the controls.
- Adjust the basic position of the clutch lever. (📖 p. 59)
- Adjust the basic position of the hand brake lever. (📖 p. 63)
- Adjust the basic position of the foot brake lever. 🦶 (📖 p. 70)
- Before using the vehicle for the first time, ensure that the basic settings of the chassis are suitable for the weight of your child.
- Allow your child to become accustomed to the handling of the motorcycle on suitable terrain, preferably on a large, open meadow.

**i Info** To give your child a feeling for the brake system, you should push your child at first. Do not start the engine until your child is able to apply the necessary front brake pressure. Initially, let your child ride to another person who can help your child stop and turn.

- Erect obstacles for your child to navigate around so that your child becomes accustomed to handling the vehicle.
- Your child should also try to ride as slowly as possible and in a standing position to get a better feeling for the motorcycle.
- Your child should not ride on terrain that exceeds your child's capabilities and experience.
- Your child should hold the handlebar firmly with both hands and keep his or her feet on the footrests when riding.
- Make sure the maximum permissible weight of the rider is not exceeded.

Guideline

Maximum rider weight	50 kg (110 lb.)
----------------------	-----------------

- Check the spoke tension. (📖 p. 80)

**i Info** The spoke tension must be checked after half an hour of operation.

- Run the engine in. (📖 p. 19)

**7.2 Running in the engine**

- During the running-in time, do not exceed the specified engine load.

Guideline

Maximum engine performance	
During the first 3 operating hours	< 70 %
During the first 5 operating hours	< 100 %

**i Info** The use of a service hour counter is recommended in order to be able to check the mileage at any time.

- Avoid fully opening the throttle.



## 8.1 Checks and maintenance measures when preparing for use

### **i** Info

Before every trip, check the condition of the vehicle and ensure that it is safe to operate. The vehicle must be in perfect technical condition when it is being operated.

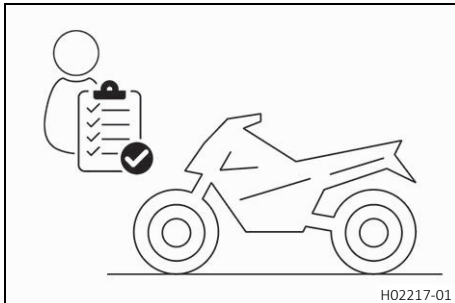

- Check the gear oil level. (📖 p. 91)
- Check the front brake fluid level. (📖 p. 64)
- Check the rear brake fluid level. (📖 p. 71)
- Check that the brake linings of the front brake are secured. (📖 p. 66)
- Check that the brake linings of the rear brake are secured. (📖 p. 73)
- Check that the brake system is functioning properly.
- Check the coolant level. (📖 p. 83)
- Check the chain for dirt. (📖 p. 53)
- Check the chain, rear sprocket, engine sprocket, and chain guide. (📖 p. 56)
- Check the chain tension. (📖 p. 54)
- Check the tire condition. (📖 p. 79)
- Check tire pressure. (📖 p. 80)
- Check the spoke tension. (📖 p. 80)

### **i** Info

The spoke tension must be checked regularly as incorrect spoke tension will strongly impair riding safety.

- Clean the dust boots of the fork legs. (📖 p. 38)
- Bleed the fork legs. (📖 p. 37)
- Check the air filter.
- Check the settings of all controls and ensure that they can be operated smoothly.
- Check all screws, nuts, and hose clamps regularly for tightness.
- Check the fuel level.



## 8.2 Starting the vehicle



### **Danger**

**Danger of poisoning** Exhaust gases are toxic and inhaling them may result in unconsciousness and death.

- Always make sure there is sufficient ventilation when running the engine.
- Use effective exhaust extraction when starting or running the engine in an enclosed space.

### **Note**

**Engine failure** High rpm with a cold engine negatively impacts the lifespan of the engine.

- Ensure that the engine is always warmed up at low engine speeds.

### **i** Info

If the motorcycle is unwilling to start, the cause can be old fuel in the float chamber. The flammable elements of the fuel evaporate after a long time of standing.

If the float chamber is filled with fresh fuel, the engine starts immediately.

### The motorcycle has been out of use for more than 1 week

- Empty the carburetor float chamber.  (p. 89)
- Turn the knurled screw on the fuel tap all the way counterclockwise.
  - ✓ Fuel can flow from the fuel tank to the carburetor.
- Remove the motorcycle from the stand.
- Shift the transmission into neutral.

### The engine is cold

- Push down the choke lever all the way to the stop.
- Press the kick starter lever robustly through its full range.



#### Info

Do not open the throttle.

## 8.3 Starting off



#### Info

The plug-in stand must be removed prior to riding.

- Pull the clutch lever, engage 1st gear, release the clutch lever slowly and simultaneously open the throttle carefully.

## 8.4 Shifting, riding



#### Warning

**Danger of accidents** If you change down at high engine speed, the rear wheel blocks and the engine races.

- Make it clear to your child that he or she must not change into a low gear at high engine speed.



#### Info

If unusual noises occur while riding, stop immediately, switch off the engine, and contact an authorized GASGAS Motorcycles workshop.

First-gear is used for starting off and for steep inclines.

- When conditions allow (incline, road situation, etc.), your child can shift into a higher gear. To do so, release the throttle while simultaneously pulling the clutch lever, shift into the next gear, release the clutch lever and open the throttle.
- If the choke function has been activated, deactivate it after the engine has warmed up.
- After reaching maximum speed by fully opening the throttle grip, turn the throttle back so it is  $\frac{3}{4}$  open. This will barely reduce the speed, but fuel consumption will be considerably lower.
- Your child should always open the throttle only as much as the engine can handle – abruptly opening the throttle increases fuel consumption.
- To shift down, apply the brakes and close the throttle at the same time.
- Pull the clutch lever and shift into a lower gear, release the clutch lever slowly, and either open the throttle or shift again.
- Your child should switch off the engine if prolonged operation at idle speed or while stationary is imminent.

Guideline

$\geq 2$  min

- Your child should avoid frequent or extended slipping of the clutch. This heats the engine oil, the engine, and the cooling system.
- Insist that your child ride with a low speed instead of with a high speed and a slipping clutch.



## 8.5 Applying the brakes



### Warning

**Danger of accidents** Excessively forceful application of the brakes blocks the wheels.

- Explain to your child that he or she must adapt the braking to the traffic situation and the road conditions.



### Warning

**Danger of accidents** A spongy pressure point on the front or rear brake reduces braking efficiency.

- Check the brake system and do not allow your child to continue riding until the problem is eliminated. (Your authorized GASGAS Motorcycles workshop will be glad to help.)



### Warning

**Danger of accidents** Moisture and dirt impair the brake system.

- Explain to your child that he or she must brake carefully several times to dry out and remove dirt from the brake linings and the brake discs.

- On sandy, wet, or slippery surfaces, use the rear brake.
- Always finish braking before you go into a bend. Your child should change down to a lower gear appropriate to the road speed.
- Insist that your child take advantage of the braking action of the engine when riding on long downhill. To do so, shift back one or two gears, but do not overrev the engine. Your child will need to apply the brakes far less often and the brake system will not overheat.



## 8.6 Stopping, parking



### Warning

**Risk of injury** People who act without authorization may not be familiar with the vehicle.

- Do not leave the vehicle unattended if the engine is running.
- Protect the vehicle against access by unauthorized persons.



### Warning

**Danger of burns** Some vehicle components become hot when the vehicle is operated.

- Do not touch any parts such as the exhaust system, radiator, engine, damper, or brake system before the vehicle parts have cooled down.
- Let the vehicle parts cool down before you perform any work on the vehicle.

### Note

**Material damage** The vehicle may be damaged by incorrect procedure when parking.

Significant damage may be caused if the vehicle rolls away or falls over.

The components for parking the vehicle are designed only for the weight of the vehicle.

- Park the vehicle on a firm and level surface.
- Ensure that nobody sits on the vehicle when the vehicle is parked on a stand.

### Note

**Fire hazard** Hot vehicle components pose a fire hazard and explosion risk.

- Do not park the vehicle near to materials which are highly flammable or explosive.
- Allow the vehicle to cool down before covering it.

- Apply the brakes on the motorcycle.
- Shift the transmission into neutral.
- Press and hold the stop button  while the engine is idling until the engine stops.
- Turn the knurled screw on the fuel tap all the way clockwise.

- Park the motorcycle on firm ground.

## 8.7 Transporting

### Note

**Material damage** The vehicle may be damaged by incorrect procedure when parking.

Significant damage may be caused if the vehicle rolls away or falls over.

The components for parking the vehicle are designed only for the weight of the vehicle.

- Park the vehicle on a firm and level surface.
- Ensure that nobody sits on the vehicle when the vehicle is parked on a stand.

### Note

**Fire hazard** Hot vehicle components pose a fire hazard and explosion risk.

- Do not park the vehicle near to materials which are highly flammable or explosive.
- Allow the vehicle to cool down before covering it.

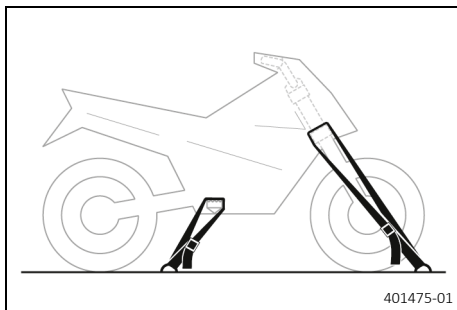

- Switch off the engine.
- Use tension belts or other suitable devices to secure the motorcycle against falling over or rolling away.

## 8.8 Refueling



### Danger

**Fire hazard** Fuel is highly flammable.

The fuel in the fuel tank expands when warm and can escape if overfilled.

- Do not fuel the vehicle in the vicinity of open flames or lit cigarettes.
- Switch off the engine for refueling.
- Make sure that no fuel is spilled; particularly not on hot parts of the vehicle.
- If any fuel is spilled, wipe it off immediately.
- Observe the specifications for refueling.



### Warning

**Danger of poisoning** Fuel is harmful to health.

- Avoid skin, eye and clothing contact with fuel.
- Immediately consult a doctor if you swallow fuel.
- Do not inhale fuel vapors.
- Rinse the affected area immediately with plenty of water in the event of contact with the skin.
- Rinse the eyes thoroughly with water, and consult a doctor in case of fuel contact with the eyes.
- Change your clothing if fuel spills on them.



### Note

**Environmental hazard** Improper handling of fuel is a danger to the environment.

- Do not allow fuel to enter the groundwater, the soil, or the sewage system.

- Switch off the engine.
- Open the fuel tank filler cap. (📖 p. 15)
- Fill the fuel tank with fuel up to a maximum of level **A**.

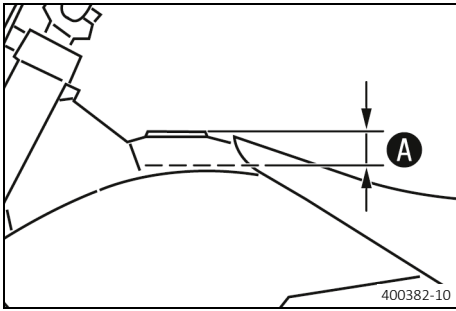

Guideline

Dimension <b>A</b>	35 mm (1.38 in)	
Fuel tank capacity, approx.	3.5 l (3.7 qt.)	Super unleaded (95 octane) mixed with 2-stroke engine oil (1:60) (📖 p. 108)

- Close the fuel tank filler cap. (📖 p. 15)



# 9 SERVICE SCHEDULE

## 9.1 Additional information

Any further work that results from the compulsory work or from the recommended work must be ordered separately and invoiced separately.

Different service intervals may apply in your country, depending on the local operating conditions.

Individual service intervals and scopes may change in the course of technical developments. The most up-to-date service schedule can always be found on GASGAS Motorcycles Dealer.net. Your authorized GASGAS Motorcycles dealer will be glad to advise you.

The use of a service hour counter is recommended in order to be able to check the mileage at any time.

Service hour counter (A54012920000)

## 9.2 Required work

	Every 80 operating hours	Every 40 operating hours	Every 20 operating hours	After 10 operating hours
Check that the brake linings of the front brake are secured. (📖 p. 66)	○	●	●	●
Check that the brake linings of the rear brake are secured. (📖 p. 73)	○	●	●	●
Check the brake discs. (📖 p. 63)	○	●	●	●
Check the brake lines for damage and leakage.	○	●	●	●
Change the foot brake cylinder sealing cup. 🛠️		●	●	●
Check the rear brake fluid level. (📖 p. 71)	○	●	●	●
Check the free travel of the foot brake lever. (📖 p. 69)	○	●	●	●
Check the frame. 🛠️ (📖 p. 58)		●	●	●
Check the link fork. 🛠️ (📖 p. 58)		●	●	●
Checking the fork bearing for play. 🛠️		●	●	●
Check the shock absorber heim joint for play. 🛠️		●	●	●
Check the tire condition. (📖 p. 79)	○	●	●	●
Check tire pressure. (📖 p. 80)	○	●	●	●
Check the wheel bearing for play. 🛠️		●	●	●
Check the wheel hubs. 🛠️		●	●	●
Check the rim run-out. 🛠️	○	●	●	●
Check the spoke tension. (📖 p. 80)	○	●	●	●
Check the chain, rear sprocket, engine sprocket, and chain guide. (📖 p. 56)	○	●	●	●
Check the chain tension. (📖 p. 54)	○	●	●	●
Grease all moving parts (e.g., hand lever, chain, ...) and check for smooth operation. 🛠️	○	●	●	●
Check the fluid level of the hydraulic clutch. (📖 p. 60)	○	●	●	●
Check the front brake fluid level. (📖 p. 64)	○	●	●	●
Check the free travel of the hand brake lever. (📖 p. 63)	○	●	●	●
Check the steering head bearing play. (📖 p. 44)	○	●	●	●
Change the spark plug and spark plug connector. 🛠️		●	●	●
Change the gear oil. 🛠️ (📖 p. 91)	○		●	●
Check the gear oil level. (📖 p. 91)		●		
Check the clutch. 🛠️		●	●	●
Check all hoses (e.g. fuel, cooling, bleeder, drainage, etc.) and sleeves for cracking, leaks, and incorrect routing. 🛠️	○	●	●	●
Check the antifreeze and coolant level. (📖 p. 82)	○	●	●	●
Check the cables for damage and routing without sharp bends. 🛠️	○	●	●	●
Check that the throttle cables are undamaged, routed without sharp bends, and set correctly.	○	●	●	●

	Every 80 operating hours			
	Every 40 operating hours			
	Every 20 operating hours			
	After 10 operating hours			
Clean the air filter and air filter box. 🛠️ (📖 p. 51)	○	●	●	●
Change the glass fiber yarn filling of the main silencer. 🛠️ (📖 p. 53)		●	●	●
Service the fork. 🛠️			●	●
Perform the shock absorber service. 🛠️				●
Check the tightness of the easily accessible, safety-relevant screws and nuts. 🛠️	○	●	●	●
Check the idle speed. 🛠️	○	●	●	●
Final check: Check the vehicle for safe operation and take a test ride. 🛠️	○	●	●	●
Make a service entry in <b>GASGAS Motorcycles Dealer.net</b> . 🛠️	○	●	●	●

- One-time interval
- Periodic interval

**9.3 Recommended work**

	every 48 months			
	every 12 months			
	Every 80 operating hours			
	Every 40 operating hours			
	After 20 operating hours / Every 20 operating hours			
	After 10 operating hours			
Change the front brake fluid. 🛠️			●	●
Change the rear brake fluid. 🛠️			●	●
Change the hydraulic clutch fluid. 🛠️ (📖 p. 61)			●	●
Lubricate the steering head bearing. 🛠️ (📖 p. 45)			●	●
Service the fork. 🛠️	○			
Perform the shock absorber service. 🛠️		○		
Check/set the carburetor components. 🛠️			●	●
Change the coolant. 🛠️ (📖 p. 85)				●
Perform minor engine service. Check the cylinder and piston. Check the inlet membrane. Check the exhaust control for functioning and smooth operation.) 🛠️		●	●	●
Perform major engine service including removing and installing the engine. (Change the spring of the exhaust control. Change the piston. Change the connecting rod, conrod bearing and crank pin. Change the crankshaft bearing. Check the transmission and shift mechanism. Change all engine bearings.) 🛠️			●	

- One-time interval
- Periodic interval

## 10.1 Checking the basic chassis setting with rider's weight

### **i** Info

When adjusting the basic chassis setting, first adjust the shock absorber and then the fork.

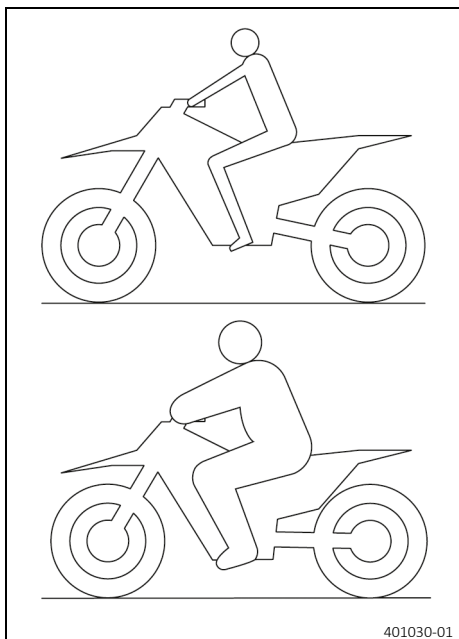

- For optimal motorcycle riding characteristics and to avoid damage to forks, shock absorbers, link fork and frame, the basic settings of the suspension components must match the rider's weight.
- In the delivered condition, this vehicle is adjusted for an average rider's weight (with full protective clothing).

#### Guideline

Standard rider weight	35 ... 45 kg (77 ... 99 lb.)
-----------------------	------------------------------

- If the rider's weight is above or below this range, the basic setting of the suspension components must be adjusted accordingly.
- Small weight differences can be compensated by adjusting the spring preload, but in the case of large weight differences, the springs must be replaced.

## 10.2 Air suspension

Air suspension is used in this fork.

In this system, the suspension is located in the left fork leg and damping in the right fork leg.

As fork springs are no longer required, a significant weight advantage is achieved when compared to conventional forks. The response on slightly uneven surfaces is significantly improved.

In normal driving mode, suspension is provided exclusively by an air cushion. A steel spring is located in the left fork leg as an end stop.

### **i** Info

If the fork is frequently overloaded, then the air pressure in the fork must be increased to avoid damage to the fork and frame.

The air pressure in the fork can be quickly adjusted to the rider's weight, surface conditions and the rider's preference using a fork airpump. The fork does not have to be dismantled. The time consuming mounting of harder or softer fork springs is not required.

If the air chamber loses air due to a damaged seal, the fork will still not sag. In this case the air is retained in the fork. The suspension travel is maintained as far as possible. The damping becomes harder and the riding comfort reduces.

The rebound damping can be adjusted.

The rebound adjustment is located at the upper end of the right fork leg.

**10.3 Compression damping of the shock absorber**

The compression damping of the shock absorber is divided into two ranges: high-speed and low-speed. High-speed and low-speed refer to the compression speed of the rear wheel suspension and not to the vehicle speed. The high-speed compression adjuster has an effect, for example, when landing after a jump: the rear wheel suspension compresses quickly. The low-speed compression adjuster has an effect, for example, when riding over long ground swells: the rear wheel suspension compresses slowly. These two ranges can be adjusted separately, although the transition between high-speed and low-speed is gradual. Thus, modifications in the high-speed range affect the compression damping in the low-speed range and vice versa.

**10.4 Adjusting the low-speed compression damping of the shock absorber**

**Caution**  
**Risk of injury** Parts of the shock absorber will move around if the shock absorber is detached incorrectly. The shock absorber is filled with highly compressed nitrogen.  
 – Please follow the description provided. (Your authorized GASGAS Motorcycles workshop will be glad to help.)

**Info**  
 The effect of the low-speed compression adjuster can be seen in slow to normal compression of the shock absorber.

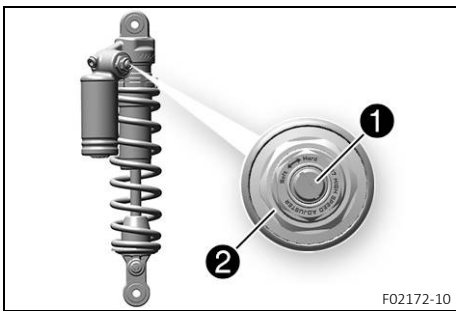

- Turn adjusting screw ① clockwise with a screwdriver as far as the last perceptible click.

**Info**  
 Do not loosen fitting ②!

- Turn counterclockwise by the number of clicks corresponding to the shock absorber type.

Guideline

Low-speed compression damping	
Comfort	18 clicks
Standard	15 clicks
Sport	12 clicks

**Info**  
 Turn clockwise to increase damping; turn counterclockwise to reduce damping.

**10.5 Adjusting the high-speed compression damping of the shock absorber**

**Caution**  
**Risk of injury** Parts of the shock absorber will move around if the shock absorber is detached incorrectly. The shock absorber is filled with highly compressed nitrogen.  
 – Please follow the description provided. (Your authorized GASGAS Motorcycles workshop will be glad to help.)

**Info**  
 The effect of the high-speed compression adjuster can be seen in fast compression of the shock absorber.

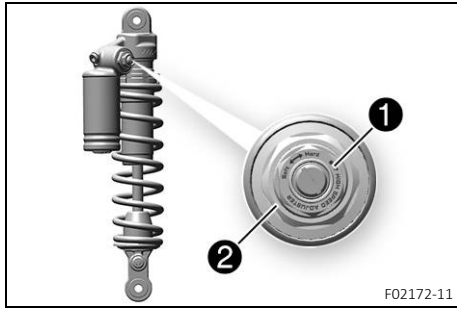

- Turn adjusting screw **1** all the way clockwise with a socket wrench.

**i Info**

Do not loosen fitting **2**!

- Turn counterclockwise by the number of turns corresponding to the shock absorber type.

Guideline

High-speed compression damping	
Comfort	2.5 turns
Standard	2 turns
Sport	1.5 turns

**i Info**

Turn clockwise to increase damping; turn counterclockwise to reduce damping.

## 10.6 Adjusting the rebound damping of the shock absorber



**Caution**

**Risk of injury** Parts of the shock absorber will move around if the shock absorber is detached incorrectly.

The shock absorber is filled with highly compressed nitrogen.

- Please follow the description provided. (Your authorized GASGAS Motorcycles workshop will be glad to help.)

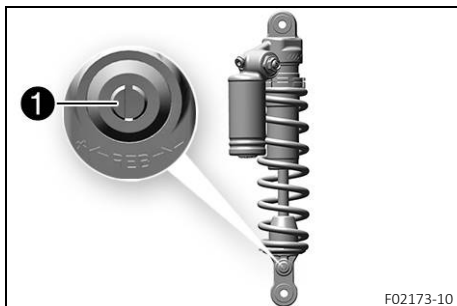

- Turn adjusting screw **1** clockwise up to the last perceptible click.
- Turn counterclockwise by the number of clicks corresponding to the shock absorber type.

Guideline

Rebound damping	
Comfort	18 clicks
Standard	15 clicks
Sport	12 clicks

**i Info**

Turn clockwise to increase the damping; turn counterclockwise to reduce damping when the shock absorber rebounds.

## 10.7 Measuring the dimension of the rear wheel unloaded

**Preparatory work**

- Raise the motorcycle with a lift stand. (📖 p. 37)



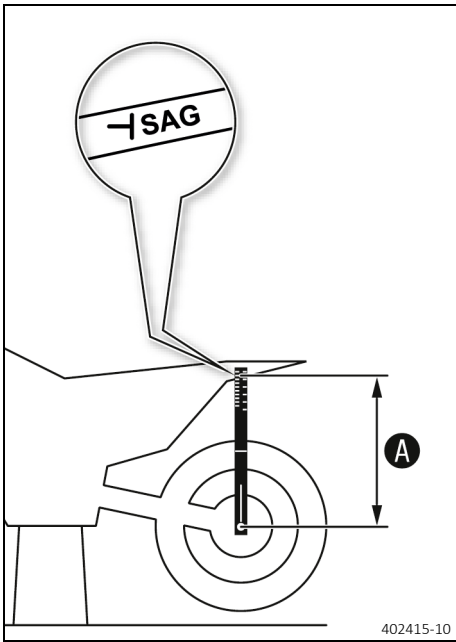

**Main work**

- Position the sag gage in the rear axle and measure the distance to marking **SAG** on the rear fender.

Sag gage (00029090200)
------------------------

- Note the value as dimension **A**.

**Finishing work**

- Remove the motorcycle from the lift stand. (📖 p. 37)

**10.8 Checking the static sag of the shock absorber**

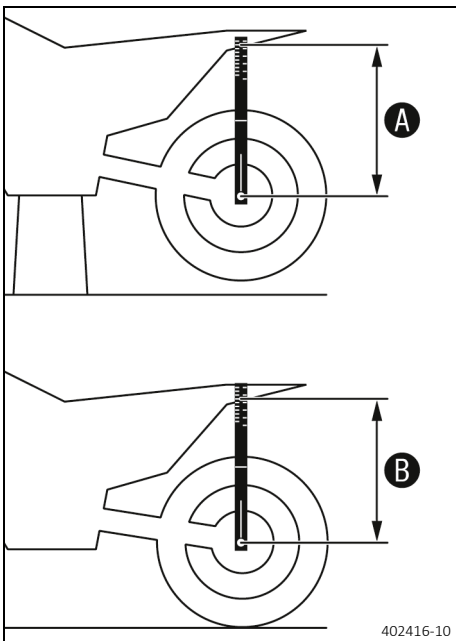

- Measure dimension **A** of rear wheel unloaded. (📖 p. 30)
- Hold the motorcycle upright with aid of an assistant.
- Measure the distance again between the rear axle and marking **SAG** on the rear fender using the sag gage.
- Note the value as dimension **B**.

**i Info**  
The static sag is the difference between measurements **A** and **B**.

- Check the static sag.

Static sag	30 mm (1.18 in)
------------	-----------------

- » If the static sag is less or more than the specified value:
  - Adjust the spring preload of the shock absorber. (🔧 p. 32)

## 10.9 Checking the riding sag of the shock absorber

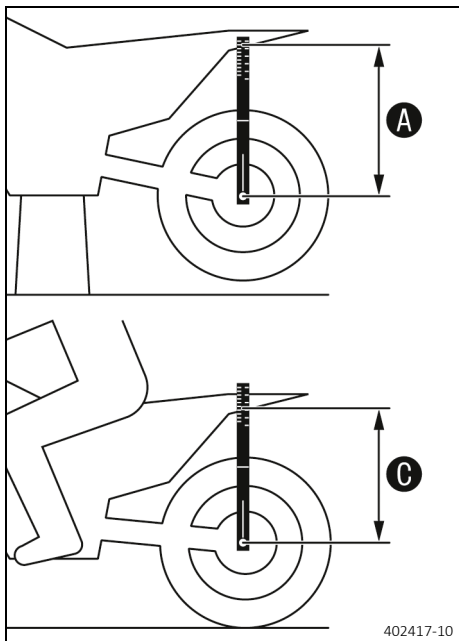

- Measure dimension **A** of rear wheel unloaded. (📖 p. 30)
- With another person holding the motorcycle, the rider, wearing full protective clothing, sits on the seat in a normal sitting position (feet on footrests) and bounces up and down a few times.
  - ✓ The rear wheel suspension levels out.
- Another person again measures the distance between the rear axle and marking **SAG** on the rear fender using the sag gage.
- Note the value as dimension **C**.

### **i** Info

The riding sag is the difference between measurements **A** and **C**.

- Check riding sag.

### Guideline

Rider sag	70 mm (2.76 in)
-----------	-----------------

- » If the riding sag differs from the specified measurement:
  - Adjust the riding sag. (🔧📖 p. 33)

## 10.10 Adjusting the spring preload of the shock absorber 🛠️



### Caution

**Risk of injury** Parts of the shock absorber will move around if the shock absorber is detached incorrectly.

The shock absorber is filled with highly compressed nitrogen.

- Please follow the description provided. (Your authorized GASGAS Motorcycles workshop will be glad to help.)

### Preparatory work

- Raise the motorcycle with a lift stand. (📖 p. 37)
- Remove the shock absorber. (🔧📖 p. 49)
- After removing the shock absorber, clean it thoroughly.

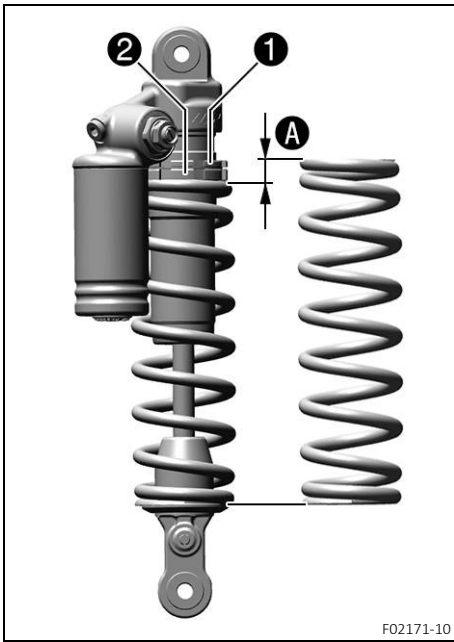

F02171-10

**Main work**

- Measure the full spring length while it is under tension and note down the value.
- Loosen retaining ring ①.
- Turn adjusting ring ② until the spring is no longer under tension.

Combination wrench (50329080000)
Hook wrench (T106S)

**i Info**  
If the spring cannot be fully released, the spring must be removed to accurately measure the spring length.

- Measure the total spring length while the spring is not under tension.
- Tension the spring by turning adjusting ring ② to specified dimension A.

**Guideline**

Spring preload	5 mm (0.2 in)
----------------	---------------

**i Info**  
The spring preload is the difference between the relaxed spring length and the tensioned spring length.  
Depending on the static sag and/or the riding sag, it may be necessary to increase or decrease the spring preload.

- Tighten retaining ring ①.

**Finishing work**

- Install the shock absorber. 🛠️ (📖 p. 49)
- Remove the motorcycle from the lift stand. (📖 p. 37)

**10.11 Adjusting the riding sag 🛠️**

**Preparatory work**

- Raise the motorcycle with a lift stand. (📖 p. 37)
- Remove the shock absorber. 🛠️ (📖 p. 49)
- After removing the shock absorber, clean it thoroughly.

**Main work**

- Choose and mount a suitable spring.

**Guideline**

Spring rate	
Weight of rider: 35 kg (77 lb.)	35 N/mm (200 lb/in)
Weight of rider: 40 kg (88 lb.)	40 N/mm (228 lb/in)
Weight of rider: 45 kg (99 lb.)	45 N/mm (257 lb/in)

**i Info**  
The spring rate is shown on the outside of the spring.  
Smaller weight differences can be compensated by changing the spring preload.

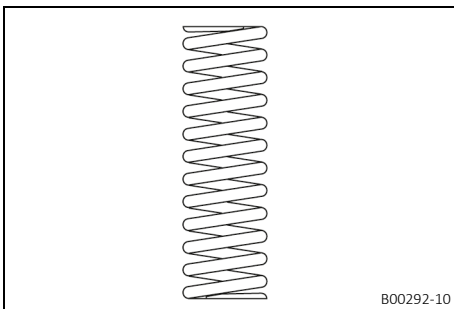

B00292-10

## Finishing work

- Install the shock absorber. (🔧 p. 49)
- Remove the motorcycle from the lift stand. (📖 p. 37)
- Check the static sag of the shock absorber. (📖 p. 31)
- Check the riding sag of the shock absorber. (📖 p. 32)
- Adjust the rebound damping of the shock absorber. (📖 p. 30)

## 10.12 Checking the basic setting of the fork

### **i** Info

For various reasons, no exact rider sag can be determined for the fork.

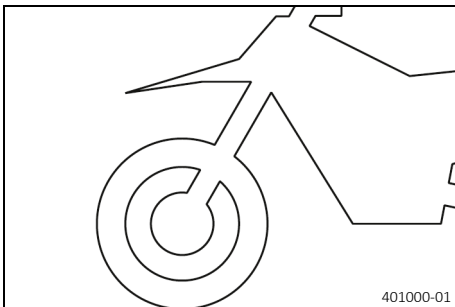

- Smaller differences in the rider's weight can be compensated for by the fork air pressure.
- However, if the fork frequently bottoms out (hard end stop on compression), the fork air pressure must be increased, within the specified values, to avoid damage to the fork and frame.

## 10.13 Adjusting the fork air pressure



### Warning

**Danger of accidents** Modifications to the suspension setting may seriously alter the handling characteristic.

Modifications which are not coordinated with others to the suspension setting may cause a serious deterioration in the handling characteristic and overload components.

- Only make adjustments within the recommended range.
- Make sure your child rides slowly to start with after making adjustments in order that he or she can assess the new handling characteristic.

### **i** Info

Check or adjust the air pressure under the same conditions at the earliest 5 minutes after switching off the engine. The air suspension is located in the left fork leg. The rebound damping is located in the right fork leg.

## Preparatory work

- Raise the motorcycle with a lift stand. (📖 p. 37)

## Main work

- Remove protection cap **1**.
- Push together fork airpump **2** fully.

Fork airpump (79412966100)

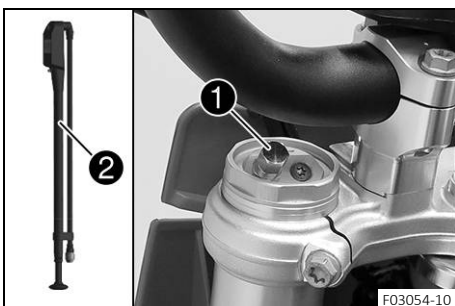

### **i** Info

The fork airpump is included as part of the motorcycle's accessory pack.

- Connect the fork airpump to the left fork leg.
  - ✓ The fork airpump indicator switches on automatically.

- ✓ A little air escapes from the fork leg when connecting.

**i Info**  
 This is due to the volume of the hose and not due to a defect in the fork airpump or the fork.  
 Observe the accompanying instructions for GASGAS technical accessories.

- Adjust the air pressure as specified.

Guideline

Air pressure	3 bar (44 psi)
Gradual changing of the air pressure in steps of	0.2 bar (3 psi)
Minimum air pressure	1.4 bar (20 psi)
Maximum air pressure	4 bar (58 psi)

**i Info**  
 Never adjust the air pressure to a value outside the stated range.

- Disconnect the fork airpump from the left fork leg.
  - ✓ When disconnecting, excess pressure will escape from the hose – the fork leg itself does not lose any air.
  - ✓ The fork airpump indicator switches off automatically after 80 seconds.
- Mount the protection cap.

**i Info**  
 Only mount the protection cap by hand.

**Finishing work**

- Remove the motorcycle from the lift stand. (📖 p. 37)



**10.14 Adjusting the rebound damping of the fork**

**i Info**  
 The hydraulic rebound damping determines the fork suspension behavior.



- Turn adjuster ① clockwise all the way.

**i Info**  
 Adjuster ① is located at the upper end of the right fork leg.

- Turn counterclockwise by the number of clicks corresponding to the fork type.

Guideline

Rebound damping	
Comfort	15 clicks
Standard	12 clicks
Sport	10 clicks

**i Info**  
Turn clockwise to increase the damping; turn counterclockwise to reduce damping when the shock absorber rebounds.

## 10.15 Handlebar position

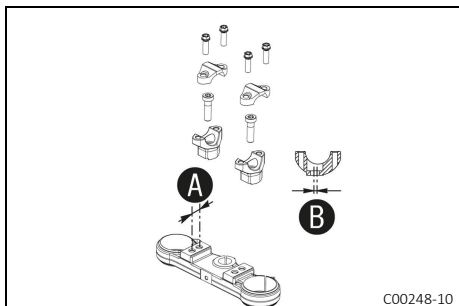

On the upper triple clamp, there are 2 holes at a distance of **A** to each other.

Hole distance <b>A</b>	15 mm (0.59 in)
------------------------	-----------------

The holes on the handlebar supports are placed at a distance of **B** from the center.

Hole distance <b>B</b>	3.5 mm (0.138 in)
------------------------	-------------------

The handlebar supports can be mounted in four different positions. This allows the handlebar to be mounted in the most comfortable position for the rider.

## 10.16 Adjusting the handlebar position



### Warning

**Danger of accidents** A repaired handlebar poses a safety risk.

If the handlebar is bent or straightened, the material becomes fatigued. The handlebar may break as a result.

- Change the handlebar if the handlebar is damaged or bent.

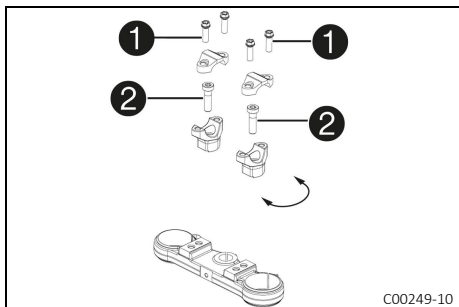

- Remove screws **1**. Take off the handlebar clamps. Remove the handlebar and lay it to one side.



### Info

Cover the components to protect them against damage. Do not kink the cables and lines.

- Remove screws **2**. Take off handlebar supports.
- Place handlebar supports in required position. Mount and tighten screws **2**.

Guideline

Screw, handlebar support	M10	40 Nm (29.5 lbf ft) <b>Loctite®243™</b>
--------------------------	-----	--

- Position the handlebar.



### Info

Make sure the cables and wiring are positioned correctly.

- Position the handlebar clamps. Mount screws **1** and tighten evenly.

Guideline

Screw, handlebar clamp	M8	20 Nm (14.8 lbf ft)
------------------------	----	---------------------



### Info

Make sure the installed gaps are even.

### 11.1 Raising the motorcycle with a lift stand

#### Note

**Material damage** The vehicle may be damaged by incorrect procedure when parking.

Significant damage may be caused if the vehicle rolls away or falls over.

The components for parking the vehicle are designed only for the weight of the vehicle.

- Park the vehicle on a firm and level surface.
- Ensure that nobody sits on the vehicle when the vehicle is parked on a stand.

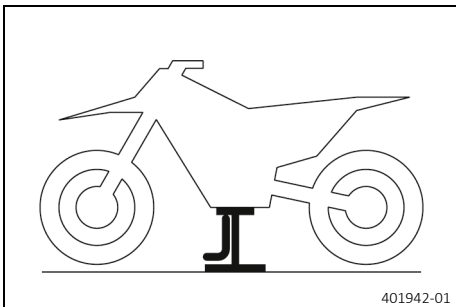

- Raise the motorcycle at the frame underneath the engine.
- ✓ Neither wheel is in contact with the ground.
- Secure the motorcycle against falling over.

### 11.2 Removing the motorcycle from the lift stand

#### Note

**Material damage** The vehicle may be damaged by incorrect procedure when parking.

Significant damage may be caused if the vehicle rolls away or falls over.

The components for parking the vehicle are designed only for the weight of the vehicle.

- Park the vehicle on a firm and level surface.
- Ensure that nobody sits on the vehicle when the vehicle is parked on a stand.

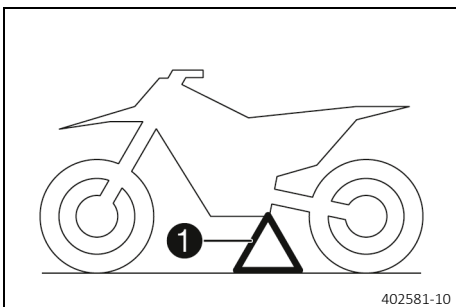

- Remove the motorcycle from the lift stand.
- Remove the lift stand.
- To park the motorcycle, insert plug-in stand ① into the plug-in stand bracket on the left side of the vehicle.



#### Info

Remove the plug-in stand before riding.

### 11.3 Bleeding the fork legs

#### Preparatory work

- Raise the motorcycle with a lift stand. (📖 p. 37)

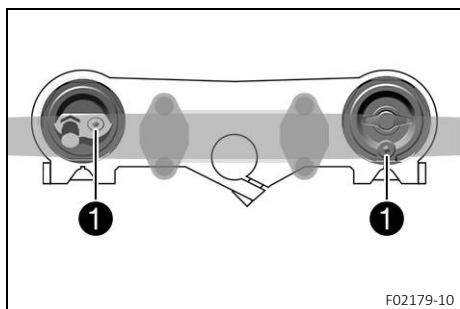

## Main work

- Release bleeder screws ①.
- ✓ Any excess pressure escapes from the interior of the fork.
- Tighten the bleeder screws.

## Finishing work

- Remove the motorcycle from the lift stand. (📖 p. 37)

## 11.4 Cleaning the dust boots of the fork legs

### Preparatory work

- Raise the motorcycle with a lift stand. (📖 p. 37)
- Remove the fork protector. (📖 p. 39)

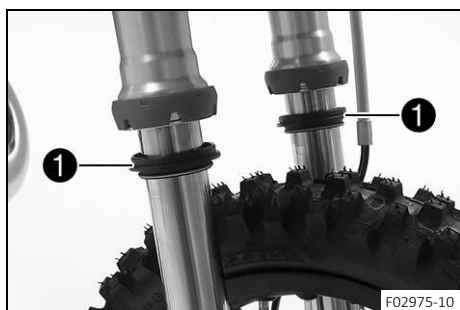

### Main work

- Push dust boots ① of both fork legs downward.

#### Info

The dust boots remove dust and coarse dirt particles from the inside fork tubes. Over time, dirt can accumulate behind the dust boots. If this dirt is not removed, the seals rings behind can start to leak.



#### Warning

**Danger of accidents** Oil or grease on the brake discs reduces the braking effect.

- Always keep the brake discs free of oil and grease.
- Clean the brake discs with brake cleaner when necessary.

- Clean and oil the dust boots and inside fork tubes of both fork legs.

Universal oil spray (📖 p. 110)

- Press the dust boots back into the installation position.
- Remove the excess oil.

### Finishing work

- Install the fork protector. (📖 p. 39)
- Remove the motorcycle from the lift stand. (📖 p. 37)



## 11.5 Removing the fork protector

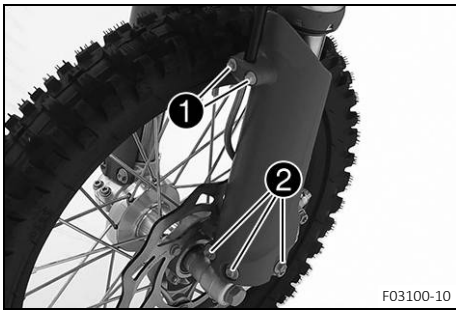

- Remove screws **1** and take off the clamp.
- Remove screws **2** on the left fork leg. Take off the fork protector.

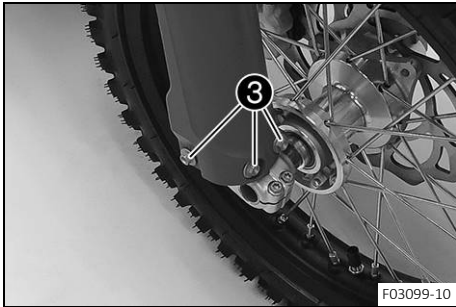

- Remove screws **3** on the right fork leg. Take off the fork protector.

## 11.6 Installing the fork protector

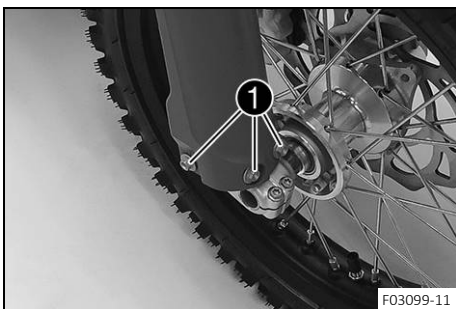

- Position the fork protector on the right fork leg. Mount and tighten screws **1**.

Guideline

Remaining screws, chassis	M6	10 Nm (7.4 lbf ft)
---------------------------	----	--------------------



- Position the fork protector on left fork leg. Mount and tighten screws **2**.

Guideline

Remaining screws, chassis	M6	10 Nm (7.4 lbf ft)
---------------------------	----	--------------------

- Position the brake line and the clamp. Mount and tighten screws **3**.

Guideline

Screw, brake hose bracket	<b>EJOT</b>	1.7 Nm (1.25 lbf ft)
---------------------------	-------------	----------------------

Clamp the brake line only via the metal bushing.

Make sure that the upper edge of the bushing is as flush as possible with the bracket.

## 11.7 Removing the fork legs

### Preparatory work

- Raise the motorcycle with a lift stand. (📖 p. 37)
- Remove the front wheel. (🔧 p. 76)

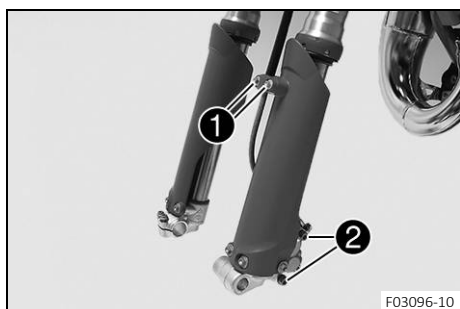

F03096-10

### Main work

- Remove screws 1 and take off the clamp.
- Remove screws 2 and take off the brake caliper.
- Allow the brake caliper and brake line to hang loosely to the side.



### Info

Do not kink the brake line.

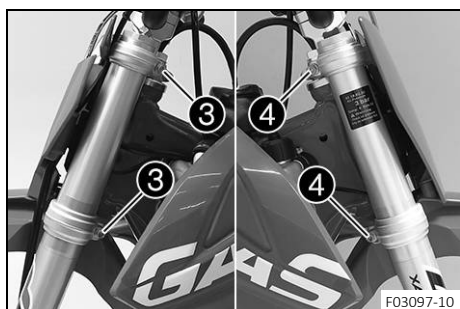

F03097-10

- Loosen screws 3. Remove the left fork leg.
- Loosen screws 4. Remove the right fork leg.

## 11.8 Installing the fork legs

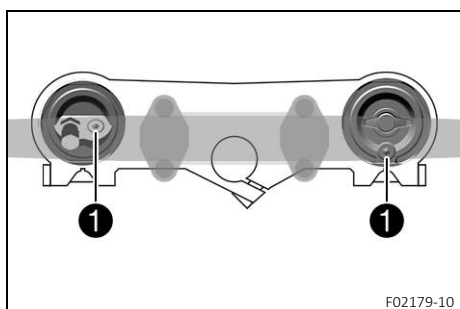

F02179-10

### Main work

- Position the fork legs.
- ✓ Bleeder screws 1 are positioned toward the rear.



### Info

The second milled groove in the fork leg must be flush with the upper edge of the upper triple clamp.

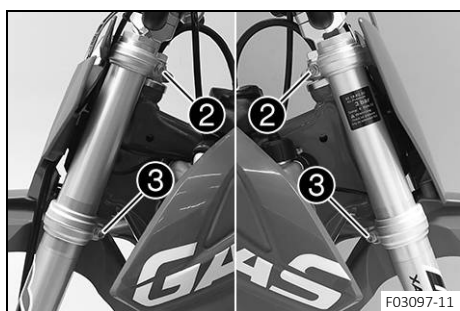

F03097-11

- Tighten screws 2.

### Guideline

Screw, top triple clamp	M8	20 Nm (14.8 lbf ft)
-------------------------	----	---------------------

- Tighten screws 3.

### Guideline

Screw, bottom triple clamp	M8	15 Nm (11.1 lbf ft)
----------------------------	----	---------------------

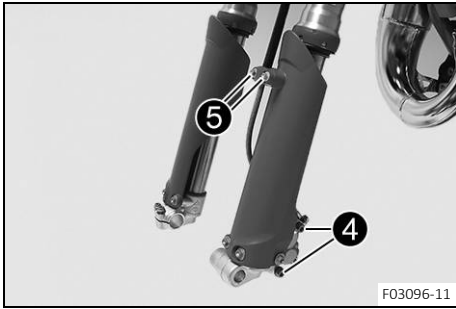

- Position the brake caliper, and mount and tighten screws **4**.

Guideline

Screw, front brake caliper	M8	20 Nm (14.8 lbf ft) <b>Loctite®243™</b>
----------------------------	----	--

- Position the brake line and the clamp. Mount and tighten screws **5**.

Guideline

Screw, brake hose bracket	<b>EJOT</b>	1.7 Nm (1.25 lbf ft)
---------------------------	-------------	----------------------

Clamp the brake line only via the metal bushing.
Make sure that the upper edge of the bushing is as flush as possible with the bracket.

### Finishing work

- Install the front wheel. 🛠️ (📖 p. 76)

## 11.9 Removing the lower triple clamp 🛠️

### Preparatory work

- Raise the motorcycle with a lift stand. (📖 p. 37)
- Remove the front wheel. 🛠️ (📖 p. 76)
- Remove the fork legs. 🛠️ (📖 p. 40)
- Remove the start number plate. (📖 p. 47)
- Remove front fender. (📖 p. 48)

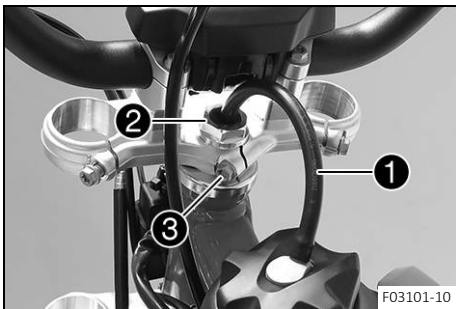

### Main work

- Pull fuel tank breather **1** out of the steering stem.
- Remove nut **2**.
- Release screw **3**, take off the upper triple clamp with the handlebar and set aside.

**i Info**  
Cover the components to protect them against damage.  
Do not kink the cables and lines.

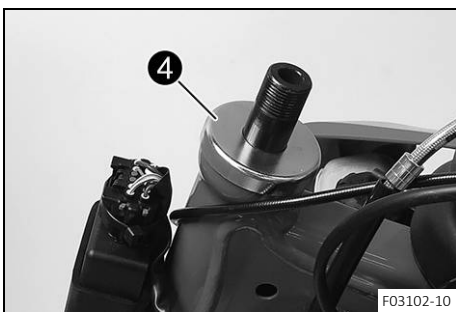

- Remove protective ring **4**.
- Remove the lower triple clamp with the steering stem.
- Remove the upper steering head bearing.

## 11.10 Installing the lower triple clamp

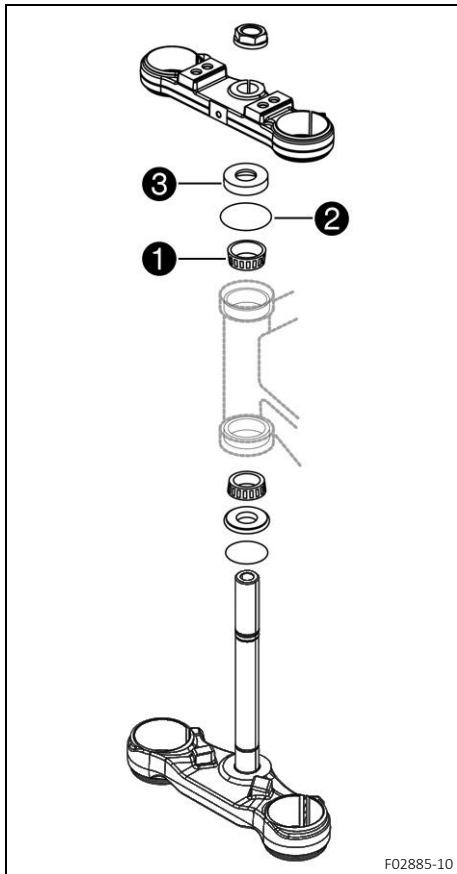

### Main work

- Clean the bearing and sealing elements, check for damage, and grease.
- High viscosity grease (📖 p. 109)
- Insert the lower triple clamp with the steering stem. Mount upper steering head bearing **1**.
  - Check whether upper steering head seal **2** is correctly positioned.
  - Push on protective ring **3**.



- Position the upper triple clamp and handlebar.
- Mount nut **4**, but do not tighten yet.

### Guideline

Nut, steering head	M20x1.5	10 Nm (7.4 lbf ft)
--------------------	---------	--------------------

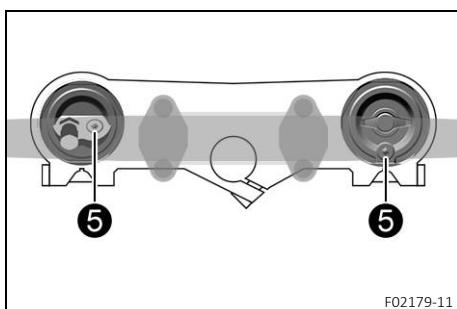

- Position the fork legs.
- ✓ Bleeder screws **5** are positioned toward the rear.



### Info

The second milled groove in the fork leg must be flush with the upper edge of the upper triple clamp.

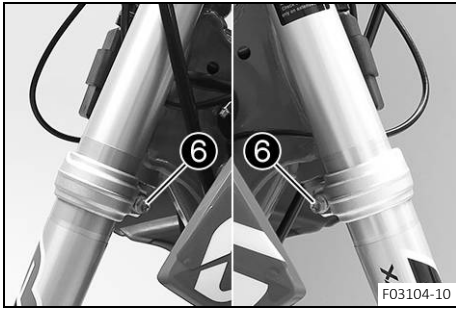

- Tighten screws **6**.

Guideline

Screw, bottom triple clamp	M8	15 Nm (11.1 lbf ft)
----------------------------	----	---------------------

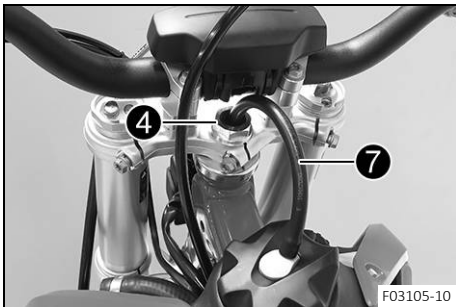

- Tighten nut **4**.

Guideline

Nut, steering head	M20x1.5	10 Nm (7.4 lbf ft)
--------------------	---------	--------------------

- Position the fuel tank breather **7** in the steering stem.

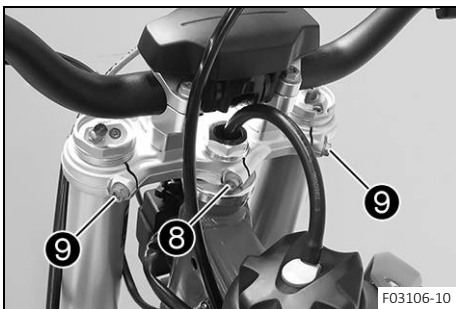

- Tighten bolt **8**.

Guideline

Screw, steering stem	M8	20 Nm (14.8 lbf ft)
----------------------	----	---------------------

- Using a plastic hammer, tap lightly on the upper triple clamp to avoid stresses.

- Tighten screws **9**.

Guideline

Screw, top triple clamp	M8	20 Nm (14.8 lbf ft)
-------------------------	----	---------------------

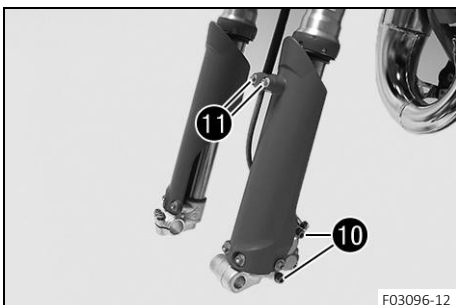

- Position the brake caliper, and mount and tighten screws **10**.

Guideline

Screw, front brake caliper	M8	20 Nm (14.8 lbf ft) <b>Loctite®243™</b>
----------------------------	----	--

- Position the brake line and the clamp. Mount and tighten screws **11**.

Guideline

Screw, brake hose bracket	<b>EJOT</b>	1.7 Nm (1.25 lbf ft)
---------------------------	-------------	----------------------

Clamp the brake line only via the metal bushing.

Make sure that the upper edge of the bushing is as flush as possible with the bracket.

### Finishing work

- Check that the wiring harness, throttle cable, and brake and clutch lines can move freely and are routed correctly.
- Install front fender. (📖 p. 48)
- Install the start number plate. (📖 p. 48)
- Install the front wheel. 🛠️ (📖 p. 76)
- Check the steering head bearing play. (📖 p. 44)
- Remove the motorcycle from the lift stand. (📖 p. 37)

## 11.11 Checking the steering head bearing play



### Warning

**Danger of accidents** Incorrect steering head bearing play impairs the handling characteristic and damages components.

- Correct incorrect steering head bearing play immediately. (Your authorized GASGAS Motorcycles workshop will be glad to help.)



### Info

If the vehicle is operated for a lengthy period with play in the steering head bearing, the bearings and the bearing seats in the frame can become damaged over time.

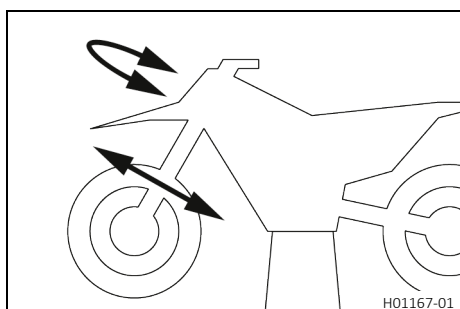

### Preparatory work

- Raise the motorcycle with a lift stand. (📖 p. 37)

### Main work

- Move the handlebar to the straight-ahead position. Move the fork legs to and fro in the direction of travel.

Play should not be detectable on the steering head bearing.

» If there is detectable play:

- Adjust the steering head bearing play. 🛠️ (📖 p. 44)

- Move the handlebar to and fro over the entire steering range.

It must be possible to move the handlebar easily over the entire steering range. There should be no detectable detent positions.

» If detent positions are detected:

- Adjust the steering head bearing play. 🛠️ (📖 p. 44)
- Check the steering head bearing and replace if required.

### Finishing work

- Remove the motorcycle from the lift stand. (📖 p. 37)

## 11.12 Adjusting the steering head bearing play 🛠️

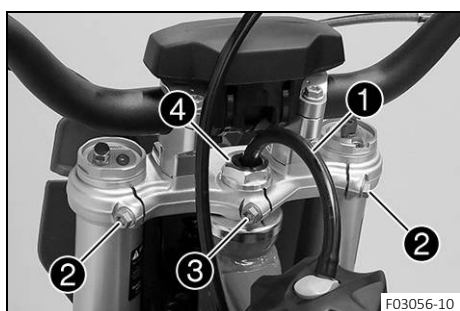

### Preparatory work

- Raise the motorcycle with a lift stand. (📖 p. 37)

### Main work

- Pull fuel tank breather ① out of the steering stem.
- Loosen screws ②.
- Loosen screw ③.
- Loosen and retighten nut ④.

#### Guideline

Nut, steering head	M20x1.5	10 Nm (7.4 lbf ft)
--------------------	---------	--------------------

- Using a plastic hammer, tap lightly on the upper triple clamp to avoid stresses.

- Tighten screw ③.

#### Guideline

Screw, steering stem	M8	20 Nm (14.8 lbf ft)
----------------------	----	---------------------

- Tighten screws ②.

## Guideline

Screw, top triple clamp	M8	20 Nm (14.8 lbf ft)
-------------------------	----	---------------------

- Position the fuel tank breather ❶ in the steering stem.

## Finishing work

- Check the steering head bearing play. (📖 p. 44)
- Remove the motorcycle from the lift stand. (📖 p. 37)



## 11.13 Lubricating the steering head bearing 🛠️

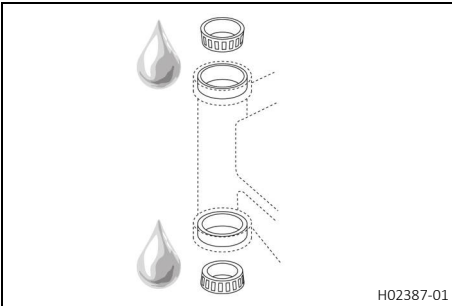

- Remove the lower triple clamp. 🛠️ (📖 p. 41)
- Install the lower triple clamp. 🛠️ (📖 p. 42)



## Info

The steering head bearing is cleaned and lubricated in the course of removal and installation of the lower triple clamp.



## 11.14 Removing the fuel tank 🛠️



## Danger

**Fire hazard** Fuel is highly flammable.

The fuel in the fuel tank expands when warm and can escape if overfilled.

- Do not fuel the vehicle in the vicinity of open flames or lit cigarettes.
- Switch off the engine for refueling.
- Make sure that no fuel is spilled; particularly not on hot parts of the vehicle.
- If any fuel is spilled, wipe it off immediately.
- Observe the specifications for refueling.



## Warning

**Danger of poisoning** Fuel is harmful to health.

- Avoid skin, eye and clothing contact with fuel.
- Immediately consult a doctor if you swallow fuel.
- Do not inhale fuel vapors.
- Rinse the affected area immediately with plenty of water in the event of contact with the skin.
- Rinse the eyes thoroughly with water, and consult a doctor in case of fuel contact with the eyes.
- Change your clothing if fuel spills on them.
- Keep fuels correctly in a suitable canister, and out of the reach of children.

## Preparatory work

- Remove the seat. (📖 p. 50)
- Turn the knurled screw on the fuel tap all the way clockwise.

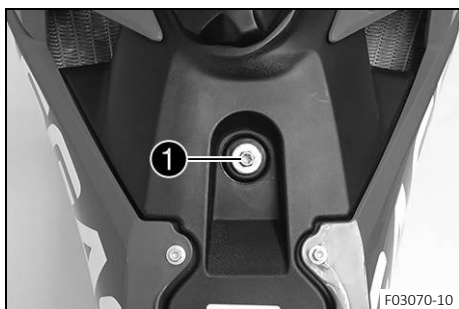

## Main work

- Remove screw ①.



- Remove screws ②.



- Pull off fuel hose ③.



### Info

Remaining fuel may flow out of the fuel hose.

- Pull fuel tank breather out of the steering stem.
- Pull both spoilers off laterally from the radiator bracket and lift off the fuel tank.

## 11.15 Installing the fuel tank ↩



### Danger

**Fire hazard** Fuel is highly flammable.

The fuel in the fuel tank expands when warm and can escape if overfilled.

- Do not fuel the vehicle in the vicinity of open flames or lit cigarettes.
- Switch off the engine for refueling.
- Make sure that no fuel is spilled; particularly not on hot parts of the vehicle.
- If any fuel is spilled, wipe it off immediately.
- Observe the specifications for refueling.



### Warning

**Danger of poisoning** Fuel is harmful to health.

- Avoid skin, eye and clothing contact with fuel.
- Immediately consult a doctor if you swallow fuel.
- Do not inhale fuel vapors.
- Rinse the affected area immediately with plenty of water in the event of contact with the skin.
- Rinse the eyes thoroughly with water, and consult a doctor in case of fuel contact with the eyes.
- Change your clothing if fuel spills on them.
- Keep fuels correctly in a suitable canister, and out of the reach of children.



## Main work

- Check the throttle cable routing. (🔧 p. 58)
- Position the fuel tank and fit the two spoilers to the sides of the radiator mount.
- Make sure that no cables or throttle cables are trapped or damaged.
- Mount fuel hose ❶.

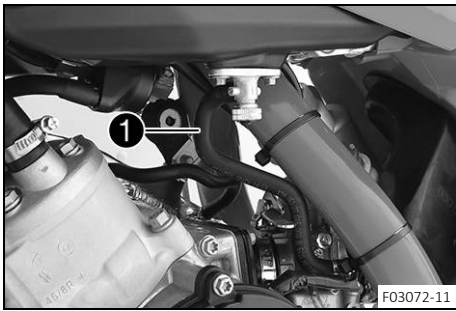

- Mount and tighten screws ❷.

### Guideline

Screw, fuel tank spoiler on radiator	M6	6 Nm (4.4 lbf ft)
--------------------------------------	----	-------------------

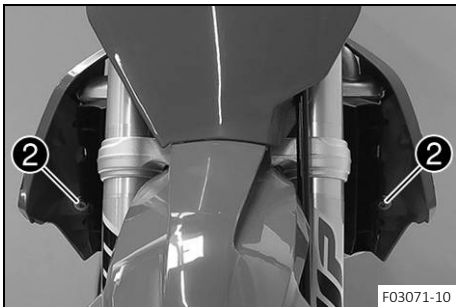

- Mount and tighten screw ❸.

### Guideline

Remaining screws, chassis	M6	10 Nm (7.4 lbf ft)
---------------------------	----	--------------------

- Position the fuel tank breather in the steering stem.



## Finishing work

- Mount the seat. (🔧 p. 50)

### 11.16 Removing the start number plate

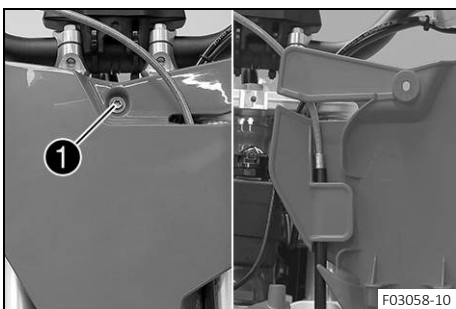

- Remove screw ❶.
- Unhook the start number plate from the brake line and remove it.

# 11 SERVICE WORK ON THE CHASSIS

## 11.17 Installing the start number plate

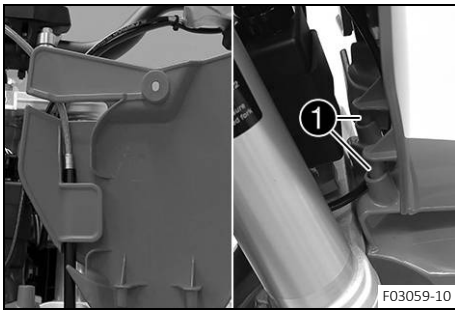

- Attach the start number plate to the brake line.
- Position the start number plate.
- ✓ Holding lugs **1** engage in the fender.

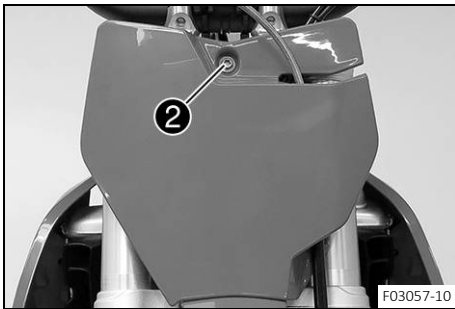

- Mount and tighten screw **2**.

Guideline

Start number plate screw	M6	4 Nm (3 lbf ft)
--------------------------	----	-----------------

## 11.18 Removing front fender

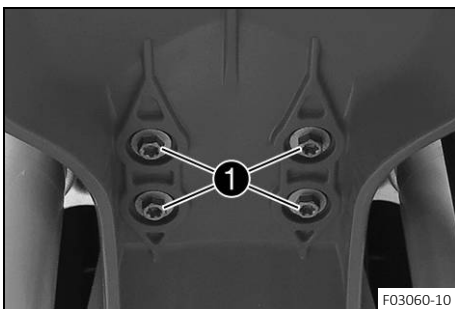

- Remove screws **1**. Take off the front fender.

## 11.19 Installing front fender

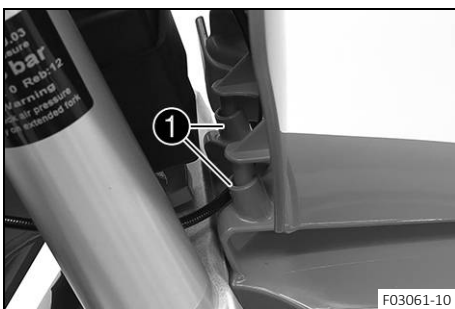

- Position start number plate on the fender.
- ✓ The holding lugs of the start number plate engage in drill holes **1** of the fender.

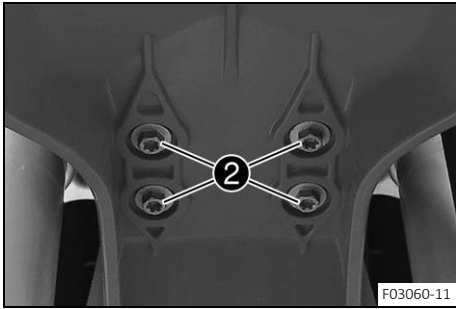

- Position fender on the lower triple clamp, mount and tighten screws **2**.

Guideline

Screw, fender	M6	6 Nm (4.4 lbf ft)
---------------	----	-------------------



## 11.20 Removing the shock absorber

### Preparatory work

- Raise the motorcycle with a lift stand. (📖 p. 37)

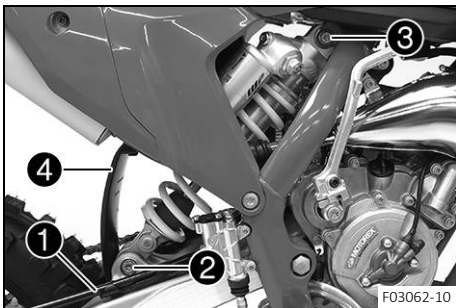

### Main work

- Pull brake line **1** out of the holder.
- Remove screw **2** and lower the rear wheel with the link fork as far as possible without blocking the rear wheel. Secure the rear wheel in this position.
- Remove screw **3**, push splash protector **4** to the side, and remove the shock absorber.



## 11.21 Installing the shock absorber

### Main work

- Push splash protector **1** to the side and position the shock absorber. Mount and tighten screw **2**.

Guideline

Screw, top shock absorber	M10	45 Nm (33.2 lbf ft) <b>Loctite®243™</b>
---------------------------	-----	--

- Raise the link fork, mount and tighten the shock absorber with screw **3**.

Guideline

Screw, bottom shock absorber	M10	45 Nm (33.2 lbf ft) <b>Loctite®243™</b>
------------------------------	-----	--

- Attach brake line **4** to the holder.

### Finishing work

- Remove the motorcycle from the lift stand. (📖 p. 37)



# 11 SERVICE WORK ON THE CHASSIS

## 11.22 Removing the seat

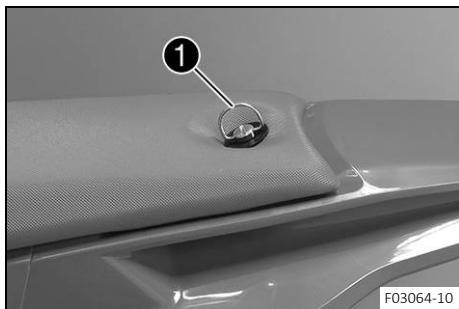

- Open quick release ① and raise the rear of the seat.
- Pull back the seat and remove it.

## 11.23 Mounting the seat

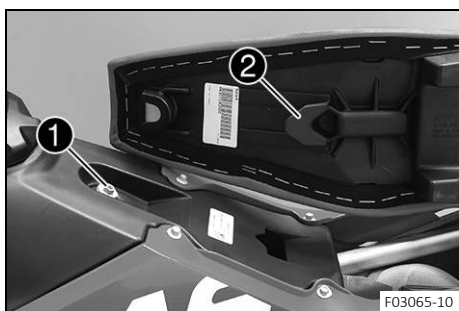

- Hook seat onto screw ① and lower the seat at the rear and push it forward.
  - ✓ Holding lug ② hooks into the fuel tank.

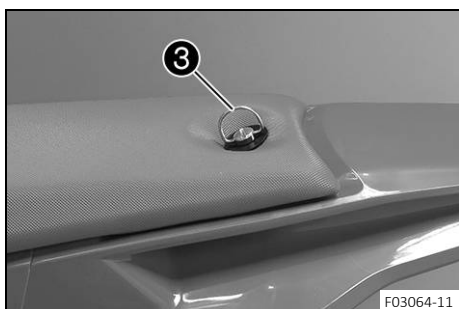

- Close quick release ③.

## 11.24 Removing the air filter

### Note

**Engine damage** Unfiltered intake air has a negative effect on the service life of the engine.

Dust and dirt will enter the engine without an air filter.

- Only operate the vehicle if it is equipped with an air filter.



### Note

**Environmental hazard** Hazardous substances cause environmental damage.

- Dispose of oils, grease, filters, fuel, cleaning agents, brake fluid, etc., correctly and in compliance with the applicable regulations.

### Preparatory work

- Remove the seat. (📖 p. 50)

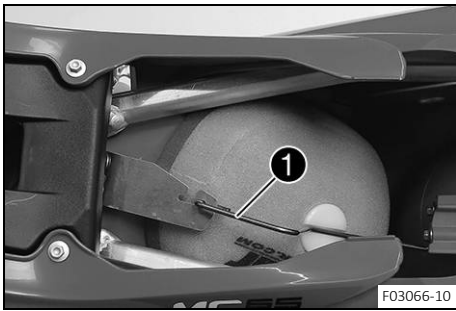

**Main work**

- Detach air filter holding bracket ① at the bottom and swing it to one side. Remove the air filter with the air filter support.
- Remove the air filter from the air filter support.



**11.25 Installing the air filter**

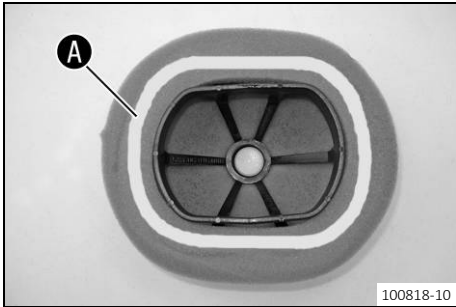

**Main work**

- Mount the clean air filter on the air filter support.
- Grease the air filter in area A.

Long-life grease (📖 p. 109)

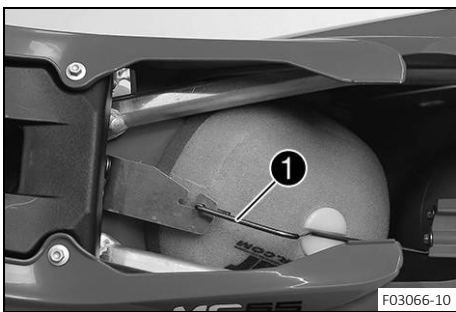

- Insert both parts together, position them, and secure them using air filter holding bracket ①.

**i Info**  
If the air filter is not mounted correctly, dust and dirt may enter the engine and result in damage.

**Finishing work**

- Mount the seat. (📖 p. 50)



**11.26 Cleaning the air filter and air filter box**



**Note**

**Environmental hazard** Hazardous substances cause environmental damage.

- Dispose of oils, grease, filters, fuel, cleaning agents, brake fluid, etc., correctly and in compliance with the applicable regulations.



**Info**

Do not clean the air filter with fuel or petroleum since these substances attack the foam.

**Preparatory work**

- Remove the seat. (📖 p. 50)
- Remove the air filter. (🔧📖 p. 50)

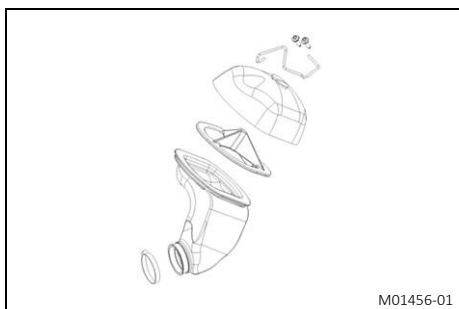

## Main work

- Wash the air filter thoroughly in special cleaning liquid and allow it to dry properly.

Air filter cleaner (📖 p. 109)

## Info

Only press the air filter to dry it, never wring it out.

- Oil the dry air filter with a high-grade air filter oil.

Oil for foam air filter (📖 p. 109)

- Clean the air filter box.
- Check intake flange for damage and looseness.

## Finishing work

- Install the air filter. 🛠️ (📖 p. 51)
- Mount the seat. (📖 p. 50)

## 11.27 Removing the main silencer



### Warning

**Danger of burns** The exhaust system gets hot when the vehicle is driven.

- Allow the exhaust system to cool down before performing any work on the vehicle.

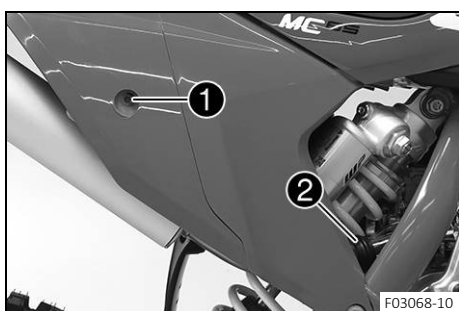

- Remove screw ①.
- Pull off the main silencer from the manifold at exhaust sleeve ②.

## 11.28 Installing the main silencer

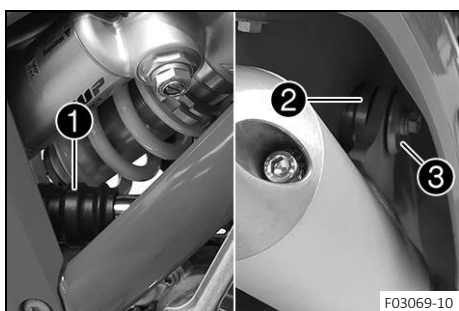

- Mount the main silencer with intake sleeve ①.
- Position wide collar bushing ② and narrow collar bushing ③.

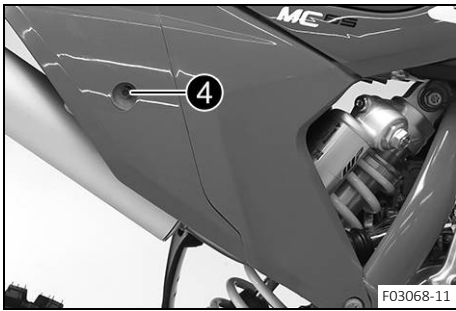

- Mount and tighten screw ④.

Guideline

Remaining screws, chassis	M6	10 Nm (7.4 lbf ft)
---------------------------	----	--------------------

**11.29 Changing the glass fiber yarn filling of the main silencer**



**Warning**

**Danger of burns** The exhaust system gets hot when the vehicle is driven.

- Allow the exhaust system to cool down before performing any work on the vehicle.



**Info**

Over time, the fibers of the glass fiber yarn filling escape and the damper "burns" out. Not only is the noise level higher, but the performance characteristics change.

**Preparatory work**

- Remove main silencer. (📖 p. 52)

**Main work**

- Remove screws with toothed washers ① from the silencer cap ②.
- Remove end cap and outer tube ③.
- Remove glass fiber yarn filling ④ from the inner tube.
- Clean the parts that need to be reinstalled and check for damage.
- Mount the new glass fiber yarn filling on the inner tube.
- Slide the outer tube over the glass fiber yarn filling.
- Insert the end cap into the outer tube.
- Mount and tighten the screws with the toothed washers.

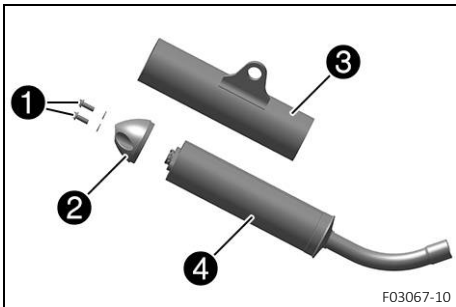

Guideline

Remaining screws, chassis	M6	10 Nm (7.4 lbf ft)
---------------------------	----	--------------------

**Finishing work**

- Install the main silencer. (📖 p. 52)

**11.30 Checking the chain for dirt**

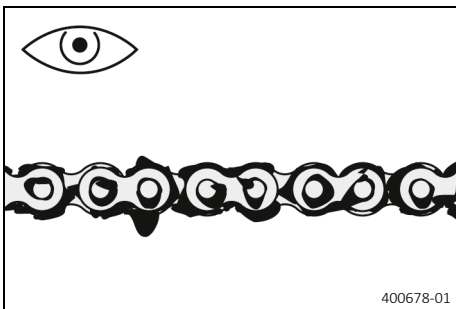

- Check the chain for coarse dirt accumulation.
  - » If the chain is very dirty:
    - Clean the chain. (📖 p. 54)

## 11.31 Cleaning the chain



### Warning

**Danger of accidents** Lubricants on the tires reduces the road grip.

- Remove lubricants from the tires using a suitable cleaning agent.



### Warning

**Danger of accidents** Oil or grease on the brake discs reduces the braking effect.

- Always keep the brake discs free of oil and grease.
- Clean the brake discs with brake cleaner when necessary.



### Note

**Environmental hazard** Hazardous substances cause environmental damage.

- Dispose of oils, grease, filters, fuel, cleaning agents, brake fluid, etc., correctly and in compliance with the applicable regulations.



### Info

The service life of the chain depends largely on its maintenance.

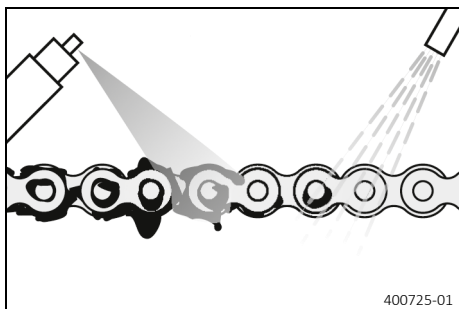

### Preparatory work

- Raise the motorcycle with a lift stand. (📖 p. 37)

### Main work

- Rinse off loose dirt with a soft jet of water.
- Remove old grease residue with chain cleaner.

Chain cleaner (📖 p. 109)

- After drying, apply chain spray.

Off-road chain spray (📖 p. 109)

### Finishing work

- Remove the motorcycle from the lift stand. (📖 p. 37)

## 11.32 Checking the chain tension



### Warning

**Danger of accidents** Incorrect chain tension damages components and results in accidents.

If the chain is tensioned too much, the chain, engine sprocket, rear sprocket, transmission and rear wheel bearings wear more quickly. Some components may break if overloaded.

If the chain is too loose, the chain may fall off the engine sprocket or the rear sprocket. As a result, the rear wheel locks or the engine will be damaged.

- Check the chain tension regularly.
- Set the chain tension in accordance with the specification.

### Preparatory work

- Raise the motorcycle with a lift stand. (📖 p. 37)



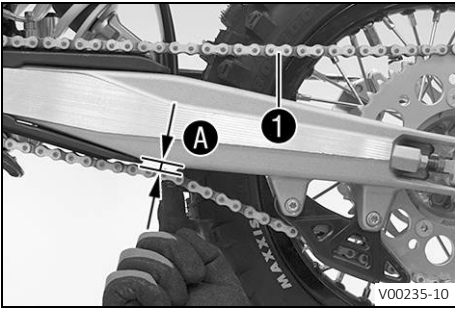

**Main work**

- Press the chain upward at the end of the chain sliding piece and determine chain tension **A**.

**i Info**

Top chain section **1** must be taut.  
Chain wear is not always even, so you should repeat this measurement at different chain positions.

Chain tension	5 ... 8 mm (0.2 ... 0.31 in)
---------------	------------------------------

- » If the chain tension does not meet the specification:
  - Adjust the chain tension. (📖 p. 55)

**Finishing work**

- Remove the motorcycle from the lift stand. (📖 p. 37)

**11.33 Adjusting the chain tension**



**Warning**

**Danger of accidents** Incorrect chain tension damages components and results in accidents.

If the chain is tensioned too much, the chain, engine sprocket, rear sprocket, transmission and rear wheel bearings wear more quickly. Some components may break if overloaded.

If the chain is too loose, the chain may fall off the engine sprocket or the rear sprocket. As a result, the rear wheel locks or the engine will be damaged.

- Check the chain tension regularly.
- Set the chain tension in accordance with the specification.

**Preparatory work**

- Raise the motorcycle with a lift stand. (📖 p. 37)
- Check the chain tension. (📖 p. 54)

**Main work**

- Loosen nut **1**.
- Loosen nuts **2**.
- Adjust the chain tension by turning adjusting screws **3** left and right.

Guideline

Chain tension	5 ... 8 mm (0.2 ... 0.31 in)
Turn the adjusting screws <b>3</b> on the left and right so that the markings on the left and right chain adjusters <b>4</b> are in the same position relative to the reference marks <b>A</b> . The rear wheel is then correctly aligned.	

- Tighten nuts **2**.
- Make sure that chain adjusters **4** are fitted correctly on adjusting screws **3**.
- Tighten nut **1**.

Guideline

Nut, rear wheel spindle	M14x1.5	40 Nm (29.5 lbf ft)
-------------------------	---------	---------------------

**Finishing work**

- Remove the motorcycle from the lift stand. (📖 p. 37)

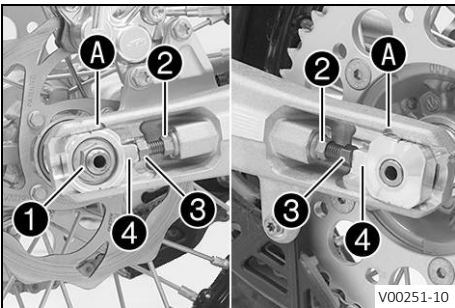

## 11.34 Checking the chain, rear sprocket, engine sprocket, and chain guide

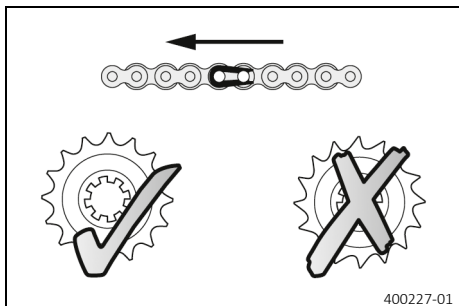

### Preparatory work

- Raise the motorcycle with a lift stand. (📖 p. 37)

### Main work

- Shift the transmission into neutral.
- Check the chain, rear sprocket, and engine sprocket for wear.
  - » If the chain, rear sprocket or motor sprocket is worn:
    - Change the drivetrain kit. 🛠️

### **i** Info

The engine sprocket, the rear sprocket, and the chain should always be replaced together. When fitting the chain joint, always make sure that the closed side of the joint faces forward (riding direction).

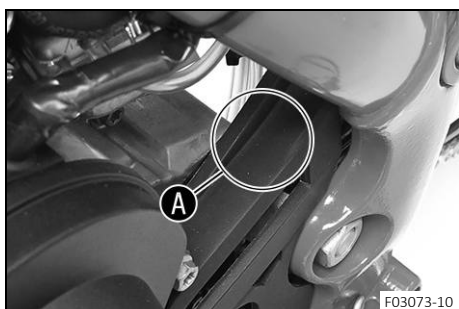

- Check the engine sprocket cover for wear.
  - » If the engine sprocket cover is worn through in the marked area **A**:
    - Change the engine sprocket cover. 🛠️
- Check the engine sprocket cover for tightness.
  - » If the engine sprocket cover is loose:
    - Tighten the engine sprocket cover.

### Guideline

Screw, engine sprocket cover	M6	10 Nm (7.4 lbf ft)
------------------------------	----	--------------------

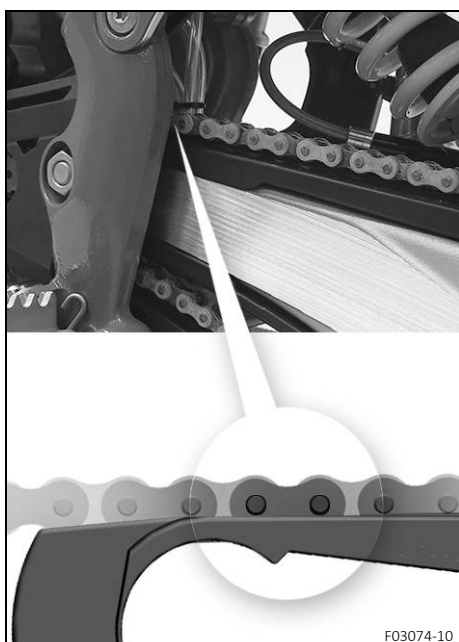

- Check the chain sliding guard for wear.
  - » If the lower edge of the chain pins is in line with, or below, the chain sliding guard:
    - Change the chain sliding guard. 🛠️
- Check that the chain sliding guard is firmly seated.
  - » If the chain sliding guard is loose:
    - Tighten the chain sliding guard.

### Guideline

Remaining screws, chassis	M6	10 Nm (7.4 lbf ft)
---------------------------	----	--------------------



- Check the chain sliding piece for wear.
  - » If the lower edge of the chain pins is in line with or below the chain sliding piece:
    - Change the chain sliding piece. 🛠️
- Check that the chain sliding piece is firmly seated.
  - » If the chain sliding piece is loose:
    - Tighten the chain sliding piece.

Guideline

Screw, chain sliding piece	M8	15 Nm (11.1 lbf ft)
----------------------------	----	---------------------

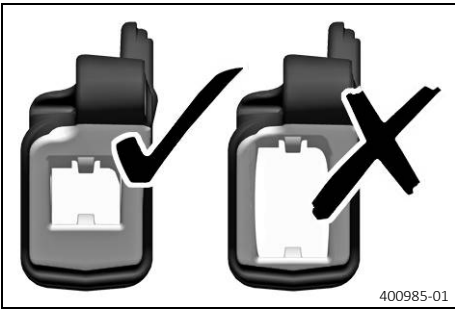

- Check the chain guide for wear.



**Info**

Wear can be seen on the front of the chain guide.

- » If the light part of the chain guide is worn:
  - Change the chain guide. 🛠️

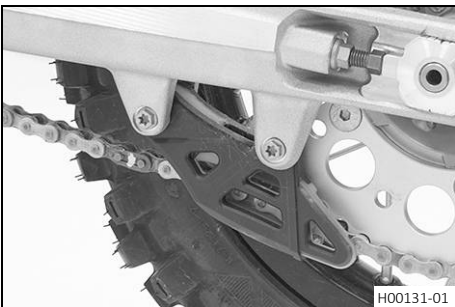

- Check that the chain guide is firmly seated.
  - » If the chain guide is loose:
    - Tighten the chain guide.

Guideline

Remaining screws, chassis	M6	10 Nm (7.4 lbf ft)
---------------------------	----	--------------------

**Finishing work**

- Remove the motorcycle from the lift stand. (📖 p. 37)

## 11.35 Checking the frame 🛠️

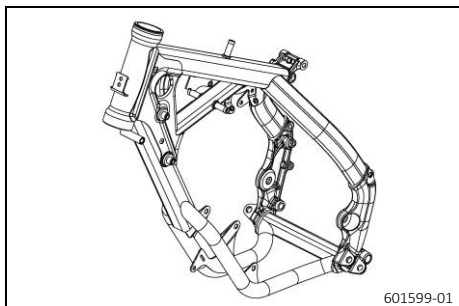

- Check the frame for damage, cracks, and deformation.
  - » If the frame shows signs of damage, cracks, or deformation:
    - Change the frame. 🛠️

Guideline

Repairs on the frame are not permitted.

## 11.36 Checking the link fork 🛠️

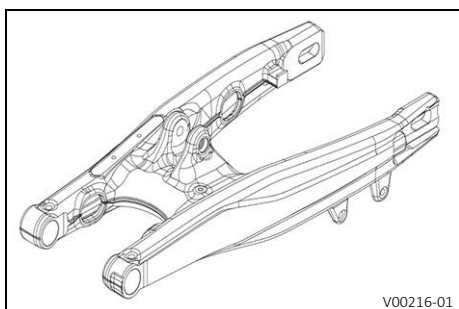

- Check the link fork for damage, cracks, and deformation.
  - » If the link fork shows signs of damage, cracks, or deformation:
    - Change the link fork. 🛠️

Guideline

Repairs on the link fork are not permitted.

## 11.37 Checking the throttle cable routing



### Warning

**Danger of accidents** The throttle cable can become kinked, trapped or blocked if it is not routed correctly.

If the throttle cable is kinked, trapped or blocked, the speed can no longer be controlled.

- Make sure that the throttle cable routing and the play in throttle cable complies with the specification.

### Preparatory work

- Remove the seat. (📖 p. 50)
- Turn the knurled screw on the fuel tap all the way clockwise.
- Remove the fuel tank. 🛠️ (📖 p. 45)

### Main work

- Check the throttle cable routing.

The throttle cable must be routed behind the handlebar, behind the coolant hose and on the left of the frame.

- » If the throttle cable is not routed as specified:
  - Correct the throttle cable routing.

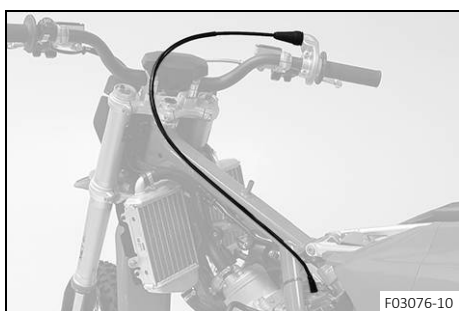

### Finishing work

- Install the fuel tank. 🛠️ (📖 p. 46)
- Mount the seat. (📖 p. 50)

**11.38 Checking the rubber grip**

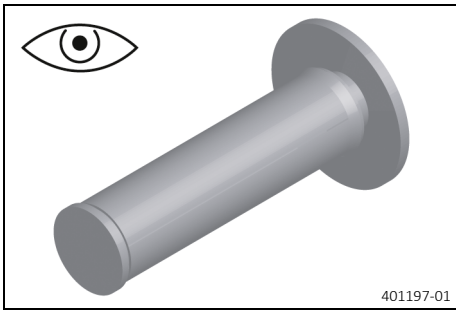

- Check the rubber grips on the handlebar for damage, wear, and looseness.



**Info**  
The rubber grips are vulcanized onto a sleeve on the left and onto the handle tube of the throttle grip on the right. The left sleeve is clamped onto the handlebar. The rubber grip can only be replaced with the sleeve or the throttle tube.

- » If a rubber grip is damaged or worn:
  - Change the rubber grip.

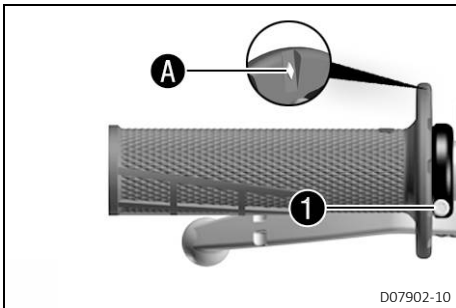

- Check that screw **1** is firmly seated.

Guideline

Screw, fixed grip	M4	5 Nm (3.7 lbf ft) <b>Loctite®243™</b>
-------------------	----	--

Diamond **A** must be located at the top.

**11.39 Additionally securing the rubber grip**

**Preparatory work**

- Check the rubber grip. (🔧 p. 59)

**Main work**

- Secure the rubber grip at two points using the securing wire.



Securing wire (54812016000)
Wire twister forceps (00029015100)

- ✓ The twisted wire ends face away from the hands and are bent toward the rubber grip.

**11.40 Adjusting the basic position of the clutch lever**

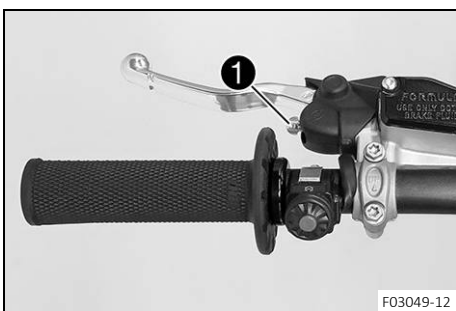

- Adjust the basic position of the clutch lever to the size of the rider's hand using adjusting screw **1**.



**Info**  
Turn the adjusting screw clockwise to increase the distance between the clutch lever and the handlebar. Turn the adjusting screw counterclockwise to decrease the distance between the clutch lever and the handlebar. The range of adjustment is limited. Turn the adjusting screw by hand only, and do not apply any force. Do not make any adjustments while riding.

## 11.41 Checking the fluid level of the hydraulic clutch

**i Info**  
The fluid level rises with increasing wear of the clutch facing discs.

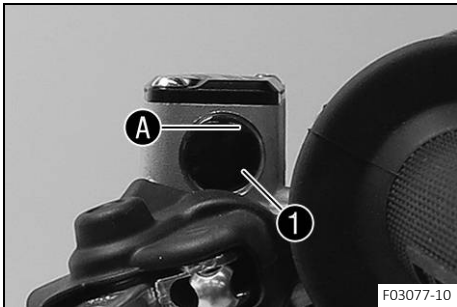

- Move the clutch fluid reservoir mounted on the handlebar to a horizontal position.
- Check the fluid level in viewer ①.
  - » If the fluid has dropped below marking A in the level viewer:
    - Correct the fluid level of the hydraulic clutch. (📖 p. 60)

## 11.42 Correcting the fluid level of the hydraulic clutch

**! Warning**  
**Skin irritation** Brake fluid is a harmful substance.

- Keep brake fluid out of the reach of children.
- Wear suitable protective clothing and safety glasses.
- Do not allow brake fluid to come into contact with the skin, the eyes or clothing.
- Consult a doctor immediately if brake fluid has been swallowed.
- Rinse the affected area with plenty of water in the event of contact with the skin.
- Rinse eyes thoroughly with water immediately and consult a doctor if brake fluid comes into contact with the eyes.
- If brake fluid spills on to your clothing, change the clothing.

**i Info**  
The fluid level rises with increasing wear of the clutch facing discs.  
Avoid contact between brake fluid and painted parts. Brake fluid corrodes paint.

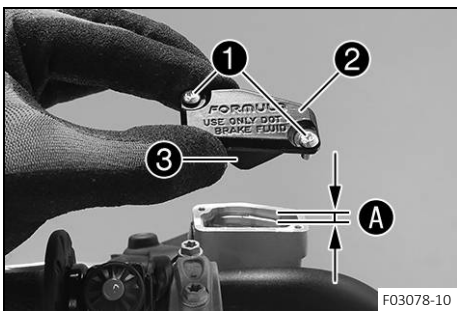

- Move the hydraulic clutch fluid reservoir mounted on the handlebar into a horizontal position.
- Remove screws ①.
- Take off cover ② with membrane ③.
- Correct the fluid up to level A.

Guideline

Level A (fluid level below container rim)	4 mm (0.16 in)
---	----------------

Brake fluid DOT 4 / DOT 5.1 (📖 p. 107)
--

- Position the cover with the membrane. Mount and tighten the screws.

**i Info**  
Use water to immediately clean up any brake fluid that has overflowed or spilled.

11.43 Changing the hydraulic clutch fluid 🐾



**Warning**

**Skin irritation** Brake fluid is a harmful substance.

- Keep brake fluid out of the reach of children.
- Wear suitable protective clothing and safety glasses.
- Do not allow brake fluid to come into contact with the skin, the eyes or clothing.
- Consult a doctor immediately if brake fluid has been swallowed.
- Rinse the affected area with plenty of water in the event of contact with the skin.
- Rinse eyes thoroughly with water immediately and consult a doctor if brake fluid comes into contact with the eyes.
- If brake fluid spills on to your clothing, change the clothing.



**Note**

**Environmental hazard** Hazardous substances cause environmental damage.

- Dispose of oils, grease, filters, fuel, cleaning agents, brake fluid, etc., correctly and in compliance with the applicable regulations.



**Info**

The fluid level rises with increasing wear of the clutch facing discs.  
Avoid contact between brake fluid and painted parts. Brake fluid corrodes paint.

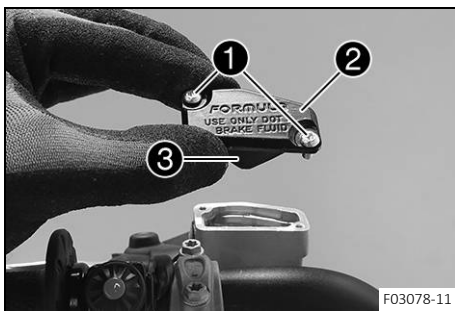

F03078-11

- Move the hydraulic clutch fluid reservoir mounted on the handlebar into a horizontal position.
- Remove screws **1**.
- Take off cover **2** with membrane **3**.

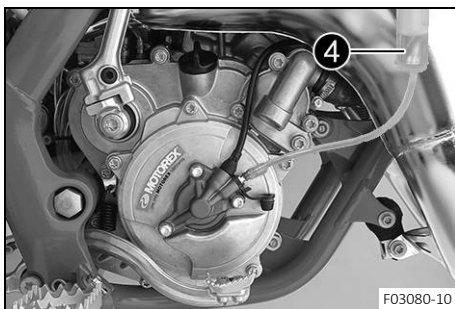

F03080-10

- Fill bleeder syringe **4** with the appropriate hydraulic fluid.

Syringe (50329050000)
Brake fluid DOT 4 / DOT 5.1 (📖 p. 107)

- On the slave cylinder, remove bleeder screw and mount bleeder syringe **4**.



F03079-10

- Now press the fluid into the system until it emerges from hole **5** of the master cylinder without bubbles.
- Occasionally extract the fluid from the master cylinder reservoir to prevent overflowing.
- Remove the bleeder syringe. Mount and tighten the bleeder screw.
- Correct the fluid level of the hydraulic clutch.

Guideline

Fluid level below container rim	4 mm (0.16 in)
---------------------------------	----------------

- Position the cover with the membrane. Mount and tighten the screws.

**Info**

Use water to immediately clean up any brake fluid that has overflowed or spilled.

---





**12.1 Checking the free travel of the hand brake lever**



**Warning**  
**Danger of accidents** The brake system fails in the event of overheating.

If there is no free travel on the hand brake lever, pressure builds up on the front brake circuit.

- Set the free travel on the hand brake lever in accordance with the specification.

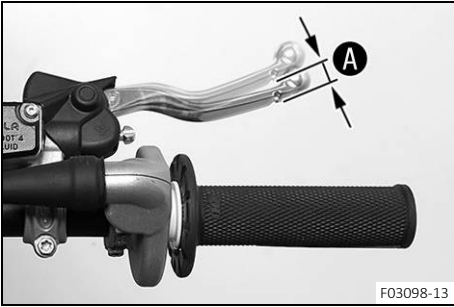

- Push the hand brake lever forward and check free travel **A**.

Free travel of hand brake lever	≥ 3 mm (≥ 0.12 in)
---------------------------------	--------------------

- » If the free travel does not match the specification:
  - Adjust the basic position of the hand brake lever. (📖 p. 63)

**12.2 Adjusting the basic position of the hand brake lever**

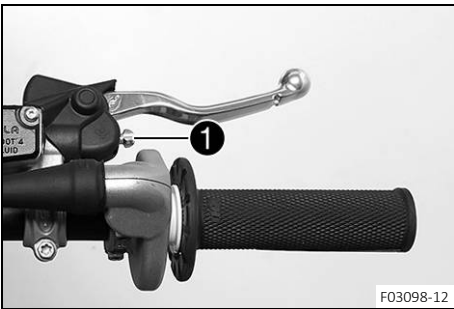

- Check the free travel of the hand brake lever. (📖 p. 63)
- Adjust the basic position of the hand brake lever using adjusting screw **1**.

**i Info**  
 Turn the adjusting screw clockwise to increase the distance between the hand brake lever and the handlebar.  
 Turn the adjusting screw counterclockwise to decrease the distance between the hand brake lever and the handlebar.  
 The range of adjustment is limited.  
 Turn the adjusting screw by hand only, and do not apply any force.  
 Do not make any adjustments while riding.

**12.3 Checking the brake discs**



**Warning**  
**Danger of accidents** Worn-out brake discs reduce the braking effect.

- Make sure that worn-out brake discs are replaced immediately. (Your authorized GASGAS Motorcycles workshop will be glad to help.)

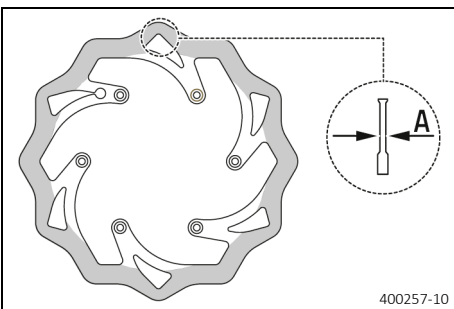

- Check the front and rear brake disc thickness at multiple points for the dimension **A**.

**i Info**  
 Wear reduces the thickness of the brake disc around the contact surface of the brake linings.

Brake discs - wear limits	
front	2.5 mm (0.098 in)
rear	2.5 mm (0.098 in)

- » If the brake disc thickness is less than the specified value:

- Change the front brake disc. 🛠️
- Change the rear brake disc. 🛠️
- Check the front and rear brake discs for damage, cracking, and deformation.
  - » If the brake disc exhibits damage, cracking, or deformation:
    - Change the front brake disc. 🛠️
    - Change the rear brake disc. 🛠️

## 12.4 Checking the front brake fluid level



### Warning

**Danger of accidents** An insufficient brake fluid level will cause the brake system to fail.

If the brake fluid level drops below the specified marking or the specified value, the brake system is leaking or the brake linings are worn down.

- Check the brake system and do not continue riding until the problem is eliminated. (Your authorized GAS-GAS Motorcycles workshop will be glad to help.)



### Warning

**Danger of accidents** Brake fluid which is too old or of the wrong type impairs the function of the brake system.

- Make sure that brake fluid for the front and rear brake is changed in accordance with the service schedule. (Your authorized GASGAS Motorcycles workshop will be glad to help.)
- Make sure that only clean, approved brake fluid from a tightly sealed container is used. (Your authorized GAS-GAS Motorcycles workshop will be glad to help.)

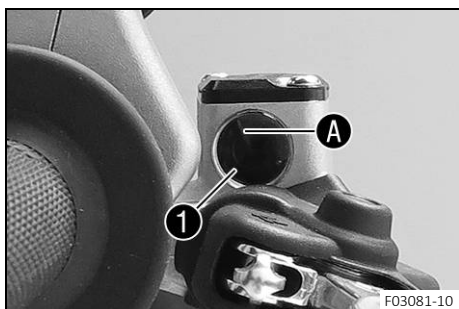

- Move the brake fluid reservoir mounted on the handlebar to a horizontal position.
- Check the brake fluid level in level viewer ①.
  - » If the brake fluid level has dropped below marking A in the level viewer:
    - Add front brake fluid. 🛠️ (📖 p. 64)

## 12.5 Adding front brake fluid 🛠️



### Warning

**Danger of accidents** An insufficient brake fluid level will cause the brake system to fail.

If the brake fluid level drops below the specified marking or the specified value, the brake system is leaking or the brake linings are worn down.

- Check the brake system and do not continue riding until the problem is eliminated. (Your authorized GAS-GAS Motorcycles workshop will be glad to help.)



**Warning**

**Skin irritation** Brake fluid is a harmful substance.

- Keep brake fluid out of the reach of children.
- Wear suitable protective clothing and safety glasses.
- Do not allow brake fluid to come into contact with the skin, the eyes or clothing.
- Consult a doctor immediately if brake fluid has been swallowed.
- Rinse the affected area with plenty of water in the event of contact with the skin.
- Rinse eyes thoroughly with water immediately and consult a doctor if brake fluid comes into contact with the eyes.
- If brake fluid spills on to your clothing, change the clothing.



**Warning**

**Danger of accidents** Brake fluid which is too old or of the wrong type impairs the function of the brake system.

- Make sure that brake fluid for the front and rear brake is changed in accordance with the service schedule. (Your authorized GASGAS Motorcycles workshop will be glad to help.)
- Make sure that only clean, approved brake fluid from a tightly sealed container is used. (Your authorized GASGAS Motorcycles workshop will be glad to help.)



**Note**

**Environmental hazard** Hazardous substances cause environmental damage.

- Dispose of oils, grease, filters, fuel, cleaning agents, brake fluid, etc., correctly and in compliance with the applicable regulations.



**Info**

Avoid contact between brake fluid and painted parts. Brake fluid corrodes paint.

**Preparatory work**

- Check that the brake linings of the front brake are secured. (📖 p. 66)

**Main work**

- Move the brake fluid reservoir mounted on the handlebar to a horizontal position.
- Remove screws ①.
- Take off cover ② with membrane ③.

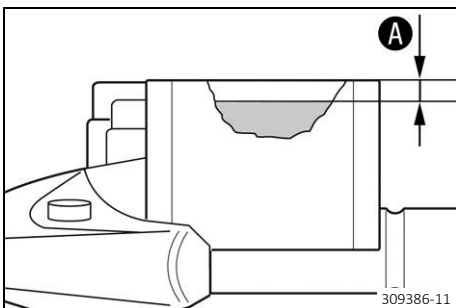
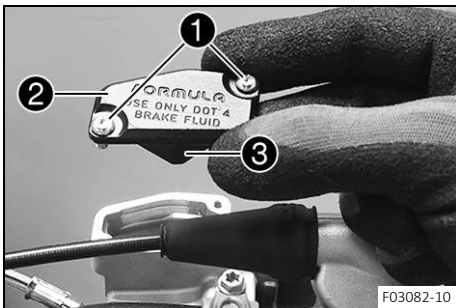

- Add brake fluid up to level A.

Guideline

Level A (brake fluid level below reservoir rim)	5 mm (0.2 in)
---	---------------

Brake fluid DOT 4 / DOT 5.1 (📖 p. 107)

- Position the cover with the membrane. Mount and tighten the screws.



**Info**

Use water to immediately clean up any brake fluid that has overflowed or spilled.

## 12.6 Checking that the brake linings of the front brake are secured



### Warning

**Danger of accidents** Worn-out brake linings reduce the braking effect.

- Ensure that worn-out brake linings are replaced immediately. (Your authorized GASGAS Motorcycles workshop will be glad to help.)

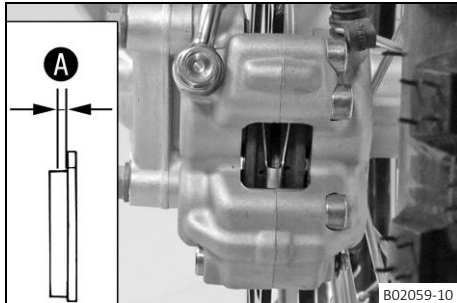

- Check the brake linings for lining thickness **A**.

Minimum thickness <b>A</b>	$\geq 1 \text{ mm } (\geq 0.04 \text{ in})$
----------------------------	---

- » If it is less than the minimum thickness:
  - Change the brake linings of the front brake. 🛠️ (📖 p. 66)
- Check the brake linings for damage and cracking.
  - » If there is damage or cracking:
    - Change the brake linings of the front brake. 🛠️ (📖 p. 66)
- Check that the brake linings are secured.
  - » If the brake linings are not secured correctly:
    - Secure brake linings, replace with new parts if necessary.

## 12.7 Changing the front brake linings 🛠️



### Warning

**Danger of accidents** Incorrect servicing will cause the brake system to fail.

- Ensure that service work and repairs are performed professionally. (Your authorized GASGAS Motorcycles workshop will be glad to help.)



### Warning

**Skin irritation** Brake fluid is a harmful substance.

- Keep brake fluid out of the reach of children.
- Wear suitable protective clothing and safety glasses.
- Do not allow brake fluid to come into contact with the skin, the eyes or clothing.
- Consult a doctor immediately if brake fluid has been swallowed.
- Rinse the affected area with plenty of water in the event of contact with the skin.
- Rinse eyes thoroughly with water immediately and consult a doctor if brake fluid comes into contact with the eyes.
- If brake fluid spills on to your clothing, change the clothing.



### Warning

**Danger of accidents** Brake fluid which is too old or of the wrong type impairs the function of the brake system.

- Make sure that brake fluid for the front and rear brake is changed in accordance with the service schedule. (Your authorized GASGAS Motorcycles workshop will be glad to help.)
- Make sure that only clean, approved brake fluid from a tightly sealed container is used. (Your authorized GASGAS Motorcycles workshop will be glad to help.)



## Warning

**Danger of accidents** Brake linings which have not been approved alter the braking efficiency.

Not all brake linings are tested and approved for GASGAS motorcycles. The structure and friction coefficient of the brake linings, and thus their brake power, may vary greatly from that of original brake linings.

If brake linings are used that differ from the original equipment, compliance with the original homologation is not guaranteed. In this case, the vehicle no longer corresponds to its condition at delivery and the manufacturer warranty shall be void.

- Only use brake linings approved and recommended by GASGAS.



## Note

**Environmental hazard** Hazardous substances cause environmental damage.

- Dispose of oils, grease, filters, fuel, cleaning agents, brake fluid, etc., correctly and in compliance with the applicable regulations.



## Info

Avoid contact between brake fluid and painted parts. Brake fluid corrodes paint.

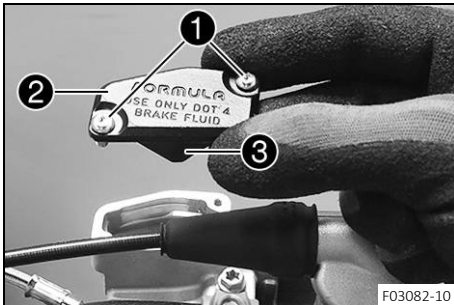

- Move the brake fluid reservoir mounted on the handlebar to a horizontal position.
- Remove screws **1**.
- Take off cover **2** with membrane **3**.

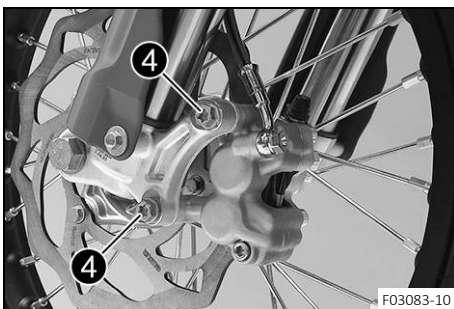

- Remove screws **4**.
- Press back the brake linings by slightly tilting the brake caliper laterally on the brake disc. Carefully pull the brake caliper backward from the brake disc.
- Press the brake piston back into the basic position and ensure that brake fluid does not flow out of the brake fluid reservoir; extract some if necessary.

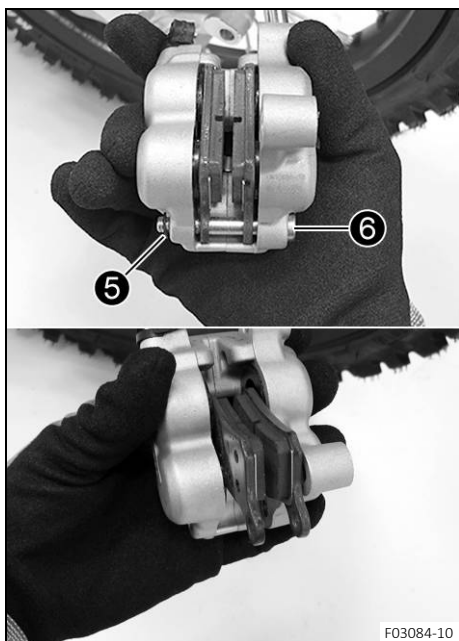

- Remove lock ring ⑤.
- Remove screw ⑥.
- Remove the brake linings.
- Clean the brake caliper and the brake caliper bracket.



### Warning

**Danger of accidents** Brake linings which have not been approved alter the braking efficiency.

Not all brake linings are tested and approved for GASGAS motorcycles. The structure and friction coefficient of the brake linings, and thus their brake power, may vary greatly from that of original brake linings.

If brake linings are used that differ from the original equipment, compliance with the original homologation is not guaranteed. In this case, the vehicle no longer corresponds to its condition at delivery and the manufacturer warranty shall be void.

- Only use brake linings approved and recommended by GASGAS.

- Position the new brake linings.



### Info

Always change the brake linings in pairs. Ensure that the brake linings are correctly positioned in the holding spring.

- Mount and tighten screw ⑥.

#### Guideline

Screw, front brake linings	M6	10 Nm (7.4 lbf ft)
----------------------------	----	--------------------

- Mount lock ring ⑤.



### Warning

**Danger of accidents** Oil or grease on the brake discs reduces the braking effect.

- Always keep the brake discs free of oil and grease.
- Clean the brake discs with brake cleaner when necessary.

- Check the brake discs. (📖 p. 63)
- Position the brake caliper.
- Mount screws ④, but do not tighten yet.
- Operate the hand brake lever repeatedly until the brake linings are in contact with the brake disc and there is a pressure point. Secure the hand brake lever in the activated position.

✓ The brake caliper straightens.

- Tighten screws ④.

#### Guideline

Screw, front brake caliper	M8	20 Nm (14.8 lbf ft) <b>Loctite®243™</b>
----------------------------	----	--

- Remove the locking piece of the hand brake lever.

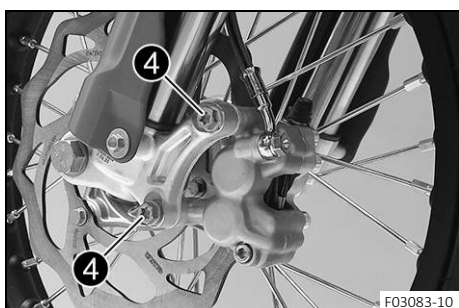

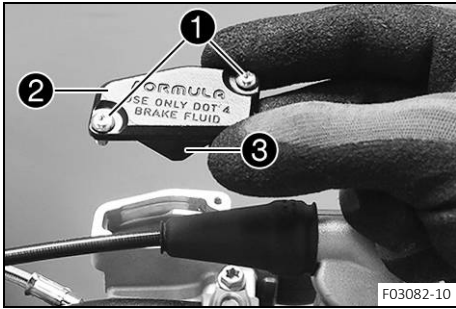

- Correct the brake fluid level.

Guideline

Brake fluid level below reservoir rim	5 mm (0.2 in)
---------------------------------------	---------------

Brake fluid DOT 4 / DOT 5.1 (📖 p. 107)
--

- Position cover **2** with membrane **3**.
- Mount and tighten screws **1**.

**i Info**  
Use water to immediately clean up any brake fluid that has overflowed or spilled.



### 12.8 Checking the free travel of the foot brake lever

**Warning**  
**Danger of accidents** The brake system will fail if it overheats or is adjusted incorrectly.

If there is no free travel on the foot brake lever, pressure builds up in the brake system on the rear brake.

- Set the free travel on the foot brake lever in accordance with the specification.
- Ensure that the adjustment steps are performed properly. (Your authorized GASGAS Motorcycles workshop will be glad to help.)

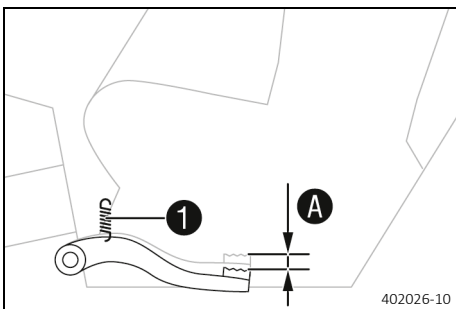

- Detach spring **1**.
- Move the foot brake lever back and forth between the end stop and the contact to the foot brake cylinder piston and check free travel **A**.

Guideline

Free travel of foot brake lever	3 ... 5 mm (0.12 ... 0.2 in)
---------------------------------	------------------------------

- » If the free travel does not match the specification:
  - Adjust the free travel of the hand brake lever. 🗨️ (📖 p. 69)
- Attach spring **1**.



### 12.9 Adjusting the free travel of the foot brake lever 🗨️

**Warning**  
**Danger of accidents** The brake system will fail if it overheats or is adjusted incorrectly.

If there is no free travel on the foot brake lever, pressure builds up in the brake system on the rear brake.

- Set the free travel on the foot brake lever in accordance with the specification.
- Ensure that the adjustment steps are performed properly. (Your authorized GASGAS Motorcycles workshop will be glad to help.)

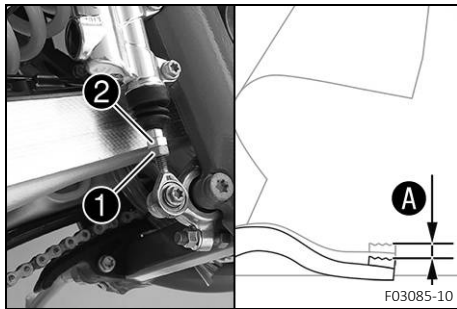

- Detach the foot brake lever spring.
- Loosen nut ①.
- Turn push rod ② accordingly until you have free travel A.

Guideline

Free travel of foot brake lever	3 ... 5 mm (0.12 ... 0.2 in)
---------------------------------	------------------------------

- Hold push rod ② and tighten nut ①.
- Attach the foot brake lever spring.
- Check whether the basic position of the foot brake lever is suitable for the rider.
  - » When the basic position of the foot brake lever needs to be adjusted:
    - Adjust the basic position of the foot brake lever. 📖 (p. 70)

## 12.10 Adjusting the basic position of the foot brake lever 📖



### Warning

**Danger of accidents** The brake system will fail if it overheats or is adjusted incorrectly.

If there is no free travel on the foot brake lever, pressure builds up in the brake system on the rear brake.

- Set the free travel on the foot brake lever in accordance with the specification.
- Ensure that the adjustment steps are performed properly. (Your authorized GASGAS Motorcycles workshop will be glad to help.)

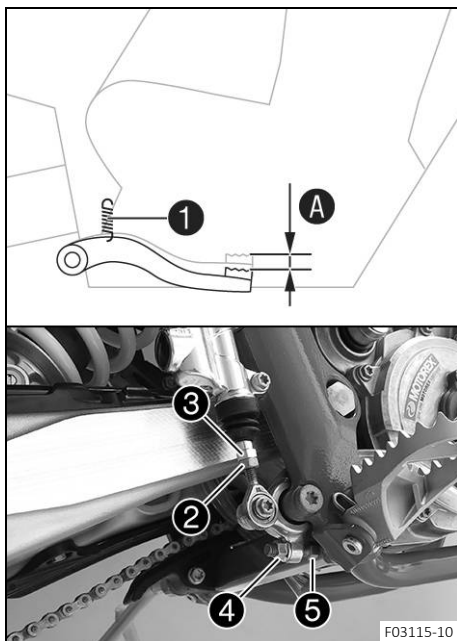

- Detach spring ①.
- Loosen nut ② and, with push rod ③, turn it back until you have maximum free travel.
- To adjust the basic position of the foot brake lever to individual requirements, loosen nut ④ and turn screw ⑤ accordingly.



### Info

The range of adjustment is limited.

- Turn push rod ③ accordingly until you have free travel A. If necessary, adjust the basic position of the foot brake lever.

Guideline

Free travel of foot brake lever	3 ... 5 mm (0.12 ... 0.2 in)
---------------------------------	------------------------------

- Hold screw ⑤ and tighten nut ④.

Guideline

Brake lever stop nut	M8	20 Nm (14.8 lbf ft)
----------------------	----	---------------------

- Hold push rod ③ and tighten nut ②.

Guideline

Remaining nuts, chassis	M6	10 Nm (7.4 lbf ft)
-------------------------	----	--------------------

- Attach spring ①.



### 12.11 Checking the rear brake fluid level



#### Warning

**Danger of accidents** An insufficient brake fluid level will cause the brake system to fail.

If the brake fluid level drops below the specified marking or the specified value, the brake system is leaking or the brake linings are worn down.

- Check the brake system and ensure that nobody drives the vehicle before the problem is eliminated. (Your authorized GASGAS Motorcycles workshop will be glad to help.)



#### Warning

**Danger of accidents** Brake fluid which is too old or of the wrong type impairs the function of the brake system.

- Make sure that brake fluid for the front and rear brake is changed in accordance with the service schedule. (Your authorized GASGAS Motorcycles workshop will be glad to help.)
- Make sure that only clean, approved brake fluid from a tightly sealed container is used. (Your authorized GASGAS Motorcycles workshop will be glad to help.)

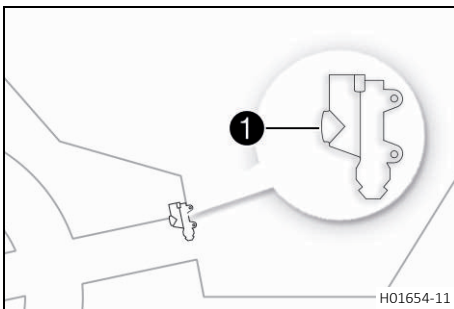

- Position the vehicle upright.
- Check the brake fluid level in level viewer ①.
  - » If an air bubble is visible in viewer ①:
    - Add rear brake fluid. 📖 (p. 71)

### 12.12 Adding rear brake fluid 📖



#### Warning

**Danger of accidents** An insufficient brake fluid level will cause the brake system to fail.

If the brake fluid level drops below the specified marking or the specified value, the brake system is leaking or the brake linings are worn down.

- Check the brake system and ensure that nobody drives the vehicle before the problem is eliminated. (Your authorized GASGAS Motorcycles workshop will be glad to help.)



#### Warning

**Skin irritation** Brake fluid is a harmful substance.

- Keep brake fluid out of the reach of children.
- Wear suitable protective clothing and safety glasses.
- Do not allow brake fluid to come into contact with the skin, the eyes or clothing.
- Consult a doctor immediately if brake fluid has been swallowed.
- Rinse the affected area with plenty of water in the event of contact with the skin.
- Rinse eyes thoroughly with water immediately and consult a doctor if brake fluid comes into contact with the eyes.
- If brake fluid spills on to your clothing, change the clothing.



## Warning

**Danger of accidents** Brake fluid which is too old or of the wrong type impairs the function of the brake system.

- Make sure that brake fluid for the front and rear brake is changed in accordance with the service schedule. (Your authorized GASGAS Motorcycles workshop will be glad to help.)
- Make sure that only clean, approved brake fluid from a tightly sealed container is used. (Your authorized GASGAS Motorcycles workshop will be glad to help.)



## Note

**Environmental hazard** Hazardous substances cause environmental damage.

- Dispose of oils, grease, filters, fuel, cleaning agents, brake fluid, etc., correctly and in compliance with the applicable regulations.



## Info

Avoid contact between brake fluid and painted parts. Brake fluid corrodes paint.

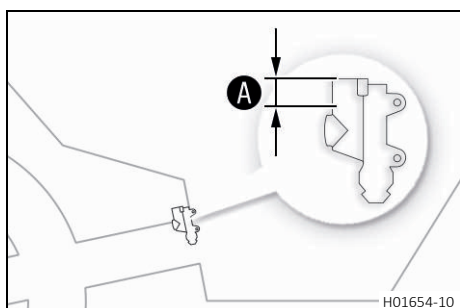
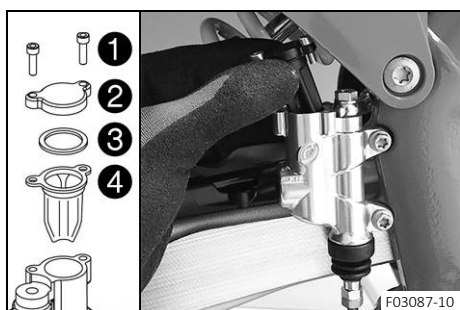

## Preparatory work

- Raise the motorcycle with a lift stand. (📖 p. 37)
- Check that the brake linings of the rear brake are secured. (📖 p. 73)

## Main work

- Remove screws **1**.
- Take off cover **2** with washer **3** and membrane **4**.

- Add brake fluid up to level **A**.

Guideline

Level <b>A</b> (brake fluid level below reservoir rim)	10 mm (0.39 in)
--	-----------------

Brake fluid DOT 4 / DOT 5.1 (📖 p. 107)

- Position cover with washer and membrane.
- Mount and tighten the screws.



## Info

Use water to immediately clean up any brake fluid that has overflowed or spilled.

## Finishing work

- Remove the motorcycle from the lift stand. (📖 p. 37)

### 12.13 Checking that the brake linings of the rear brake are secured



#### Warning

**Danger of accidents** Worn-out brake linings reduce the braking effect.

- Ensure that worn-out brake linings are replaced immediately. (Your authorized GASGAS Motorcycles workshop will be glad to help.)

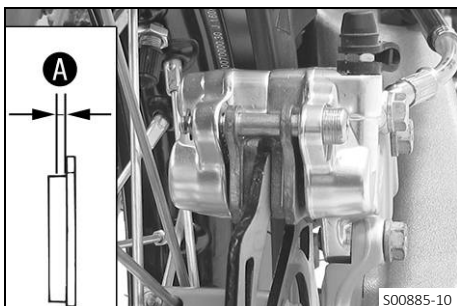

- Check the brake linings for lining thickness **A**.

Minimum thickness <b>A</b>	$\geq 1 \text{ mm } (\geq 0.04 \text{ in})$
----------------------------	---

- » If it is less than the minimum thickness:
  - Change the rear brake linings. (p. 73)
- Check the brake linings for damage and cracking.
  - » If there is damage or cracking:
    - Change the rear brake linings. (p. 73)
- Check that the brake linings are secured.
  - » If the brake linings are not secured correctly:
    - Secure brake linings, replace with new parts if necessary.



### 12.14 Changing the rear brake linings



#### Warning

**Danger of accidents** Incorrect servicing will cause the brake system to fail.

- Ensure that service work and repairs are performed professionally. (Your authorized GASGAS Motorcycles workshop will be glad to help.)



#### Warning

**Skin irritation** Brake fluid is a harmful substance.

- Keep brake fluid out of the reach of children.
- Wear suitable protective clothing and safety glasses.
- Do not allow brake fluid to come into contact with the skin, the eyes or clothing.
- Consult a doctor immediately if brake fluid has been swallowed.
- Rinse the affected area with plenty of water in the event of contact with the skin.
- Rinse eyes thoroughly with water immediately and consult a doctor if brake fluid comes into contact with the eyes.
- If brake fluid spills on to your clothing, change the clothing.



#### Warning

**Danger of accidents** Brake fluid which is too old or of the wrong type impairs the function of the brake system.

- Make sure that brake fluid for the front and rear brake is changed in accordance with the service schedule. (Your authorized GASGAS Motorcycles workshop will be glad to help.)
- Make sure that only clean, approved brake fluid from a tightly sealed container is used. (Your authorized GASGAS Motorcycles workshop will be glad to help.)



#### Warning

**Danger of accidents** Oil or grease on the brake discs reduces the braking effect.

- Always keep the brake discs free of oil and grease.
- Clean the brake discs with brake cleaner when necessary.



## Warning

**Danger of accidents** Brake linings which have not been approved alter the braking efficiency.

Not all brake linings are tested and approved for GASGAS motorcycles. The structure and friction coefficient of the brake linings, and thus their brake power, may vary greatly from that of original brake linings.

If brake linings are used that differ from the original equipment, compliance with the original homologation is not guaranteed. In this case, the vehicle no longer corresponds to its condition at delivery and the manufacturer warranty shall be void.

- Only use brake linings approved and recommended by GASGAS.



## Note

**Environmental hazard** Hazardous substances cause environmental damage.

- Dispose of oils, grease, filters, fuel, cleaning agents, brake fluid, etc., correctly and in compliance with the applicable regulations.



## Info

Avoid contact between brake fluid and painted parts. Brake fluid corrodes paint.

### Preparatory work

- Raise the motorcycle with a lift stand. (📖 p. 37)

### Main work

- Remove lock ring **1**.
- Remove screw **2**.
- Remove screw **3** and screw **4**.

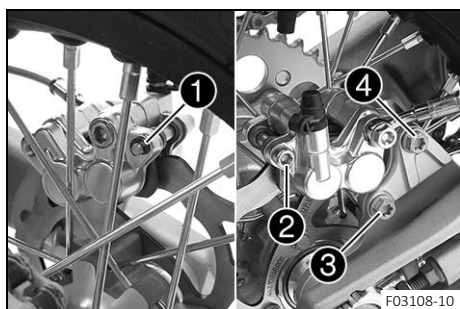

- Take off the brake caliper.



### Info

Do not kink or damage the brake line.

- Remove the brake linings.
- Clean the brake caliper and the brake caliper bracket.
- Allow the brake caliper and the brake line to hang loosely to the side.



- Remove screws **5**.
- Take off cover **6** with washer **7** and membrane **8**.
- Press the brake piston back to its basic position and make sure that no brake fluid overflows from the brake fluid reservoir, extract brake fluid if necessary.

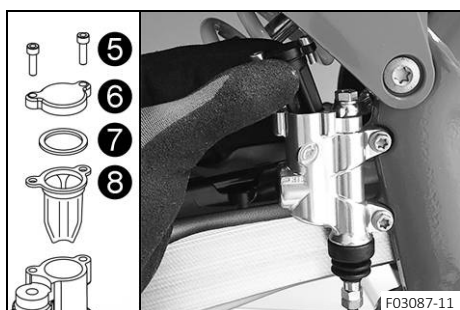



- Position the new brake linings.

**i Info**  
Always change the brake linings in pairs.  
Ensure that the brake linings are correctly positioned in the holding spring.

- Position the brake caliper on the brake disc.  
✓ The brake linings are correctly positioned.

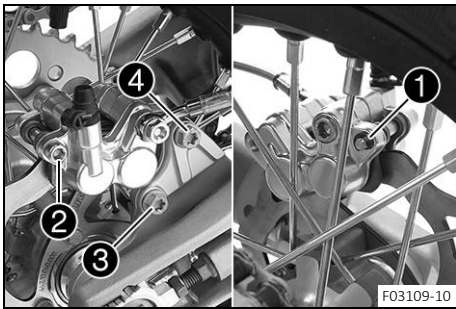

- Mount and tighten screw **3**.

Guideline		
Screw, rear brake caliper	M8x20	18 Nm (13.3 lbf ft) <b>Loctite®243™</b>

- Mount and tighten screw **4**.

Guideline		
Screw, rear brake caliper	M8x40	18 Nm (13.3 lbf ft) <b>Loctite®243™</b>

- Mount and tighten screw **2**.

Guideline		
Screw, rear brake lining	M6	10 Nm (7.4 lbf ft)

- Mount lock ring **1**.
- Check the brake discs. (📖 p. 63)
- Operate the foot brake lever repeatedly until the brake linings are in contact with the brake disc and there is a pressure point.

- Add brake fluid up to level **A**.

Guideline		
Level <b>A</b> (brake fluid level below reservoir rim)		10 mm (0.39 in)

Brake fluid DOT 4 / DOT 5.1 (📖 p. 107)
--

- Position cover with washer and membrane.
- Mount and tighten the screws.

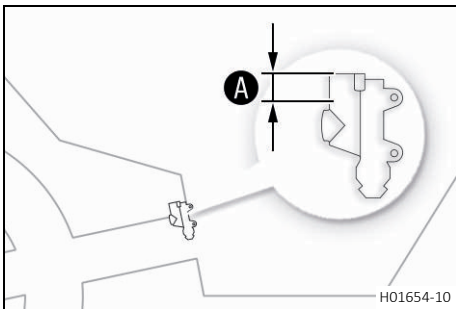

**i Info**  
Use water to immediately clean up any brake fluid that has overflowed or spilled.

**Finishing work**

- Remove the motorcycle from the lift stand. (📖 p. 37)



## 13.1 Removing the front wheel

### Preparatory work

- Raise the motorcycle with a lift stand. (📖 p. 37)

### Main work

- Loosen screw ❶ by several rotations.
- Loosen screws ❷.
- Press on screw ❶ to push the wheel spindle out of the axle clamp.
- Remove screw ❶.

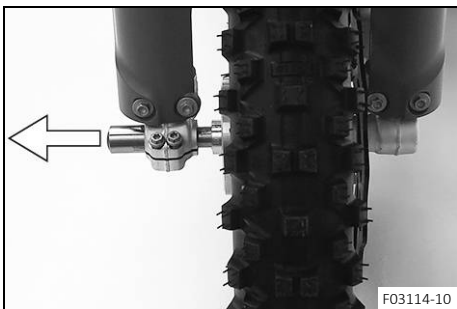
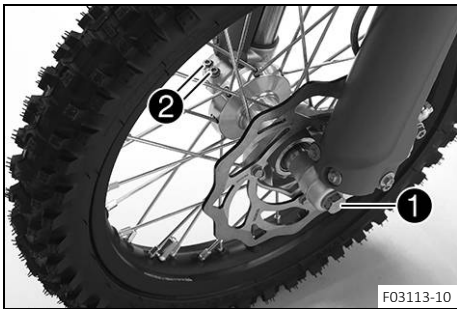

### Warning

**Danger of accidents** Damaged brake discs reduce the braking effect.

- Always lay the wheel down in such a way that the brake disc is not damaged.

- Hold front wheel and remove wheel spindle. Take the front wheel out of the fork.



### Info

Do not actuate the hand brake lever when the front wheel is removed.

- Remove spacers ❸.

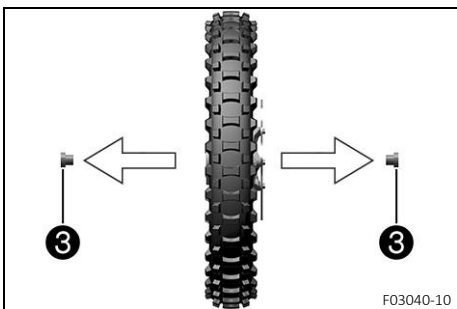

## 13.2 Installing the front wheel



### Warning

**Danger of accidents** Oil or grease on the brake discs reduces the braking effect.

- Always keep the brake discs free of oil and grease.
- Clean the brake discs with brake cleaner when necessary.

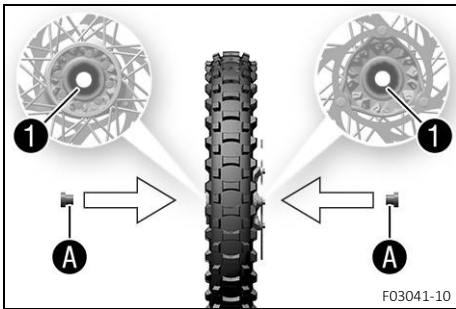

- Check the wheel bearing for damage and wear.
  - » If the wheel bearing is damaged or worn:
    - Change front wheel bearing. 🛠️
- Clean and grease shaft seal rings 1 and contact surfaces A of the spacers.

Long-life grease (📖 p. 109)

- Insert the spacers.

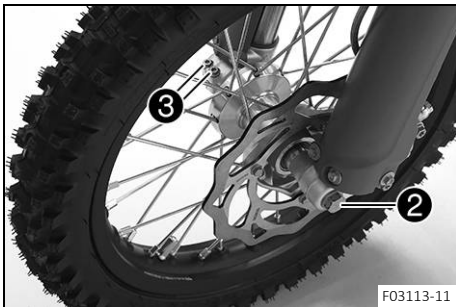

- Clean and grease the wheel spindle.

Long-life grease (📖 p. 109)

- Position the front wheel.
  - ✓ The brake linings are correctly positioned.
- Insert the wheel spindle.
- Mount and tighten screw 2.

Guideline

Screw, front wheel spindle	M10	40 Nm (29.5 lbf ft) <b>Loctite® 243™</b>
----------------------------	-----	---

- Operate the hand brake lever several times until the brake linings are seated correctly against the brake disc.
- Remove the motorcycle from the lift stand. (📖 p. 37)
- Operate the front brake and compress the fork a few times firmly.
  - ✓ The fork legs straighten.
- Tighten screws 3.

Guideline

Screw, fork stub	M6	10 Nm (7.4 lbf ft)
------------------	----	--------------------

**13.3 Removing the rear wheel 🛠️**

**Preparatory work**

- Raise the motorcycle with a lift stand. (📖 p. 37)

**Main work**

- Remove nut 1.
- Take off chain adjuster 2.

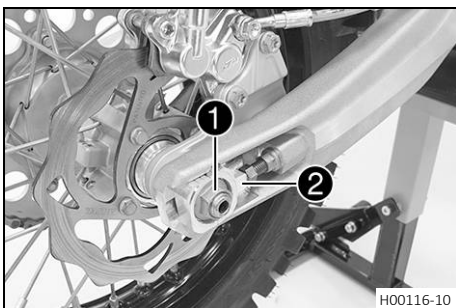

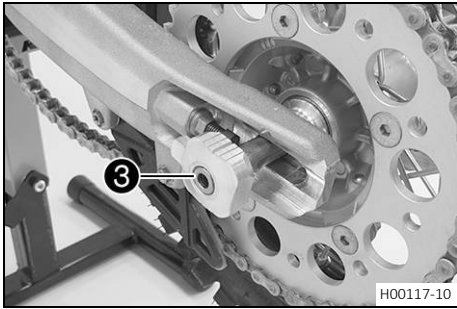

- Pull out wheel spindle **3** far enough to allow the rear wheel to be pushed forward.
- Push the rear wheel forward as far as possible. Remove the chain from the rear sprocket.



**Info**

Cover the components to protect them against damage.



**Warning**

**Danger of accidents** Damaged brake discs reduce the braking effect.

- Always lay the wheel down in such a way that the brake disc is not damaged.

- Hold the rear wheel and remove the wheel spindle. Take the rear wheel out of the link fork.



**Info**

Do not operate the foot brake lever when the rear wheel is removed.

- Remove spacers **4**.

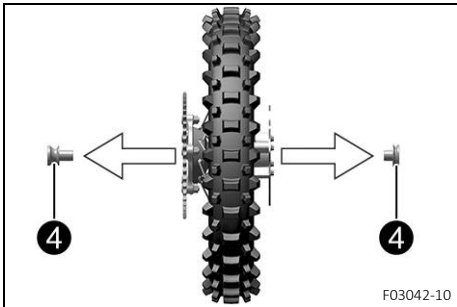

## 13.4 Installing the rear wheel ↩



**Warning**

**Danger of accidents** Oil or grease on the brake discs reduces the braking effect.

- Always keep the brake discs free of oil and grease.
- Clean the brake discs with brake cleaner when necessary.

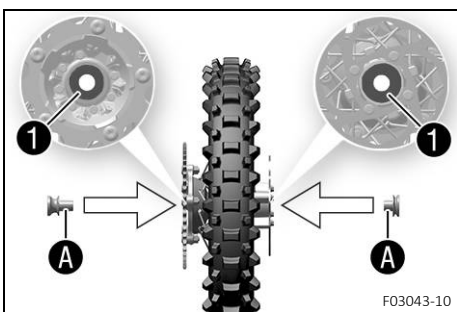

**Main work**

- Check the wheel bearing for damage and wear.
  - » If the wheel bearing is damaged or worn:
    - Change the rear wheel bearing. ↩
- Clean and grease shaft seal rings **1** and contact surfaces **A** of the spacers.

Long-life grease (🔧 p. 109)

- Insert the spacers.



**Info**

Insert the wide spacer on the left in the direction of travel.



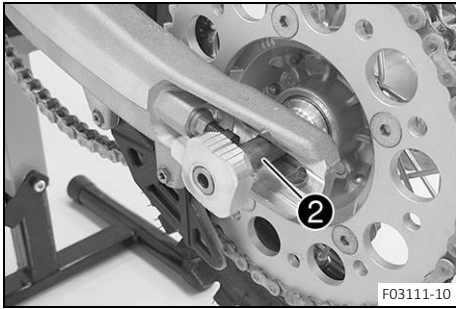

- Clean and grease the wheel spindle.

Long-life grease (📖 p. 109)

- Position rear wheel and mount the chain.
  - ✓ The brake linings are correctly positioned.
- Insert wheel spindle ②.

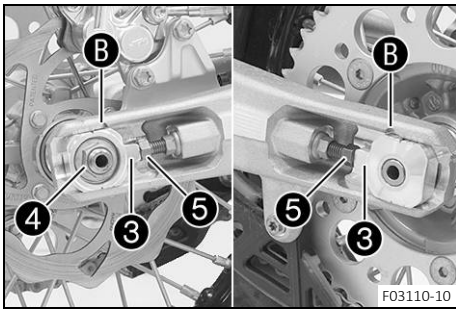

- Position chain adjuster ③. Mount nut ④, but do not tighten it yet.
- Make sure that chain adjusters ③ are fitted correctly on adjusting screws ⑤.
- Make sure that the markings on the left and right chain adjusters ③ are in the same position relative to reference marks B. The rear wheel is then correctly aligned.

**i Info**  
 The wide adjustment range of the chain adjusters enables different secondary ratios with the same chain length.  
 Chain adjusters ③ can be turned by 180°.

- Check the chain tension. (📖 p. 54)
- Tighten nut ④.

Guideline

Nut, rear wheel spindle	M14x1.5	40 Nm (29.5 lbf ft)
-------------------------	---------	---------------------

- Operate the foot brake lever repeatedly until the brake linings are in contact with the brake disc and there is a pressure point.

**Finishing work**

- Remove the motorcycle from the lift stand. (📖 p. 37)

**13.5 Checking the tire condition**

**i Info**  
 Only mount tires approved and/or recommended by GASGAS.  
 Other tires could have a negative effect on handling characteristics.  
 The type, condition, and pressure of the tires all have a major impact on the handling characteristics of the motorcycle.  
 The tires mounted on the front and rear wheels must have a similar profile.  
 Worn tires have a negative effect on handling characteristics, especially on wet surfaces.

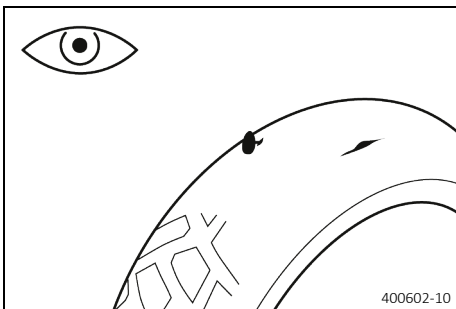

- Check the front and rear tires for cuts, embedded objects, and other damage.
  - » If the tires have cuts, run-in objects, or other damage:
    - Change the tires. 🛠️

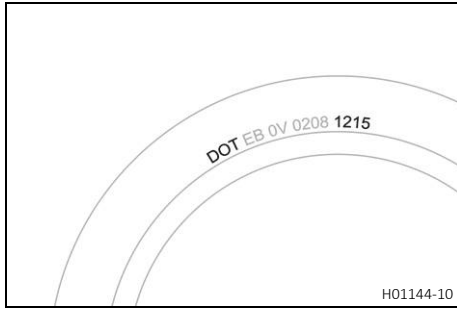

- Check the tire age.



**Info**

The tire date of manufacture is usually contained in the tire label and is indicated by the last four digits of the **DOT** number. The first two digits indicate the week of manufacture and the last two digits the year of manufacture.

GASGAS recommends that the tires be changed after 5 years at the latest, regardless of the actual state of wear.

- » If the tires are older than five years:
  - Change the tires. 🛠️

## 13.6 Checking tire pressure



**Info**

Low tire pressure leads to abnormal wear and overheating of the tire. Correct tire pressure ensures optimal riding comfort and maximum tire service life.

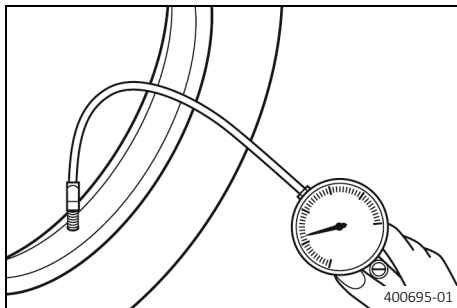

- Remove protection cap.
- Check tire pressure when the tires are cold.

Offroad tire pressure	
front	1.0 bar (15 psi)
rear	1.0 bar (15 psi)

- » If the tire pressure does not meet specifications:
  - Correct tire pressure.
- Mount the protection cap.

## 13.7 Checking the spoke tension



**Warning**

**Danger of accidents** Incorrectly tensioned spokes impair the handling characteristic and result in secondary damage.

The spokes break due to being overloaded if they are too tightly tensioned. If the tension in the spokes is too low, then lateral and radial run-out will form in the wheel. Other spokes will become looser as a result.

- Check spoke tension regularly, and in particular on a new vehicle. (Your authorized GASGAS Motorcycles workshop will be glad to help.)

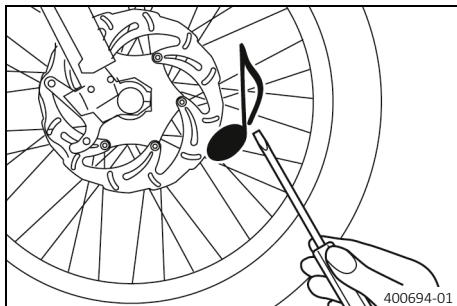

- Strike each spoke briefly using a screwdriver blade.



**Info**

The frequency of the sound depends on the spoke length and spoke diameter.

If spokes of the same length and diameter vibrate with a different tone, this is an indication that the spoke tensions differ.

You should hear a high note.

- » If the spoke tension differs:
  - Correct the spoke tension. 🛠️
- Check the spoke torque.

## Guideline

Spoke nipple	M3.5	3 Nm (2.2 lbf ft)
--------------	------	-------------------

Torque wrench kit (58429094000)
---------------------------------



## 14.1 Cooling system

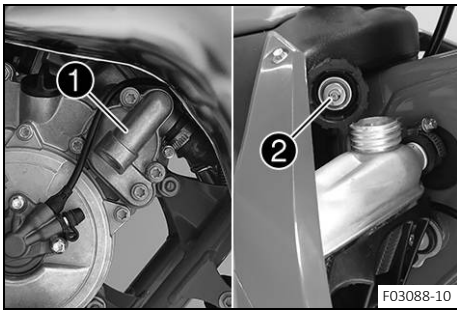

The water pump **1** in the engine forces the coolant to flow. The pressure resulting from the warming of the cooling system is regulated by a valve in the radiator cap **2**. This ensures that operating the vehicle at the specified coolant temperature will not result in a risk of malfunctions.

120 °C (248 °F)

Cooling is effected by the air stream. The lower the speed, the less the cooling effect. Dirty cooling fins also reduce the cooling effect.

## 14.2 Checking the antifreeze and coolant level



### Warning

**Danger of scalding** During motorcycle operation, the coolant gets hot and is under pressure.

- Do not open the radiator, the radiator hoses or other cooling system components if the engine or the cooling system are at operating temperature.
- Allow the cooling system and the engine to cool down before you open the radiator, the radiator hoses or other components of the cooling system.
- In the event of scalding, rinse the area affected immediately with lukewarm water.



### Warning

**Danger of poisoning** Coolant is harmful to health.

- Keep coolant out of the reach of children.
- Do not allow coolant to come into contact with the skin, the eyes and clothing.
- Consult a doctor immediately if coolant is swallowed.
- Rinse the affected area immediately with plenty of water in the event of contact with the skin.
- Rinse eyes thoroughly with water and consult a doctor immediately if coolant gets into the eyes.
- Change clothing if coolant spills onto your clothing.



- Stand the motorcycle upright on a horizontal surface.
- Take off radiator cap **1**.
- Check the antifreeze in the coolant.

-25 ... -45 °C (-13 ... -49 °F)

- » If the antifreeze in the coolant does not match the specified value:
  - Correct the antifreeze in the coolant.

- Check the coolant level in the radiator.

Coolant level <b>A</b> above the radiator fins	10 mm (0.39 in)
--	-----------------

- » If the coolant level does not match the specified value:
  - Correct the coolant level.

Coolant (📖 p. 107)

- Mount the radiator cap.

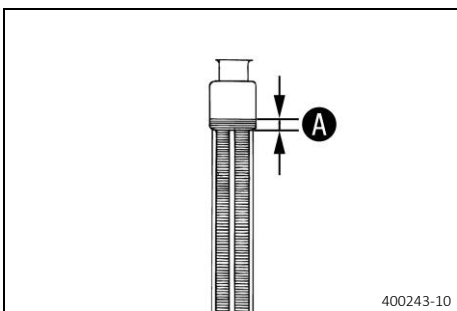

**14.3 Checking the coolant level**



**Warning**

**Danger of scalding** During motorcycle operation, the coolant gets hot and is under pressure.

- Do not open the radiator, the radiator hoses or other cooling system components if the engine or the cooling system are at operating temperature.
- Allow the cooling system and the engine to cool down before you open the radiator, the radiator hoses or other components of the cooling system.
- In the event of scalding, rinse the area affected immediately with lukewarm water.



**Warning**

**Danger of poisoning** Coolant is harmful to health.

- Keep coolant out of the reach of children.
- Do not allow coolant to come into contact with the skin, the eyes and clothing.
- Consult a doctor immediately if coolant is swallowed.
- Rinse the affected area immediately with plenty of water in the event of contact with the skin.
- Rinse eyes thoroughly with water and consult a doctor immediately if coolant gets into the eyes.
- Change clothing if coolant spills onto your clothing.

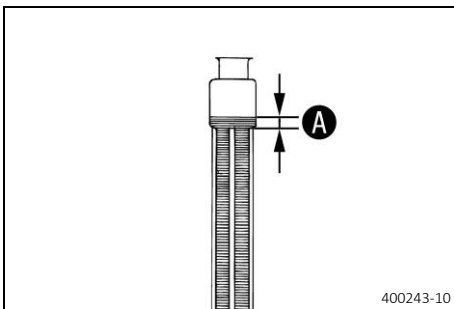

- Stand the motorcycle upright on a horizontal surface.
- Remove the radiator cap.
- Check the coolant level in the radiator.

Coolant level <b>A</b> above the radiator fins	10 mm (0.39 in)
--	-----------------

- » If the coolant level does not match the specified value:
  - Correct the coolant level.

Coolant (📖 p. 107)
--------------------

- Mount the radiator cap.



**14.4 Draining the coolant**



**Warning**

**Danger of scalding** During motorcycle operation, the coolant gets hot and is under pressure.

- Do not open the radiator, the radiator hoses or other cooling system components if the engine or the cooling system are at operating temperature.
- Allow the cooling system and the engine to cool down before you open the radiator, the radiator hoses or other components of the cooling system.
- In the event of scalding, rinse the area affected immediately with lukewarm water.



**Warning**

**Danger of poisoning** Coolant is harmful to health.

- Keep coolant out of the reach of children.
- Do not allow coolant to come into contact with the skin, the eyes and clothing.
- Consult a doctor immediately if coolant is swallowed.
- Rinse the affected area immediately with plenty of water in the event of contact with the skin.
- Rinse eyes thoroughly with water and consult a doctor immediately if coolant gets into the eyes.
- Change clothing if coolant spills onto your clothing.

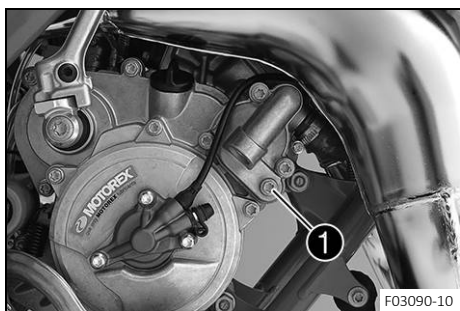

### Condition

The engine is cold.

- Position the motorcycle upright.
- Place an appropriate container under the water pump cover.
- Remove screw **1**. Take off the radiator cap.
- Completely drain the coolant.
- Mount and tighten screw **1** with a new seal ring.

### Guideline

Drain plug, water pump cover	M6	6 Nm (4.4 lbf ft)
------------------------------	----	-------------------

## 14.5 Refilling with coolant



### Warning

**Danger of poisoning** Coolant is harmful to health.

- Keep coolant out of the reach of children.
- Do not allow coolant to come into contact with the skin, the eyes and clothing.
- Consult a doctor immediately if coolant is swallowed.
- Rinse the affected area immediately with plenty of water in the event of contact with the skin.
- Rinse eyes thoroughly with water and consult a doctor immediately if coolant gets into the eyes.
- Change clothing if coolant spills onto your clothing.

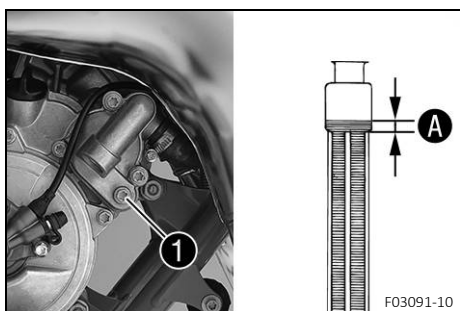

### Main work

- Make sure that screw **1** is tightened.
- Position the motorcycle upright.
- Add coolant to level **A**.

### Guideline

Distance <b>A</b> above the radiator fins	10 mm (0.39 in)
---	-----------------

Coolant	0.55 l (0.58 qt.)	Coolant (📖 p. 107)
---------	-------------------	--------------------

- Move the vehicle into the position shown and prevent it from rolling away. Height difference **B** must be reached.

### Guideline

Height difference <b>B</b>	50 cm (19.7 in)
----------------------------	-----------------

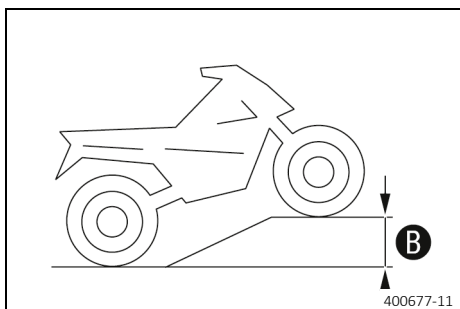

### Info

For all of the air to be able to escape from the cooling system, the vehicle must be raised at the front. If the cooling system is poorly de-aerated, its cooling power will be reduced and the engine may overheat.

- Return the vehicle to the horizontal position.
- Add coolant to level **A**.
- Mount the radiator cap.

### Finishing work

- Go for a short test ride.
- Check the cooling system for leaks.
- Check the coolant level. (📖 p. 83)

14.6 Changing the coolant

**Warning**  
**Danger of scalding** During motorcycle operation, the coolant gets hot and is under pressure.

- Do not open the radiator, the radiator hoses or other cooling system components if the engine or the cooling system are at operating temperature.
- Allow the cooling system and the engine to cool down before you open the radiator, the radiator hoses or other components of the cooling system.
- In the event of scalding, rinse the area affected immediately with lukewarm water.

**Warning**  
**Danger of poisoning** Coolant is harmful to health.

- Keep coolant out of the reach of children.
- Do not allow coolant to come into contact with the skin, the eyes and clothing.
- Consult a doctor immediately if coolant is swallowed.
- Rinse the affected area immediately with plenty of water in the event of contact with the skin.
- Rinse eyes thoroughly with water and consult a doctor immediately if coolant gets into the eyes.
- Change clothing if coolant spills onto your clothing.

**Condition**

The engine is cold.

- Position the motorcycle upright.
- Place an appropriate container under the water pump cover.
- Remove screw ❶. Take off the radiator cap.
- Completely drain the coolant.
- Mount and tighten screw ❶ with a new seal ring.

Guideline

Drain plug, water pump cover	M6	6 Nm (4.4 lbf ft)
------------------------------	----	-------------------

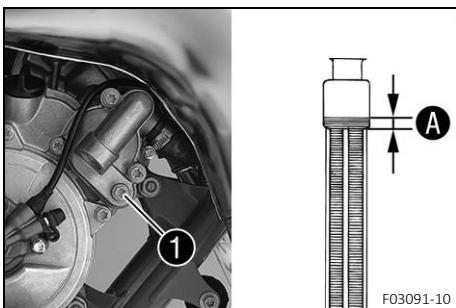
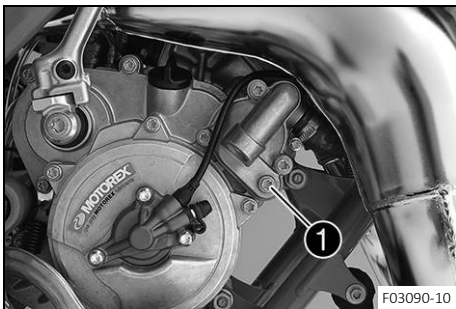

- Make sure that screw ❶ is tightened.
- Add coolant to level A.

Guideline

Distance A above the radiator fins	10 mm (0.39 in)
------------------------------------	-----------------

Coolant	0.55 l (0.58 qt.)	Coolant (📖 p. 107)
---------	-------------------	--------------------

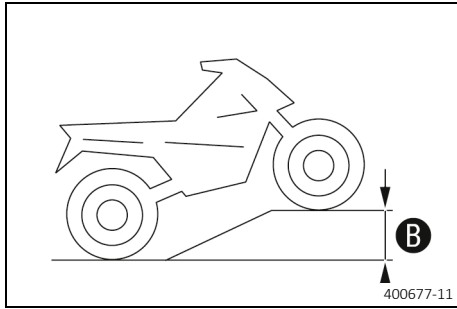

- Move the vehicle into the position shown and secure it against rolling away. Height difference **B** must be reached.

Guideline

Height difference <b>B</b>	50 cm (19.7 in)
----------------------------	-----------------



### Info

For all of the air to be able to escape from the cooling system, the vehicle must be raised at the front. If the cooling system is poorly de-aerated, its cooling power will be reduced and the engine may overheat.

- Return the vehicle to the horizontal position.
- Add coolant to level **A**.
- Mount the radiator cap.

### Finishing work

- Go for a short test ride.
- Check the cooling system for leaks.
- Check the coolant level. (📖 p. 83)



15.1 Checking the play in the throttle cable

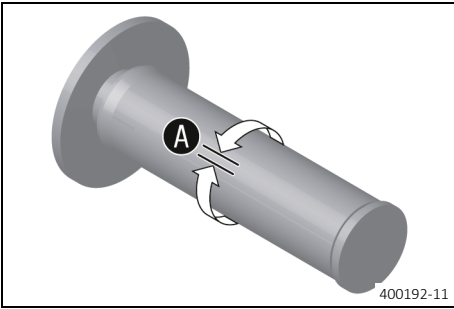

- Check the throttle grip for smooth operation.
- Move the handlebar to the straight-ahead position. Turn the throttle grip back and forth slightly and determine the play in throttle cable **A**.

Play in throttle cable	3 ... 5 mm (0.12 ... 0.2 in)
------------------------	------------------------------

- » If the throttle cable play does not meet the specified value:
  - Adjust the play in the throttle cable. 🛠️ (📖 p. 87)



**Danger**

**Danger of poisoning** Exhaust gases are toxic and inhaling them may result in unconsciousness and death.

- Always make sure there is sufficient ventilation when running the engine.
- Use effective exhaust extraction when starting or running the engine in an enclosed space.

- Start the engine and let it run at idle speed. Move the handlebar to and fro over the entire steering range.

The idle speed must not change.
---------------------------------

- » If the idle speed changes:
  - Adjust the play in the throttle cable. 🛠️ (📖 p. 87)

15.2 Adjusting the play in the throttle cable 🛠️

**Preparatory work**

- Remove the seat. (📖 p. 50)
- Turn the knurled screw on the fuel tap all the way clockwise.
- Remove the fuel tank. 🛠️ (📖 p. 45)
- Check the throttle cable routing. (📖 p. 58)

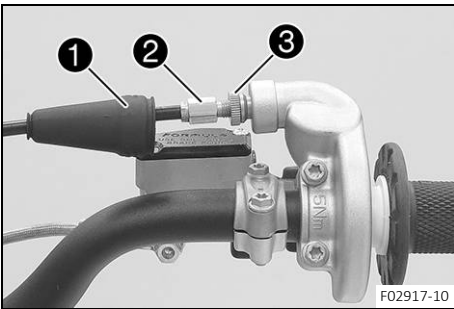

**Main work**

- Move the handlebar to the straight-ahead position.
- Push back sleeve **1**.
- Ensure that the throttle cable sleeve is pushed all the way into barrel adjuster **2**.
- Loosen nut **3**.

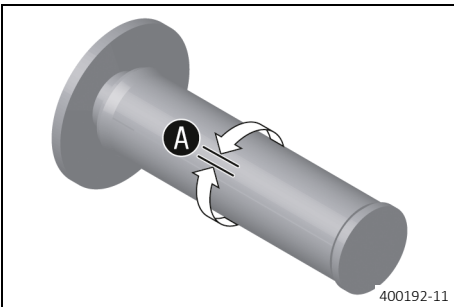

- Turn barrel adjuster **2** so that there is play **A** in the throttle cable at the throttle grip.

Guideline

Play in throttle cable	3 ... 5 mm (0.12 ... 0.2 in)
------------------------	------------------------------

- Tighten nut **3**.
- Slide on sleeve **1**.

## Finishing work

- Install the fuel tank. (🔧 p. 46)
- Mount the seat. (🔧 p. 50)
- Check the play in the throttle cable. (🔧 p. 87)

### 15.3 Carburettor – idle speed

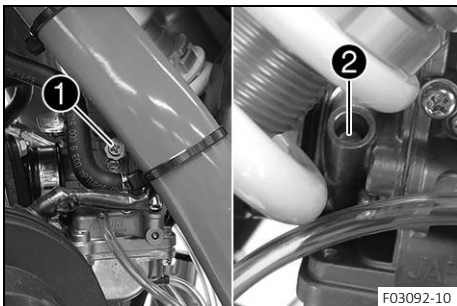

The idle setting of the carburetor has a big influence on the starting behavior, stable idle speed, and the response to throttle opening. This means that an engine with a correctly set idle speed will be easier to start than one with an incorrectly set idle speed.

#### **i** Info

The carburetor and its components are subject to increased wear caused by engine vibration. Wear can result in malfunctioning.

- The idle speed is adjusted using the idle speed adjusting screw **1**.  
The idle mixture is adjusted using the idle air adjusting screw **2**.

### 15.4 Carburetor – adjusting the idle speed 🛠️

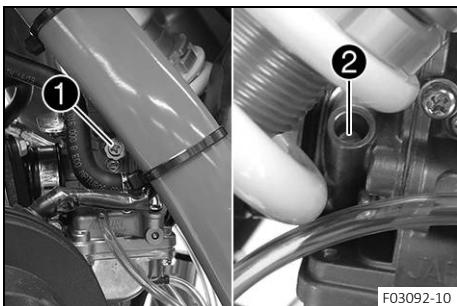

- Screw in idle air adjusting screw **2** all the way and turn it to the specified basic setting.

#### Guideline

Idle air adjusting screw	
Open	3.5 turns

- Run the engine until warm.

#### Guideline

Warming-up phase	≥ 5 min
------------------	---------



#### **Danger**

**Danger of poisoning** Exhaust gases are toxic and inhaling them may result in unconsciousness and death.

- Always make sure there is sufficient ventilation when running the engine.
- Use effective exhaust extraction when starting or running the engine in an enclosed space.

- Adjust the idle speed using idle speed adjusting screw **1**.

#### Guideline

Choke function deactivated – The choke lever is pushed up all the way to the stop. (🔧 p. 16)	
Idle speed	1,400 ... 1,500 rpm

- Turn idle air adjusting screw **2** slowly in a clockwise direction until the idle speed begins to fall.
- Note the position and turn the idle air adjusting screw slowly counterclockwise until the idle speed again begins to fall.
- Adjust to the point between these two positions with the highest idle speed.

**Info**

If there is a big engine speed rise, reduce the idle speed to a normal level and repeat the above steps.

If the procedure described here does not lead to satisfactory results, the cause may be a wrongly dimensioned idling jet.

If you can turn the idle air adjusting screw to the end without any change of engine speed, mount a smaller idling jet.

After changing the idling jet, start from the beginning with the adjusting steps.

Following extreme air temperature or altitude changes, adjust the idle speed again.

**15.5 Emptying the carburetor float chamber****Danger**

**Fire hazard** Fuel is highly flammable.

The fuel in the fuel tank expands when warm and can escape if overfilled.

- Do not fuel the vehicle in the vicinity of open flames or lit cigarettes.
- Switch off the engine for refueling.
- Make sure that no fuel is spilled; particularly not on hot parts of the vehicle.
- If any fuel is spilled, wipe it off immediately.
- Observe the specifications for refueling.

**Warning**

**Danger of poisoning** Fuel is harmful to health.

- Avoid skin, eye and clothing contact with fuel.
- Immediately consult a doctor if you swallow fuel.
- Do not inhale fuel vapors.
- Rinse the affected area immediately with plenty of water in the event of contact with the skin.
- Rinse the eyes thoroughly with water, and consult a doctor in case of fuel contact with the eyes.
- Change your clothing if fuel spills on them.
- Keep fuels correctly in a suitable canister, and out of the reach of children.

**Note**

**Environmental hazard** Improper handling of fuel is a danger to the environment.

- Do not allow fuel to enter the groundwater, the soil, or the sewage system.

**Info**

Carry out work with a cold engine.

Water in the float chamber results in malfunctioning.

**Preparatory work**

- Turn the knurled screw on the fuel tap all the way clockwise.
- ✓ No more fuel flows from the tank to the carburetor.

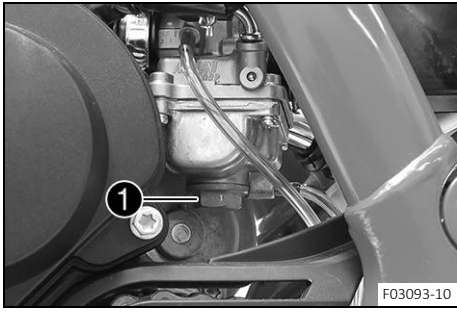

### Main work

- Place a cloth under the carburetor to capture the draining fuel.
- Remove screw plug ①.
- Fully drain the fuel.
- Mount and tighten the screw plug.

**16.1 Checking the gear oil level**

**Condition**

The engine is cold.

**Preparatory work**

- Stand the motorcycle upright on a horizontal surface.

**Main work**

- Remove screw ①.
- Check the gear oil level.

A small quantity of gear oil must run out of the drilled hole.

- » If no gear oil runs out:
  - Add the gear oil. 🛠️ (p. 92)

- Mount and tighten screw ①.

**Guideline**

Screw, gear oil level monitoring	M6	6 Nm (4.4 lbf ft)
----------------------------------	----	-------------------

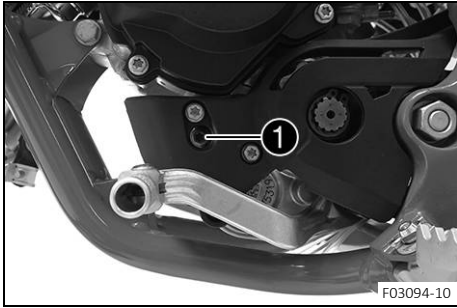

F03094-10

**16.2 Changing the gear oil 🛠️**



**Warning**

**Danger of scalding** Engine and gear oil get hot when the motorcycle is operated.

- Wear suitable protective clothing and safety gloves.
- In the event of scalding, rinse the area affected immediately with lukewarm water.



**Note**

**Environmental hazard** Hazardous substances cause environmental damage.

- Dispose of oils, grease, filters, fuel, cleaning agents, brake fluid, etc., correctly and in compliance with the applicable regulations.



**Info**

Drain gear oil with engine at operating temperature.

**Preparatory work**

- Stand the motorcycle on the plug-in stand on a horizontal surface.

**Main work**

- Position an appropriate container under the engine.
- Remove oil drain plug ① with the magnet.
- Let the gear oil drain fully.
- Thoroughly clean the oil drain plug with magnet.
- Clean the sealing surface on the engine.
- Mount and tighten the oil drain plug with the magnet and new seal ring.

**Guideline**

Oil drain plug with magnet	M12x1.5	20 Nm (14.8 lbf ft)
----------------------------	---------	---------------------

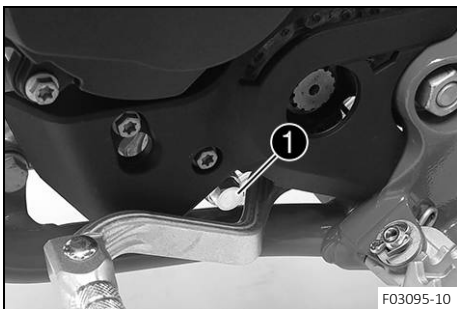

F03095-10

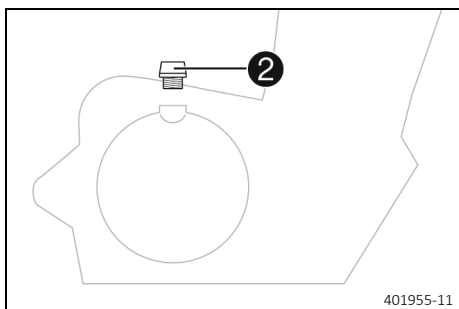

- Remove filler plug **2** with the O-ring, and fill up with gear oil.

Gear oil	0.50 l (0.53 qt.)	Engine oil (15W/50) (📖 p. 107)
----------	-------------------	-----------------------------------

**i Info**  
Too little gear oil or poor-quality gear oil results in premature wear to the transmission.

- Mount and tighten filler plug **2** with the O-ring.

**! Danger**  
**Danger of poisoning** Exhaust gases are toxic and inhaling them may result in unconsciousness and death.

- Always make sure there is sufficient ventilation when running the engine.
- Use effective exhaust extraction when starting or running the engine in an enclosed space.

- Start the engine and check for leaks.

### Finishing work

- Check the gear oil level. (📖 p. 91)

## 16.3 Adding the gear oil 🛠️

**i Info**  
Too little gear oil or poor-quality gear oil results in premature wear to the transmission.

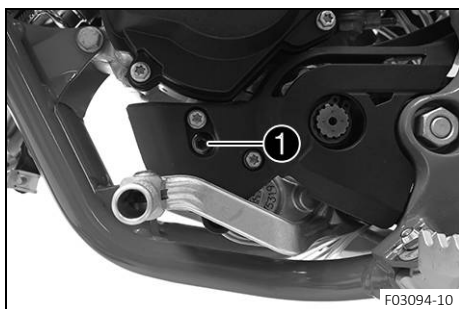

### Preparatory work

- Stand the motorcycle upright on a horizontal surface.

### Main work

- Remove screw **1**.

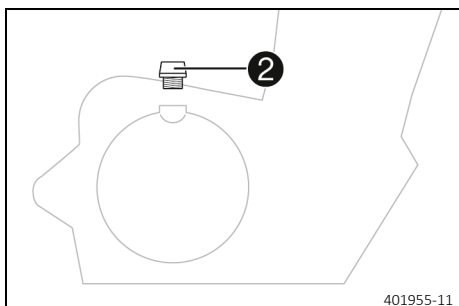

- Remove filler plug **2** with the O-ring.
- Add gear oil until it flows out of the hole of the gear oil level plug.

Engine oil (15W/50) (📖 p. 107)
--------------------------------

- Mount and tighten screw **1**.

### Guideline

Screw, gear oil level monitoring	M6	6 Nm (4.4 lbf ft)
----------------------------------	----	-------------------

- Mount and tighten filler plug **2** with the O-ring.

**Danger**

**Danger of poisoning** Exhaust gases are toxic and inhaling them may result in unconsciousness and death.

- Always make sure there is sufficient ventilation when running the engine.
- Use effective exhaust extraction when starting or running the engine in an enclosed space.

- Start the engine and check for leaks.



## 17.1 Cleaning the motorcycle

### Note

**Material damage** Components become damaged or destroyed if a pressure cleaner is used incorrectly.

The high pressure forces water into the electrical components, connectors, throttle cables, and bearings, etc. Pressure which is too high causes malfunctions and destroys components.

- Do not direct the water jet directly on to electrical components, connectors, throttle cables or bearings.
- Maintain a minimum distance between the nozzle of the pressure cleaner and the component.

Minimum clearance

60 cm (23.6 in)



### Note

**Environmental hazard** Hazardous substances cause environmental damage.

- Dispose of oils, grease, filters, fuel, cleaning agents, brake fluid, etc., correctly and in compliance with the applicable regulations.



### Info

Clean the motorcycle regularly to maintain its value and appearance over a long period. Avoid direct sunshine when cleaning the motorcycle.

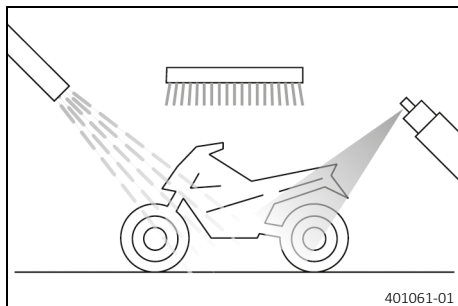

- Close off exhaust system to keep water from entering.
- Remove loose dirt first with a soft jet of water.
- Spray the heavily soiled parts with a normal commercial motorcycle cleaner and clean using a brush.

Motorcycle cleaner (📖 p. 109)



### Info

Use warm water containing normal motorcycle cleaner and a soft sponge. Never apply motorcycle cleaner to a dry vehicle; always rinse the vehicle with water first.

- After rinsing the motorcycle with a gentle spray of water, allow it to dry thoroughly.
- Remove the closure of the exhaust system.
- Empty the carburetor float chamber. 🛠️ (📖 p. 89)



### Warning

**Danger of accidents** Moisture and dirt impair the brake system.

- Explain to your child that he or she must brake carefully several times to dry out and remove dirt from the brake linings and the brake discs.

- After cleaning, your child should ride the vehicle a short distance until the engine warms up and until the brakes system has dried through careful application of the brakes.



### Info

The heat produced causes water at inaccessible locations in the engine and on the brake system to evaporate.

- Push back the protection caps on the handlebar controls to allow water to evaporate.



- After the motorcycle has cooled down, lubricate all moving parts and pivot points.
- Clean the chain. (📖 p. 54)
- Treat bare metal (except for brake discs and the exhaust system) with a corrosion inhibitor.

Preserving materials for paints, metal and rubber (📖 p. 109)

- Treat all plastic parts and powder-coated parts with a mild cleaning and care product.

Special cleaner for glossy and matte paint finishes, metal and plastic surfaces (📖 p. 109)



## 18.1 Storage

**Warning****Danger of poisoning** Fuel is harmful to health.

- Avoid skin, eye and clothing contact with fuel.
- Immediately consult a doctor if you swallow fuel.
- Do not inhale fuel vapors.
- Rinse the affected area immediately with plenty of water in the event of contact with the skin.
- Rinse the eyes thoroughly with water, and consult a doctor in case of fuel contact with the eyes.
- Change your clothing if fuel spills on them.
- Keep fuels correctly in a suitable canister, and out of the reach of children.

**Info**

If the motorcycle is not being used for an extended length of time, additional measures are recommended. Before storing the motorcycle, check all parts for function and wear. If service, repairs, or replacements are necessary, you should do this during the storage period (less workshop overload). This allows you to avoid long waiting periods when the next season starts.

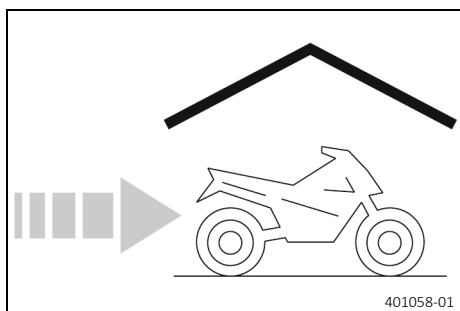

- When refueling for the last time before taking the motorcycle out of service, add fuel additive.

Fuel additive (📖 p. 109)

- Refuel. (📖 p. 24)

**Tip**

Fill the fuel tank completely as specified, using fuel with the lowest possible ethanol content.

- Clean the motorcycle. (📖 p. 94)
- Change the gear oil. 🛠️ (📖 p. 91)
- Check the antifreeze and coolant level. (📖 p. 82)
- Empty the carburetor float chamber. 🛠️ (📖 p. 89)
- Check tire pressure. (📖 p. 80)
- Store the vehicle in a dry location that is not subject to large fluctuations in temperature.

**Info**

GASGAS recommends jacking up the motorcycle.

- Raise the motorcycle with a lift stand. (📖 p. 37)
- Cover the motorcycle with a tarp or cover that is permeable to air.

**Info**

Do not use non-porous materials since they prevent humidity from escaping, thus causing corrosion.

Avoid running the engine for a short time only. Because the engine will not warm up sufficiently, the water vapor produced during combustion will condense, causing engine parts and the exhaust system to rust.

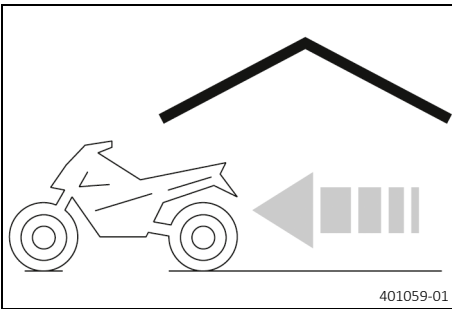
**18.2 Preparing for use after storage**

- Remove the motorcycle from the lift stand. (📖 p. 37)
- Perform checks and maintenance measures when preparing for use. (📖 p. 21)
- Take a test ride.



Faults	Possible cause	Action
Engine turns but does not start	Operating error	– Carry out start procedure. (📖 p. 21)
	Motorcycle was out of use for a long time and there is old fuel in the float chamber	– Empty the carburetor float chamber. 🛠️ (📖 p. 89)
	Fuel supply interrupted	– Check the fuel tank breather. – Clean the fuel tap. – Check/set the carburetor components. 🛠️
	Spark plug sooty or wet	– Clean and dry the spark plug and spark plug connector, or change if necessary.
	Plug gap of spark plug too wide	– Adjust plug gap. Guideline Spark plug electrode gap 0.60 mm (0.0236 in)
	Fault in ignition system	– Check the ignition system. 🛠️ – Adjust the ignition. 🛠️
	Short-circuit cable in wiring harness frayed, stop button faulty	– Check the stop button. 🛠️
	The connector or ignition coil is loose or oxidized	– Clean the plug-in connection and treat it with contact spray.
	Water in carburetor or jets blocked	– Check/set the carburetor components. 🛠️
Engine has no idle speed	Idling jet blocked	– Check/set the carburetor components. 🛠️
	Adjusting screws on carburetor distorted	– Carburetor – adjust the idle speed. 🛠️ (📖 p. 88)
	Spark plug defective	– Change spark plug.
	Ignition system defective	– Check the ignition coil. 🛠️ – Check the spark plug connector. 🛠️
Engine does not speed up	Carburetor running over because float needle dirty or worn	– Check/set the carburetor components. 🛠️
	Loose carburetor jets	– Check/set the carburetor components. 🛠️
	Fault in ignition system	– Check the ignition system. 🛠️ – Adjust the ignition. 🛠️
Engine has too little power	Fuel supply interrupted	– Check the fuel tank breather. – Clean the fuel tap. – Check/set the carburetor components. 🛠️
	Air filter very dirty	– Clean the air filter and air filter box. 🛠️ (📖 p. 51)
	Exhaust system leaky, deformed or too little glass fiber yarn filling in main silencer	– Check exhaust system for damage. – Change the glass fiber yarn filling of the main silencer. 🛠️ (📖 p. 53)
	Fault in ignition system	– Check the ignition system. 🛠️ – Adjust the ignition. 🛠️
	Diaphragm or reed valve housing damaged	– Check the diaphragm and reed valve housing.
	Noticeable wear	– Overhaul the engine.
Engine stalls or is popping into the carburetor	Lack of fuel	– Turn the knurled screw on the fuel tap all the way counterclockwise. – Refuel. (📖 p. 24)
	Engine takes in bad air	– Check the intake flange and carburetor for tightness.

Faults	Possible cause	Action
Engine stalls or is popping into the carburetor	The connector or ignition coil is loose or oxidized	– Clean the plug-in connection and treat it with contact spray.
Engine overheats	Too little coolant in cooling system	– Check the cooling system for leakage. – Check the coolant level. (📖 p. 83)
	Too little air stream	– Switch off engine when standing.
	Radiator fins very dirty	– Clean radiator fins.
	Foam formation in cooling system	– Drain the coolant. 🛠️ (📖 p. 83) – Refill with coolant. 🛠️ (📖 p. 84)
	Damaged cylinder head or cylinder head gasket	– Check the cylinder head or cylinder head gasket.
	Bent radiator hose	– Change the radiator hose. 🛠️
	Incorrect ignition point due to loose stator	– Adjust the ignition. 🛠️
White smoke emission (steam in exhaust gas)	Damaged cylinder head or cylinder head gasket	– Check the cylinder head or cylinder head gasket.
Gear oil exits at the vent hose	Too much gear oil added	– Check the gear oil level. (📖 p. 91)
Water in the gear oil	Damaged radial shaft seal ring or water pump	– Check the radial shaft seal ring and the water pump.

## 20.1 Engine

Design	1-cylinder 2-stroke engine, water-cooled, with reed intake and exhaust control
Displacement	64.85 cm <sup>3</sup> (3.9574 cu in)
Stroke	40.8 mm (1.606 in)
Bore	45 mm (1.77 in)
Idle speed	1,400 ... 1,500 rpm
Control	Exhaust control PCEV (Pneumatic Controlled Exhaust Valve)
Crankshaft bearing	2 grooved ball bearings
Conrod bearing	Needle bearing
Piston pin bearing	Needle bearing
Pistons	Aluminum cast
Piston rings	1 rectangular ring
Engine lubrication	Mixed lubrication
Primary transmission	23:75 straight cut spur gear wheel drive
Clutch	Multidisc clutch in oil bath/hydraulically activated
Gearbox	6-gear transmission, claw shifted
Transmission ratio	
1st gear	13:37
2nd gear	16:34
3rd gear	18:31
4th gear	21:30
5th gear	23:28
6th gear	24:26
Ignition	Non-contact controlled fully electronic ignition system with digital ignition adjustment
Spark plug	NGK LR 8 B
Spark plug electrode gap	0.60 mm (0.0236 in)
Cooling	Water-cooled
Starting aid	Kick starter lever

## 20.2 Engine tightening torques

Lower part of control valve	M4	4 Nm (3 lbf ft)	<b>Loctite® 648™</b>
Nut, exhaust control diaphragm	M5	4 Nm (3 lbf ft)	
Screw, clutch line holder	M5	5 Nm (3.7 lbf ft)	
Screw, diaphragm cover of exhaust control	M5	4 Nm (3 lbf ft)	
Screw, ignition system/stator	M5	5 Nm (3.7 lbf ft)	<b>Loctite® 222™</b>
Screw, main shaft bearing retainer	M5	6 Nm (4.4 lbf ft)	<b>Loctite® 243™</b>
Screw, reed valve housing of exhaust control	M5	5 Nm (3.7 lbf ft)	
Screw, retaining bracket for return spring of shift shaft	M5	6 Nm (4.4 lbf ft)	<b>Loctite® 243™</b>

Screw, shift drum locating	M5	6 Nm (4.4 lbf ft) <b>Loctite®243™</b>
Screw, water pump impeller	M5	2 Nm (1.5 lbf ft) <b>Loctite®243™</b>
Drain plug, water pump cover	M6	6 Nm (4.4 lbf ft)
Screw, alternator cover	M6	8 Nm (5.9 lbf ft)
Screw, clutch cover	M6	10 Nm (7.4 lbf ft)
Screw, clutch slave cylinder	M6	8 Nm (5.9 lbf ft) <b>Loctite®243™</b>
Screw, clutch springs	M6	10 Nm (7.4 lbf ft)
Screw, engine case	M6	10 Nm (7.4 lbf ft)
Screw, engine sprocket cover	M6	10 Nm (7.4 lbf ft)
Screw, exhaust flange	M6	10 Nm (7.4 lbf ft) <b>Loctite®243™</b>
Screw, gear oil level monitoring	M6	6 Nm (4.4 lbf ft)
Screw, intake flange	M6	6 Nm (4.4 lbf ft)
Screw, kick starter lever stop piece	M6	10 Nm (7.4 lbf ft) <b>Loctite®243™</b>
Screw, outer clutch cover	M6	10 Nm (7.4 lbf ft)
Screw, reed valve housing of exhaust control	M6	10 Nm (7.4 lbf ft)
Screw, shift drum bearing retainer	M6	5 Nm (3.7 lbf ft) <b>Loctite®243™</b>
Screw, shift drum locating	M6	10 Nm (7.4 lbf ft) <b>Loctite®243™</b>
Screw, shift lever	M6	14 Nm (10.3 lbf ft) <b>Loctite®243™</b>
Screw, water pump cover	M6	8 Nm (5.9 lbf ft)
Vacuum connection/vent connection	M6	4 Nm (3 lbf ft) <b>Loctite®243™</b>
Screw, cylinder head	M7	18 Nm (13.3 lbf ft)
Nuts, cylinder base	M8	20 Nm (14.8 lbf ft)
Screw, kick starter lever	M8	20 Nm (14.8 lbf ft) <b>Loctite®243™</b>
Stud, cylinder base (left section of the engine case)	M8	Tightening sequence: Screw in up to 27 mm projection <b>Loctite®243™</b>
Stud, cylinder base (right section of the engine case)	M8	Tightening sequence: Screw in up to 29 mm projection <b>Loctite®243™</b>
Screw, inner clutch hub	M10	60 Nm (44.3 lbf ft) <b>Loctite®243™</b>
Spark plug	M10x1	10 ... 12 Nm (7.4 ... 8.9 lbf ft)
Nut, rotor	M12x1	50 Nm (36.9 lbf ft)
Oil drain plug with magnet	M12x1.5	20 Nm (14.8 lbf ft)
Nut, primary gear wheel	M14x1.25	40 Nm (29.5 lbf ft) <b>Loctite®243™</b>

## 20.3 Carburetor

Carburetor type	MIKUNI TM 24
Needle position	2nd position from top
Idle air adjusting screw	
Open	3.5 turns
Main jet	210
Jet needle	5N17
Idling jet	20
Needle jet	Q-O (454)
Throttle slide	2.5

### 20.3.1 Carburetor tuning

#### MIKUNI TM 24

ASL	TEMP	-20 ... -7 °C (-4 ... 19 °F)	-6 ... 5 °C (21 ... 41 °F)	6 ... 15 °C (43 ... 59 °F)	16 ... 24 °C (61 ... 75 °F)	25 ... 36 °C (77 ... 97 °F)	37 ... 49 °C (99 ... 120 °F)
2,301 ... 3,000 m (7,549 ... 9,843 ft)	ASO IJ NDL POS MJ	3.5 20 5N17 3 210	3.5 20 5N17 2 210	3.5 15 5N17 2 205	3.5 15 5N17 2 200	2.5 15 5N17 1 200	
1,501 ... 2,300 m (4,925 ... 7,546 ft)	ASO IJ NDL POS MJ	3.5 20 5N17 3 210	3.5 20 5N17 2 210	3.5 20 5N17 2 210	3.5 15 5N17 2 205	3.5 15 5N17 2 200	2.5 15 5N17 1 200
751 ... 1,500 m (2,464 ... 4,921 ft)	ASO IJ NDL POS MJ	3 25 5N17 3 215	3.5 20 5N17 3 210	3.5 20 5N17 2 210	3.5 20 5N17 2 210	3.5 15 5N17 2 205	3.5 15 5N17 2 200
301 ... 750 m (988 ... 2,461 ft)	ASO IJ NDL POS MJ	3 30 5N17 3 220	3 25 5N17 3 215	3.5 20 5N17 3 210	<b>3,5</b> <b>20</b> <b>5N17</b> <b>2</b> <b>210</b>	3.5 20 5N17 2 210	3.5 15 5N17 2 205
0 ... 300 m (0 ... 984 ft)	ASO IJ NDL POS MJ	3 30 5N17 3 225	3 25 5N17 3 215	3.5 20 5N17 3 210	3.5 20 5N17 2 210	3.5 20 5N17 2 210	3.5 15 5N17 2 205

ASL	Above sea level
TEMP	Temperature
ASO	Open (rotations) idle air adjusting screw
IJ	Idling jet
NDL	Jet needle
POS	Needle position from top
MJ	Main jet

The carburetor tuning depends on the defined ambient and operating conditions.



**20.4 Capacities**
**20.4.1 Gear oil**

Gear oil	0.50 l (0.53 qt.)	Engine oil (15W/50) (📖 p. 107)
----------	-------------------	--------------------------------

**20.4.2 Coolant**

Coolant	0.55 l (0.58 qt.)	Coolant (📖 p. 107)
---------	-------------------	--------------------

**20.4.3 Fuel**

Fuel tank capacity, approx.	3.5 l (3.7 qt.)	Super unleaded (95 octane) mixed with 2-stroke engine oil (1:60) (📖 p. 108)
-----------------------------	-----------------	---

**20.5 Fork**

Fork article number	07.18.6U.03	
Fork	<b>WP XACT 5235</b>	
Rebound damping		
Comfort	15 clicks	
Standard	12 clicks	
Sport	10 clicks	
Air pressure	3 bar (44 psi)	
Fork length	735 mm (28.94 in)	
Spring length with preload spacer(s)	377.5 mm (14.862 in)	

Oil capacity external mechanism left	40 ± <sup>15</sup> / <sub>10</sub> ml (1.35 ± <sup>0.51</sup> / <sub>0.34</sub> fl. oz.)	Fork oil (SAE 4) (48601166S1) (📖 p. 108)
Oil capacity, right cartridge	240 ml (8.11 fl. oz.)	Fork oil (SAE 4) (48601166S1) (📖 p. 108)
Grease capacity, left cartridge	6 g (0.21 oz)	Special grease (00062010053) (📖 p. 110)

**20.6 Shock absorber**

Shock absorber article number	03.18.7T.03	
Shock absorber	<b>WP XACT 5735</b>	
Low-speed compression damping		
Comfort	18 clicks	
Standard	15 clicks	
Sport	12 clicks	
High-speed compression damping		
Comfort	2.5 turns	
Standard	2 turns	
Sport	1.5 turns	
Rebound damping		
Comfort	18 clicks	
Standard	15 clicks	
Sport	12 clicks	
Spring preload	5 mm (0.2 in)	
Spring rate		

Weight of rider: 35 kg (77 lb.)	35 N/mm (200 lb/in)
Weight of rider: 40 kg (88 lb.)	40 N/mm (228 lb/in)
Weight of rider: 45 kg (99 lb.)	45 N/mm (257 lb/in)
Spring length	210 mm (8.27 in)
Gas pressure	10 bar (145 psi)
Static sag	30 mm (1.18 in)
Rider sag	70 mm (2.76 in)
Fitted length	347 mm (13.66 in)
Shock absorber fluid (🔧 p. 108)	SAE 2.5

## 20.7 Chassis

Frame	Central tube frame of chrome molybdenum steel tubing, powder-coated
Fork	<b>WP XACT 5235</b>
Shock absorber	<b>WP XACT 5735</b>
Suspension travel	
front	215 mm (8.46 in)
rear	270 mm (10.63 in)
Fork offset	22 mm (0.87 in)
Brake system	
front	Disc brake with 4-piston brake caliper
rear	Disc brake with 4-piston brake caliper
Brake disc diameters	
front	198 mm (7.8 in)
rear	160 mm (6.3 in)
Brake discs - wear limits	
front	2.5 mm (0.098 in)
rear	2.5 mm (0.098 in)
Offroad tire pressure	
front	1.0 bar (15 psi)
rear	1.0 bar (15 psi)
Secondary drive ratio	14:48
Chain	1/2 x 1/4" O-ring
Rear sprockets available	46, 48, 50
Steering head angle	64.5°
Wheelbase	1,137 mm (44.76 in)
Seat height unloaded	750 mm (29.53 in)
Ground clearance unloaded	280 mm (11.02 in)
Weight without fuel approx.	53 kg (117 lb.)
Maximum rider weight	50 kg (110 lb.)

**20.8 Tires**

Front tire	Rear tire
<b>60/100 - 14 M/C 30M TT</b> MAXXIS MAXX CROSS SI	<b>80/100 - 12 41M TT</b> MAXXIS MAXX CROSS SI
The tires specified represent one of the possible series production tires. For alternative manufacturers, if any, contact an authorized dealer or qualified tire dealership. If local road approval regulations apply, these and the respective technical specifications must be observed. Additional information is available in the Service section under: <a href="http://www.gasgas.com">http://www.gasgas.com</a>	

**20.9 Chassis tightening torques**

Hose clip, carburetor	-	2.8 Nm (2.07 lbf ft)
Screw, brake hose bracket	<b>EJOT</b>	1.7 Nm (1.25 lbf ft)
Stop button screw	M3	0.4 Nm (0.3 lbf ft)
Spoke nipple	M3.5	3 Nm (2.2 lbf ft)
Screw, throttle slide cover	M4	2 Nm (1.5 lbf ft)
Remaining nuts, chassis	M5	5 Nm (3.7 lbf ft)
Remaining screws, chassis	M5	5 Nm (3.7 lbf ft)
Nut, push rod, foot brake lever	M6	6 Nm (4.4 lbf ft)
Remaining nuts, chassis	M6	10 Nm (7.4 lbf ft)
Remaining screws, chassis	M6	10 Nm (7.4 lbf ft)
Screw, ball joint of push rod on brake cylinder	M6	10 Nm (7.4 lbf ft) <b>Loctite®243™</b>
Screw, brake cylinder	M6	10 Nm (7.4 lbf ft)
Screw, brake cylinder	M6	5 Nm (3.7 lbf ft)
Screw, clutch master cylinder	M6	5 Nm (3.7 lbf ft)
Screw, fender	M6	6 Nm (4.4 lbf ft)
Screw, fork stub	M6	10 Nm (7.4 lbf ft)
Screw, front brake disc	M6	14 Nm (10.3 lbf ft) <b>Loctite®243™</b>
Screw, front brake linings	M6	10 Nm (7.4 lbf ft)
Screw, fuel tank spoiler on radiator	M6	6 Nm (4.4 lbf ft)
Screw, rear brake disc	M6	14 Nm (10.3 lbf ft) <b>Loctite®243™</b>
Screw, rear brake lining	M6	10 Nm (7.4 lbf ft)
Screw, throttle grip	M6	4.5 Nm (3.32 lbf ft)
Start number plate screw	M6	4 Nm (3 lbf ft)
Brake lever stop nut	M8	20 Nm (14.8 lbf ft)
Fitting, engine mounting bracket	M8	30 Nm (22.1 lbf ft)
Nut, rim lock	M8	10 Nm (7.4 lbf ft)
Remaining nuts, chassis	M8	25 Nm (18.4 lbf ft)
Remaining screws, chassis	M8	25 Nm (18.4 lbf ft)
Screw, bottom triple clamp	M8	15 Nm (11.1 lbf ft)
Screw, chain sliding piece	M8	15 Nm (11.1 lbf ft)
Screw, engine bracket	M8	30 Nm (22.1 lbf ft) <b>Loctite®2701™</b>
Screw, engine sprocket cover	M8	15 Nm (11.1 lbf ft)

## 20 TECHNICAL SPECIFICATIONS

Screw, front brake caliper	M8	20 Nm (14.8 lbf ft) <b>Loctite®243™</b>
Screw, handlebar clamp	M8	20 Nm (14.8 lbf ft)
Screw, rear brake caliper	M8x20	18 Nm (13.3 lbf ft) <b>Loctite®243™</b>
Screw, rear brake caliper	M8x40	18 Nm (13.3 lbf ft) <b>Loctite®243™</b>
Screw, rear sprocket	M8	25 Nm (18.4 lbf ft) <b>Loctite®243™</b>
Screw, steering stem	M8	20 Nm (14.8 lbf ft)
Screw, subframe	M8	35 Nm (25.8 lbf ft) <b>Loctite®2701™</b>
Screw, top triple clamp	M8	20 Nm (14.8 lbf ft)
Remaining nuts, chassis	M10	45 Nm (33.2 lbf ft)
Remaining screws, chassis	M10	45 Nm (33.2 lbf ft)
Screw, bottom shock absorber	M10	45 Nm (33.2 lbf ft) <b>Loctite®243™</b>
Screw, foot brake lever	M10	35 Nm (25.8 lbf ft) <b>Loctite®243™</b>
Screw, front wheel spindle	M10	40 Nm (29.5 lbf ft) <b>Loctite®243™</b>
Screw, handlebar support	M10	40 Nm (29.5 lbf ft) <b>Loctite®243™</b>
Screw, top shock absorber	M10	45 Nm (33.2 lbf ft) <b>Loctite®243™</b>
Nut, swingarm pivot	M12x1	40 Nm (29.5 lbf ft)
Nut, rear wheel spindle	M14x1.5	40 Nm (29.5 lbf ft)
Nut, steering head	M20x1.5	10 Nm (7.4 lbf ft)

**Brake fluid DOT 4 / DOT 5.1****Standard/classification**

- DOT

**Guideline**

- Use only brake fluid that complies with the specified standard (see specifications on the container) and that exhibits the corresponding properties.

**Recommended supplier****Castrol**

- REACT PERFORMANCE DOT 4

**MOTOREX®**

- Brake Fluid DOT 5.1

**Coolant****Guideline**

- Only use high-grade, silicate-free coolant with corrosion inhibitor additive for aluminum motors. Low grade and unsuitable antifreeze causes corrosion, deposits and frothing.
- Do not use pure water as only coolant is able to meet the requirements needed in terms of corrosion protection and lubrication properties.
- Only use coolant that complies with the requirements stated (see specifications on the container) and that has the relevant properties.

Antifreeze protection to at least	-25 °C (-13 °F)
-----------------------------------	-----------------

The mixture ratio must be adjusted to the necessary antifreeze protection. Use distilled water if the coolant needs to be diluted.

The use of premixed coolant is recommended.

Observe the coolant manufacturer specifications for antifreeze protection, dilution and miscibility (compatibility) with other coolants.

**Recommended supplier****MOTOREX®**

- COOLANT M3.0

**Engine oil (15W/50)****Standard/classification**

- JASO T903 MA2 (📖 p. 111)
- SAE (📖 p. 111) (15W/50)

**Guideline**

- Use only engine oils that comply with the specified standards (see specifications on the container) and that possess the corresponding properties.

**Recommended supplier****MOTOREX®**

- Top Speed 4T

**Engine oil, 2-stroke****Standard/classification**

- JASO FD (📖 p. 111)

**Guideline**

- Only use high-grade 2-stroke engine oil from a reputable brand.

fully synthetic
-----------------

**Recommended supplier****MOTOREX®**

- Cross Power 2T

## Fork oil (SAE 4) (48601166S1)

### Standard/classification

- SAE (📖 p. 111) (SAE 4)

### Guideline

- Use only oils that comply with the specified standards (see specifications on the container) and that exhibit the corresponding properties.

## Shock absorber fluid (SAE 2.5) (50180751S1)

### Standard/classification

- SAE (📖 p. 111) (SAE 2.5)

### Guideline

- Use only oils that comply with the specified standards (see specifications on the container) and that exhibit the corresponding properties.

## Super unleaded (ROZ 95)

### Standard/classification

- DIN EN 228 (ROZ 95)

### Guideline

- Only use super unleaded fuel that matches or is equivalent to the specified standard.
- Fuel with an ethanol content of up to 10% (E10 fuel) is safe to use.



### Info

Do **not** use fuel containing methanol (e.g., M15, M85, M100) or more than 10% ethanol (e.g., E15, E25, E85, E100).

## Super unleaded (95 octane) mixed with 2-stroke engine oil (1:60)

### Standard/classification

- DIN EN 228
- JASO FD (📖 p. 111) (1:60)

### Mixture ratio

1:60	Engine oil, 2-stroke (📖 p. 107) Super unleaded (ROZ 95) (📖 p. 108)
------	---

### Recommended supplier

**MOTOREX®**

- Cross Power 2T

**Air filter cleaner**

Recommended supplier

MOTOREX®

- Racing Bio Dirt Remover

**Chain cleaner**

Recommended supplier

MOTOREX®

- Chain Clean

**Fuel additive**

Recommended supplier

MOTOREX®

- Fuel Stabilizer

**High viscosity grease**

Recommended supplier

SKF®

- LGHB 2

**Long-life grease**

Recommended supplier

MOTOREX®

- Bike Grease 2000

**Motorcycle cleaner**

Recommended supplier

MOTOREX®

- Moto Clean

**Off-road chain spray**

Recommended supplier

MOTOREX®

- Chainlube Offroad

**Oil for foam air filter**

Recommended supplier

MOTOREX®

- Racing Bio Liquid Power

**Preserving materials for paints, metal and rubber**

Recommended supplier

MOTOREX®

- Moto Protect

**Special cleaner for glossy and matte paint finishes, metal and plastic surfaces**

Recommended supplier

MOTOREX®

- Quick Cleaner

### Special grease (00062010053)

Recommended supplier

Klüber Lubrication®

- Klüberfood NH1 34-401

### Universal oil spray

Recommended supplier

MOTOREX®

- Joker 440 Synthetic



### JASO T903 MA2

Different technical development directions required a separate specification for motorcycles – the **JASO T903 MA2** standard.

Earlier, engine oils from the automobile industry were used for motorcycles because there was no separate motorcycle specification.

Whereas long service intervals are demanded for automobile engines, the focus for motorcycle engines is on high performance at high engine speeds.

In most motorcycle engines, the transmission and clutch are lubricated with the same oil.

The **JASO T903 MA2** standard meets these special requirements.

### SAE

The SAE viscosity classes were defined by the Society of Automotive Engineers and are used for classifying oils according to their viscosity. The viscosity describes only one property of oil and says nothing about quality.

### JASO FD

JASO FD is a classification for a 2-stroke engine oil that was specifically developed for the extreme demands of racing.

Thanks to first-rate synthetic esters and specially designed additives, superb combustion is achieved even under extreme operating conditions.

## 24 LIST OF ABBREVIATIONS

Art. no.	Article number
ca.	circa
cf.	compare
e.g.	for example
etc.	et cetera
i.a.	inter alia
no.	number
poss.	possibly

<b>A</b>	
<b>Accessories</b>	9
<b>Air filter</b>	
cleaning	51
installing	51
removing	50
<b>Air filter box</b>	
cleaning	51
<b>Air suspension</b>	28
<b>Antifreeze</b>	
checking	82
<b>Auxiliary substances</b>	9
<b>B</b>	
<b>Basic chassis setting</b>	
with rider's weight, checking	28
<b>Brake discs</b>	
checking	63
<b>Brake fluid</b>	
adding front brake	64
adding to rear brake	71
<b>Brake fluid level</b>	
of front brake, checking	64
of rear brake, checking	71
<b>Brake lining retainers</b>	
of front brake, checking	66
of rear brake, checking	73
<b>Brake linings</b>	
of front brake, checking	66
of rear brake, checking	73
of the front brake, changing	66
of the rear brake, changing	73
<b>C</b>	
<b>Capacity</b>	
coolant	84-85, 103
fuel	25, 103
gear oil	92, 103
<b>Carburetor</b>	
adjusting the idle speed	88
float chamber, emptying	89
idle speed	88
<b>Chain</b>	
checking	56
cleaning	54
<b>Chain guide</b>	
checking	56
<b>Chain tension</b>	
adjusting	55
checking	54
<b>Choke</b>	16
<b>Cleaning</b>	94-95

<b>Clutch</b>	
changing fluid	61
correcting fluid level	60
fluid level, checking	60
<b>Clutch lever</b>	14
basic position, adjusting	59
<b>Coolant</b>	
changing	85
draining	83
refilling	84
<b>Coolant level</b>	
checking	82-83
<b>Cooling system</b>	82
<b>Customer service</b>	9
<b>E</b>	
<b>Engine</b>	
running in	19
<b>Engine number</b>	12
<b>Engine sprocket</b>	
checking	56
<b>Environment</b>	8
<b>F</b>	
<b>Figures</b>	9
<b>Foot brake lever</b>	17
basic position, adjusting	70
free travel, adjusting	69
free travel, checking	69
<b>Fork article number</b>	12
<b>Fork legs</b>	
air pressure, adjusting	34
bleeding	37
checking basic setting	34
dust boots, cleaning	38
installing	40
removing	40
<b>Fork protector</b>	
installing	39
removing	39
<b>Frame</b>	
checking	58
<b>Front fender</b>	
installing	48
removing	48
<b>Front wheel</b>	
installing	76
removing	76
<b>Fuel tank</b>	
installing	46
removing	45
<b>Fuel tank filler cap</b>	
closing	15
opening	15

<b>Fuel tap</b> .....	16	after storage .....	97
<b>Fuel, oils, etc.</b> .....	9	checks and maintenance measures when preparing for use .....	21
<b>G</b>			
<b>Gear oil</b>		<b>Protective clothing</b> .....	7
adding .....	92	<b>R</b>	
changing .....	91	<b>Rear sprocket</b>	
<b>Gear oil level</b>		checking .....	56
checking .....	91	<b>Rear wheel</b>	
<b>H</b>			
<b>Hand brake lever</b> .....	14	installing .....	78
basic position, adjusting .....	63	removing .....	77
free travel, checking .....	63	<b>Rebound damping</b>	
<b>Handlebar position</b> .....	36	fork, adjusting .....	35
adjusting .....	36	shock absorber, adjusting .....	30
<b>High-speed compression damping</b>		<b>Refueling</b>	
shock absorber, adjusting .....	29	fuel .....	24
<b>I</b>			
<b>Implied warranty</b> .....	9	<b>Riding sag</b>	
<b>Intended use</b> .....	6	adjusting .....	33
<b>K</b>			
<b>Kick starter lever</b> .....	17	<b>Rubber grip</b>	
<b>L</b>			
<b>Link fork</b>		checking .....	59
checking .....	58	securing .....	59
<b>Lower triple clamp</b>		<b>S</b>	
installing .....	42	<b>Safe operation</b> .....	7
removing .....	41	<b>Seat</b>	
<b>Lowspeed compression damping</b>		mounting .....	50
shock absorber, adjusting .....	29	removing .....	50
<b>M</b>			
<b>Main silencer</b>		<b>Service</b> .....	9
glass fiber yarn filling, changing .....	53	<b>Service schedule</b> .....	26-27
installing .....	52	<b>Shift lever</b> .....	16
removing .....	52	<b>Shock absorber</b>	
<b>Manufacturer warranty</b> .....	9	installing .....	49
<b>Misuse</b> .....	6	removing .....	49
<b>Motorcycle</b>		riding sag, checking .....	32
cleaning .....	94	spring preload, adjusting .....	32
from lift stand, removing .....	37	static sag, checking .....	31
raising with lift stand .....	37	<b>Shock absorber article number</b> .....	13
<b>O</b>			
<b>Owner's Manual</b> .....	8	<b>Spare parts</b> .....	9
<b>P</b>			
<b>Play in throttle cable</b>		<b>Spoke tension</b>	
adjusting .....	87	checking .....	80
checking .....	87	<b>Start number plate</b>	
<b>Plug-in stand</b> .....	17	installing .....	48
<b>Preparing for use</b>		removing .....	47
advice on preparing for first use .....	18	<b>Starting</b> .....	21
		<b>Steering head bearing</b>	
		lubricating .....	45
		<b>Steering head bearing play</b>	
		adjusting .....	44
		checking .....	44
		<b>Stop button</b> .....	14
		<b>Storage</b> .....	96

**T****Technical specifications**

capacities . . . . .	103
carburetor . . . . .	102
chassis . . . . .	104
chassis tightening torques . . . . .	105
engine . . . . .	100
engine tightening torques . . . . .	100
fork . . . . .	103
shock absorber . . . . .	103
tires . . . . .	105

**Throttle cable routing**

checking . . . . .	58
--------------------	----

**Throttle grip . . . . . 14****Tire condition**

checking . . . . .	79
--------------------	----

**Tire pressure**

checking . . . . .	80
--------------------	----

**Transporting . . . . . 24****Troubleshooting . . . . . 98-99****Type label . . . . . 12****U****Use definition . . . . . 6****V****Vehicle identification number . . . . . 12****View of vehicle**

front left . . . . .	10
rear right . . . . .	11

**W****Work rules . . . . . 8**



3215006en

08/2020



Stallhofnerstraße 3 / 5230 Mattighofen / Austria / <http://www.gasgas.com>

