

PIONEERING SINCE 1903

# OWNER'S MANUAL 2017



TC 50

Art. no. 3402091en



**Husqvarna**<sup>®</sup>  
MOTORCYCLES



# DEAR HUSQVARNA MOTORCYCLES CUSTOMER

Congratulations on your decision to purchase a Husqvarna motorcycle. You are now the owner of a state-of-the-art sports motorcycle that will give you and your child enormous pleasure if you service and maintain it accordingly.

We hope you enjoy your new vehicle!

Enter the serial numbers of your vehicle below.

Chassis number (📖 p. 10)	Dealer's stamp
Engine number (📖 p. 10)	

The Owner's Manual contained the latest information for this model series at the time of going to print. However, minor differences due to developments in design cannot be ruled out completely.

All specifications are non-binding. Husqvarna Motorcycles GmbH specifically reserves the right to modify or delete technical specifications, prices, colors, forms, materials, services, designs, equipment, etc., without prior notice and without specifying reasons, to adapt these to local conditions, as well as to stop production of a particular model without prior notice. Husqvarna Motorcycles accepts no liability for delivery options, deviations from illustrations and descriptions, as well as misprints and other errors. The models portrayed partly contain special equipment that does not belong to the regular scope of supply.

© 2016 Husqvarna Motorcycles GmbH, Mattighofen Austria

All rights reserved

Reproduction, even in part, as well as copying of all kinds, is permitted only with the express written permission of the copyright owner.



ISO 9001(12 100 6061)

Husqvarna Motorcycles applies quality assurance processes that lead to the highest possible product quality as defined in the ISO 9001 international quality management standard.

Issued by: TÜV Management Service

REG.NO. 12 100 6061

Husqvarna Motorcycles GmbH  
5230 Mattighofen, Austria



























This document is valid for the following models:

TC 50 (F2001Q4)



# TABLE OF CONTENTS







1	MEANS OF REPRESENTATION.....	4	10	TUNING THE CHASSIS.....	22
1.1	Symbols used .....	4	10.1	Checking the basic chassis setting with the rider's weight .....	22
1.2	Formats used .....	4	10.2	Air suspension AER 35 .....	22
2	SAFETY ADVICE .....	5	10.3	Compression damping of the shock absorber ...	22
2.1	Use definition – intended use .....	5	10.4	Adjusting the low-speed compression damping of the shock absorber.....	23
2.2	Safety advice .....	5	10.5	Adjusting the high-speed compression damping of the shock absorber.....	23
2.3	Degrees of risk and symbols .....	5	10.6	Adjusting the rebound damping of the shock absorber.....	24
2.4	Tampering warning .....	5	10.7	Measuring rear wheel sag unloaded.....	24
2.5	Safe operation.....	5	10.8	Checking the static sag of the shock absorber.....	24
2.6	Protective clothing.....	6	10.9	Checking the riding sag of the shock absorber.....	25
2.7	Work rules.....	6	10.10	Adjusting the spring preload of the shock absorber 🛠.....	25
2.8	Environment.....	6	10.11	Adjusting the riding sag 🛠.....	26
2.9	Owner's Manual.....	6	10.12	Checking the basic setting of the fork.....	26
3	IMPORTANT NOTES .....	7	10.13	Adjusting the fork air pressure.....	26
3.1	Manufacturer and implied warranty .....	7	10.14	Adjusting the rebound damping of the fork .....	27
3.2	Operating and auxiliary substances .....	7	10.15	Handlebar position.....	28
3.3	Spare parts, accessories .....	7	10.16	Adjusting the handlebar position 🛠.....	28
3.4	Service .....	7	10.17	Adjusting the seat height 🛠.....	28
3.5	Figures .....	7	11	SERVICE WORK ON THE CHASSIS .....	30
3.6	Customer service.....	7	11.1	Raising the motorcycle with a lift stand.....	30
4	VIEW OF VEHICLE .....	8	11.2	Removing the motorcycle from the lift stand.....	30
4.1	View of vehicle, front left (example).....	8	11.3	Bleeding the fork legs .....	30
4.2	View of vehicle, rear right (example).....	9	11.4	Cleaning the dust boots of the fork legs.....	31
5	SERIAL NUMBERS.....	10	11.5	Removing the fork protector.....	31
5.1	Chassis number .....	10	11.6	Installing the fork protector.....	31
5.2	Type label.....	10	11.7	Removing the fork legs 🛠.....	32
5.3	Engine number.....	10	11.8	Installing the fork legs 🛠.....	32
5.4	Fork part number .....	10	11.9	Removing the lower triple clamp 🛠.....	33
5.5	Shock absorber article number .....	10	11.10	Installing the lower triple clamp 🛠.....	34
6	CONTROLS.....	11	11.11	Checking play of steering head bearing .....	35
6.1	Hand brake lever.....	11	11.12	Adjusting the steering head bearing play 🛠.....	36
6.2	Throttle grip.....	11	11.13	Greasing the steering head bearing 🛠.....	36
6.3	Kill switch.....	11	11.14	Removing the start number plate .....	36
6.4	Opening filler cap.....	11	11.15	Installing the start number plate .....	37
6.5	Closing the filler cap .....	12	11.16	Dismounting the front fender .....	37
6.6	Fuel tap .....	12	11.17	Installing the front fender .....	37
6.7	Choke.....	12	11.18	Removing the right side cover .....	38
6.8	Kick starter.....	13	11.19	Installing the right side cover .....	38
6.9	Foot brake lever .....	13	11.20	Securing right side cover 🛠.....	39
6.10	Plug-in stand.....	13	11.21	Removing the left side cover .....	39
6.11	Service hour counter.....	13	11.22	Installing the left side cover .....	40
7	PREPARING FOR USE.....	14	11.23	Securing left side cover 🛠.....	41
7.1	Advice on first use .....	14	11.24	Removing the shock absorber 🛠.....	41
7.2	Running in the engine .....	15	11.25	Installing the shock absorber 🛠.....	42
8	RIDING INSTRUCTIONS .....	16	11.26	Removing the seat .....	42
8.1	Checks and maintenance measures when preparing for use.....	16	11.27	Mounting the seat .....	43
8.2	Starting .....	16	11.28	Removing the air filter 🛠.....	43
8.3	Starting off .....	17	11.29	Installing the air filter 🛠.....	43
8.4	Riding.....	17	11.30	Cleaning the air filter and air filter box 🛠.....	44
8.5	Applying the brakes .....	17	11.31	Removing the main silencer.....	44
8.6	Stopping, parking .....	17	11.32	Installing the main silencer.....	45
8.7	Transport.....	18	11.33	Changing the glass fiber yarn filling of the main silencer 🛠.....	45
8.8	Refueling .....	18			
9	SERVICE SCHEDULE.....	20			
9.1	Additional information.....	20			
9.2	Required work.....	20			
9.3	Recommended work.....	21			

11.34	Removing the engine sprocket cover 	46	15.9	Installing the clutch cover 	76
11.35	Installing the engine sprocket cover 	46	16	SERVICE WORK ON THE ENGINE	77
11.36	Checking the chain for dirt	46	16.1	Checking the gear oil level	77
11.37	Cleaning the chain	46	16.2	Changing the gear oil 	77
11.38	Checking the chain tension	47	16.3	Adding gear oil 	78
11.39	Adjusting the chain tension	47	17	CLEANING, CARE	79
11.40	Checking the chain, rear sprocket, engine sprocket and chain guide	48	17.1	Cleaning the motorcycle	79
11.41	Adjusting the chain guide 	50	18	STORAGE	80
11.42	Checking the frame 	50	18.1	Storage	80
11.43	Checking the swingarm 	50	18.2	Preparing for use after storage	80
11.44	Removing the fuel tank 	50	19	TROUBLESHOOTING	81
11.45	Installing the fuel tank 	51	20	TECHNICAL DATA	83
11.46	Checking the routing of the throttle cable	52	20.1	Engine	83
11.47	Checking the rubber grip	53	20.2	Engine tightening torques	83
11.48	Additionally securing the rubber grip	53	20.3	Carburetor with carburetor tuning	84
12	BRAKE SYSTEM	54	20.4	Capacities	84
12.1	Checking play of handbrake lever	54	20.4.1	Gear oil	84
12.2	Adjusting the play of the hand brake lever	54	20.4.2	Coolant	84
12.3	Adjusting the basic position of the hand brake lever	54	20.4.3	Fuel	84
12.4	Checking the brake discs	55	20.5	Chassis	84
12.5	Checking the front brake fluid level	55	20.6	Tires	85
12.6	Adding front brake fluid 	56	20.7	Fork	85
12.7	Checking the front brake linings	57	20.8	Shock absorber	85
12.8	Changing the front brake linings 	57	20.9	Chassis tightening torques	86
12.9	Checking the free travel of the foot brake lever	59	21	SUBSTANCES	87
12.10	Adjusting the free travel of the foot brake lever 	60	22	AUXILIARY SUBSTANCES	89
12.11	Adjusting the basic position of the foot brake lever 	60	23	STANDARDS	90
12.12	Checking the rear brake fluid level	61	24	LIST OF ABBREVIATIONS	91
12.13	Adding rear brake fluid 	61		INDEX	92
12.14	Checking the rear brake linings	62			
12.15	Changing the rear brake linings 	62			
13	WHEELS, TIRES	65			
13.1	Removing the front wheel 	65			
13.2	Installing the front wheel 	65			
13.3	Removing the rear wheel 	66			
13.4	Installing the rear wheel 	66			
13.5	Checking the tire condition	67			
13.6	Checking tire air pressure	68			
13.7	Checking spoke tension	68			
14	COOLING SYSTEM	69			
14.1	Cooling system	69			
14.2	Checking the antifreeze and coolant level	69			
14.3	Checking the coolant level	70			
14.4	Draining the coolant 	70			
14.5	Refilling with coolant 	71			
15	TUNING THE ENGINE	72			
15.1	Checking the installation position of the throttle grip	72			
15.2	Checking the play in the throttle cable	72			
15.3	Adjusting the play in the throttle cable 	72			
15.4	Carburetor - idle	73			
15.5	Carburetor – adjusting the idle speed 	73			
15.6	Checking the clutch setting 	74			
15.7	Removing the clutch cover 	75			
15.8	Adjusting the clutch 	75			

## 1.1 Symbols used

The meaning of specific symbols is described below.

---

	Indicates an expected reaction (e.g. of a work step or a function).
	Indicates an unexpected reaction (e.g. of a work step or a function).
	All work marked with this symbol requires specialist knowledge and technical understanding. In the interest of your child's safety, have these jobs performed in an authorized Husqvarna Motorcycles workshop. There, your motorcycle will be optimally cared for by specially trained experts using the specialist tools required.
	Indicates a page reference (more information is provided on the specified page).
	Indicates information with more details or tips.
	Indicates the result of a testing step.

---

## 1.2 Formats used

The typographical formats used in this document are explained below.

---

<b>Proprietary name</b>	Indicates a proprietary name.
<b>Name<sup>®</sup></b>	Indicates a protected name.
<b>Brand<sup>™</sup></b>	Indicates a brand available on the open market.
<b><u>Underlined terms</u></b>	Refer to technical details of the vehicle or indicate technical terms, which are explained in the glossary.

---

## 2.1 Use definition – intended use

Husqvarna motorcycles are designed and built to withstand the normal stresses and strains of competitive use. The motorcycles comply with currently valid regulations and categories of the top international motorsport organizations.



### Info

The motorcycle may only be used in closed off areas remote from public road traffic.

## 2.2 Safety advice

A number of safety instructions need to be followed to operate the vehicle safely. Therefore, read this manual carefully. The safety instructions are highlighted in the text and are referred to at the relevant passages.



### Info

The vehicle has various information and warning labels at prominent locations. Do not remove information/warning labels. If they are missing, you or others may not recognize dangers and may therefore be injured.

## 2.3 Degrees of risk and symbols



### Danger

Indicates a danger that will immediately and invariably lead to fatal or serious permanent injury if the appropriate measures are not taken.



### Warning

Indicates a danger that is likely to lead to fatal or serious injury if the appropriate measures are not taken.



### Caution

Indicates a danger that may lead to minor injuries if the appropriate measures are not taken.

### Note

Indicates a danger that will lead to considerable machine and material damage if the appropriate measures are not taken.



### Warning

Indicates a danger that will lead to environmental damage if the appropriate measures are not taken.

## 2.4 Tampering warning

Tampering with the noise control system is prohibited. Federal law prohibits the following acts or the causing thereof:

- 1 The removal or rendering inoperative by any person other than for purposes of maintenance, repair, or replacement, of any device or element of design incorporated into any new vehicle for the purpose of noise control prior to its sale or delivery to the ultimate purchaser or while it is in use, or
- 2 the use of the vehicle after such device or element of design has been removed or rendered inoperative by any person.

Among those acts presumed to constitute tampering are the acts listed below:

- 1 Removal or puncturing of the main silencer, baffles, header pipes or any other components which conduct exhaust gases.
- 2 Removal or puncturing of parts of the intake system.
- 3 Lack of proper maintenance.
- 4 Replacing moving part of the vehicle, or parts of the exhaust or intake system, with parts other than those specified by the manufacturer.

## 2.5 Safe operation



### Danger

**Danger of accidents** A rider who is not fit to ride poses a danger to him or herself and others.

- Do not operate the vehicle if you are not fit to ride due to alcohol, drugs or medication.
- Do not operate the vehicle if you are physically or mentally impaired.



### Danger

**Danger of poisoning** Exhaust gases are toxic and inhaling them may result in unconsciousness and death.

- Always make sure there is sufficient ventilation when running the engine.
- Use an effective exhaust extraction system when starting or running the engine in an enclosed space.

-  **Warning**  
**Danger of burns** Some vehicle components become very hot when the vehicle is operated.
- Do not touch any parts such as the exhaust system, radiator, engine, shock absorber, or brake system before the vehicle parts have cooled down.
  - Let the vehicle parts cool down before you perform any work on the vehicle.

Only operate the vehicle when it is in perfect technical condition, in accordance with its intended use, and in a safe and environmentally compatible manner.

The vehicle should only be used by trained persons.

Have malfunctions that impair safety promptly eliminated by an authorized Husqvarna Motorcycles workshop.

Adhere to the information and warning labels on the vehicle.

### 2.6 Protective clothing

-  **Warning**  
**Risk of injury** Missing or poor protective clothing presents an increased safety risk.

- Ensure your child wears appropriate protective clothing such as helmet, boots, gloves as well as trousers and a jacket with protectors on all rides.
- Always use protective clothing for your child that is in good condition and meets the legal requirements.
- When you ride a motorcycle, set an example for your child and wear suitable protective clothing.

In the interest of your child's safety, Husqvarna Motorcycles recommends that only operating the vehicle while wearing protective clothing.

### 2.7 Work rules

Special tools are necessary for certain tasks. The tools are not contained in the vehicle but can be ordered under the number in parentheses. E.g.: bearing puller (15112017000)

During assembly, non-reusable parts (e.g. self-locking screws and nuts, seals and seal rings, O-rings, pins, lock washers) must be replaced by new parts.

In some instances, a thread locker (e.g. **Loctite**<sup>®</sup>) is required. The manufacturer instructions for use must be followed.

After disassembly, clean the parts that are to be reused and check them for damage and wear. Change damaged or worn parts.

After you complete the repair or service work, check the operating safety of the vehicle.

### 2.8 Environment

If you use your motorcycle responsibly, you can ensure that problems and conflicts do not occur. To protect the future of the motorcycle sport, make sure that you use your motorcycle legally, be environmentally aware, and respect the rights of others. When disposing of used oil, other operating and auxiliary fluids, and used components, comply with the laws and regulations of the respective country.

Because motorcycles are not subject to the EU regulations governing the disposal of used vehicles, there are no legal regulations that pertain to the disposal of an end-of-life motorcycle. Your authorized Husqvarna Motorcycles dealer will be glad to advise you.

### 2.9 Owner's Manual

It is important that you read this Owner's Manual carefully and completely before your child makes his or her first trip. The Owner's Manual contains useful information and many tips for you and your child on how to operate, handle, and maintain your motorcycle. This is the only way for you to find out how to ideally customize the vehicle and how to protect your child from injury.

Keep the Owner's Manual in an accessible place to enable you to refer to it as needed.

If you would like to know more about the vehicle or have questions on the material you read, please contact an authorized Husqvarna Motorcycles dealer.

The Owner's Manual is an important component of the vehicle and must be handed over to the new owner if the vehicle is sold.



## 3.1 Manufacturer and implied warranty

The work prescribed in the service schedule must be carried out by an authorized Husqvarna Motorcycles workshop only and confirmed both in the customer's Service & Warranty Booklet and in the **Husqvarna Motorcycles Dealer.net**; otherwise, all warranty claims will be void. Damage or secondary damage caused by tampering with and/or conversions on the vehicle are not covered by the warranty.

Additional information on the manufacturer or implied warranty and the procedures involved can be found in the Service & Warranty Booklet.

## 3.2 Operating and auxiliary substances



### Warning

**Environmental hazard** Improper handling of fuel is a danger to the environment.

- Do not allow fuel to enter the groundwater, the soil, or the sewage system.

Use operating and auxiliary substances (such as fuel and lubricants) as specified in the Owner's Manual.

## 3.3 Spare parts, accessories

For the safety of your child, only use spare parts and accessory products that are approved and/or recommended by Husqvarna Motorcycles and have them installed by an authorized Husqvarna Motorcycles workshop. Husqvarna Motorcycles accepts no liability for other products and any resulting damage or loss.

Certain spare parts and accessory products are specified in parentheses in the descriptions. Your authorized Husqvarna Motorcycles dealer will be glad to advise you.

The current Husqvarna Motorcycles accessories for your vehicle can be found on the Husqvarna Motorcycles website. International Husqvarna Motorcycles website: [www.husqvarna-motorcycles.com](http://www.husqvarna-motorcycles.com)

## 3.4 Service

A prerequisite for perfect operation and prevention of premature wear is that the service, care, and tuning work on the engine and chassis is properly carried out as described in the Owner's Manual. Incorrect adjustment and tuning of the engine and chassis can lead to damage and breakage of components.

Use of the vehicle under difficult conditions, such as on sand or on wet and muddy surfaces, can lead to considerably more rapid wear of components such as the drive train, brake system, or suspension components. For this reason, it may be necessary to inspect or replace parts before the next scheduled service.

It is imperative that you adhere to the stipulated run-in times and service intervals. If you observe these exactly, you will ensure a much longer service life for your motorcycle.

## 3.5 Figures

The figures contained in the manual may depict special equipment.

In the interest of clarity, some components may be shown disassembled or may not be shown at all. It is not always necessary to disassemble the component to perform the activity in question. Please follow the instructions in the text.

## 3.6 Customer service

Your authorized Husqvarna Motorcycles dealer will be happy to answer any questions you may have regarding your vehicle and Husqvarna Motorcycles.

A list of authorized Husqvarna Motorcycles dealers can be found on the Husqvarna Motorcycles website. International Husqvarna Motorcycles website: [www.husqvarna-motorcycles.com](http://www.husqvarna-motorcycles.com)

## 4.1 View of vehicle, front left (example)



- |   |                         |
|---|-------------------------|
| 1 | Filler cap              |
| 2 | Quick release of seat   |
| 3 | Chain guide             |
| 4 | Plug-in stand (📖 p. 13) |
| 5 | Choke (📖 p. 12)         |
| 6 | Fuel tap (📖 p. 12)      |

## 4.2 View of vehicle, rear right (example)

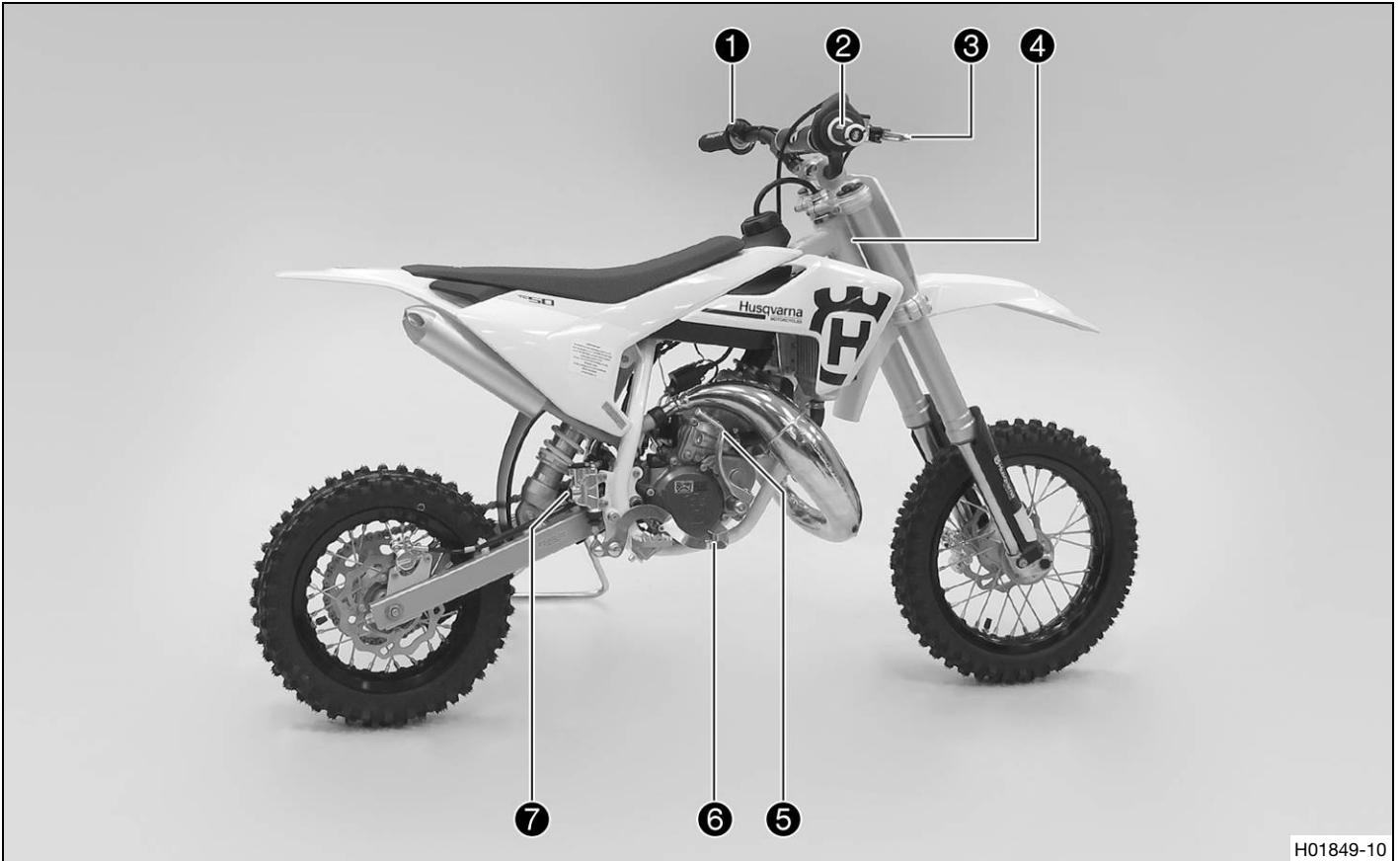

H01849-10

1	Kill switch (📖 p. 11)
2	Throttle grip (📖 p. 11)
3	Hand brake lever (📖 p. 11)
4	Chassis number (📖 p. 10)
5	Kick starter (📖 p. 13)
6	Foot brake lever (📖 p. 13)
7	Level viewer for brake fluid, rear

## 5.1 Chassis number

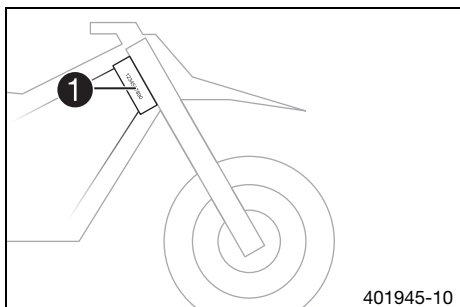

The chassis number ❶ is stamped on the right side of the steering head.

## 5.2 Type label

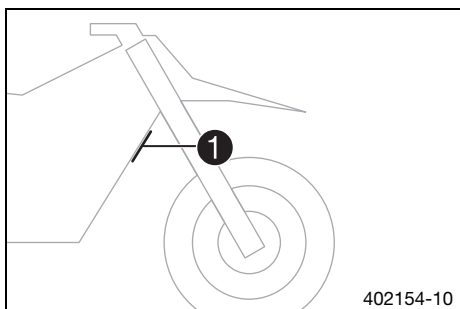

The type label ❶ is located on the front frame tube.

## 5.3 Engine number

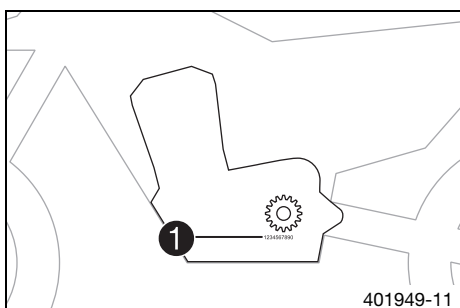

The engine number ❶ is located on the left side of the engine under the engine sprocket.

## 5.4 Fork part number

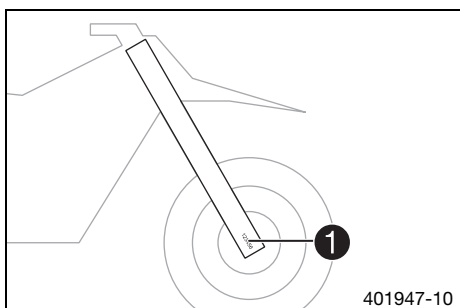

The fork part number ❶ is stamped on the outside of the axle clamp.

## 5.5 Shock absorber article number

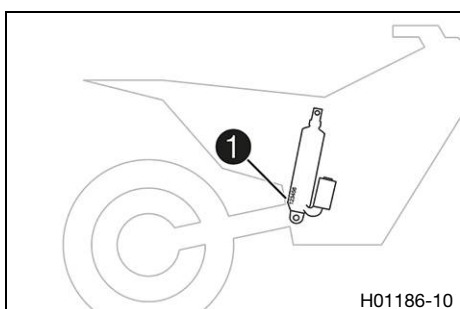

The shock absorber article number ❶ is stamped on the bottom of the shock absorber toward the right-hand side.

## 6.1 Hand brake lever

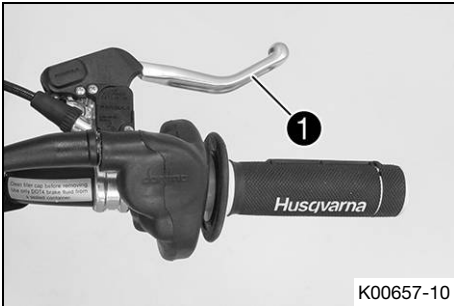

Hand brake lever ❶ is fitted on the right side of the handlebar. The hand brake lever is used to activate the front brake.

## 6.2 Throttle grip

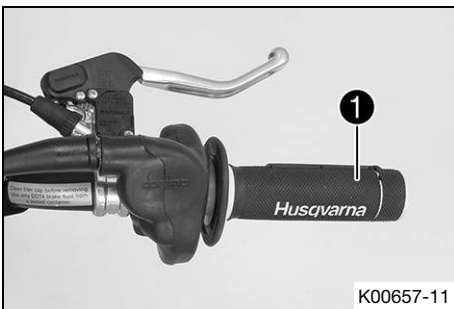

Throttle grip ❶ is fitted on the right side of the handlebar.

## 6.3 Kill switch



Kill switch ❶ is fitted on the left side of the handlebar.

### Possible states

- Kill switch ☒ in basic position – In this position, the ignition circuit is closed, and the engine can be started.
- Kill switch ☒ pressed – In this position, the ignition circuit is interrupted, a running engine stops, and a non-running engine will not start.

## 6.4 Opening filler cap



### Danger

**Fire hazard** Fuel is highly flammable.

The fuel in the fuel tank expands when warm and can escape if overfilled.

- Do not refuel the vehicle in the vicinity of open flames or lit cigarettes.
- Switch off the engine for refueling.
- Make sure that no fuel is spilled; particularly not on hot parts of the vehicle.
- If any fuel is spilled, wipe it off immediately.
- Observe the specifications for refueling.



### Warning

**Danger of poisoning** Fuel is poisonous and a health hazard.

- Avoid skin, eye and clothing contact with fuel.
- Immediately consult a doctor if you swallow fuel.
- Do not inhale fuel vapors.
- In case of skin contact, rinse the affected area with plenty of water.
- Rinse the eyes thoroughly with water, and consult a doctor in case of fuel contact with the eyes.
- Change your clothing in case of fuel spills on them.
- Keep fuels correctly in a suitable canister, and out of the reach of children.



**Warning**

**Environmental hazard** Improper handling of fuel is a danger to the environment.

- Do not allow fuel to enter the groundwater, the soil, or the sewage system.

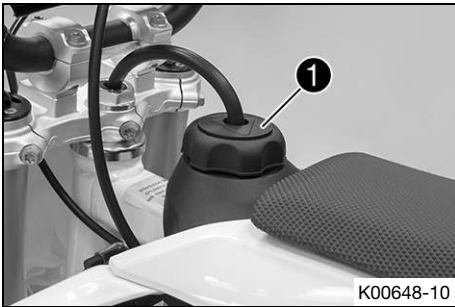

K00648-10

- Turn the tank cap ❶ counterclockwise and pull it up.

## 6.5 Closing the filler cap

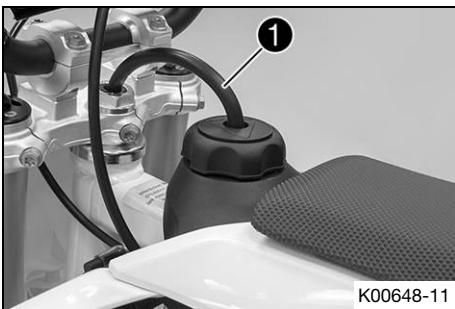

K00648-11

- Mount the filler cap and turn it clockwise until the fuel tank is firmly closed.



**Info**

Route fuel tank breather hose ❶ without kinks.

## 6.6 Fuel tap



K00649-10

Fuel tap ❶ is on the left of the fuel tank.

**Possible states**

- Fuel tap is closed – The knurled screw is turned all the way clockwise. Fuel cannot flow out of the fuel tank.
- Fuel tap is open – The knurled screw is turned all the way counterclockwise. Fuel can flow out of the fuel tank.

## 6.7 Choke

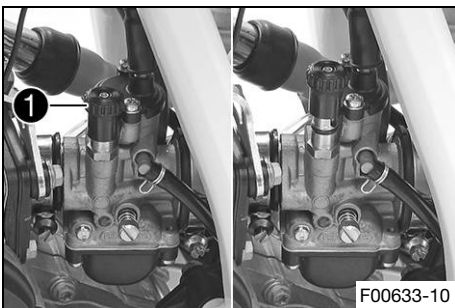

F00633-10

Choke ❶ is fitted on the left side of the carburetor.

Activating the choke function frees a drill hole in the carburetor through which the engine can draw extra fuel. This results in a richer fuel-air mixture, which is needed for a cold start.



**Info**

If the engine is warm, the choke function must be deactivated.

**Possible states**

- Choke function activated – The choke lever is pulled out to the stop.
- Choke function deactivated – The choke lever is pushed in to the stop.

## 6.8 Kick starter

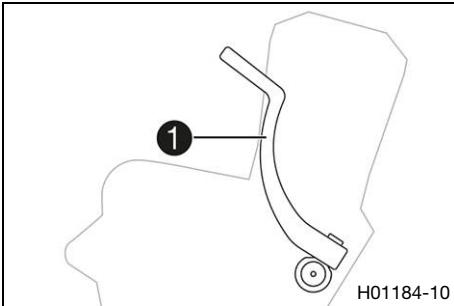

Kick starter **1** is fitted on the right side of the engine.  
The kick starter can be swiveled.



### Info

Before riding, swing the kick starter inwards towards the engine.

## 6.9 Foot brake lever

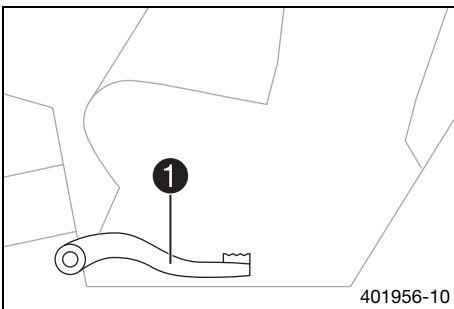

Foot brake lever **1** is located in front of the right footrest.  
The rear brake is engaged with the foot brake lever.

## 6.10 Plug-in stand

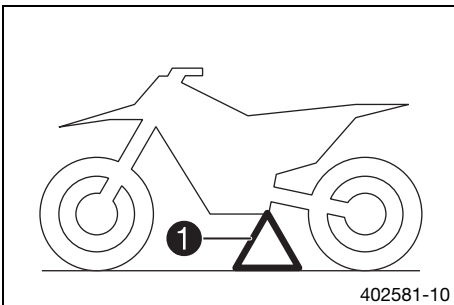

The fixture for plug-in stand **1** is located on the frame on the left side of the vehicle.  
The plug-in stand is used to park the motorcycle.



### Info

Remove the plug-in stand before riding.

## 6.11 Service hour counter



Service hour counter **1** is attached to the tail section under the left-hand side cover.  
It shows the total number of service hours of the engine.  
The service hour counter begins counting when the engine is started and stops when the engine is switched off.



### Info

The value indicated by the service hour counter cannot be cleared or adjusted.

## 7.1 Advice on first use



### Warning

**Danger of accidents** A lack of physical and mental readiness on the part of the child poses a major risk. Children often underestimate or fail to recognize dangerous situations.

- Your child must already be able to ride a bicycle.
- Your child must be able to put the vehicle upright independently after a fall.
- Your child must understand that regulations and instructions from you or from other guardians must be followed.
- Make it clear to your child that he or she should not, under any circumstances, operate the vehicle without supervision.
- Make it clear to your child that he or she may only drive at speeds commensurate with the child's riding abilities and the road conditions.
- Do not ask too much of your child.  
Do not consider participation in competitive activities until your child's stamina, riding techniques and motivation are at the necessary levels.
- Only let your child ride on the vehicle if he or she is physically and mentally ready.



### Warning

**Risk of injury** Missing or poor protective clothing presents an increased safety risk.

- Ensure your child wears appropriate protective clothing such as helmet, boots, gloves as well as trousers and a jacket with protectors on all rides.
- Always use protective clothing for your child that is in good condition and meets the legal requirements.
- When you ride a motorcycle, set an example for your child and wear suitable protective clothing.



### Warning

**Danger of crashing** Different tire tread patterns on the front and rear wheel impair the handling characteristic. Different tire tread patterns can make the vehicle significantly more difficult to control.

- Make sure that only tires with a similar tire tread pattern are fitted to the front and rear wheel.



### Warning

**Danger of accidents** An unadapted riding style constitutes a major risk.

- Ensure that your child adapts the riding speed to the road conditions and to his or her riding abilities.



### Warning

**Danger of accidents** The vehicle is not designed to carry passengers.

- Make it clear to your child that he or she must not carry passengers.



### Warning

**Danger of accidents** The brake system fails in the event of overheating. If the foot brake lever is not released, the brake linings drag continuously.

- Ensure that your child raises his or her foot from the foot brake lever if he or she does not want to brake.



### Warning

**Danger of accidents** The suspension components will become damaged or destroyed if overloaded.

- Do not exceed the maximum permissible weight of the rider.



### Warning

**Risk of misappropriation** People who act without authorization endanger themselves and others.

- Do not leave the vehicle unattended if the engine is running.
- Protect the vehicle against access by unauthorized persons.



### Info

When using your motorcycle, remember that others may feel disturbed by excessive noise.

- Make sure that the pre-delivery inspection work has been carried out by an authorized Husqvarna Motorcycles workshop.  
✓ You receive a delivery certificate and the Service and Warranty Booklet at vehicle handover.



- Carefully read the entire Owner's Manual together with your child before going for the first ride.

**i Info**

Pay special attention to the safety warnings and injury risks.  
Explain to your child the techniques of riding and falling, e.g. how shifting weight can influence handling characteristics.

- Familiarize your child with the controls.
- Adjust the basic position of the hand brake lever. (📖 p. 54)
- Adjust the basic position of the foot brake lever. 🦶 (📖 p. 60)
- Before using the vehicle for the first time, ensure that the basic settings of the chassis are suitable for the weight of your child.
- Accustom your child to the handling of the motorcycle on suitable terrain, preferably on a large open meadow.

**i Info**

To give your child a feeling for the brake system, you should push your child at first. Do not start the engine until your child is able to apply the necessary front brake pressure.  
Initially, let your child ride to another person who can help your child stop and turn.

- Erect obstacles for your child to navigate around to accustom your child to handling the vehicle.
- Your child should also try to ride as slowly as possible and in a standing position to get a better feeling for the vehicle.
- Do not let your child ride on terrain that exceeds your child's capabilities and experience.
- Your child should hold the handlebar firmly with both hands and keep his or her feet on the footrests when riding.
- Make sure the maximum permissible weight of the rider is not exceeded.

Guideline

Maximum rider weight	≤ 45 kg (≤ 99 lb.)
Maximum rider size	< 130 cm (< 51.2 in)

- Check the spoke tension. (📖 p. 68)

**i Info**

The spoke tension must be checked after half an hour of operation.

- Run the engine in. (📖 p. 15)

## 7.2 Running in the engine

- During the running-in phase, do not exceed the specified engine performance.

Guideline

Maximum engine performance	
During the first 3 operating hours	< 70 %
During the first 5 operating hours	< 100 %

- Avoid fully opening the throttle!

## 8.1 Checks and maintenance measures when preparing for use

### Info

Before every trip, check the condition of the vehicle and ensure that it is safe to operate. The vehicle must be in perfect technical condition when it is being operated.

- Check the gear oil level. (📖 p. 77)
- Check the front brake fluid level. (📖 p. 55)
- Check the rear brake fluid level. (📖 p. 61)
- Check the front brake linings. (📖 p. 57)
- Check the rear brake linings. (📖 p. 62)
- Check that the brake system is functioning properly.
- Check the coolant level. (📖 p. 70)
- Check the chain for dirt. (📖 p. 46)
- Check the chain, rear sprocket, engine sprocket and chain guide. (📖 p. 48)
- Check the chain tension. (📖 p. 47)
- Check the tire condition. (📖 p. 67)
- Check the tire air pressure. (📖 p. 68)
- Check the spoke tension. (📖 p. 68)

### Info

The spoke tension must be checked regularly as incorrect spoke tension will strongly impair riding safety.

- Clean the dust boots of the fork legs. (📖 p. 31)
- Bleed the fork legs. (📖 p. 30)
- Check the air filter.
- Check the settings of all controls and ensure that they can be operated smoothly.
- Check all screws, nuts, and hose clamps regularly for tightness.
- Check the fuel level.

## 8.2 Starting

### Danger

**Danger of poisoning** Exhaust gases are toxic and inhaling them may result in unconsciousness and death.

- Always make sure there is sufficient ventilation when running the engine.
- Use an effective exhaust extraction system when starting or running the engine in an enclosed space.

### Note

**Engine failure** High rpm with a cold engine negatively impacts the lifespan of the engine.

- Ensure that the engine is always warmed up at low engine speeds.

### Info

If the motorcycle is unwilling to start, the cause can be old fuel in the float chamber. The flammable elements of the fuel evaporate after a long time of standing. If the float chamber is filled with fresh fuel, the engine starts immediately.

### The motorcycle has been out of use for more than 1 week

- Empty the carburetor float chamber. 🛠️
- Turn the knurled screw on the fuel tap all the way counterclockwise.
  - ✓ Fuel can flow from the fuel tank to the carburetor.

### The engine is cold

- Raise the motorcycle with a lift stand. (📖 p. 30)

### Info

The rear wheel must not be in contact with the ground.

- Pull the choke knob fully out and turn it by max. ¼ turn.
- Forcefully step on the kick starter, pushing it all the way forward.

**Info**

Do not open the throttle.

## 8.3 Starting off

**Info**

The plug-in stand must be removed before riding.

- Open the throttle carefully.

## 8.4 Riding

**Info**

If unusual noises occur while riding, stop immediately, switch off the engine, and contact an authorized Husqvarna Motorcycles workshop.

- If the choke function was activated, deactivate it after the engine has warmed up.
- After reaching maximum speed by fully opening the throttle grip, turn the throttle back so it is ¾ open. This will barely reduce the speed but fuel consumption will be considerably lower.
- Your child should always open the throttle only as much as the engine can handle – abruptly opening the throttle increases fuel consumption.
- Your child should switch off the engine if longer periods of engine idling or standing still are expected.

Guideline

≥ 2 min

## 8.5 Applying the brakes

**Warning**

**Danger of accidents** Excessively forceful application of the brakes blocks the wheels.

- Explain to your child that he or she must adapt the braking to the traffic situation and the road conditions.

**Warning**

**Danger of accidents** A spongy pressure point on the front or rear brake reduces braking efficiency.

- Check the brake system and do not allow your child to continue riding until the problem is eliminated. (Your authorized Husqvarna Motorcycles workshop will be glad to help.)

**Warning**

**Danger of accidents** Moisture and dirt impair the brake system.

- Explain to your child that he or she must brake carefully several times to dry out and remove dirt from the brake linings and the brake discs.

- On sandy, wet, or slippery surfaces, use the rear brake.
- Always finish braking before you go into a bend.

## 8.6 Stopping, parking

**Warning**

**Risk of misappropriation** People who act without authorization endanger themselves and others.

- Do not leave the vehicle unattended if the engine is running.
- Protect the vehicle against access by unauthorized persons.

**Warning**

**Danger of burns** Some vehicle components become very hot when the vehicle is operated.

- Do not touch any parts such as the exhaust system, radiator, engine, shock absorber, or brake system before the vehicle parts have cooled down.
- Let the vehicle parts cool down before you perform any work on the vehicle.

## Note

**Material damage** The vehicle may be damaged by incorrect procedure when parking. Significant damage may be caused if the vehicle rolls away or falls over. The components for parking the vehicle are designed only for the weight of the vehicle.

- Park the vehicle on a firm and level surface.
- Ensure that nobody sits on the vehicle when the vehicle is parked on a stand.

## Note

**Fire hazard** Hot vehicle components pose a fire hazard and explosion risk.

- Do not park the vehicle near to materials which are highly flammable or explosive.
- Allow the vehicle to cool down before covering it.

- 
- Apply the brakes on the motorcycle.
  - Press and hold the kill switch  while the engine is idling until the engine stops.
  - Turn the knurled screw on the fuel tap all the way clockwise.
  - Park the motorcycle on firm ground.

## 8.7 Transport

### Note

**Danger of damage** The parked vehicle can roll away or fall over.

- Park the vehicle on a firm and level surface.

### Note

**Fire hazard** Hot vehicle components pose a fire hazard and explosion risk.

- Do not park the vehicle near to materials which are highly flammable or explosive.
- Allow the vehicle to cool down before covering it.

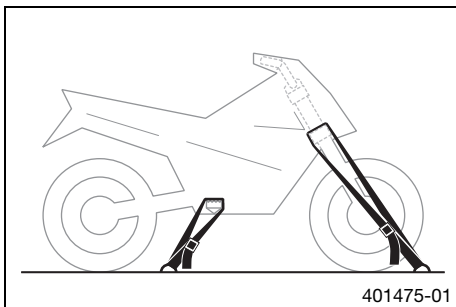

- Switch off the engine.
- Use tension belts or other suitable devices to secure the motorcycle against accidents or falling over.

## 8.8 Refueling



### Danger

**Fire hazard** Fuel is highly flammable.

The fuel in the fuel tank expands when warm and can escape if overfilled.

- Do not refuel the vehicle in the vicinity of open flames or lit cigarettes.
- Switch off the engine for refueling.
- Make sure that no fuel is spilled; particularly not on hot parts of the vehicle.
- If any fuel is spilled, wipe it off immediately.
- Observe the specifications for refueling.



### Warning

**Danger of poisoning** Fuel is poisonous and a health hazard.

- Avoid skin, eye and clothing contact with fuel.
- Immediately consult a doctor if you swallow fuel.
- Do not inhale fuel vapors.
- In case of skin contact, rinse the affected area with plenty of water.
- Rinse the eyes thoroughly with water, and consult a doctor in case of fuel contact with the eyes.
- Change your clothing in case of fuel spills on them.



**Warning**

**Environmental hazard** Improper handling of fuel is a danger to the environment.

- Do not allow fuel to enter the groundwater, the soil, or the sewage system.

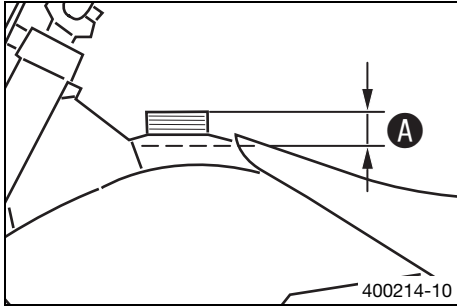

- Switch off the engine.
- Open the filler cap. (📖 p. 11)
- Fill the fuel tank with fuel up to level **A**.

Guideline

Level <b>A</b>	35 mm (1.38 in)	
----------------	-----------------	--

Fuel tank capacity, approx.	2.3 l (2.4 qt.)	Super unleaded (95 octane) mixed with 2-stroke engine oil (1:60) (📖 p. 88)
-----------------------------	-----------------	--

Engine oil, 2-stroke (📖 p. 87)		
--------------------------------	--	--

- Close the filler cap. (📖 p. 12)

## 9.1 Additional information

Any further work that results from the required work or from the recommended work must be ordered separately and can be invoiced separately.

## 9.2 Required work

	Every 40 operating hours	Every 20 operating hours	Once after 10 operating hours
Check the front brake linings. (📖 p. 57)	○	●	●
Check the rear brake linings. (📖 p. 62)	○	●	●
Check the brake discs. (📖 p. 55)	○	●	●
Check the brake lines for damage and leakage.	○	●	●
Change the foot brake cylinder seals. 🛠️		●	●
Check the rear brake fluid level. (📖 p. 61)	○	●	●
Check the free travel of the foot brake lever. (📖 p. 59)	○	●	●
Check the frame and swingarm. 🛠️		●	●
Check the swingarm bearing for backlash.		●	●
Check the heim joint for play.		●	●
Check the tire condition. (📖 p. 67)	○	●	●
Check the tire air pressure. (📖 p. 68)	○	●	●
Check the wheel bearing for play.		●	●
Check the wheel hubs. 🛠️		●	●
Check the rim run-out. 🛠️	○	●	●
Check the spoke tension. (📖 p. 68)	○	●	●
Check the chain, rear sprocket, engine sprocket and chain guide. (📖 p. 48)	○	●	●
Check the chain tension. (📖 p. 47)	○	●	●
Grease all moving parts (e.g., hand lever, chain, ...) and check for smooth operation. 🛠️	○	●	●
Check the front brake fluid level. (📖 p. 55)	○	●	●
Check the play of the handbrake lever. (📖 p. 54)	○	●	●
Check play of steering head bearing. (📖 p. 35)	○	●	●
Change the gear oil. 🛠️ (📖 p. 77)	○		●
Check the gear oil level. (📖 p. 77)		●	●
Check all hoses (e.g. fuel, cooling, bleeder, drainage, etc.) and sleeves for cracking, leaks, and incorrect routing. 🛠️	○	●	●
Check the antifreeze and coolant level. (📖 p. 69)	○	●	●
Check the cables for damage and routing without sharp bends. 🛠️	○	●	●
Check that the throttle cables are undamaged, routed without sharp bends, and set correctly.	○	●	●
Clean the air filter and air filter box. 🛠️ (📖 p. 44)	○	●	●
Change the glass fiber yarn filling of the main silencer. 🛠️ (📖 p. 45)		●	●
Check the screws and nuts for tightness. 🛠️	○	●	●
Check idle. 🛠️	○	●	●
Check the clutch setting. 🛠️ (📖 p. 74)		●	●
Final check: Check the vehicle for safe operation and take a test ride. 🛠️	○	●	●
Make the service entry in <b>Husqvarna Motorcycles Dealer.net</b> and in the Service and Warranty Booklet. 🛠️	○	●	●

○ One-time interval

● Periodic interval

## 9.3 Recommended work

	Every 20 operating hours	Every 40 operating hours	Every 80 operating hours	Annually
Change the front brake fluid. 🛠️				•
Change the rear brake fluid. 🛠️				•
Service the fork. 🛠️		•	•	
Service the shock absorber. 🛠️			•	
Grease the steering head bearing. 🛠️ (📖 p. 36)				•
Check/adjust the carburetor components. 🛠️				•
Perform minor engine service. (Change the spark plug. Check the cylinder and piston. Check the inlet membrane.) 🛠️	•	•	•	
Perform major engine service including removing and installing engine. (Check the clutch. Change the piston. Change the connecting rod, conrod bearing, and crank pin. Check the transmission. Change the spark plug connector. Change the crankshaft bearing. Change all engine bearings.) 🛠️				•

- Periodic interval

## 10.1 Checking the basic chassis setting with the rider's weight

**i Info**

When adjusting the basic chassis setting, first adjust the shock absorber and then the fork.

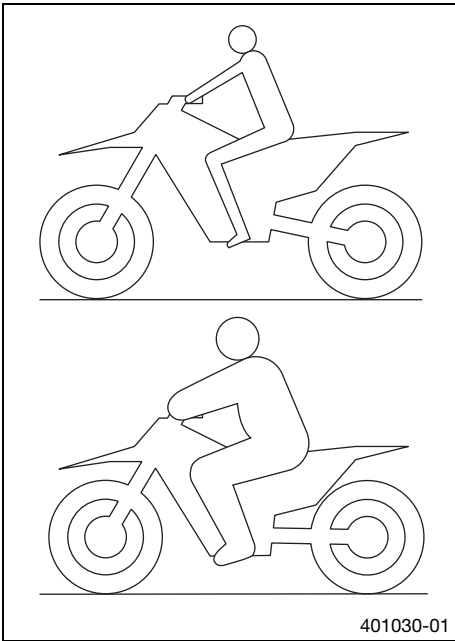

401030-01

- For optimal motorcycle riding characteristics and to avoid damage to forks, shock absorbers, swingarm and frame, the basic settings of the suspension components must match the rider's weight.
- On delivery, Husqvarna offroad motorcycles are adjusted for an average rider's weight (with full protective clothing).

Guideline

Standard rider weight	25... 35 kg (55... 77 lb.)
-----------------------	----------------------------

- If the rider's weight is above or below this range, the basic setting of the suspension components must be adjusted accordingly.
- Small weight differences can be compensated by adjusting the spring preload, but in the case of large weight differences, the springs must be replaced.

## 10.2 Air suspension AER 35

Air suspension **WP Performance Systems AER 35** is used in the fork.

In this system, suspension is located in the left fork leg and damping in the right fork leg.

As fork springs are no longer required, a significant weight advantage is achieved when compared to conventional forks. The response on slightly uneven surfaces is significantly improved.

In normal driving mode, suspension is provided exclusively by an air cushion. A steel spring is located in the left fork leg as an end stop.

**i Info**

If the fork is frequently overloaded, then the air pressure in the fork must be increased to avoid damage to the fork and frame.

The air pressure in the fork can be quickly adjusted for the rider's weight, surface conditions and the rider's preference using a fork pump. The fork does not have to be detached. The time consuming mounting of harder or softer fork springs is not required.

If the air chamber loses air due to a damaged seal, the fork will still not sag. In this case the air is retained in the fork. The suspension travel is maintained as far as possible. The damping becomes harder and the riding comfort reduces.

The rebound damping can be adjusted.

The rebound adjustment is located at the upper end of the right fork leg.

## 10.3 Compression damping of the shock absorber

The compression damping of the shock absorber is divided into two ranges: high-speed and low-speed.

High-speed and low-speed refer to the compression speed of the rear wheel suspension and not to the vehicle speed.

The high-speed setting, for example, has an effect on the landing after a jump: the rear wheel suspension compresses quickly.

The low-speed setting, for example, has an effect when riding over long ground swells: the rear wheel suspension compresses slowly.

These two ranges can be adjusted separately, although the transition between high-speed and low-speed is gradual. Thus, changes in the high-speed range affect the compression damping in the low-speed range and vice versa.



## 10.4 Adjusting the low-speed compression damping of the shock absorber

**Caution**  
**Risk of injury** Parts of the shock absorber will fly off if the shock absorber is disassembled incorrectly. The shock absorber is filled with highly compressed nitrogen.

- Please follow the description provided. (Your authorized Husqvarna Motorcycles workshop will be glad to help.)

**Info**  
 The effect of the low-speed setting can be seen in slow to normal compression of the shock absorber.

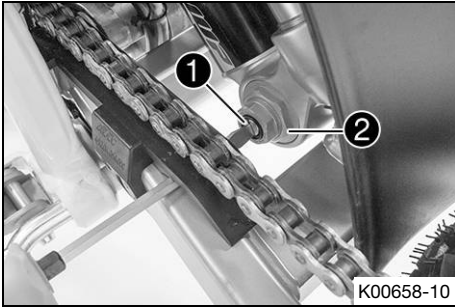

- Turn adjusting screw ① clockwise with a screwdriver up to the last perceptible click.

**Info**  
 Do not loosen fitting ②!

- Turn counterclockwise by the number of clicks corresponding to the shock absorber type.

Guideline

Compression damping, low-speed	
Comfort	18 clicks
Standard	15 clicks
Sport	12 clicks

**Info**  
 Turn clockwise to increase damping; turn counterclockwise to reduce damping.

## 10.5 Adjusting the high-speed compression damping of the shock absorber

**Caution**  
**Risk of injury** Parts of the shock absorber will fly off if the shock absorber is disassembled incorrectly. The shock absorber is filled with highly compressed nitrogen.

- Please follow the description provided. (Your authorized Husqvarna Motorcycles workshop will be glad to help.)

**Info**  
 The effect of the high-speed setting can be seen in fast compression of the shock absorber.

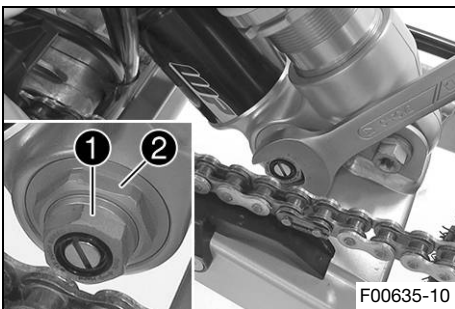

- Push splash protector to the side.
- Using an open end wrench, turn adjusting screw ① clockwise all the way.

**Info**  
 Do not loosen fitting ②!

- Turn counterclockwise by the number of turns corresponding to the shock absorber type.

Guideline

Compression damping, high-speed	
Comfort	2.5 turns
Standard	2 turns
Sport	1.5 turns

**Info**  
 Turn clockwise to increase damping; turn counterclockwise to reduce damping.

- Position the splash protector.

## 10.6 Adjusting the rebound damping of the shock absorber

**⚠ Caution**

**Risk of injury** Parts of the shock absorber will fly off if the shock absorber is disassembled incorrectly. The shock absorber is filled with highly compressed nitrogen.

- Please follow the description provided. (Your authorized Husqvarna Motorcycles workshop will be glad to help.)

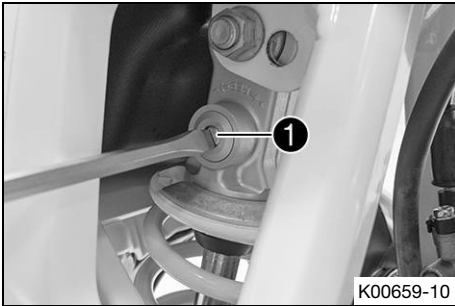

- Turn adjusting screw ① clockwise up to the last perceptible click.
- Turn counterclockwise by the number of clicks corresponding to the shock absorber type.

**Guideline**

Rebound damping	
Comfort	17 clicks
Standard	15 clicks
Sport	13 clicks

**i Info**

Turn clockwise to increase damping; turn counterclockwise to reduce damping.

## 10.7 Measuring rear wheel sag unloaded

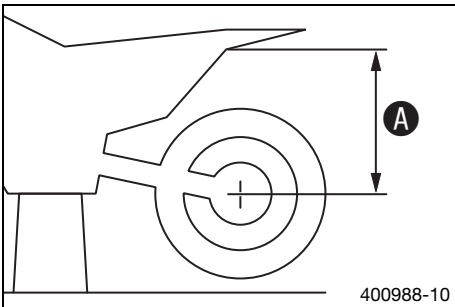

**Preparatory work**

- Raise the motorcycle with a lift stand. (📖 p. 30)

**Main work**

- Measure the distance – as vertical as possible – between the rear axle and a fixed point, for example, a mark on the side cover.
- Make a note of the value as measurement ①.

**Finishing work**

- Remove the motorcycle from the lift stand. (📖 p. 30)

## 10.8 Checking the static sag of the shock absorber

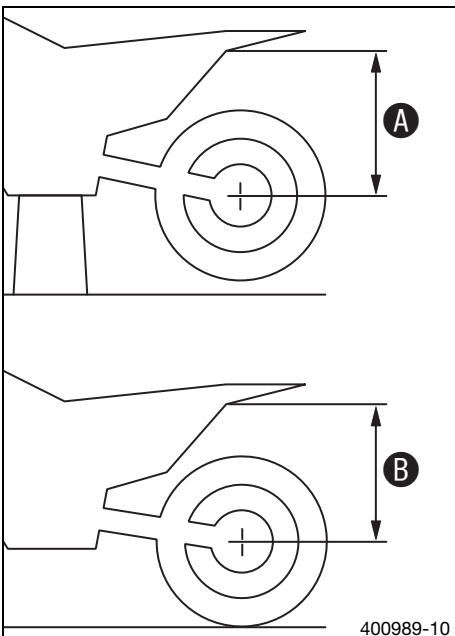

- Measure distance ① of rear wheel unloaded. (📖 p. 24)
- Hold the motorcycle upright with the aid of an assistant.
- Measure the distance between the rear axle and the fixed point again.
- Note down the value as dimension ②.

**i Info**

The static sag is the difference between measurements ① and ②.

- Check the static sag.

Static sag	12 mm (0.47 in)
------------	-----------------

- » If the static sag is less or more than the specified value:
  - Adjust the spring preload of the shock absorber. (📖 p. 25)

## 10.9 Checking the riding sag of the shock absorber

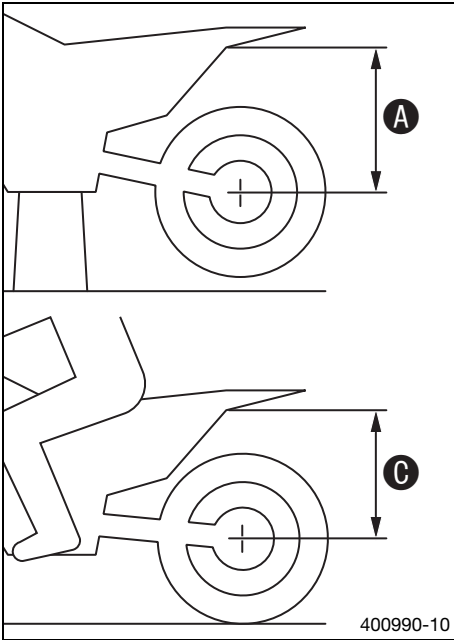

- Measure distance **A** of rear wheel unloaded. (📖 p. 24)
- With another person holding the motorcycle, the rider, wearing full protective clothing, sits on the seat in a normal sitting position (feet on footrests) and bounces up and down a few times.
  - ✓ The rear wheel suspension levels out.
- Another person now measures the distance between the rear axle and the fixed point.
- Note down the value as dimension **C**.

**i Info**

The riding sag is the difference between measurements **A** and **C**.

- Check the riding sag.

Riding sag	80 mm (3.15 in)
------------	-----------------

- » If the riding sag differs from the specified measurement:
  - Adjust the riding sag. 🛠️ (📖 p. 26)

## 10.10 Adjusting the spring preload of the shock absorber 🛠️

**⚠️ Caution**

**Risk of injury** Parts of the shock absorber will fly off if the shock absorber is disassembled incorrectly. The shock absorber is filled with highly compressed nitrogen.

- Please follow the description provided. (Your authorized Husqvarna Motorcycles workshop will be glad to help.)

**Preparatory work**

- Raise the motorcycle with a lift stand. (📖 p. 30)
- Remove the shock absorber. 🛠️ (📖 p. 41)
- After removing the shock absorber, clean it thoroughly.

**Main work**

- Measure the full spring length while it is under tension and note down the value.
- Loosen retaining ring **1**.
- Turn adjusting ring **2** until the spring is no longer under tension.

Hook wrench (T304)
Hook wrench (T1533)

- Measure the overall spring length while the spring is not under tension.
- Tighten the spring by turning adjusting ring **2** to measurement **A**.

**Guideline**

Spring preload	
Standard	3 mm (0.12 in)

**i Info**

The spring preload is the difference between the relaxed spring length and the tensioned spring length. Depending on the static sag and/or the riding sag, it may be necessary to increase or decrease the spring preload.

- Tighten retaining ring **1**.

**Finishing work**

- Install the shock absorber. 🛠️ (📖 p. 42)
- Remove the motorcycle from the lift stand. (📖 p. 30)

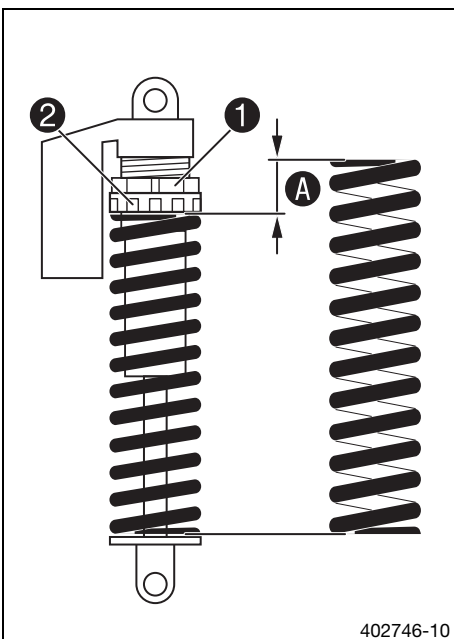

402746-10

## 10.11 Adjusting the riding sag 🛠️

### Preparatory work

- Raise the motorcycle with a lift stand. (📖 p. 30)
- Remove the shock absorber. 🛠️ (📖 p. 41)
- After removing the shock absorber, clean it thoroughly.

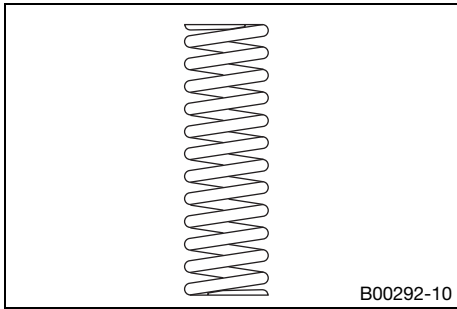

### Main work

- Choose and mount a suitable spring.

#### Guideline

Spring rate	
Weight of rider: 15... 25 kg (33... 55 lb.)	30 N/mm (171 lb/in)
Weight of rider (standard): 25... 35 kg (55... 77 lb.)	35 N/mm (200 lb/in)
Weight of rider: 35... 45 kg (77... 99 lb.)	40 N/mm (228 lb/in)



### Info

The spring rate is shown on the outside of the spring. Smaller weight differences can be compensated by changing the spring preload.

### Finishing work

- Install the shock absorber. 🛠️ (📖 p. 42)
- Remove the motorcycle from the lift stand. (📖 p. 30)
- Check the static sag of the shock absorber. (📖 p. 24)
- Check the riding sag of the shock absorber. (📖 p. 25)
- Adjust the rebound damping of the shock absorber. (📖 p. 24)

## 10.12 Checking the basic setting of the fork



### Info

For various reasons, no exact riding sag can be determined for the fork.

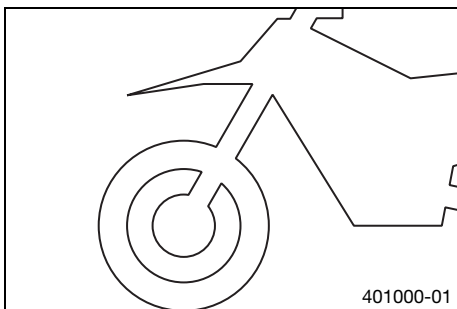

- Smaller differences in the rider's weight can be compensated for by the fork air pressure.
- However, if the fork frequently bottoms out (hard end stop on compression), the fork air pressure must be increased, within the specified values, to avoid damage to the fork and frame.

## 10.13 Adjusting the fork air pressure



### Warning

**Danger of accidents** Modifications to the suspension setting may seriously alter the handling characteristic.

Extreme modifications to the suspension setting may cause a serious deterioration in the handling characteristic and overload components.

- Only make adjustments within the recommended range.
- Make sure your child rides slowly to start with after making adjustments in order that he or she can assess the new handling characteristic.



### Info

Check or adjust the air pressure under the same conditions at the earliest 5 minutes after switching off the engine. The air suspension is located in the left fork leg. The rebound damping is located in the right fork leg.

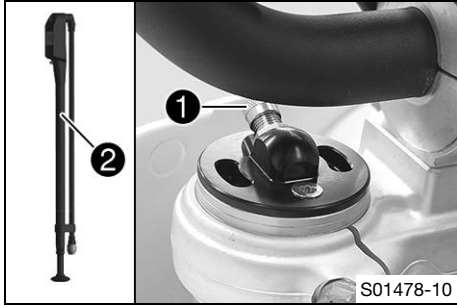

**Preparatory work**

- Raise the motorcycle with a lift stand. (📖 p. 30)

**Main work**

- Remove protection cap ①.
- Push fork pump ② together fully.

Fork pump (79412966000)

- Connect the fork pump to the left fork leg.
  - ✓ The fork pump indicator switches on automatically.
  - ✓ A little air escapes from the fork leg when connecting.

**i Info**  
This is due to the volume of the hose and not due to a defect in the fork pump or the fork.  
Read the accompanying instructions for Husqvarna Motorcycles accessories.

- Adjust the air pressure as specified.

**Guideline**

Air pressure	2 bar (29 psi)
Gradual changing of the air pressure in steps of	0.2 bar (3 psi)
Minimum air pressure	1.4 bar (20 psi)
Maximum air pressure	4 bar (58 psi)

**i Info**  
Never set the air pressure to a value outside the stated range.

- Disconnect the fork pump from the left fork leg.
  - ✓ When disconnecting, excess pressure will escape from the hose – the fork leg itself does not lose any air.
  - ✓ The fork pump indicator switches off automatically after 80 seconds.
- Mount the protection cap.

**Finishing work**

- Remove the motorcycle from the lift stand. (📖 p. 30)

**10.14 Adjusting the rebound damping of the fork**

**i Info**  
The hydraulic rebound damping determines the fork suspension behavior.



- Turn adjusting screw ① clockwise all the way.

**i Info**  
Adjusting screw ① is located at the upper end of the right fork leg.

- Turn counterclockwise by the number of clicks corresponding to the fork type.

**Guideline**

Rebound damping	
Comfort	15 clicks
Standard	12 clicks
Sport	10 clicks

**i Info**  
Turn clockwise to increase damping; turn counterclockwise to reduce damping.

## 10.15 Handlebar position

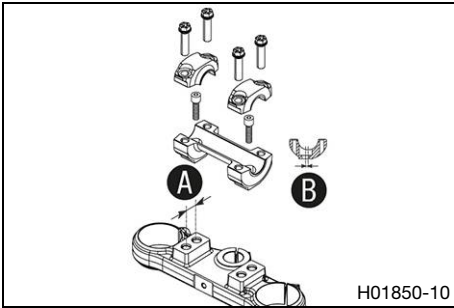

On the upper triple clamp, there are 2 holes at a distance of **A** to each other.

Hole distance <b>A</b>	15 mm (0.59 in)
------------------------	-----------------

The holes on the handlebar support are placed at a distance of **B** from the center.

Hole distance <b>B</b>	3.5 mm (0.138 in)
------------------------	-------------------

The handlebar holder can be mounted in four different positions. This allows the handlebar to be mounted in the most comfortable position for the rider.

## 10.16 Adjusting the handlebar position ↴



### Warning

**Danger of accidents** A repaired handlebar poses a safety risk.

If the handlebar is bent or straightened, the material becomes fatigued. The handlebar may break as a result.

- Change the handlebar if the handlebar is damaged or bent.

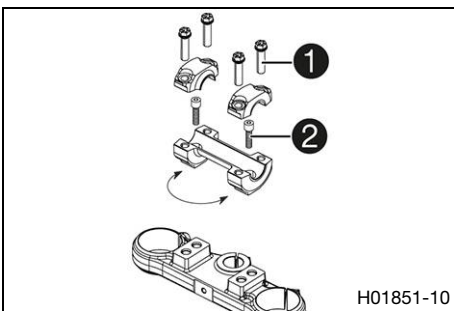

- Remove screws **1**. Take off the handlebar clamps. Remove the handlebar and lay it to one side.



### Info

Protect the motorcycle and its attachments against damage by covering them.

Do not kink the cables and lines.

- Remove screws **2**. Remove the handlebar support.
- Place the handlebar support in the required position. Mount and tighten screws **2**.

### Guideline

Screw, handlebar support	M10	40 Nm (29.5 lbf ft)	<b>Loctite® 243™</b>
--------------------------	-----	------------------------	----------------------

- Position the handlebar.



### Info

Make sure the cables and wiring are positioned correctly.

- Position the handlebar clamps. Mount screws **1** and tighten evenly.

### Guideline

Screw, handlebar clamp	M8	20 Nm (14.8 lbf ft)
------------------------	----	---------------------



### Info

Make sure the gap widths are even.

## 10.17 Adjusting the seat height ↴



### Warning

**Danger of accidents** Modifications to the suspension settings can seriously alter the vehicle's ride behavior.

- Following modifications, ride slowly at first to get the feel of the new ride behavior.

### Preparatory work

- Raise the motorcycle with a lift stand. (📖 p. 30)

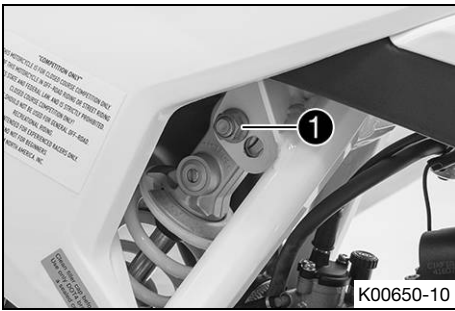

**Main work**

- Remove nut ①.

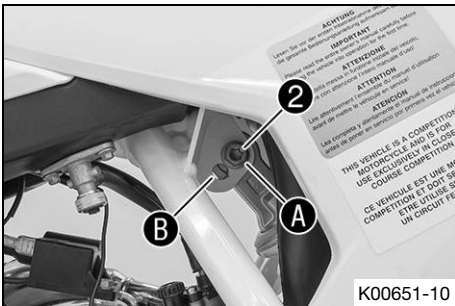

- Hold the rear wheel with the swingarm and remove screw ②.
- Position the shock absorber according to the required seat height.

**Guideline**

Low seat position (standard)	A
High seat position	B

- Position screw ②.



- Mount nut ① and tighten fitting.

**Guideline**

Screw, top shock absorber	M10	45 Nm (33.2 lbf ft)	<b>Loctite® 243™</b>
---------------------------	-----	------------------------	----------------------

**Finishing work**

- Remove the motorcycle from the lift stand. (📖 p. 30)

## 11.1 Raising the motorcycle with a lift stand

### Note

**Danger of damage** The parked vehicle can roll away or fall over.

- Park the vehicle on a firm and level surface.

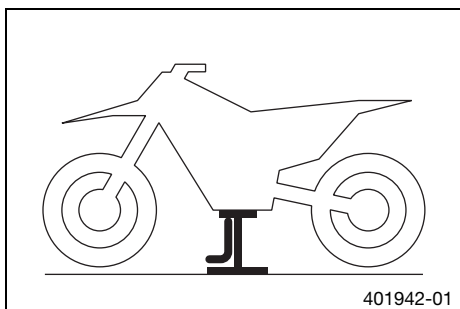

- Raise the motorcycle at the frame underneath the engine.

Lift stand (80329955100)

- ✓ Neither wheel is in contact with the ground.
- Secure the motorcycle against falling over.

## 11.2 Removing the motorcycle from the lift stand

### Note

**Danger of damage** The parked vehicle can roll away or fall over.

- Park the vehicle on a firm and level surface.

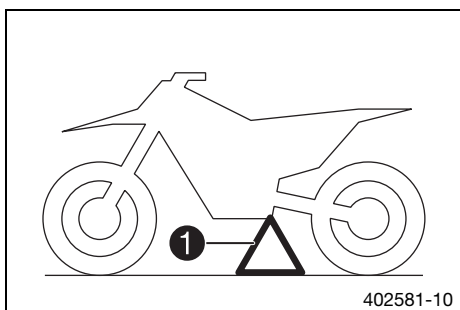

- Remove the motorcycle from the lift stand.
- Remove the lift stand.
- To park the motorcycle, insert plug-in stand ① into the plug-in stand bracket on the left side of the vehicle.



### Info

Remove the plug-in stand before riding.

## 11.3 Bleeding the fork legs

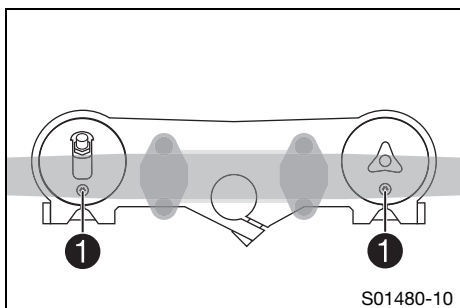

### Preparatory work

- Raise the motorcycle with a lift stand. (📖 p. 30)

### Main work

- Release bleeder screws ①.
- ✓ Any excess pressure escapes from the interior of the fork.
- Tighten the bleeder screws.

### Finishing work

- Remove the motorcycle from the lift stand. (📖 p. 30)



## 11.4 Cleaning the dust boots of the fork legs

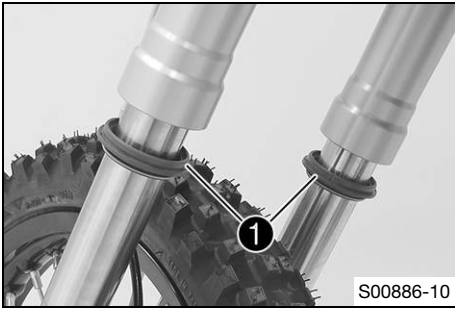

### Preparatory work

- Raise the motorcycle with a lift stand. (📖 p. 30)
- Remove the fork protector. (📖 p. 31)

### Main work

- Push dust boots ❶ of both fork legs downward.



### Info

The dust boots remove dust and coarse dirt particles from the inside fork tubes. Over time, dirt can accumulate behind the dust boots. If this dirt is not removed, the oil seals behind can start to leak.



### Warning

**Danger of accidents** Oil or grease on the brake discs reduces the braking effect.

- Always keep the brake discs free of oil and grease.
- Clean the brake discs with brake cleaner when necessary.

- Clean and oil the dust boots and inner fork tubes of both fork legs.

Universal oil spray (📖 p. 89)
-------------------------------

- Press the dust boots back into their installation position.
- Remove excess oil.

### Finishing work

- Install the fork protector. (📖 p. 31)
- Remove the motorcycle from the lift stand. (📖 p. 30)

## 11.5 Removing the fork protector



- Remove screws ❶ and take off the clamp.
- Remove screws ❷ on the left fork leg. Take off the fork protector.



- Remove screws ❸ on the right fork leg. Take off the fork protector.

## 11.6 Installing the fork protector



- Position the fork protector on the right fork leg. Mount and tighten screws ❶.

### Guideline

Remaining screws, chassis	M6	10 Nm (7.4 lbf ft)
---------------------------	----	--------------------



- Position the fork protector on the left fork leg. Mount and tighten screws ②.

Guideline

Remaining screws, chassis	M6	10 Nm (7.4 lbf ft)
---------------------------	----	--------------------

- Position the brake line and clamp. Mount and tighten screws ③.

## 11.7 Removing the fork legs

### Preparatory work

- Raise the motorcycle with a lift stand. (📖 p. 30)
- Remove the front wheel. (🔧 p. 65)

### Main work

- Remove screws ① and take off the clamp.
- Remove screws ② and take off the brake caliper.
- Allow the brake caliper and brake line to hang loosely to the side.



**i** Info

Do not kink the brake line.

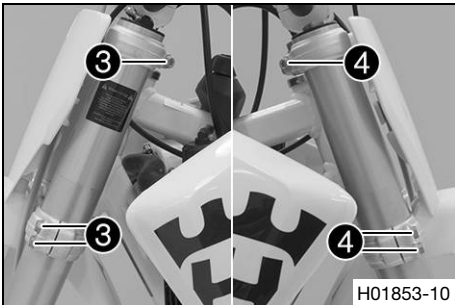

- Loosen screws ③. Remove the left fork leg.
- Loosen screws ④. Remove the right fork leg.

## 11.8 Installing the fork legs

### Main work

- Position the fork legs.
- ✓ Bleeder screws ① are positioned toward the rear.

**i** Info

The second milled groove (from the top) must be flush with the top edge of the upper triple clamp.

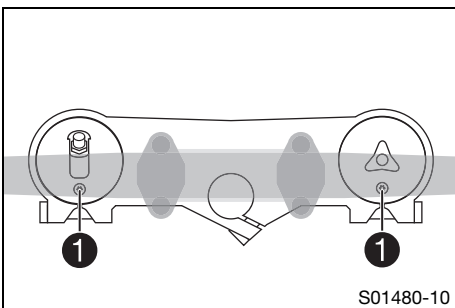

- Tighten screws ②.

Guideline

Screw, top triple clamp	M8	20 Nm (14.8 lbf ft)
-------------------------	----	---------------------

- Tighten screws ③.

Guideline

Screw, bottom triple clamp	M8	15 Nm (11.1 lbf ft)
----------------------------	----	---------------------

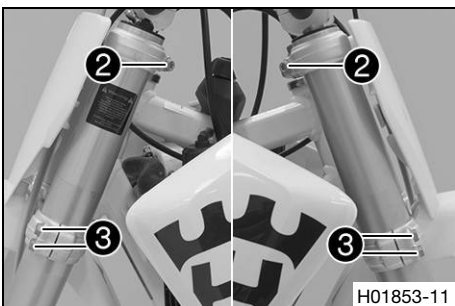

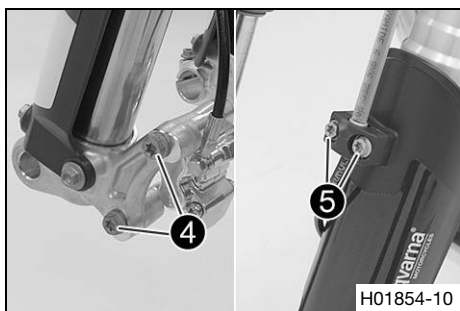

- Position the brake caliper, and mount and tighten screws **4**.

Guideline

Screw, front brake caliper	M8	20 Nm (14.8 lbf ft)	Loctite® 243™
----------------------------	----	------------------------	---------------

- Position the brake line and clamp. Mount and tighten screws **5**.

**Finishing work**

- Install the front wheel. 🛠️ (📖 p. 65)

## 11.9 Removing the lower triple clamp 🛠️

**Preparatory work**

- Raise the motorcycle with a lift stand. (📖 p. 30)
- Remove the front wheel. 🛠️ (📖 p. 65)
- Remove the fork legs. 🛠️ (📖 p. 32)
- Remove the start number plate. (📖 p. 36)
- Dismount the front fender. (📖 p. 37)

**Main work**

- Pull fuel tank breather **1** out of the steering stem.
- Remove nut **2**, loosen screw **3**, take off the upper triple clamp with the handlebar, and place it to one side.

**i Info**

Cover the components to protect them against damage. Do not kink the cables and lines.

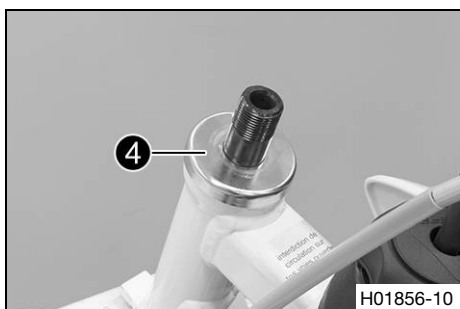
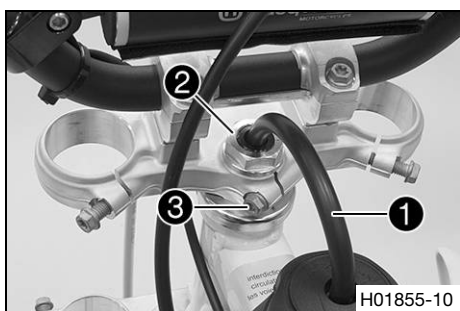

- Remove protective ring **4**.
- Remove the lower triple clamp with the steering stem.
- Remove the upper steering head bearing.

## 11.10 Installing the lower triple clamp

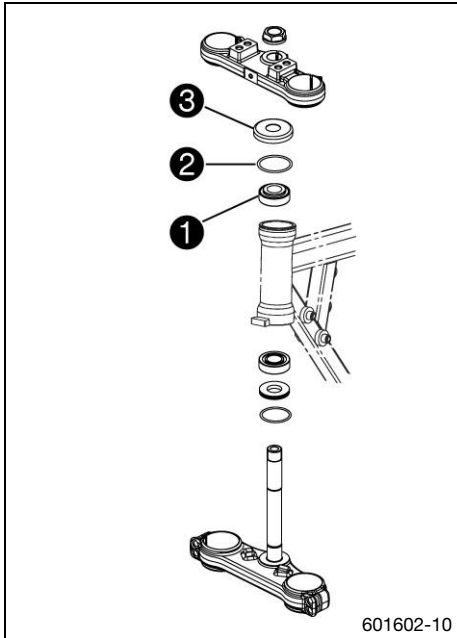

### Main work

- Clean the bearing and sealing elements, check for damage, and grease.

High viscosity grease (p. 89)

- Insert the lower triple clamp with the steering stem. Mount upper steering head bearing **1**.
- Check whether upper steering head seal **2** is correctly positioned.
- Push on protective ring **3**.

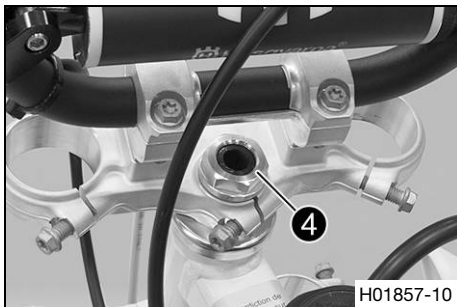

- Position the upper triple clamp with the handlebar.
- Mount nut **4**, but do not tighten it yet.

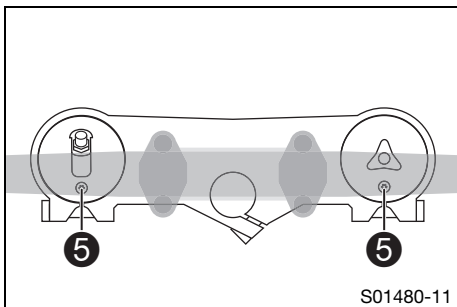

- Position the fork legs.
- ✓ Bleeder screws **5** are positioned toward the rear.

### Info

The second milled groove (from the top) must be flush with the top edge of the upper triple clamp.

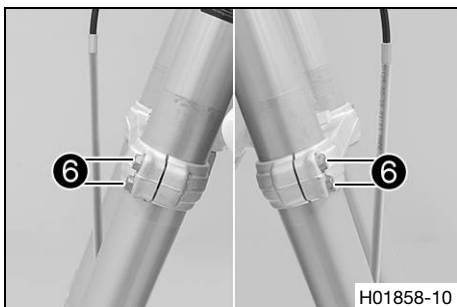

- Tighten screws **6**.

### Guideline

Screw, bottom triple clamp	M8	15 Nm (11.1 lbf ft)
----------------------------	----	---------------------

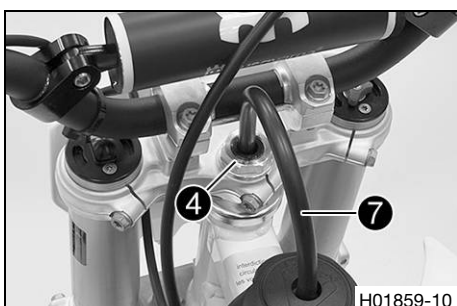

- Tighten nut **4**.

### Guideline

Nut, steering head	M20x1.5	10 Nm (7.4 lbf ft)	-
Nut, steering head	M20x1.5	9 Nm (6.6 lbf ft)	Only applies when using: Holding wrench for steering head bearing (45229050000)

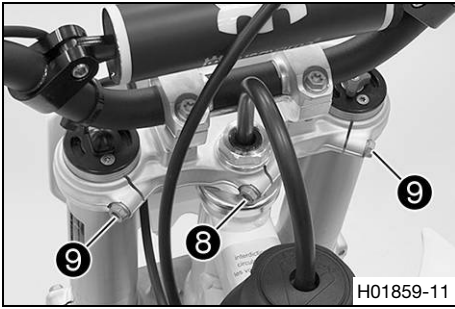

- Position the fuel tank breather 7 in the steering stem.
- Tighten screw 8.

Guideline

Screw, top triple clamp	M8	20 Nm (14.8 lbf ft)
-------------------------	----	---------------------

- Using a plastic hammer, tap lightly on the upper triple clamp to avoid stresses.
- Tighten screws 9.

Guideline

Screw, top triple clamp	M8	20 Nm (14.8 lbf ft)
-------------------------	----	---------------------

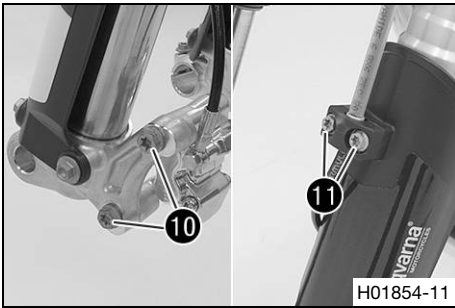

- Position the brake caliper, and mount and tighten screws 10.

Guideline

Screw, front brake caliper	M8	20 Nm (14.8 lbf ft)	Loctite® 243™
----------------------------	----	---------------------	---------------

- Position the brake line and clamp. Mount and tighten screws 11.

### Finishing work

- Install the front fender. (📖 p. 37)
- Install the start number plate. (📖 p. 37)
- Check that the wiring harness, throttle cables, and brake and clutch lines can move freely and are routed correctly.
- Install the front wheel. 🛠️ (📖 p. 65)
- Check play of steering head bearing. (📖 p. 35)
- Remove the motorcycle from the lift stand. (📖 p. 30)

## 11.11 Checking play of steering head bearing

**Warning**  
**Danger of accidents** Incorrect steering head bearing play impairs the handling characteristic and damages components.

- Correct incorrect steering head bearing play immediately. (Your authorized Husqvarna Motorcycles workshop will be glad to help.)

**Info**  
 If the bike is ridden with play in the steering head bearing, the bearing and the bearing seats in the frame can become damaged over time.

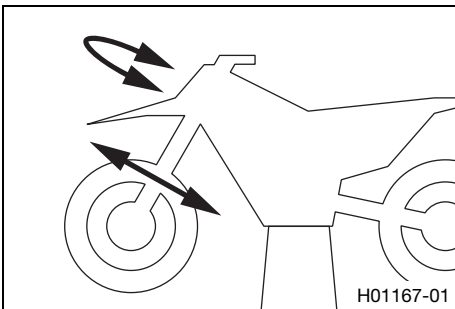

### Preparatory work

- Raise the motorcycle with a lift stand. (📖 p. 30)

### Main work

- Move the handlebar to the straight-ahead position. Move the fork legs to and fro in the direction of travel.

No play should be noticeable in the steering head bearing.

» If there is noticeable play present:

- Adjust the steering head bearing play. 🛠️ (📖 p. 36)

- Move the handlebar to and fro over the entire steering range.

The handlebar must be able to move easily over the entire steering range. No resting locations should be noticeable.

» If click positions are noticeable:

- Adjust the steering head bearing play. 🛠️ (📖 p. 36)
- Check the steering head bearing and replace if required.

### Finishing work

- Remove the motorcycle from the lift stand. (📖 p. 30)

## 11.12 Adjusting the steering head bearing play

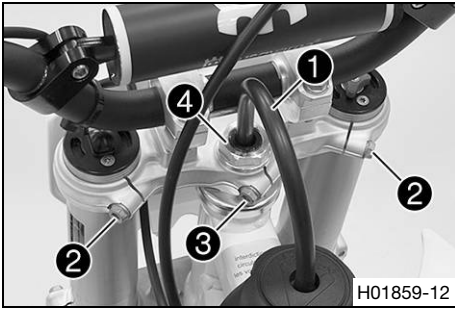

### Preparatory work

- Raise the motorcycle with a lift stand. (p. 30)

### Main work

- Pull fuel tank breather ① out of the steering stem.
- Loosen screws ②.
- Loosen screw ③.
- Loosen and retighten nut ④.

#### Guideline

Nut, steering head	M20x1.5	10 Nm (7.4 lbf ft)	-
Nut, steering head	M20x1.5	9 Nm (6.6 lbf ft)	Only applies when using: Holding wrench for steering head bearing (45229050000)

- Using a plastic hammer, tap lightly on the upper triple clamp to avoid stresses.
- Tighten screw ③.

#### Guideline

Screw, top triple clamp	M8	20 Nm (14.8 lbf ft)
-------------------------	----	---------------------

- Tighten screws ②.

#### Guideline

Screw, top triple clamp	M8	20 Nm (14.8 lbf ft)
-------------------------	----	---------------------

- Position the fuel tank breather ① in the steering stem.

### Finishing work

- Check play of steering head bearing. (p. 35)
- Remove the motorcycle from the lift stand. (p. 30)

## 11.13 Greasing the steering head bearing

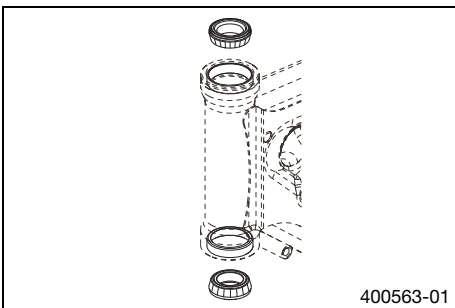

- Remove the lower triple clamp. (p. 33)
- Install the lower triple clamp. (p. 34)

## 11.14 Removing the start number plate

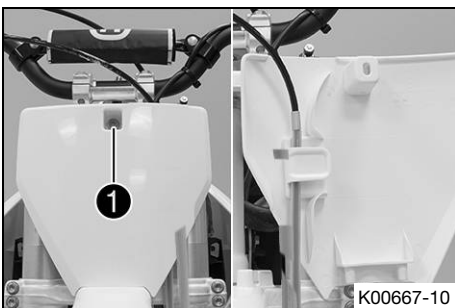

- Remove screw ①.
- Unhook the start number plate from the brake line and remove it.

## 11.15 Installing the start number plate

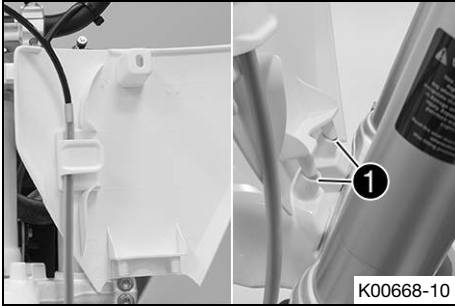

K00668-10

- Attach the start number plate to the brake line.
- Position the start number plate.
- ✓ Holding lugs ① engage in the fender.

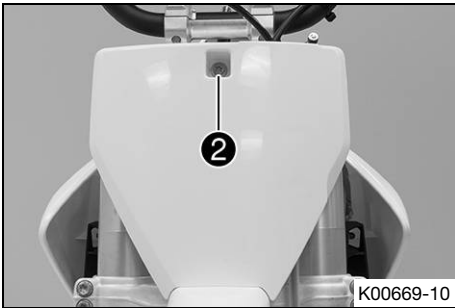

K00669-10

- Mount and tighten screw ②.

Guideline

Screw, start number plate	M6	4 Nm (3 lbf ft)
---------------------------	----	-----------------

## 11.16 Dismounting the front fender

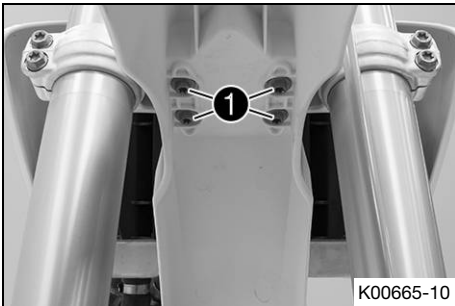

K00665-10

- Remove screws ①. Remove the front fender.

## 11.17 Installing the front fender

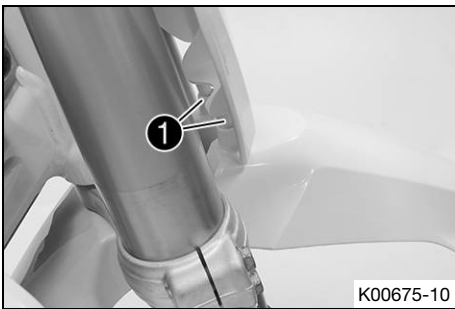

K00675-10

- Position the fender with drill holes ① in the holding lugs on the start number plate.

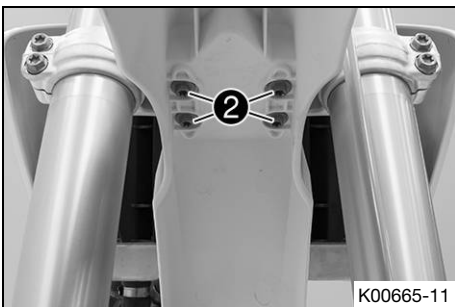

K00665-11

- Position the front fender. Mount and tighten screws ②.

Guideline

Screw, fender	M6	6 Nm (4.4 lbf ft)
---------------	----	-------------------

## 11.18 Removing the right side cover

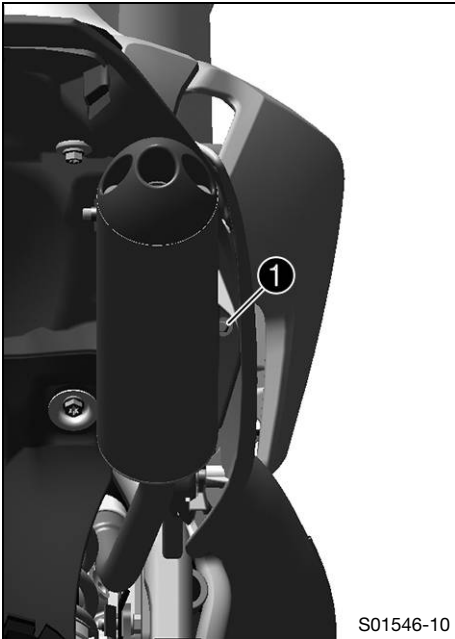

S01546-10

### Preparatory work

- Remove the seat. (📖 p. 42)

### Condition

Right side cover secured.

- Remove screw ①.

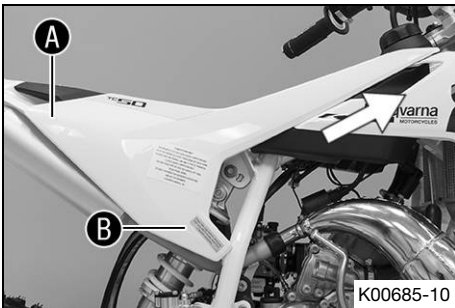

K00685-10

- Pull off the side cover sideways in areas ① and ②, and remove toward the front.

## 11.19 Installing the right side cover

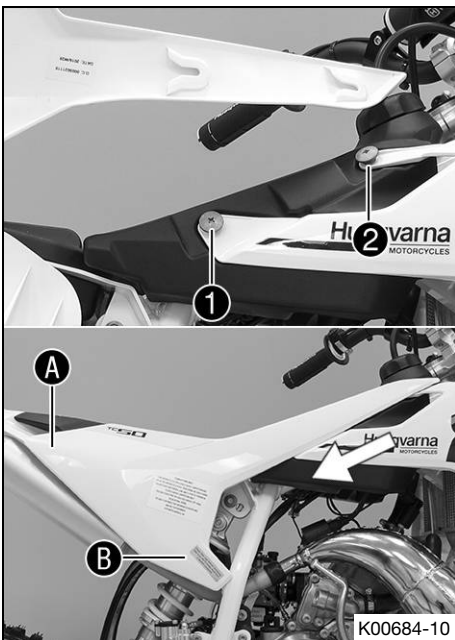

K00684-10

### Main work

- Position the side cover on collar bushings ① and ②, and push toward the rear.
- Engage the side cover in areas ① and ②.



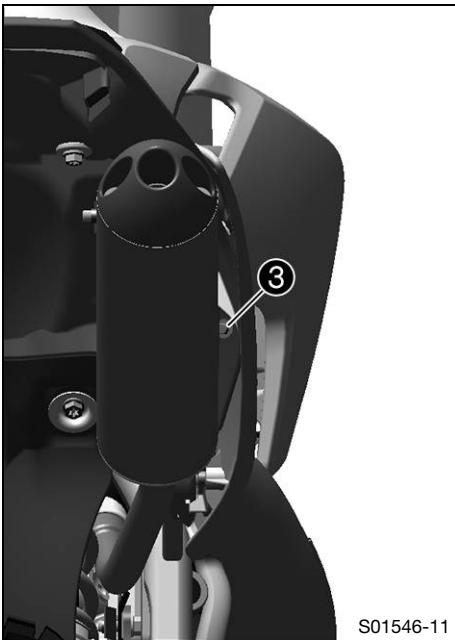

**Condition**

Right side cover secured.

- Mount and tighten screw ③.

Guideline

Screw, side cover	EJOT PT® K60x20-Z	2 Nm (1.5 lbf ft)
-------------------	----------------------	-------------------

**Finishing work**

- Mount the seat. (📖 p. 43)

## 11.20 Securing right side cover 🛠️

**Preparatory work**

- Remove the seat. (📖 p. 42)
- Remove the right side cover. (📖 p. 38)

**Main work**

- Drill a hole at marking A.

Guideline

Diameter	6.5 mm (0.256 in)
----------	-------------------

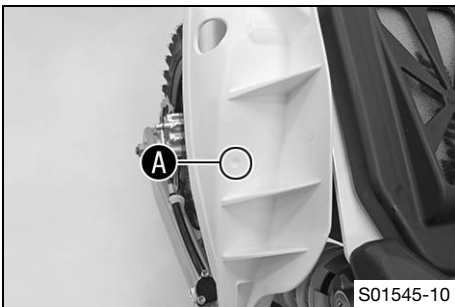

**Finishing work**

- Install the right side cover. (📖 p. 38)
- Mount the seat. (📖 p. 43)

## 11.21 Removing the left side cover

**Preparatory work**

- Remove the seat. (📖 p. 42)

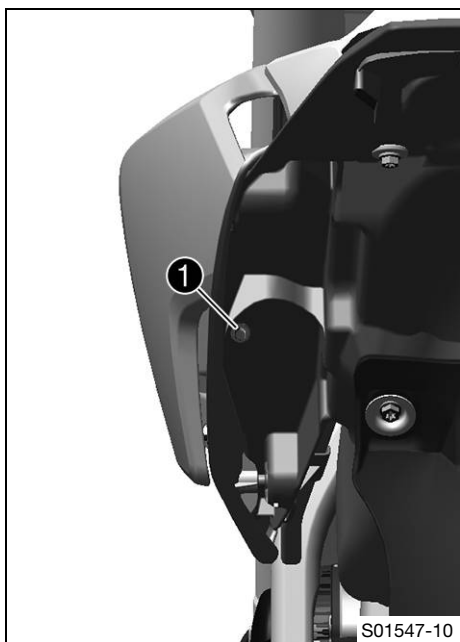

### Condition

Left side cover secured.

- Remove screw ①.

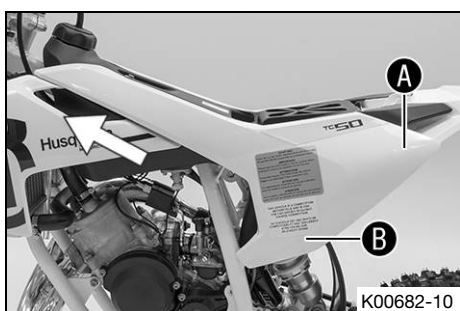

- Pull off the side cover sideways in areas ① and ②, and remove toward the front.

## 11.22 Installing the left side cover

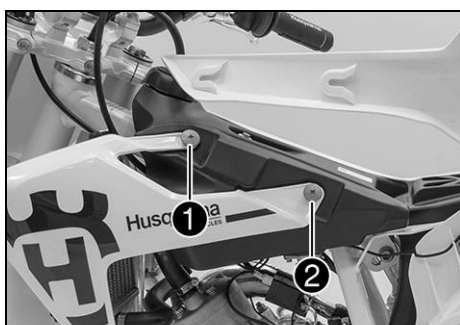

### Main work

- Position the side cover on collar bushings ① and ②, and push toward the rear.
- Engage the side cover in areas ① and ②.



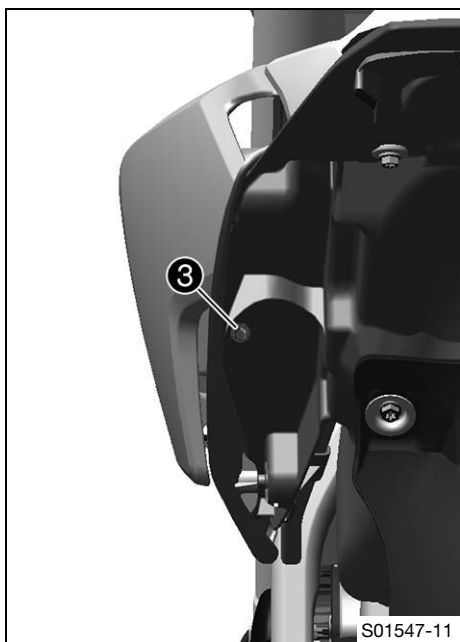

S01547-11

**Condition**

Left side cover secured.

- Mount and tighten screw ③.

**Guideline**

Screw, side cover	<b>EJOT PT®</b> K60x20-Z	2 Nm (1.5 lbf ft)
-------------------	-----------------------------	-------------------

**Finishing work**

- Mount the seat. (📖 p. 43)

## 11.23 Securing left side cover 🛠️

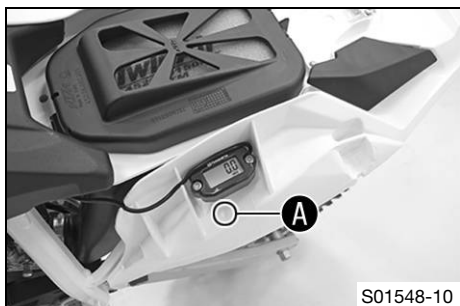

S01548-10

**Preparatory work**

- Remove the seat. (📖 p. 42)
- Remove the left side cover. (📖 p. 39)

**Main work**

- Drill a hole at marking A.

**Guideline**

Diameter	6.5 mm (0.256 in)
----------	-------------------

**Finishing work**

- Install the left side cover. (📖 p. 40)
- Mount the seat. (📖 p. 43)

## 11.24 Removing the shock absorber 🛠️

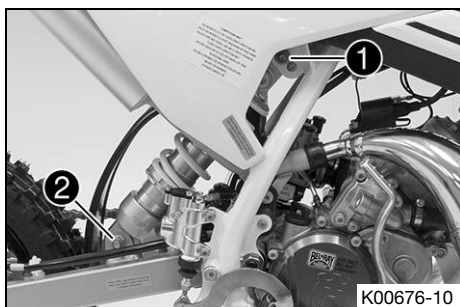

K00676-10

**Preparatory work**

- Raise the motorcycle with a lift stand. (📖 p. 30)

**Main work**

- Remove nut ① and ②.

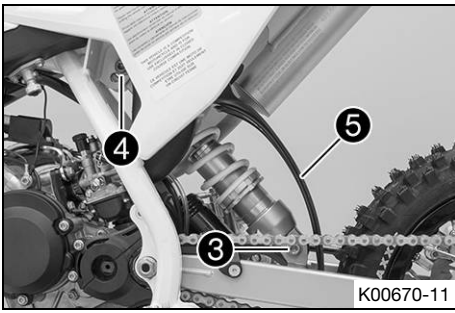

- Remove screw ③ and lower the rear wheel with the swingarm as far as possible without blocking the rear wheel. Secure the rear wheel in this position.
- Remove screw ④, push splash protector ⑤ to the side, and remove the shock absorber.

## 11.25 Installing the shock absorber ↩



### Warning

**Danger of accidents** Modifications to the suspension settings can seriously alter the vehicle's ride behavior.

- Following modifications, ride slowly at first to get the feel of the new ride behavior.

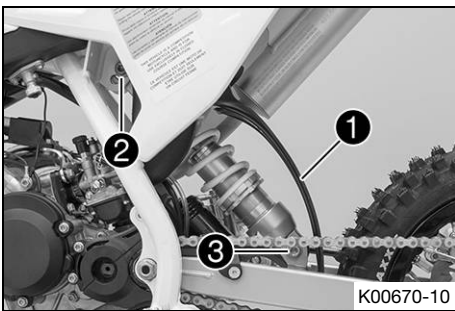

### Main work

- Push splash protector ① to the side.
- Position the shock absorber with screw ②, depending on the desired seating height.
- Raise the swingarm; position the shock absorber with screw ③.

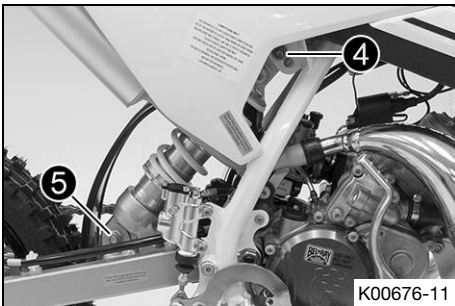

- Mount nut ④ and tighten fitting.

Guideline

Screw, top shock absorber	M10	45 Nm (33.2 lbf ft)	Loctite® 243™
---------------------------	-----	------------------------	---------------

- Mount nut ⑤ and tighten fitting.

Guideline

Screw, bottom shock absorber	M10	45 Nm (33.2 lbf ft)	Loctite® 243™
------------------------------	-----	------------------------	---------------

### Finishing work

- Remove the motorcycle from the lift stand. (📖 p. 30)

## 11.26 Removing the seat

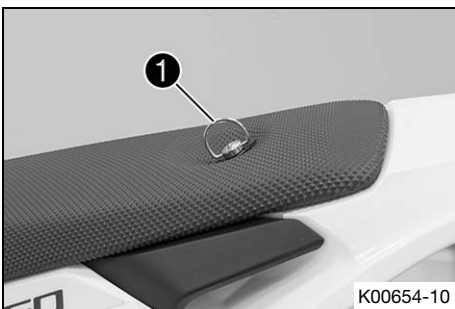

- Open quick release ① and raise the rear of the seat.
- Pull back the seat and remove it.

## 11.27 Mounting the seat

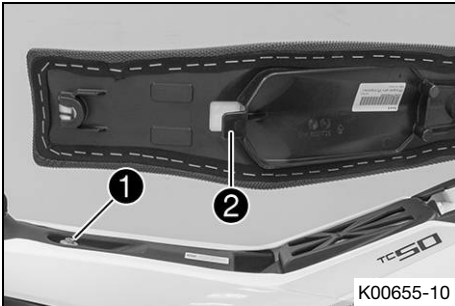

- Hook the seat onto screw **1**, lower the seat at the rear, and push it forward.
- ✓ Catch **2** hooks into the fuel tank.

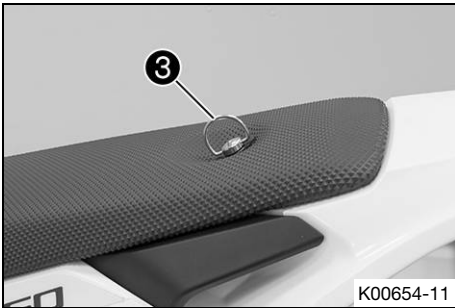

- Close quick release **3**.

## 11.28 Removing the air filter

### Note

**Engine damage** Unfiltered intake air has a negative effect on the service life of the engine. Dust and dirt will enter the engine without an air filter.

- Never start to use the vehicle without an air filter.



### Warning

**Environmental hazard** Hazardous substances cause environmental damage.

- Dispose of oils, grease, filters, fuel, cleaning agents, brake fluid, etc., correctly and in compliance with the applicable regulations.

### Preparatory work

- Remove the seat. (📖 p. 42)

### Main work

- Press the rear holding lugs **1** together slightly and swing the air filter box cover upward. Pull out the front holding lug and take off the air filter box cover.
- Take off the air filter.



## 11.29 Installing the air filter

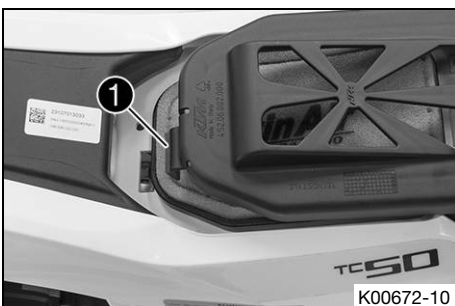

### Main work

- Position the clean air filter.
- Position the rear holding lug. Lower the air filter box cover and allow the front holding lug **1** to snap in.



### Info

If the air filter is not correctly mounted, dust and dirt can enter the engine and cause damage.

### Finishing work

- Mount the seat. (📖 p. 43)

## 11.30 Cleaning the air filter and air filter box

### Warning

**Environmental hazard** Hazardous substances cause environmental damage.

- Dispose of oils, grease, filters, fuel, cleaning agents, brake fluid, etc., correctly and in compliance with the applicable regulations.

### Info

Do not clean the air filter with fuel or petroleum since these substances attack the foam.

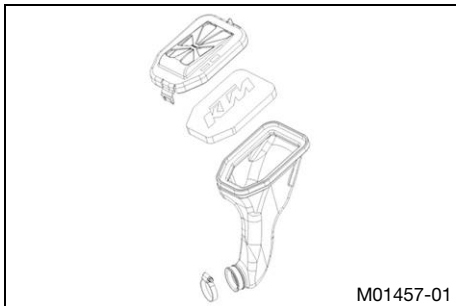

#### Preparatory work

- Remove the seat. (📖 p. 42)
- Remove the air filter. (🔧 p. 43)

#### Main work

- Wash the air filter thoroughly in special cleaning liquid and allow it to dry properly.

Air filter cleaning agent (📖 p. 89)

### Info

Only press the air filter to dry it, never wring it out.

- Oil the dry air filter with a high quality filter oil.

Oil for foam air filter (📖 p. 89)

- Clean the air filter box.
- Check the intake flange for damage and looseness.

#### Finishing work

- Install the air filter. (🔧 p. 43)
- Mount the seat. (📖 p. 43)

## 11.31 Removing the main silencer

### Warning

**Danger of burns** The exhaust system gets very hot when the vehicle is driven.

- Allow the exhaust system to cool down before performing any work on the vehicle.

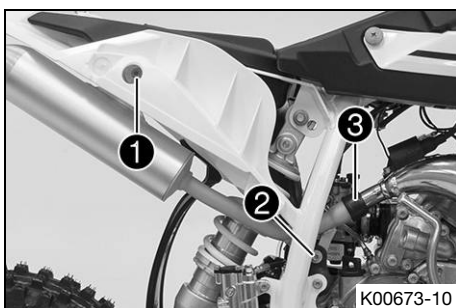

#### Preparatory work

- Remove the seat. (📖 p. 42)
- Remove the right side cover. (📖 p. 38)

#### Main work

- Remove screw ①.
- Remove screw ②.
- Pull off the main silencer from the manifold at rubber sleeve ③.

## 11.32 Installing the main silencer

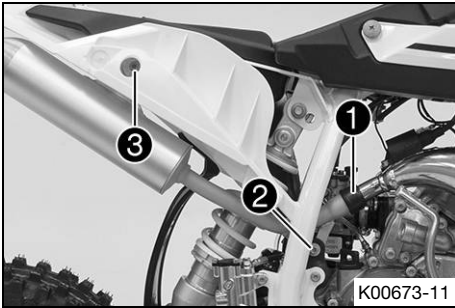

### Main work

- Mount the main silencer with rubber sleeve ①.
- Mount the silent block with screw ②.

#### Guideline

Remaining screws, chassis	M6	10 Nm (7.4 lbf ft)
---------------------------	----	--------------------

- Position the collar bushings.
- Mount and tighten screw ③.

#### Guideline

Remaining screws, chassis	M6	10 Nm (7.4 lbf ft)
---------------------------	----	--------------------

### Finishing work

- Install the right side cover. (📖 p. 38)
- Mount the seat. (📖 p. 43)

## 11.33 Changing the glass fiber yarn filling of the main silencer ↗



### Warning

**Danger of burns** The exhaust system gets very hot when the vehicle is driven.

- Allow the exhaust system to cool down before performing any work on the vehicle.



### Info

Over time, the fibers of the glass fiber yarn escape and the damper "burns" out. Not only is the noise level higher, the performance characteristic changes.

### Preparatory work

- Remove the seat. (📖 p. 42)
- Remove the right side cover. (📖 p. 38)
- Remove the main silencer. (📖 p. 44)

### Main work

- Remove screws with toothed washers ① from the silencer cap ②.
- Remove end cap and outer tube ③.
- Remove glass fiber yarn filling ④ from the inner tube.
- Clean the parts that need to be reinstalled and check for damage.
- Mount the new glass fiber yarn filling on the inner tube.
- Slide the outer tube over the glass fiber yarn filling.
- Insert the end cap into the outer tube.
- Mount and tighten the screws with the toothed washers.

#### Guideline

Remaining screws, chassis	M6	10 Nm (7.4 lbf ft)
---------------------------	----	--------------------

### Finishing work

- Install the main silencer. (📖 p. 45)
- Install the right side cover. (📖 p. 38)
- Mount the seat. (📖 p. 43)

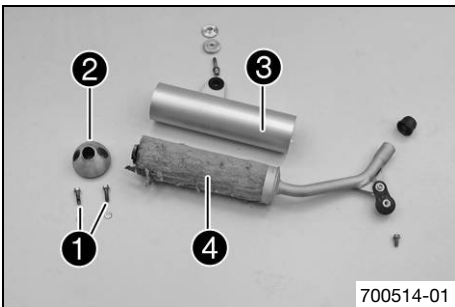

## 11.34 Removing the engine sprocket cover ↴

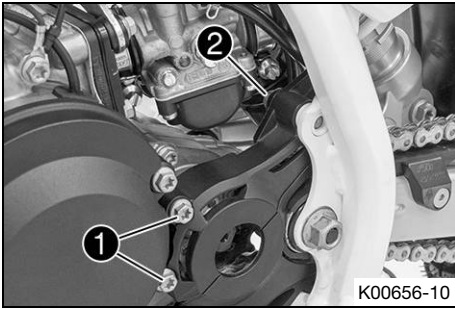

K00656-10

### Preparatory work

- Raise the motorcycle with a lift stand. (📖 p. 30)

### Main work

- Remove screws ①.
- Remove screw ②.
- Take off the engine sprocket cover.

## 11.35 Installing the engine sprocket cover ↴

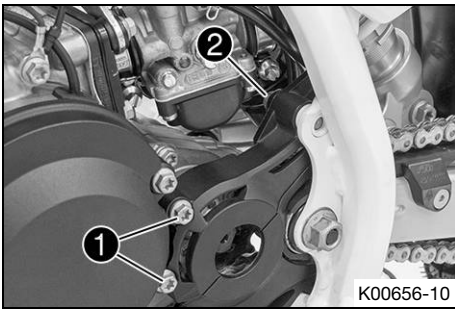

K00656-10

### Main work

- Position the engine sprocket cover. Mount screws ① but do not tighten yet.
- Mount and tighten screw ②.

#### Guideline

Screw, engine sprocket cover	M8	12 Nm (8.9 lbf ft)
------------------------------	----	--------------------

- Tighten screws ①.

#### Guideline

Screw, engine sprocket cover	M6	10 Nm (7.4 lbf ft)
------------------------------	----	--------------------

### Finishing work

- Remove the motorcycle from the lift stand. (📖 p. 30)

## 11.36 Checking the chain for dirt

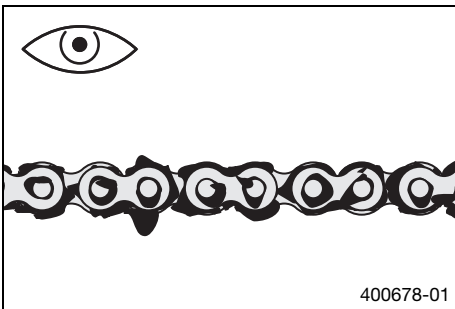

400678-01

- Check the chain for coarse dirt accumulation.
  - » If the chain is very dirty:
    - Clean the chain. (📖 p. 46)

## 11.37 Cleaning the chain



### Warning

**Danger of accidents** Oil or grease on the tires reduces the road grip.

- Remove the lubricant from the tires using a suitable cleaning agent.



### Warning

**Danger of accidents** Oil or grease on the brake discs reduces the braking effect.

- Always keep the brake discs free of oil and grease.
- Clean the brake discs with brake cleaner when necessary.



### Warning

**Environmental hazard** Hazardous substances cause environmental damage.

- Dispose of oils, grease, filters, fuel, cleaning agents, brake fluid, etc., correctly and in compliance with the applicable regulations.



### Info

The service life of the chain depends largely on its maintenance.



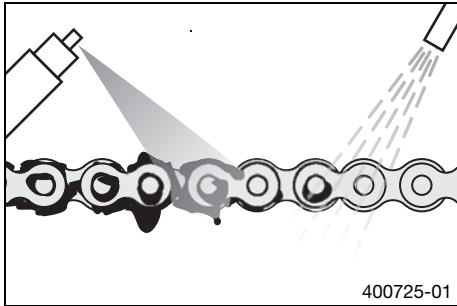

### Preparatory work

- Raise the motorcycle with a lift stand. (📖 p. 30)

### Main work

- Clean the chain regularly and then treat with chain spray.

Offroad chain spray (📖 p. 89)

### Finishing work

- Remove the motorcycle from the lift stand. (📖 p. 30)

## 11.38 Checking the chain tension

### Warning

**Danger of accidents** Incorrect chain tension damages components and results in accidents.

If the chain is tensioned too much, the chain, engine sprocket, rear sprocket, transmission and rear wheel bearings wear more quickly. Some components may break if overloaded.

If the chain is too loose, the chain may fall off the engine sprocket or the rear sprocket. As a result, the rear wheel locks or the engine will be damaged.

- Check the chain tension regularly.
- Set the chain tension in accordance with the specification.

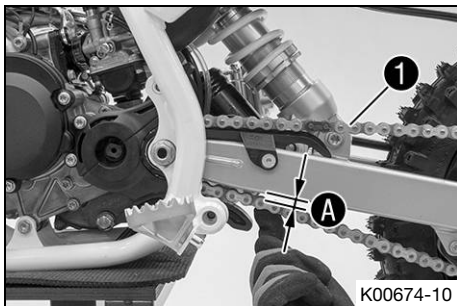

### Preparatory work

- Raise the motorcycle with a lift stand. (📖 p. 30)

### Main work

- Press the chain upward at the end of the chain sliding piece and determine chain tension **A**.

### Info

The upper part of the chain **1** must be taut.

Chain wear is not always even, so you should repeat this measurement at different chain positions.

Chain tension	5... 8 mm (0.2... 0.31 in)
---------------	----------------------------

- » If the chain tension does not meet the specification:
  - Adjust the chain tension. (📖 p. 47)

### Finishing work

- Remove the motorcycle from the lift stand. (📖 p. 30)

## 11.39 Adjusting the chain tension

### Warning

**Danger of accidents** Incorrect chain tension damages components and results in accidents.

If the chain is tensioned too much, the chain, engine sprocket, rear sprocket, transmission and rear wheel bearings wear more quickly. Some components may break if overloaded.

If the chain is too loose, the chain may fall off the engine sprocket or the rear sprocket. As a result, the rear wheel locks or the engine will be damaged.

- Check the chain tension regularly.
- Set the chain tension in accordance with the specification.

### Preparatory work

- Raise the motorcycle with a lift stand. (📖 p. 30)
- Check the chain tension. (📖 p. 47)

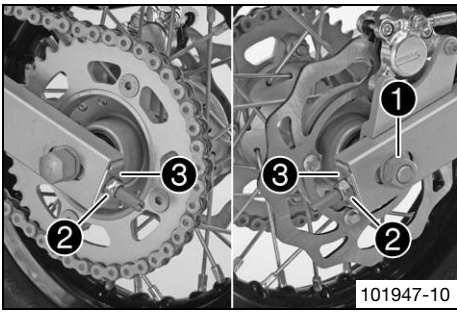

**Main work**

- Loosen nut ①.
- Adjust the chain tension by turning adjusting nuts ② left and right.

Guideline

Chain tension	5... 8 mm (0.2... 0.31 in)
Turn adjusting nuts ② equally on the left and right. The rear wheel must be aligned with the front wheel.	

- Make sure that the chain adjuster support plates ③ are in contact with adjusting nuts ②.
- Tighten nut ①.

Guideline

Nut, rear wheel spindle	M12x1	40 Nm (29.5 lbf ft)
-------------------------	-------	---------------------

## 11.40 Checking the chain, rear sprocket, engine sprocket and chain guide

**Preparatory work**

- Raise the motorcycle with a lift stand. (📖 p. 30)
- Remove the engine sprocket cover. 🛠️ (📖 p. 46)

**Main work**

- Check the engine sprocket cover for wear.
  - » If the engine sprocket cover is worn through in the marked area A:
    - Change the engine sprocket cover. 🛠️

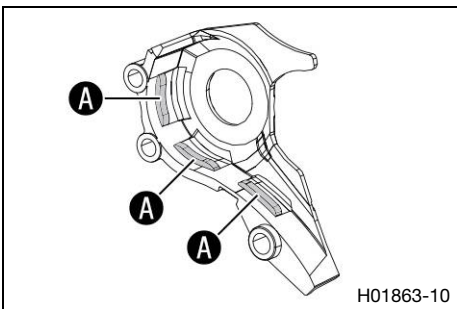

- Check the rear sprocket and engine sprocket for wear.
  - » If the rear sprocket or engine sprocket is worn:
    - Change the drivetrain kit. 🛠️

---

**i Info**  
 The engine sprocket, rear sprocket, and chain should always be replaced together.  
 When fitting the chain joint, always make sure that the closed side of the joint faces forward (riding direction).

---

- Check the chain for wear.
  - » If the chain is worn:
    - Change the drivetrain kit. 🛠️

---

**i Info**  
 When a new chain is mounted, the rear sprocket and engine sprocket should also be changed.  
 New chains wear out faster on old, worn sprockets.

---

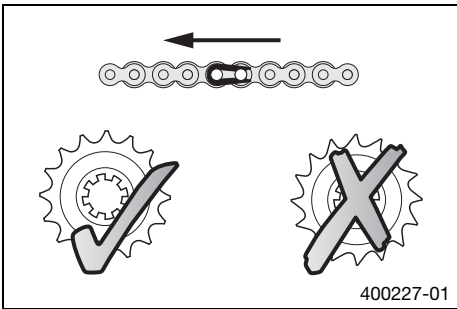

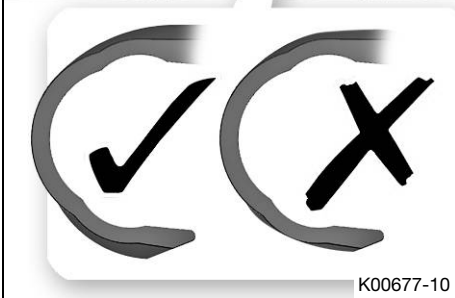
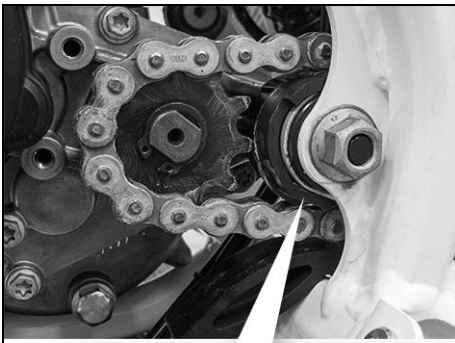

K00677-10

- Check the chain sliding guard for wear.
  - » If the ridge is worn down to the level of the main corpus:
    - Change the chain sliding guard. 🛠️
- Check that the chain sliding guard is firmly seated.
  - » If the chain sliding guard is loose:
    - Tighten the screw of the chain sliding guard.

Guideline

Screw, chain sliding piece	M6	3 Nm (2.2 lbf ft)
----------------------------	----	-------------------

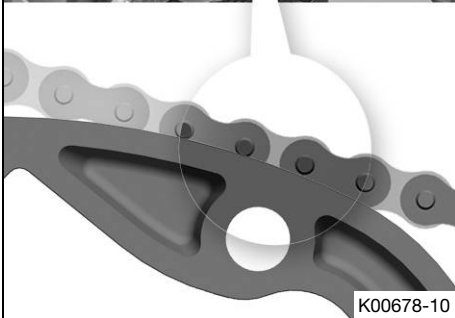
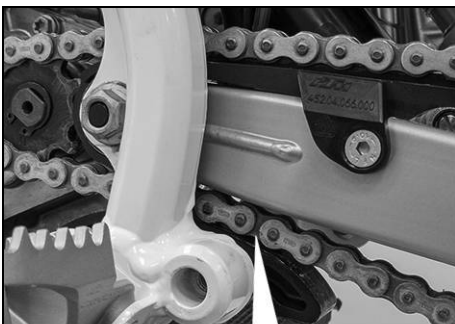

K00678-10

- Check the chain sliding piece for wear.
  - » If the lower edge of the chain pins is in line with or below the chain sliding piece:
    - Change the chain sliding piece. 🛠️
- Check that the chain sliding piece is firmly seated.
  - » If the chain sliding piece is loose:
    - Tighten the screw on the chain sliding piece.

Guideline

Screw, chain sliding piece	M8	15 Nm (11.1 lbf ft)
----------------------------	----	------------------------

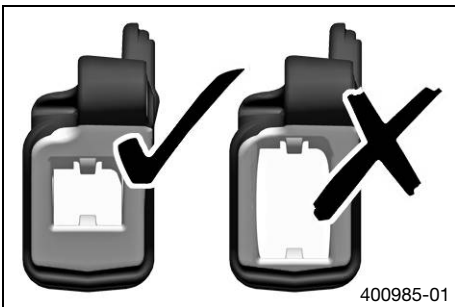

400985-01

- Check the chain guide for wear.

**i Info**

Wear can be seen on the front of the chain guide.

- » If the light part of the chain guide is worn:
  - Change the chain guide. 🛠️

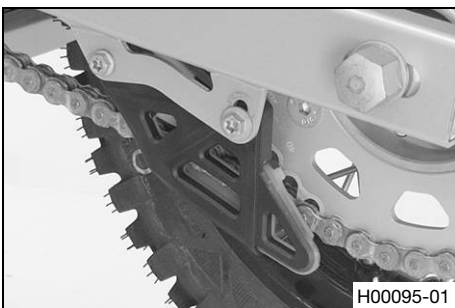

H00095-01

- Check that the chain guide is firmly seated.
  - » If the chain guide is loose:
    - Tighten the screws on the chain guide.

Guideline

Remaining screws, chassis	M6	10 Nm (7.4 lbf ft)
---------------------------	----	-----------------------

**Finishing work**

- Install the engine sprocket cover. 🛠️ (📖 p. 46)

- Remove the motorcycle from the lift stand. (🗨️ p. 30)

## 11.41 Adjusting the chain guide 🛠️

**i Info**  
The size of the chain wheel varies with the number of teeth. The chain guide can be adjusted on small sprockets.

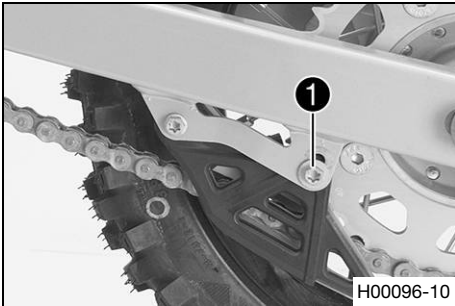

H00096-10

- Loosen screw ❶.
- Position the chain guide.
- Tighten the screw.

**Guideline**

Remaining screws, chassis	M6	10 Nm (7.4 lbf ft)
---------------------------	----	--------------------

## 11.42 Checking the frame 🛠️

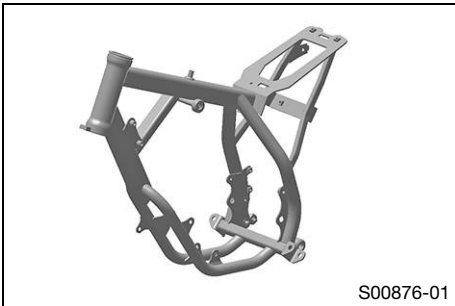

S00876-01

- Check the frame for cracks and deformation.
  - » If the frame exhibits cracks or deformation due to a mechanical impact:
    - Change the frame. 🛠️

**i Info**  
Always replace a frame that has been damaged due to a mechanical impact. Repair of the frame is not authorized by Husqvarna Motorcycles.

## 11.43 Checking the swingarm 🛠️

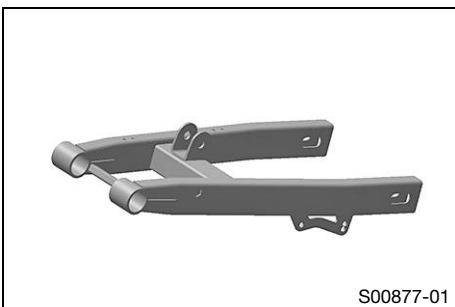

S00877-01

- Check the swingarm for damage, cracking, and deformation.
  - » If the swingarm shows signs of damage, cracking, or deformation:
    - Change the swingarm. 🛠️

**i Info**  
Always change a damaged swingarm. Repair of the swingarm is not authorized by Husqvarna Motorcycles.

## 11.44 Removing the fuel tank 🛠️

**⚠️ Danger**  
**Fire hazard** Fuel is highly flammable.

The fuel in the fuel tank expands when warm and can escape if overfilled.

- Do not refuel the vehicle in the vicinity of open flames or lit cigarettes.
- Switch off the engine for refueling.
- Make sure that no fuel is spilled; particularly not on hot parts of the vehicle.
- If any fuel is spilled, wipe it off immediately.
- Observe the specifications for refueling.



**Warning**

**Danger of poisoning** Fuel is poisonous and a health hazard.

- Avoid skin, eye and clothing contact with fuel.
- Immediately consult a doctor if you swallow fuel.
- Do not inhale fuel vapors.
- In case of skin contact, rinse the affected area with plenty of water.
- Rinse the eyes thoroughly with water, and consult a doctor in case of fuel contact with the eyes.
- Change your clothing in case of fuel spills on them.
- Keep fuels correctly in a suitable canister, and out of the reach of children.

**Preparatory work**

- Remove the seat. (📖 p. 42)
- Remove the left side cover. (📖 p. 39)
- Remove the right side cover. (📖 p. 38)
- Turn the knurled screw on the fuel tap all the way clockwise.

**Main work**

- Remove screw ❶.

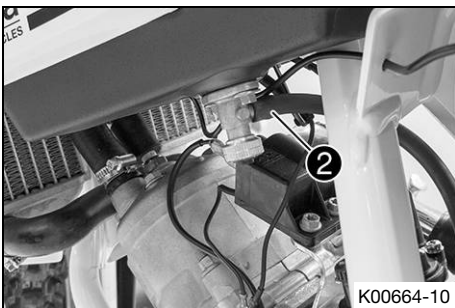

- Raise the fuel tank.
- Pull off fuel hose ❷.



**Info**

Remaining fuel may flow out of the fuel hose.

- Pull fuel tank breather out of the steering stem.
- Take off the fuel tank.

## 11.45 Installing the fuel tank ↗



**Danger**

**Fire hazard** Fuel is highly flammable.

The fuel in the fuel tank expands when warm and can escape if overfilled.

- Do not refuel the vehicle in the vicinity of open flames or lit cigarettes.
- Switch off the engine for refueling.
- Make sure that no fuel is spilled; particularly not on hot parts of the vehicle.
- If any fuel is spilled, wipe it off immediately.
- Observe the specifications for refueling.



**Warning**

**Danger of poisoning** Fuel is poisonous and a health hazard.

- Avoid skin, eye and clothing contact with fuel.
- Immediately consult a doctor if you swallow fuel.
- Do not inhale fuel vapors.
- In case of skin contact, rinse the affected area with plenty of water.
- Rinse the eyes thoroughly with water, and consult a doctor in case of fuel contact with the eyes.
- Change your clothing in case of fuel spills on them.
- Keep fuels correctly in a suitable canister, and out of the reach of children.

### Main work

- Check the throttle cable routing. (📖 p. 52)
- Mount fuel hose ①.



K00664-11

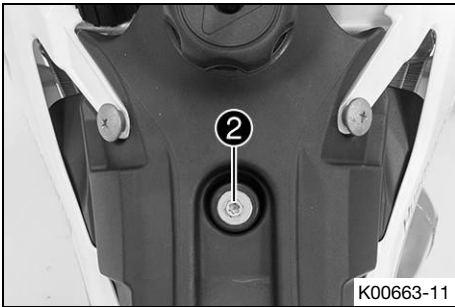

K00663-11

- Position the fuel tank.
- Make sure that no cables or throttle cables are trapped or damaged.
- Mount and tighten screw ②.

### Guideline

Remaining screws, chassis	M6	10 Nm (7.4 lbf ft)
---------------------------	----	--------------------

- Position the fuel tank breather in the steering stem.

### Finishing work

- Install the left side cover. (📖 p. 40)
- Install the right side cover. (📖 p. 38)
- Mount the seat. (📖 p. 43)

## 11.46 Checking the routing of the throttle cable

### Warning



**Danger of accidents** The throttle cable may slip out of the guide if routed incorrectly.

The throttle slide will then no longer be closed and the speed can no longer be controlled.

- Make sure that the throttle cable routing and the play in throttle cable complies with the specification.

### Preparatory work

- Remove the seat. (📖 p. 42)
- Remove the left side cover. (📖 p. 39)
- Remove the right side cover. (📖 p. 38)
- Turn the knurled screw on the fuel tap all the way clockwise.
- Remove the fuel tank. 🗑️ (📖 p. 50)

### Main work

- Check the throttle cable routing.

The throttle cable must be routed to the carburetor behind the handlebars and underneath the fuel tank bracket. The throttle cable must be fixed on the fuel tank bracket with a rubber band.

- » If the throttle cable is not routed as specified:
  - Correct the throttle cable routing.

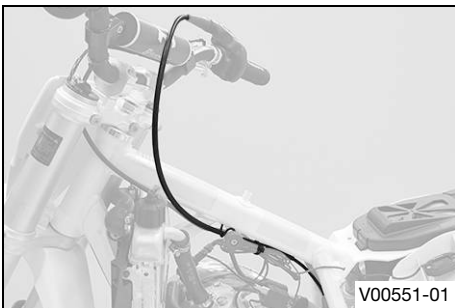

V00551-01

### Finishing work

- Install the fuel tank. 🗑️ (📖 p. 51)
- Install the left side cover. (📖 p. 40)
- Install the right side cover. (📖 p. 38)
- Mount the seat. (📖 p. 43)

## 11.47 Checking the rubber grip

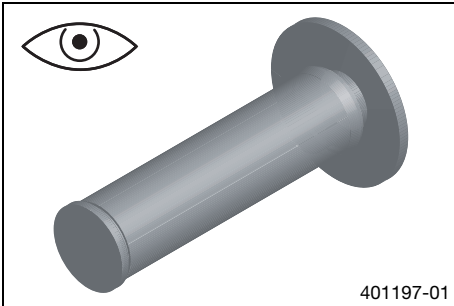

- Check the rubber grips on the handlebar for damage, wear, and looseness.
  - » If a rubber grip is damaged, worn, or loose:
    - Change and secure the rubber grip.

Grip adhesive (00062030051) (📖 p. 89)

## 11.48 Additionally securing the rubber grip



### Preparatory work

- Check the rubber grip. (📖 p. 53)

### Main work

- Secure the rubber grip at two locations with the retaining wire.

Securing wire (54812016000)

Wire twister forceps (U6907854)

- ✓ The twisted wire ends face away from the palms and are bent in toward the rubber grip.

## 12.1 Checking play of handbrake lever

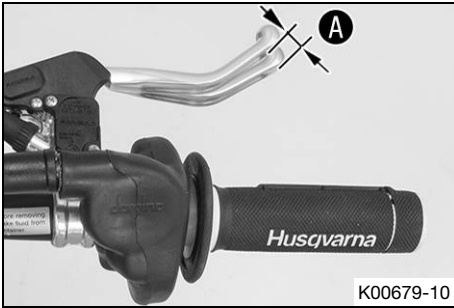

- Push the handbrake lever forwards and check the play **A**.

Play of hand brake lever	3... 5 mm (0.12... 0.2 in)
--------------------------	----------------------------

- » If the play does not meet specifications:
  - Adjust the play of the hand brake lever. (📖 p. 54)

## 12.2 Adjusting the play of the hand brake lever

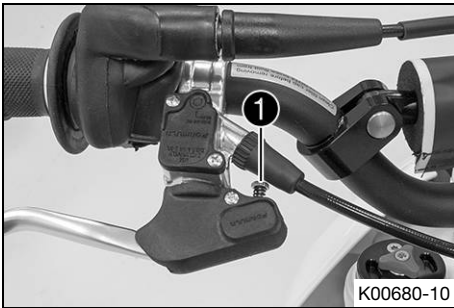

- Check the play of the handbrake lever. (📖 p. 54)
- Adjust the play of the hand brake lever using adjusting screw **1**.

Guideline

Play of hand brake lever	3... 5 mm (0.12... 0.2 in)
--------------------------	----------------------------

## 12.3 Adjusting the basic position of the hand brake lever

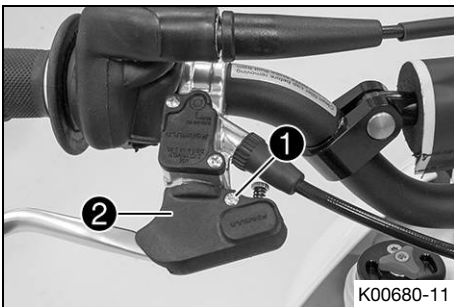

- Remove screw **1**. Take off cover **2**.

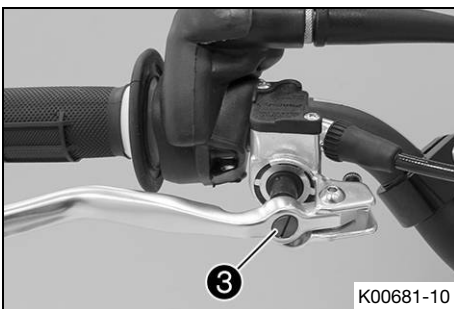

- Check the play of the handbrake lever. (📖 p. 54)
- Adjust the basic position of the hand brake lever with adjusting screw **3** to the rider's hand size.

**i Info**

Turn the adjusting screw clockwise to increase the distance between the hand brake lever and the handlebar.  
 Turn the adjusting screw counterclockwise to decrease the distance between the hand brake lever and the handlebar.  
 The range of adjustment is limited.

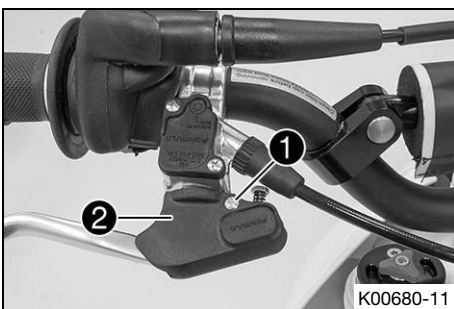

- Position cover **2**. Mount and tighten screw **1**.



## 12.4 Checking the brake discs

- Warning**  
**Danger of accidents** Worn-out brake discs reduce the braking effect.
- Make sure that worn-out brake discs are replaced immediately. (Your authorized Husqvarna Motorcycles workshop will be glad to help.)

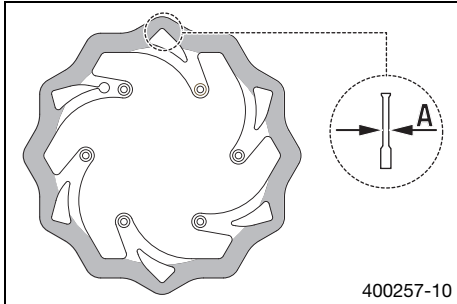

- Check the thickness of the front and rear brake discs at multiple points on each brake disc to ensure it is at least thickness **A**.

**Info**  
 Wear reduces the thickness of the brake disc around the area used by the brake linings.

Brake discs - wear limits	
Front	2.2 mm (0.087 in)
Rear	2.2 mm (0.087 in)

- » If the brake disc thickness is less than the specified value:
  - Change the front brake disc. 🛠️
  - Change the rear brake disc. 🛠️
- Check the front and rear brake discs for damage, cracking, and deformation.
  - » If the brake disc exhibits damage, cracking, or deformation:
    - Change the front brake disc. 🛠️
    - Change the rear brake disc. 🛠️

## 12.5 Checking the front brake fluid level

- Warning**  
**Danger of accidents** An insufficient brake fluid level will cause the brake system to fail.
- If the brake fluid level drops below the specified marking or the specified value, the brake system is leaking or the brake linings are worn down.

- Check the brake system and do not continue riding until the problem is eliminated. (Your authorized Husqvarna Motorcycles workshop will be glad to help.)

- Warning**  
**Skin irritation** Brake fluid causes skin irritation.

- Keep brake fluid out of the reach of children.
- Wear suitable protective clothing and safety glasses.
- Do not allow brake fluid to come into contact with the skin, the eyes or clothing.
- Consult a doctor immediately if brake fluid has been swallowed.
- Rinse the affected area with plenty of water in the event of contact with the skin.
- Rinse eyes thoroughly with water immediately and consult a doctor if brake fluid comes into contact with the eyes.
- If brake fluid spills on to your clothing, change the clothing.

- Warning**  
**Danger of accidents** Old brake fluid reduces the braking effect.

- Make sure that brake fluid for the front and rear brake is changed in accordance with the service schedule. (Your authorized Husqvarna Motorcycles workshop will be glad to help.)

- Warning**  
**Environmental hazard** Hazardous substances cause environmental damage.

- Dispose of oils, grease, filters, fuel, cleaning agents, brake fluid, etc., correctly and in compliance with the applicable regulations.

**i Info**

Never use DOT 5 brake fluid. It is silicone-based and purple in color. Oil seals and brake lines are not designed for DOT 5 brake fluid.  
 Avoid contact between brake fluid and painted parts. Brake fluid attacks paint.  
 Only use clean brake fluid from a sealed container.

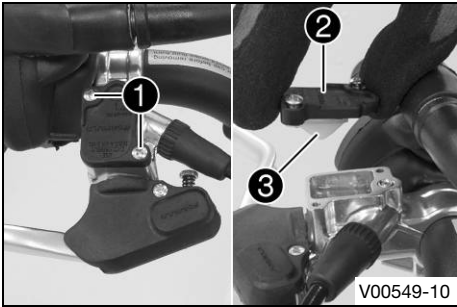

- Move the brake fluid reservoir mounted on the handlebar to a horizontal position.
- Remove screws ①.
- Remove cover ② with membrane ③.
- Check the brake fluid level.

Brake fluid level under top level of container	5 mm (0.2 in)
--	---------------

» If the brake fluid level does not meet specifications:

- Add front brake fluid. 📖 (p. 56)
- Position the cover with the membrane. Mount and tighten the screws.

**i Info**

Clean up overflowed or spilled brake fluid immediately with water.

## 12.6 Adding front brake fluid 📖

**⚠ Warning**

**Danger of accidents** An insufficient brake fluid level will cause the brake system to fail.

If the brake fluid level drops below the specified marking or the specified value, the brake system is leaking or the brake linings are worn down.

- Check the brake system and do not continue riding until the problem is eliminated. (Your authorized Husqvarna Motorcycles workshop will be glad to help.)

**⚠ Warning**

**Skin irritation** Brake fluid causes skin irritation.

- Keep brake fluid out of the reach of children.
- Wear suitable protective clothing and safety glasses.
- Do not allow brake fluid to come into contact with the skin, the eyes or clothing.
- Consult a doctor immediately if brake fluid has been swallowed.
- Rinse the affected area with plenty of water in the event of contact with the skin.
- Rinse eyes thoroughly with water immediately and consult a doctor if brake fluid comes into contact with the eyes.
- If brake fluid spills on to your clothing, change the clothing.

**⚠ Warning**

**Danger of accidents** Old brake fluid reduces the braking effect.

- Make sure that brake fluid for the front and rear brake is changed in accordance with the service schedule. (Your authorized Husqvarna Motorcycles workshop will be glad to help.)

**☀ Warning**

**Environmental hazard** Hazardous substances cause environmental damage.

- Dispose of oils, grease, filters, fuel, cleaning agents, brake fluid, etc., correctly and in compliance with the applicable regulations.

**i Info**

Never use DOT 5 brake fluid. It is silicone-based and purple in color. Oil seals and brake lines are not designed for DOT 5 brake fluid.  
 Avoid contact between brake fluid and painted parts. Brake fluid attacks paint.  
 Only use clean brake fluid from a sealed container.

**Preparatory work**

- Check the front brake linings. 📖 (p. 57)

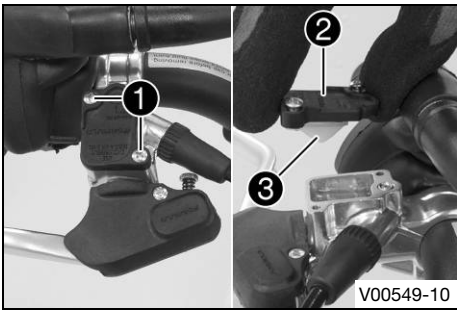

**Main work**

- Move the brake fluid reservoir mounted on the handlebar to a horizontal position.
- Remove screws ①.
- Remove cover ② with membrane ③.
- Correct the brake fluid level.

Guideline

Brake fluid level under top level of container	5 mm (0.2 in)
--	---------------

Brake fluid DOT 4 (📖 p. 87)
-----------------------------

- Position the cover with the membrane. Mount and tighten the screws.

**i Info**

Clean up overflowed or spilled brake fluid immediately with water.

## 12.7 Checking the front brake linings

**Warning**

**Danger of accidents** Worn-out brake linings reduce the braking effect.

- Ensure that worn-out brake linings are replaced immediately. (Your authorized Husqvarna Motorcycles workshop will be glad to help.)

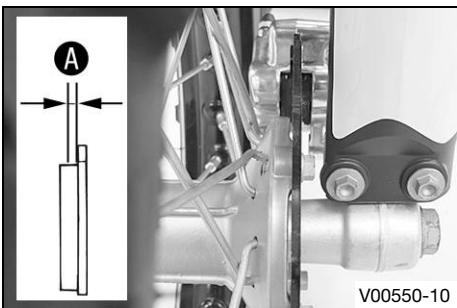

- Check the brake linings for minimum thickness ①.

Minimum thickness ①	≥ 1 mm (≥ 0.04 in)
---------------------	--------------------

- » If the minimum thickness is less than specified:
  - Change the front brake linings. 🛠️ (📖 p. 57)
- Check the brake linings for damage and cracking.
  - » If damage or wear is encountered:
    - Change the front brake linings. 🛠️ (📖 p. 57)

## 12.8 Changing the front brake linings 🛠️

**Warning**

**Danger of accidents** Incorrect maintenance will cause the brake system to fail.

- Ensure that service work and repairs are performed professionally. (Your authorized Husqvarna Motorcycles workshop will be glad to help.)

**Warning**

**Skin irritation** Brake fluid causes skin irritation.

- Keep brake fluid out of the reach of children.
- Wear suitable protective clothing and safety glasses.
- Do not allow brake fluid to come into contact with the skin, the eyes or clothing.
- Consult a doctor immediately if brake fluid has been swallowed.
- Rinse the affected area with plenty of water in the event of contact with the skin.
- Rinse eyes thoroughly with water immediately and consult a doctor if brake fluid comes into contact with the eyes.
- If brake fluid spills on to your clothing, change the clothing.

**Warning**

**Danger of accidents** Old brake fluid reduces the braking effect.

- Make sure that brake fluid for the front and rear brake is changed in accordance with the service schedule. (Your authorized Husqvarna Motorcycles workshop will be glad to help.)

**Warning**

**Danger of accidents** Brake linings which have not been approved alter the braking efficiency.

Not all brake linings are tested and approved for Husqvarna motorcycles. The structure and friction coefficient of the brake linings, and thus their brake power, may vary greatly from that of original brake linings.

If brake linings are used that differ from the original equipment, compliance with the original homologation is not guaranteed. In this case, the vehicle no longer corresponds to its condition at delivery and the warranty shall be void.

- Only use brake linings approved and recommended by Husqvarna motorcycles.

**Warning**

**Environmental hazard** Hazardous substances cause environmental damage.

- Dispose of oils, grease, filters, fuel, cleaning agents, brake fluid, etc., correctly and in compliance with the applicable regulations.

**Info**

Never use DOT 5 brake fluid. It is silicone-based and purple in color. Oil seals and brake lines are not designed for DOT 5 brake fluid.

Avoid contact between brake fluid and painted parts. Brake fluid attacks paint.

Only use clean brake fluid from a sealed container.

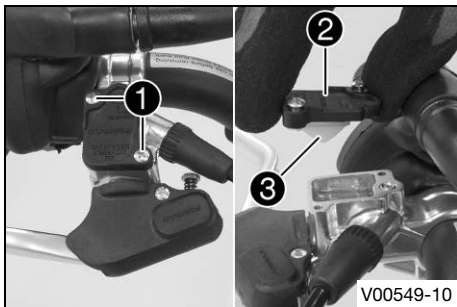

V00549-10

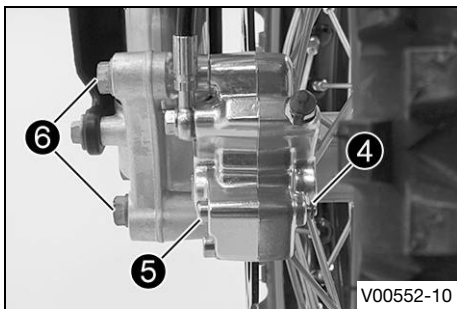

V00552-10

**Preparatory work**

- Raise the motorcycle with a lift stand. (📖 p. 30)

**Main work**

- Move the brake fluid reservoir mounted on the handlebar to a horizontal position.
- Remove screws **1**.
- Remove cover **2** with membrane **3**.

- Remove lock washer **4**.
- Loosen screw **5**.
- Remove screws **6**.
- Carefully pull the brake caliper backward from the brake disc.
- Remove screw **5**.

**Warning**

**Danger of accidents** Oil or grease on the brake discs reduces the braking effect.

- Always keep the brake discs free of oil and grease.
- Clean the brake discs with brake cleaner when necessary.

- Check the brake discs. (📖 p. 55)
- Remove the brake linings.
- Clean the brake caliper and brake caliper support.
- Press the brake piston back into the basic position and ensure that brake fluid does not flow out of the brake fluid reservoir, sucking it away if necessary.

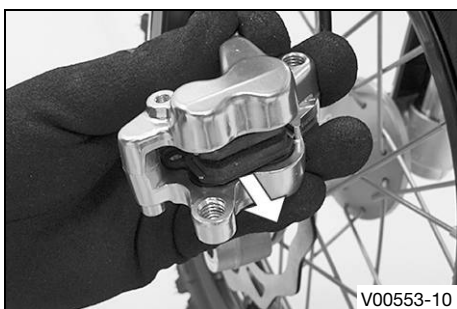

V00553-10

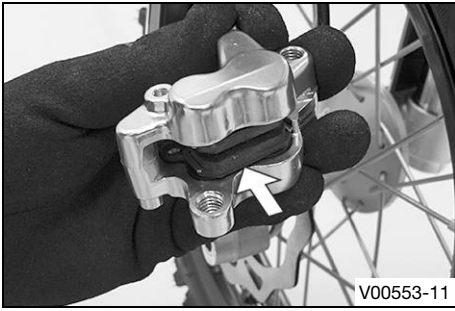

**Warning**

**Danger of accidents** Brake linings which have not been approved alter the braking efficiency.

Not all brake linings are tested and approved for Husqvarna motorcycles. The structure and friction coefficient of the brake linings, and thus their brake power, may vary greatly from that of original brake linings. If brake linings are used that differ from the original equipment, compliance with the original homologation is not guaranteed. In this case, the vehicle no longer corresponds to its condition at delivery and the warranty shall be void.

- Only use brake linings approved and recommended by Husqvarna motorcycles.

- Position the new brake linings.



**Info**

Always change the brake linings in pairs. Ensure that the brake linings are correctly positioned in the holding spring.

- Position the brake caliper.
- Mount and tighten screw ⑤.

Guideline

Screw, brake linings	M5	8 Nm (5.9 lbf ft)
----------------------	----	-------------------

- Mount lock washer ④.
- Mount and tighten screws ⑥.

Guideline

Screw, front brake caliper	M8	20 Nm (14.8 lbf ft)	Loctite® 243™
----------------------------	----	---------------------	---------------

- Operate the hand brake lever repeatedly until the brake linings lie on the brake disc and there is a pressure point.
- Correct the brake fluid level.

Guideline

Brake fluid level under top level of container	5 mm (0.2 in)
--	---------------

Brake fluid DOT 4 (📖 p. 87)
-----------------------------

- Position the cover with the membrane. Mount and tighten the screws.



**Info**

Clean up overflowed or spilled brake fluid immediately with water.

**Finishing work**

- Remove the motorcycle from the lift stand. (📖 p. 30)

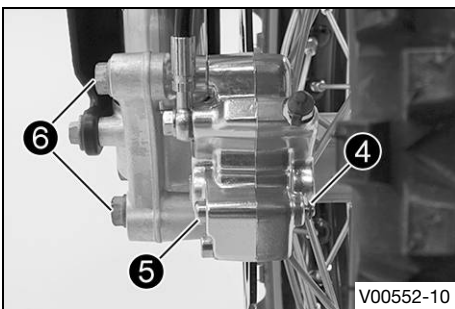

## 12.9 Checking the free travel of the foot brake lever



**Warning**

**Danger of accidents** The brake system fails in the event of overheating.

If there is no free travel on the foot brake lever, pressure builds up in the brake system on the rear brake.

- Set the free travel on the foot brake lever in accordance with the specification.

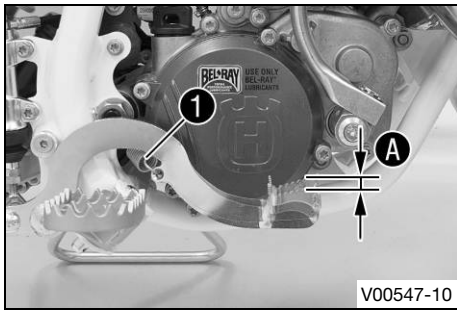

- Disconnect spring ①.
- Move the foot brake lever back and forth between the end stop and the foot brake cylinder piston bracket and check free travel A.

Guideline

Free travel of foot brake lever	3... 5 mm (0.12... 0.2 in)
---------------------------------	----------------------------

- » If the free travel does not meet specifications:
  - Adjust the free travel of the foot brake lever. 🛠️ (p. 60)
- Attach spring ①.

## 12.10 Adjusting the free travel of the foot brake lever 🛠️

**Warning**

**Danger of accidents** The brake system fails in the event of overheating.  
If there is no free travel on the foot brake lever, pressure builds up in the brake system on the rear brake.

- Set the free travel on the foot brake lever in accordance with the specification.

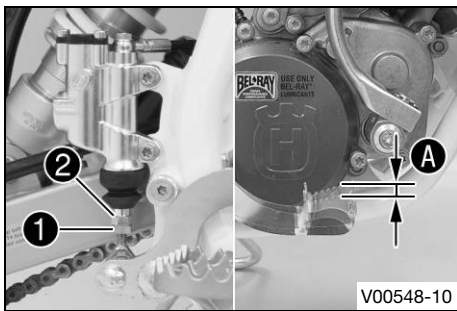

- Detach foot brake lever spring.
- Loosen nut ①.
- Turn push rod ② accordingly until you have free travel A.

Guideline

Free travel of foot brake lever	3... 5 mm (0.12... 0.2 in)
---------------------------------	----------------------------

- Hold push rod ② and tighten nut ①.
- Attach foot brake lever spring.
- Check whether the basic position of the foot brake lever is suitable for the rider.
  - » When the basic position of the foot brake lever needs to be adjusted:
    - Adjust the basic position of the foot brake lever. 🛠️ (p. 60)

## 12.11 Adjusting the basic position of the foot brake lever 🛠️

**Warning**

**Danger of accidents** The brake system fails in the event of overheating.  
If there is no free travel on the foot brake lever, pressure builds up in the brake system on the rear brake.

- Set the free travel on the foot brake lever in accordance with the specification.

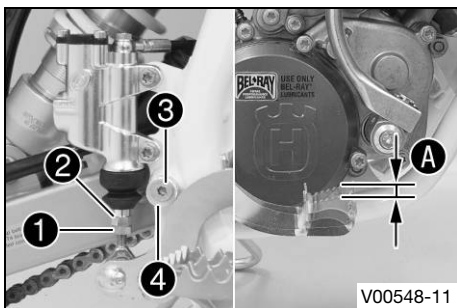

- Detach the spring.
- Loosen nut ①.
- Turn back push rod ② until free travel is at a maximum.
- For an individual adjustment of the basic position of the foot brake lever, loosen the screw ③ and turn the eccentric brake lever stop ④ accordingly.
- Tighten screw ③.

Guideline

Remaining screws, chassis	M6	10 Nm (7.4 lbf ft)
---------------------------	----	--------------------

- Turn push rod ② accordingly until you have free travel A.

Guideline

Free travel of foot brake lever	3... 5 mm (0.12... 0.2 in)
---------------------------------	----------------------------

- Hold push rod ② and tighten nut ①.
- Attach spring.
- Check whether the basic position of the foot brake lever is suitable for the rider.

## 12.12 Checking the rear brake fluid level

- Warning**  
**Danger of accidents** An insufficient brake fluid level will cause the brake system to fail.  
If the brake fluid level drops below the specified marking or the specified value, the brake system is leaking or the brake linings are worn down.
- Check the brake system and ensure that nobody drives the vehicle before the problem is eliminated. (Your authorized Husqvarna Motorcycles workshop will be glad to help.)

- Warning**  
**Danger of accidents** Old brake fluid reduces the braking effect.
- Make sure that brake fluid for the front and rear brake is changed in accordance with the service schedule. (Your authorized Husqvarna Motorcycles workshop will be glad to help.)

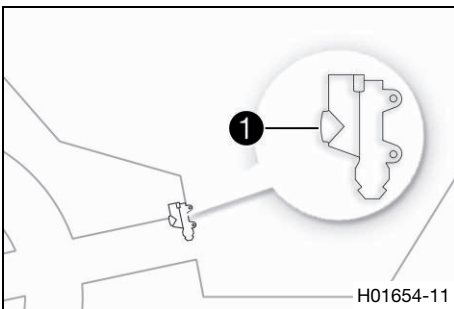

- Stand the vehicle upright.
- Check the brake fluid level in level viewer 1.
  - » If an air bubble is visible in viewer 1:
    - Add rear brake fluid. 🛠️ (p. 61)

## 12.13 Adding rear brake fluid 🛠️

- Warning**  
**Danger of accidents** An insufficient brake fluid level will cause the brake system to fail.  
If the brake fluid level drops below the specified marking or the specified value, the brake system is leaking or the brake linings are worn down.
- Check the brake system and ensure that nobody drives the vehicle before the problem is eliminated. (Your authorized Husqvarna Motorcycles workshop will be glad to help.)

- Warning**  
**Skin irritation** Brake fluid causes skin irritation.
- Keep brake fluid out of the reach of children.
  - Wear suitable protective clothing and safety glasses.
  - Do not allow brake fluid to come into contact with the skin, the eyes or clothing.
  - Consult a doctor immediately if brake fluid has been swallowed.
  - Rinse the affected area with plenty of water in the event of contact with the skin.
  - Rinse eyes thoroughly with water immediately and consult a doctor if brake fluid comes into contact with the eyes.
  - If brake fluid spills on to your clothing, change the clothing.

- Warning**  
**Danger of accidents** Old brake fluid reduces the braking effect.
- Make sure that brake fluid for the front and rear brake is changed in accordance with the service schedule. (Your authorized Husqvarna Motorcycles workshop will be glad to help.)

- Warning**  
**Environmental hazard** Hazardous substances cause environmental damage.
- Dispose of oils, grease, filters, fuel, cleaning agents, brake fluid, etc., correctly and in compliance with the applicable regulations.

- Info**  
Never use DOT 5 brake fluid. It is silicone-based and purple in color. Oil seals and brake lines are not designed for DOT 5 brake fluid.  
Avoid contact between brake fluid and painted parts. Brake fluid attacks paint.  
Only use clean brake fluid from a sealed container.

### Preparatory work

- Raise the motorcycle with a lift stand. (📖 p. 30)
- Check the rear brake linings. (📖 p. 62)

### Main work

- Remove screws ❶.
- Take off cover ❷ with washer ❸ and membrane ❹.

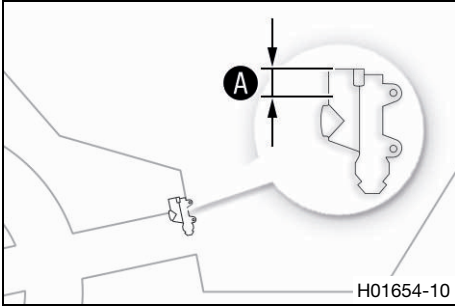
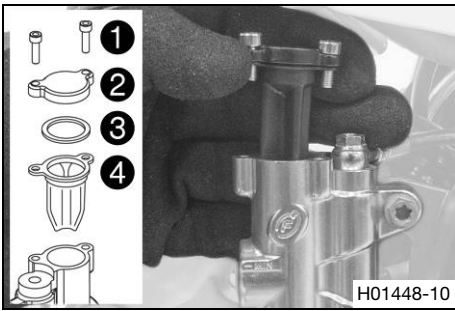

- Add brake fluid up to level ❶.

#### Guideline

Level ❶ (brake fluid level below reservoir rim)	10 mm (0.39 in)
---	-----------------

Brake fluid DOT 4 (📖 p. 87)
-----------------------------

- Position the cover with the washer and membrane.
- Mount and tighten the screws.

#### **i** Info

Clean up overflowed or spilled brake fluid immediately with water.

### Finishing work

- Remove the motorcycle from the lift stand. (📖 p. 30)

## 12.14 Checking the rear brake linings

### **!** Warning

**Danger of accidents** Worn-out brake linings reduce the braking effect.

- Ensure that worn-out brake linings are replaced immediately. (Your authorized Husqvarna Motorcycles workshop will be glad to help.)

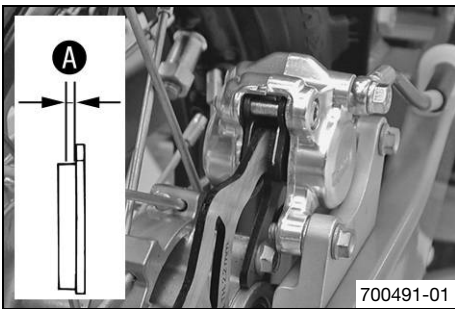

- Check the brake linings for minimum thickness ❶.

Minimum thickness ❶	≥ 1 mm (≥ 0.04 in)
---------------------	--------------------

- » If the minimum thickness is less than specified:
  - Change the rear brake linings. 🛠️ (📖 p. 62)
- Check the brake linings for damage and cracking.
  - » If damage or wear is encountered:
    - Change the rear brake linings. 🛠️ (📖 p. 62)

## 12.15 Changing the rear brake linings 🛠️

### **!** Warning

**Danger of accidents** Incorrect maintenance will cause the brake system to fail.

- Ensure that service work and repairs are performed professionally. (Your authorized Husqvarna Motorcycles workshop will be glad to help.)





**Warning**

**Skin irritation** Brake fluid causes skin irritation.

- Keep brake fluid out of the reach of children.
- Wear suitable protective clothing and safety glasses.
- Do not allow brake fluid to come into contact with the skin, the eyes or clothing.
- Consult a doctor immediately if brake fluid has been swallowed.
- Rinse the affected area with plenty of water in the event of contact with the skin.
- Rinse eyes thoroughly with water immediately and consult a doctor if brake fluid comes into contact with the eyes.
- If brake fluid spills on to your clothing, change the clothing.



**Warning**

**Danger of accidents** Old brake fluid reduces the braking effect.

- Make sure that brake fluid for the front and rear brake is changed in accordance with the service schedule. (Your authorized Husqvarna Motorcycles workshop will be glad to help.)



**Warning**

**Danger of accidents** Oil or grease on the brake discs reduces the braking effect.

- Always keep the brake discs free of oil and grease.
- Clean the brake discs with brake cleaner when necessary.



**Warning**

**Danger of accidents** Brake linings which have not been approved alter the braking efficiency.

Not all brake linings are tested and approved for Husqvarna motorcycles. The structure and friction coefficient of the brake linings, and thus their brake power, may vary greatly from that of original brake linings.

If brake linings are used that differ from the original equipment, compliance with the original homologation is not guaranteed. In this case, the vehicle no longer corresponds to its condition at delivery and the warranty shall be void.

- Only use brake linings approved and recommended by Husqvarna motorcycles.



**Warning**

**Environmental hazard** Hazardous substances cause environmental damage.

- Dispose of oils, grease, filters, fuel, cleaning agents, brake fluid, etc., correctly and in compliance with the applicable regulations.



**Info**

Never use DOT 5 brake fluid. It is silicone-based and purple in color. Oil seals and brake lines are not designed for DOT 5 brake fluid.

Avoid contact between brake fluid and painted parts. Brake fluid attacks paint.

Only use clean brake fluid from a sealed container.

**Preparatory work**

- Raise the motorcycle with a lift stand. (📖 p. 30)

**Main work**

- Remove lock washer ①.
- Remove screw ②.
- Remove screws ③.

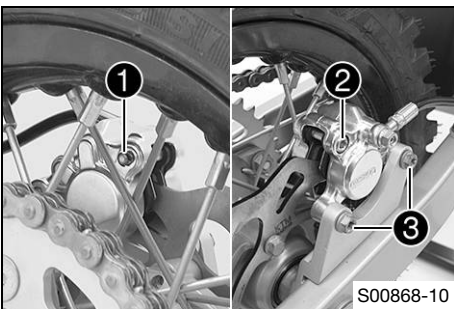

- Take off the brake caliper and pull the brake line out of holder ④.



**Info**

Do not kink or damage the brake line.

- Remove the brake linings.
- Clean the brake caliper and brake caliper support.

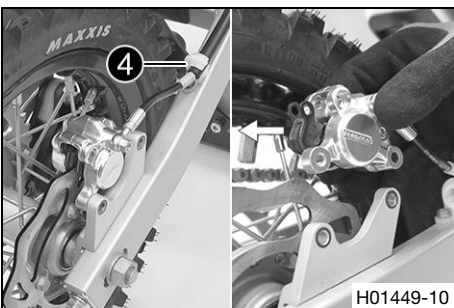

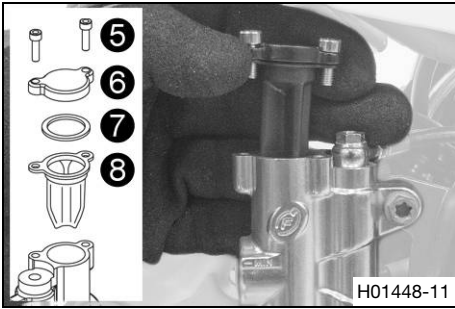

- Allow the brake caliper and brake line to hang loosely to the side.
- Remove screws ⑤.
- Take off cover ⑥ with washer ⑦ and membrane ⑧.
- Press the brake piston back into the basic position and ensure that brake fluid does not flow out of the brake fluid reservoir, sucking it away if necessary.

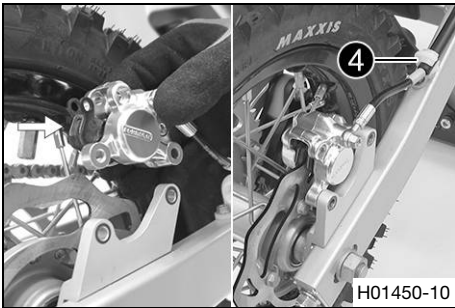

- Position the new brake linings.

**i Info**

Always change the brake linings in pairs.  
Ensure that the brake linings are correctly positioned in the holding spring.

- Position the brake caliper on the brake disc.  
✓ The brake linings are correctly positioned.
- Attach the brake line to holder ④.

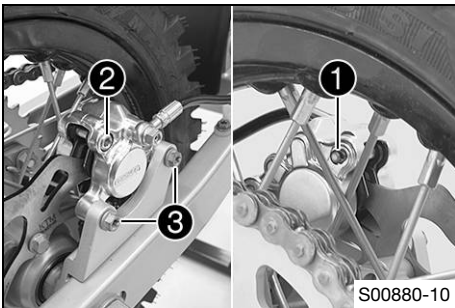

- Mount and tighten screws ③.

Guideline

Rear brake caliper screw	M6	10 Nm (7.4 lbf ft)	Loctite® 243™
--------------------------	----	-----------------------	---------------

- Mount screw ②.

Guideline

Screw, brake linings	M5	8 Nm (5.9 lbf ft)
----------------------	----	-------------------

- Mount lock washer ①.
- Check the brake discs. (📖 p. 55)
- Operate the foot brake lever repeatedly until the brake linings are in contact with the brake disc and there is a pressure point.

- Add brake fluid up to level ①.

Guideline

Level ① (brake fluid level below reservoir rim)	10 mm (0.39 in)
---	-----------------

Brake fluid DOT 4 (📖 p. 87)
-----------------------------

- Position the cover with the washer and membrane.
- Mount and tighten the screws.

**i Info**

Clean up overflowed or spilled brake fluid immediately with water.

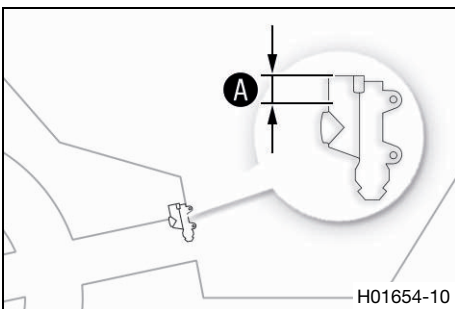

**Finishing work**

- Remove the motorcycle from the lift stand. (📖 p. 30)

## 13.1 Removing the front wheel

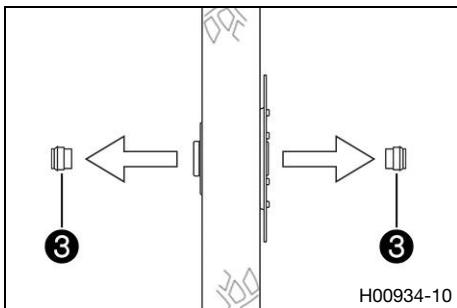
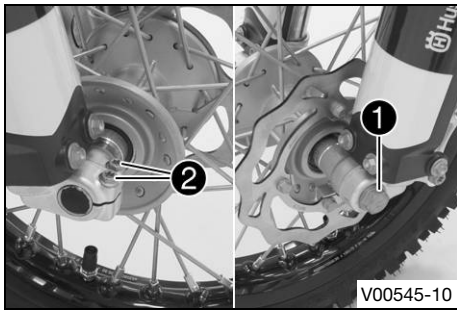

### Preparatory work

- Raise the motorcycle with a lift stand. (p. 30)

### Main work

- Remove screw ①.
- Loosen screws ②.



### Warning

**Danger of accidents** Damaged brake discs reduce the braking effect.

- Always lay the wheel down in such a way that the brake disc is not damaged.

- Holding the front wheel, withdraw the wheel spindle. Take the front wheel out of the fork.



### Info

Do not pull the hand brake lever when the front wheel is removed.

- Remove spacers ③.

## 13.2 Installing the front wheel



### Warning

**Danger of accidents** Oil or grease on the brake discs reduces the braking effect.

- Always keep the brake discs free of oil and grease.
- Clean the brake discs with brake cleaner when necessary.

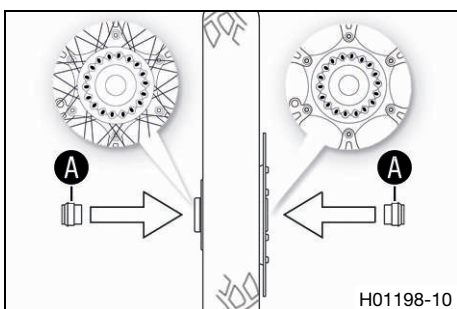

- Check the wheel bearing for damage and wear.
  - » If the wheel bearing is damaged or worn:
    - Change the front wheel bearing.
- Clean and grease the contact surfaces A of the spacers.

Long-life grease (p. 89)

- Insert the spacers.

- Clean and grease wheel spindle.

Long-life grease (p. 89)

- Position the front wheel.
  - ✓ The brake linings are correctly positioned.
- Insert wheel spindle.

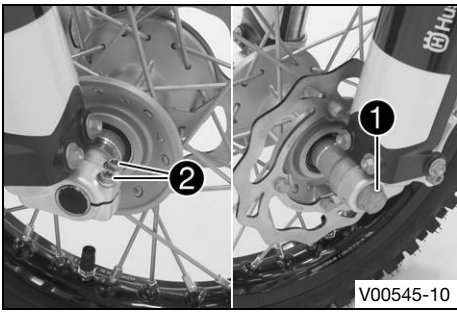

- Mount and tighten screw ①.

Guideline

Screw, front wheel spindle	M10	40 Nm (29.5 lbf ft)	Loctite® 243™
----------------------------	-----	---------------------	---------------

- Operate the hand brake lever several times until the brake linings are seated correctly against the brake disc.
- Remove the motorcycle from the lift stand. (📖 p. 30)
- Operate the front brake and compress the fork a few times firmly.
  - ✓ The fork legs straighten.
- Tighten screws ②.

Guideline

Screw, fork stub	M6	10 Nm (7.4 lbf ft)	
------------------	----	--------------------	--

## 13.3 Removing the rear wheel ↩

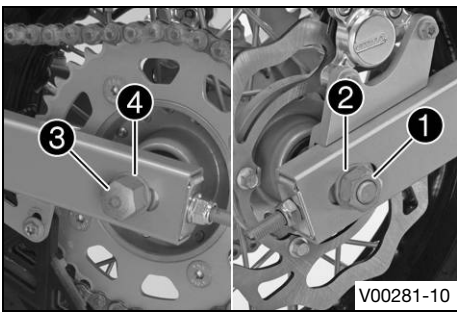

### Preparatory work

- Raise the motorcycle with a lift stand. (📖 p. 30)

### Main work

- Remove nut ① with washer ②.

**i Info**

Cover the components to protect them against damage.

- Pull out wheel spindle ③ with washer ④.
- Remove the chain from the rear sprocket.

**! Warning**

**Danger of accidents** Damaged brake discs reduce the braking effect.

- Always lay the wheel down in such a way that the brake disc is not damaged.

- Take the rear wheel out of the swingarm.

**i Info**

Do not operate the foot brake lever when the rear wheel is removed.

- Remove spacers ⑤.

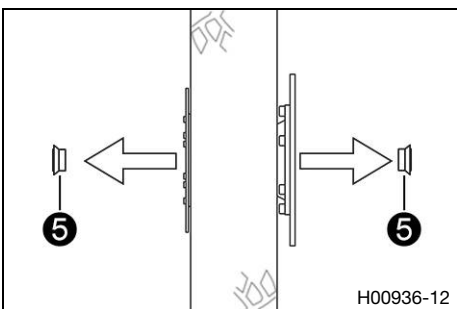

## 13.4 Installing the rear wheel ↩

**! Warning**

**Danger of accidents** Oil or grease on the brake discs reduces the braking effect.

- Always keep the brake discs free of oil and grease.
- Clean the brake discs with brake cleaner when necessary.

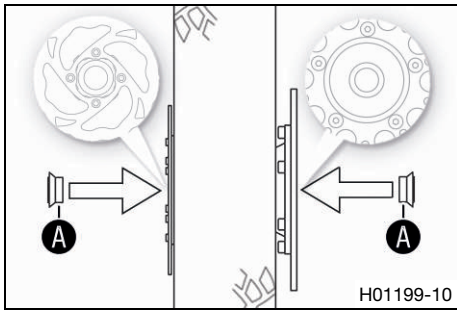

**Main work**

- Check the wheel bearing for damage and wear.
  - » If the wheel bearing is damaged or worn:
    - Change the rear wheel bearing. 🛠️
- Clean and grease the contact surfaces **A** of the spacers.

Long-life grease (📖 p. 89)

- Insert the spacers.

**i Info**

Insert the wide spacer on the left in the direction of travel.

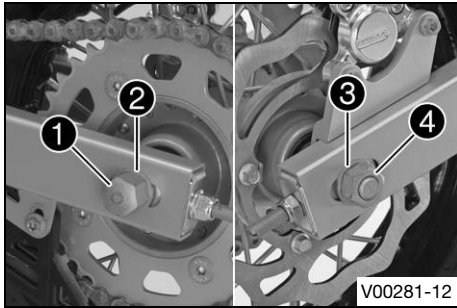

- Clean and grease wheel spindle **1**.

Long-life grease (📖 p. 89)

- Position rear wheel and mount the chain.
  - ✓ The brake linings are correctly positioned.
- Insert wheel spindle **1** with washer **2**.
- Position washer **3**. Mount nut **4**, but do not tighten it yet.
- Make sure that the chain adjuster support plates are in contact with the adjusting nuts.
- Check the chain tension. (📖 p. 47)
- Tighten nut **4**.

**Guideline**

Nut, rear wheel spindle	M12x1	40 Nm (29.5 lbf ft)
-------------------------	-------	---------------------

- Operate the foot brake lever repeatedly until the brake linings are in contact with the brake disc and there is a pressure point.

**Finishing work**

- Remove the motorcycle from the lift stand. (📖 p. 30)

**13.5 Checking the tire condition**

**i Info**

Only mount tires approved and/or recommended by Husqvarna Motorcycles. Other tires could have a negative effect on handling characteristics. The type, condition, and air pressure of the tires all have a major impact on the handling of the motorcycle. The tires mounted on the front and rear wheels must have a similar profile. Worn tires have a negative effect on handling characteristics, especially on wet surfaces.

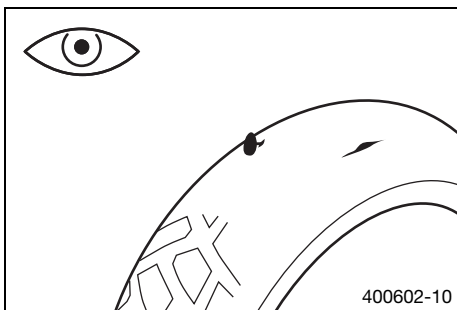

- Check the front and rear tires for cuts, run-in objects, and other damage.
  - » If the tires have cuts, run-in objects, or other damage:
    - Change the tires.
- Check the tread depth.

**i Info**

Adhere to the legally required minimum tread depth.

Minimum tread depth	≥ 2 mm (≥ 0.08 in)
---------------------	--------------------

- » If the tread depth is less than the minimum tread depth:
  - Change the tires.
- Check the tire age.

**i Info**

The tire date of manufacture is usually contained in the tire label and is indicated by the last four digits of the **DOT** number. The first two digits indicate the week of manufacture and the last two digits the year of manufacture. Husqvarna Motorcycles recommends that the tires be changed after 5 years at the latest, regardless of the actual state of wear.

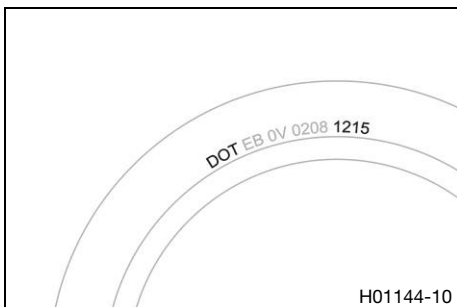

- » If the tires are more than 5 years old:
  - Change the tires.

## 13.6 Checking tire air pressure

### **i** Info

Low tire air pressure leads to abnormal wear and overheating of the tire. Correct tire air pressure ensures optimal riding comfort and maximum tire service life.

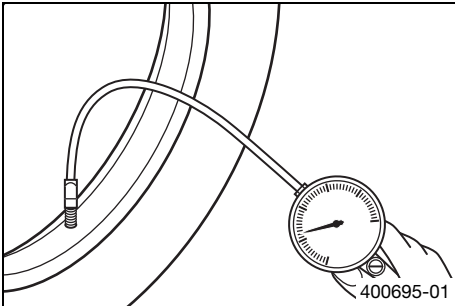

- Remove the protection cap.
- Check the tire air pressure when the tires are cold.

Tire air pressure off road	
Front	1.0 bar (15 psi)
Rear	1.0 bar (15 psi)

- » If the tire pressure does not meet specifications:
  - Correct the tire pressure.
- Mount the protection cap.

## 13.7 Checking spoke tension

### **!** Warning

**Danger of accidents** Incorrectly tensioned spokes impair the handling characteristic and result in secondary damage. The spokes break due to being overloaded if they are too tightly tensioned. If the tension in the spokes is too low, then lateral and radial run-out will form in the wheel. Other spokes will become looser as a result.

- Check spoke tension regularly, and in particular on a new vehicle. (Your authorized Husqvarna Motorcycles workshop will be glad to help.)

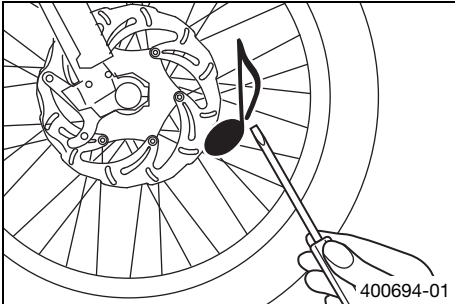

- Strike each spoke briefly using a screwdriver blade.

### **i** Info

The frequency of the sound depends on the spoke length and spoke diameter. If you hear different tone frequencies from different spokes of equal length and diameter, this is an indication of different spoke tensions.

You should hear a high note.

- » If the spoke tension differs:
  - Correct the spoke tension. 🛠️
- Check the spoke torque.

#### Guideline

Spoke nipple	M3.5	3 Nm (2.2 lbf ft)
--------------	------	-------------------

Torque wrench with various accessories in set (58429094000)

## 14.1 Cooling system

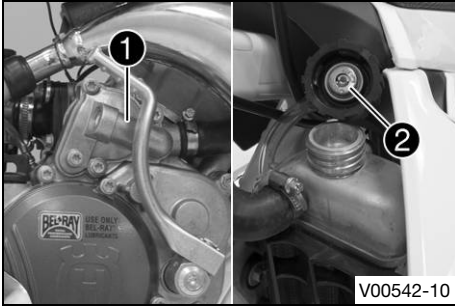

The water pump ① in the engine forces the coolant to flow. The pressure resulting from the warming of the cooling system is regulated by a valve in the radiator cap ②. This ensures that operating the vehicle at the specified coolant temperature will not result in a risk of malfunctions.

120 °C (248 °F)
-----------------

Cooling is effected by the air stream. The lower the speed, the less the cooling effect. Dirty cooling fins also reduce the cooling effect.

## 14.2 Checking the antifreeze and coolant level

- Warning**  
**Danger of scalding** During motorcycle operation, the coolant gets very hot and is under pressure.
- Do not open the radiator, the radiator hoses or other cooling system components if the engine or the cooling system are at operating temperature.
  - Allow the cooling system and the engine to cool down before you open the radiator, the radiator hoses or other components of the cooling system.
  - In the event of scalding, rinse the area affected immediately with lukewarm water.

- Warning**  
**Danger of poisoning** Coolant is toxic and a health hazard.
- Keep coolant out of the reach of children.
  - Do not allow coolant to come into contact with the skin, the eyes and clothing.
  - Consult a doctor immediately if coolant is swallowed.
  - Rinse the affected area immediately with plenty of water in the event of contact with the skin.
  - Rinse eyes thoroughly with water and consult a doctor immediately if coolant gets into the eyes.
  - Change clothing if coolant spills onto your clothing.

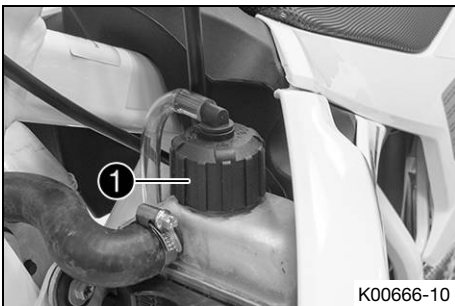

- Stand the motorcycle upright on a horizontal surface.
- Take off radiator cap ①.
- Check the antifreeze in the coolant.

-25... -45 °C (-13... -49 °F)
-------------------------------

- » If the antifreeze in the coolant does not match the specified value:
  - Correct the antifreeze in the coolant.

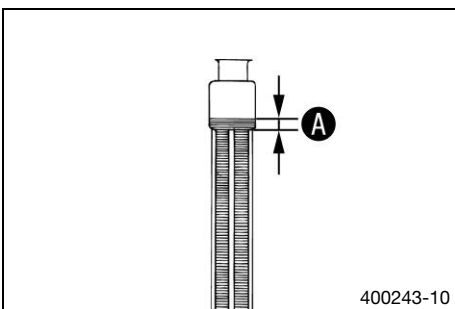

- Check the coolant level in the radiator.

Coolant level <b>A</b> above the radiator fins	10 mm (0.39 in)
--	-----------------

- » If the coolant level does not match the specified value:
  - Correct the coolant level.

Coolant (📖 p. 87)
-------------------

- Mount the radiator cap.

## 14.3 Checking the coolant level



### Warning

**Danger of scalding** During motorcycle operation, the coolant gets very hot and is under pressure.

- Do not open the radiator, the radiator hoses or other cooling system components if the engine or the cooling system are at operating temperature.
- Allow the cooling system and the engine to cool down before you open the radiator, the radiator hoses or other components of the cooling system.
- In the event of scalding, rinse the area affected immediately with lukewarm water.



### Warning

**Danger of poisoning** Coolant is toxic and a health hazard.

- Keep coolant out of the reach of children.
- Do not allow coolant to come into contact with the skin, the eyes and clothing.
- Consult a doctor immediately if coolant is swallowed.
- Rinse the affected area immediately with plenty of water in the event of contact with the skin.
- Rinse eyes thoroughly with water and consult a doctor immediately if coolant gets into the eyes.
- Change clothing if coolant spills onto your clothing.

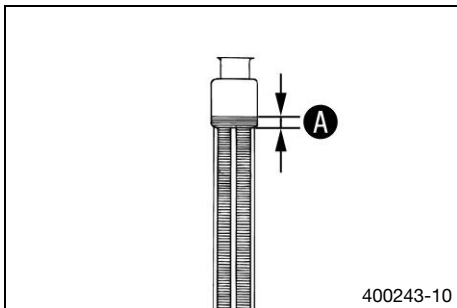

- Stand the motorcycle upright on a horizontal surface.
- Remove the radiator cap.
- Check the coolant level in the radiator.

Coolant level <b>A</b> above the radiator fins	10 mm (0.39 in)
--	-----------------

- » If the coolant level does not match the specified value:
  - Correct the coolant level.

Coolant (📖 p. 87)
-------------------

- Mount the radiator cap.

## 14.4 Draining the coolant 🐘



### Warning

**Danger of scalding** During motorcycle operation, the coolant gets very hot and is under pressure.

- Do not open the radiator, the radiator hoses or other cooling system components if the engine or the cooling system are at operating temperature.
- Allow the cooling system and the engine to cool down before you open the radiator, the radiator hoses or other components of the cooling system.
- In the event of scalding, rinse the area affected immediately with lukewarm water.



### Warning

**Danger of poisoning** Coolant is toxic and a health hazard.

- Keep coolant out of the reach of children.
- Do not allow coolant to come into contact with the skin, the eyes and clothing.
- Consult a doctor immediately if coolant is swallowed.
- Rinse the affected area immediately with plenty of water in the event of contact with the skin.
- Rinse eyes thoroughly with water and consult a doctor immediately if coolant gets into the eyes.
- Change clothing if coolant spills onto your clothing.



### Info

Carry out this work with a cold engine.



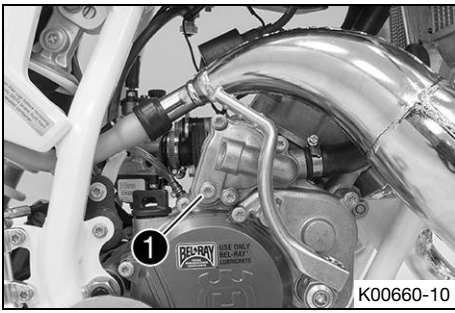

- Position the motorcycle upright.
- Place a suitable container under the water pump cover.
- Remove screw ①. Remove the radiator cap.
- Completely drain the coolant.
- Mount and tighten screw ① with a new seal ring.

**Guideline**

Drain plug, water pump cover	M6	6 Nm (4.4 lbf ft)
------------------------------	----	-------------------

## 14.5 Refilling with coolant

**Warning**

**Danger of poisoning** Coolant is toxic and a health hazard.

- Keep coolant out of the reach of children.
- Do not allow coolant to come into contact with the skin, the eyes and clothing.
- Consult a doctor immediately if coolant is swallowed.
- Rinse the affected area immediately with plenty of water in the event of contact with the skin.
- Rinse eyes thoroughly with water and consult a doctor immediately if coolant gets into the eyes.
- Change clothing if coolant spills onto your clothing.

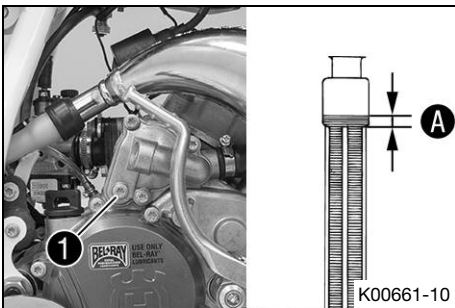

**Main work**

- Make sure that screw ① is tightened.
- Position the motorcycle upright.
- Add coolant to level ①.

**Guideline**

Distance ① above the radiator fins	10 mm (0.39 in)
Coolant	0.7 l (0.7 qt.) Coolant (📖 p. 87)

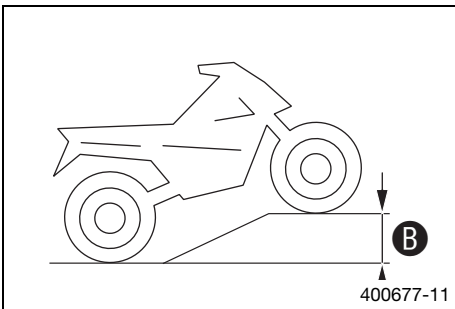

- Move the vehicle into the position shown and prevent it from rolling away. Height difference ② must be reached.

**Guideline**

Height difference ②	50 cm (19.7 in)
---------------------	-----------------

**i Info**

For all of the air to be able to escape from the cooling system, the vehicle must be raised at the front. If the cooling system is poorly de-aerated, its cooling power will be reduced and the engine may overheat.

- Return the vehicle to the horizontal position.
- Add coolant to level ①.
- Mount the radiator cap.

**Finishing work**

- Go for a short test ride.
- Check the cooling system for leaks.
- Check the coolant level. (📖 p. 70)

## 15.1 Checking the installation position of the throttle grip

**Warning**  
**Danger of accidents** The throttle cable may slip out of the guide if the throttle grip installation position is incorrect. The throttle slide will then no longer be closed and the speed can no longer be controlled.

- Make sure that installation position of the throttle grip complies with the specification.

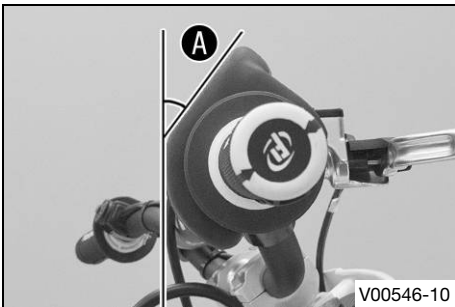

- Move the handlebar to the straight-ahead position.
- Check the installation position of the throttle grip.

Adjustment angle <b>A</b> , throttle grip	35°
---	-----

» If the adjustment angle does not meet specifications:

- Correct throttle grip installation position.

Guideline

Screw, throttle grip	M6	4.5 Nm (3.32 lbf ft)
----------------------	----	-------------------------

## 15.2 Checking the play in the throttle cable

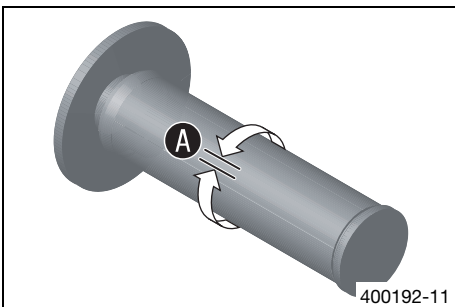

### Preparatory work

- Check the installation position of the throttle grip. (📖 p. 72)

### Main work

- Check the throttle grip for smooth operation.
- Move the handlebar to the straight-ahead position. Turn the throttle grip back and forth slightly and determine the play in throttle cable **A**.

Play in gas throttle cable	3... 5 mm (0.12... 0.2 in)
----------------------------	----------------------------

» If the throttle cable play does not meet the specified value:

- Adjust the play in the throttle cable. 🛠️ (📖 p. 72)



### Danger

**Danger of poisoning** Exhaust gases are toxic and inhaling them may result in unconsciousness and death.

- Always make sure there is sufficient ventilation when running the engine.
- Use an effective exhaust extraction system when starting or running the engine in an enclosed space.

- Start the engine and let it run idle. Move the handlebar to and fro over the entire steering range.

The idle speed must not change.
---------------------------------

» If the idle speed changes:

- Adjust the play in the throttle cable. 🛠️ (📖 p. 72)

## 15.3 Adjusting the play in the throttle cable 🛠️

### Preparatory work

- Check the installation position of the throttle grip. (📖 p. 72)
- Remove the seat. (📖 p. 42)
- Remove the left side cover. (📖 p. 39)
- Remove the right side cover. (📖 p. 38)
- Turn the knurled screw on the fuel tap all the way clockwise.
- Remove the fuel tank. 🛠️ (📖 p. 50)
- Check the throttle cable routing. (📖 p. 52)

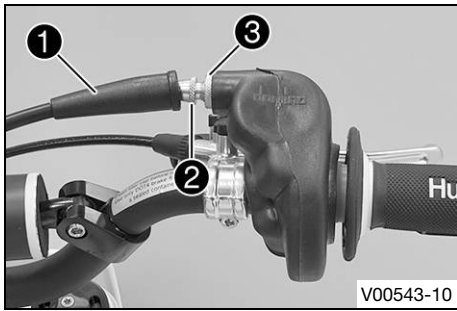

V00543-10

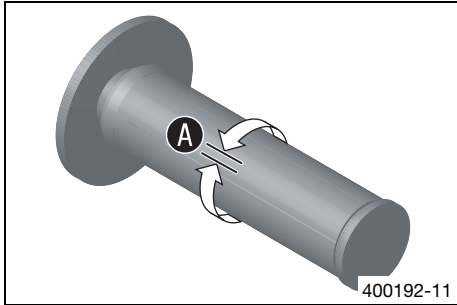

400192-11

### Main work

- Move the handlebar to the straight-ahead position.
- Push back sleeve ①.
- Ensure that the throttle cable sleeve is pushed all the way into barrel adjuster ②.
- Loosen nut ③.

- Turn barrel adjuster ② so that there is play A in the throttle cable at the throttle grip.

### Guideline

Play in gas throttle cable	3... 5 mm (0.12... 0.2 in)
----------------------------	----------------------------

- Tighten nut ③.
- Slide on sleeve ①.

### Finishing work

- Install the fuel tank. (🔧 p. 51)
- Install the left side cover. (🔧 p. 40)
- Install the right side cover. (🔧 p. 38)
- Mount the seat. (🔧 p. 43)
- Check the play in the throttle cable. (🔧 p. 72)

## 15.4 Carburetor - idle

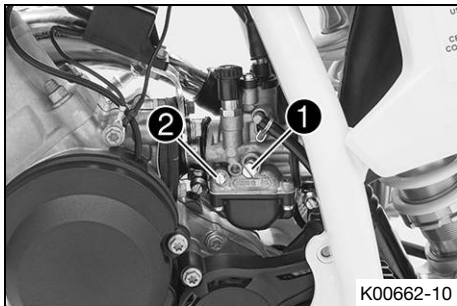

K00662-10

The idle setting of the carburetor has a big influence on the starting behavior, stable idling, and the response to throttle opening. This means that an engine with a correctly set idle speed is easier to start than if the idle speed is set wrongly.

### Info

The carburetor and its components are subject to increased wear caused by engine vibration. Wear can result in malfunctioning.

The idle speed is adjusted using the idle speed adjusting screw ①.  
The idle mixture is adjusted with the idle mixture adjusting screw ②.

## 15.5 Carburetor – adjusting the idle speed 🛠️

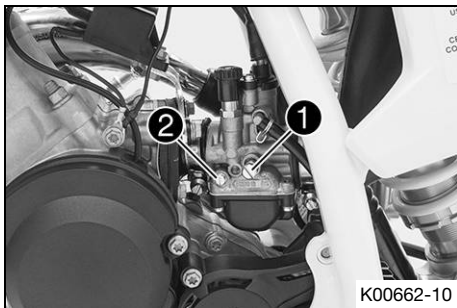

K00662-10

- Screw in idle adjusting screw ② until it stops and then to the prescribed basic setting.

### Guideline

Idle mixture adjusting screw	
Open	3 turns

- Run the engine until warm.

### Guideline

Warm-up time	≥ 5 min
--------------	---------

- Connect special tool.

Tachometer (45129075000)
--------------------------



### Danger

**Danger of poisoning** Exhaust gases are toxic and inhaling them may result in unconsciousness and death.

- Always make sure there is sufficient ventilation when running the engine.
- Use an effective exhaust extraction system when starting or running the engine in an enclosed space.

- Adjust the idle speed using idle speed adjusting screw ❶.

Guideline

Choke function deactivated – The choke lever is pushed in to the stop.  
(🗨 p. 12)

Idle speed	1,400... 1,500 rpm
------------	--------------------

- Turn idle mixture control screw ❷ slowly clockwise until the idle speed begins to fall.
- Note the position and turn the idle adjusting screw slowly counterclockwise until the idle speed falls again.
- Adjust to the point between these two positions with the highest idle speed.

**i Info**

If there is a big engine speed rise, reduce the idle speed to a normal level and repeat the above steps.

If the procedure described here does not lead to satisfactory results, the cause may be a wrongly dimensioned idling jet.

If you can turn the idle adjusting screw to the end without any change of engine speed, you have to fit a smaller idling jet.

After changing the idling jet, start from the beginning with the adjusting steps.

Following extreme air temperature or altitude changes, adjust the idle speed again.

## 15.6 Checking the clutch setting 🛠

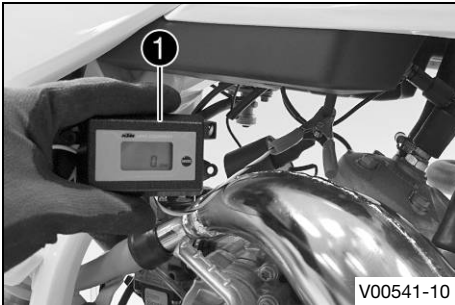

- Connect special tool ❶.

Tachometer (45129075000)
--------------------------

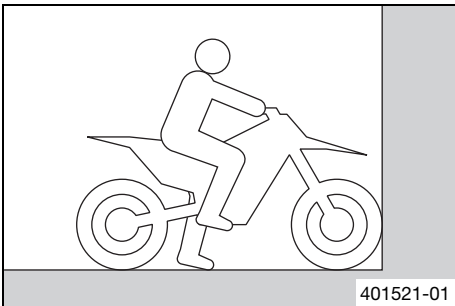

- Let the front wheel of the vehicle make contact with a fixed object.



**Danger**

**Danger of poisoning** Exhaust gases are toxic and inhaling them may result in unconsciousness and death.

- Always make sure there is sufficient ventilation when running the engine.
- Use an effective exhaust extraction system when starting or running the engine in an enclosed space.

- Start the motorcycle.
- Only ride full throttle to the point where the maximum engine speed is reached.

Guideline

≤ 3 s
-------

- Read the speed.

Slip speed	8,700... 9,300 rpm
------------	--------------------

- » If the specified value is not reached:
  - Adjust the clutch. 🛠 (🗨 p. 75)

## 15.7 Removing the clutch cover



### Warning

**Environmental hazard** Improper handling of fuel is a danger to the environment.

- Do not allow fuel to enter the groundwater, the soil, or the sewage system.



### Info

Fuel can emerge via the carburetor.  
Capture emerging fuel using a suitable container.



V00537-01

- Turn the knurled screw on the fuel tap all the way clockwise.
- Lay the vehicle down on its left side as shown.

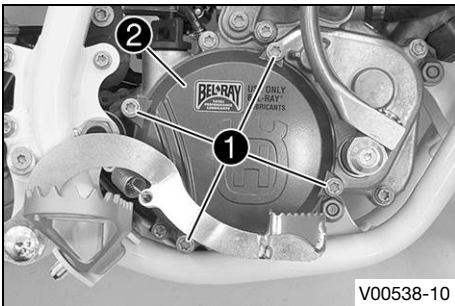

V00538-10

- Remove screws ①.
- Remove clutch cover ② with the seal ring.

## 15.8 Adjusting the clutch

### Preparatory work

- Remove the clutch cover. ↗ (p. 75)

### Main work

- Turn the outer clutch hub ① until adjusting screws ② become accessible.

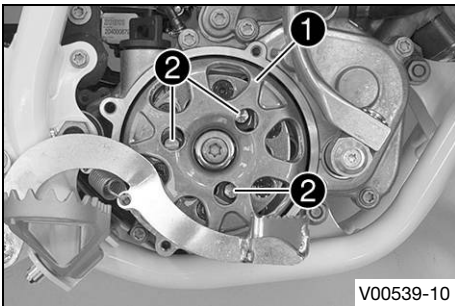

V00539-10

### Condition

If there is no reference point:

- Turn adjusting screws ② counterclockwise to the last detectable click.
- Turn adjusting screws ② clockwise by 9 clicks to the basic setting.

### Guideline

Basic setting of slip speed	8,700... 9,300 rpm
-----------------------------	--------------------

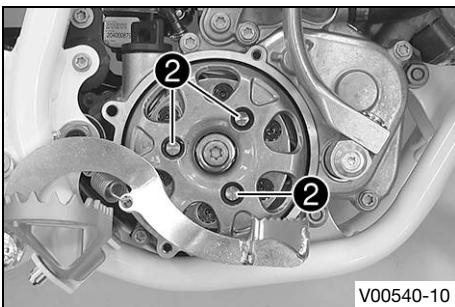

V00540-10



### Info

The springs may not be pretensioned by more than 17 clicks from the stop using the adjusting screws.

### Condition

If the slip speed is too low:

- Turn adjusting screws ② clockwise.

Guideline

1 click increases the slip speed by	250... 350 rpm
-------------------------------------	----------------

**i Info**

The springs may not be pretensioned by more than 17 clicks from the stop using the adjusting screws.

**Condition**

If the slip speed is too high:

- Turn adjusting screws ② counterclockwise.

Guideline

1 click decreases the slip speed by	250... 350 rpm
-------------------------------------	----------------

**Finishing work**

- Install the clutch cover. 🛠️ (p. 76)
- Check the gear oil level. 📖 (p. 77)
- Check the clutch setting. 🛠️ (p. 74)

## 15.9 Installing the clutch cover 🛠️

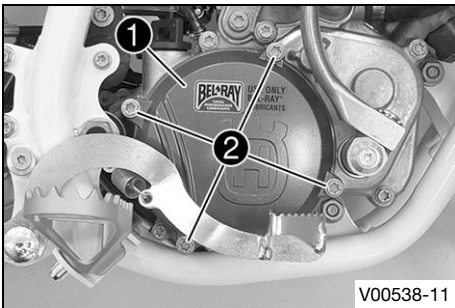

**Main work**

- Position clutch cover ① with the seal ring.
- Mount and tighten screws ②.

Guideline

Screw, clutch cover	M6	10 Nm (7.4 lbf ft)
---------------------	----	--------------------

**Finishing work**

- Check the gear oil level. 📖 (p. 77)

## 16.1 Checking the gear oil level

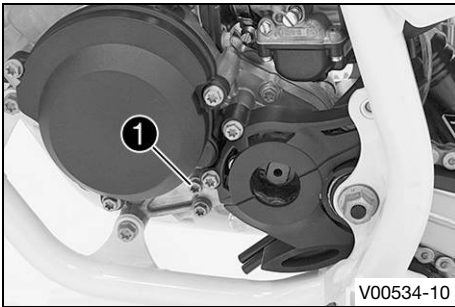

V00534-10

**Condition**

The engine is cold.

**Preparatory work**

- Stand the motorcycle upright on a horizontal surface.

**Main work**

- Remove screw ①.
- Check the gear oil level.

A small quantity of gear oil must run out of the drilled hole.

- » If no gear oil runs out:
  - Add gear oil. 🗣️ (p. 78)
- Mount and tighten screw ①.

**Guideline**

Screw, gear oil level check	M6	6 Nm (4.4 lbf ft)
-----------------------------	----	-------------------

## 16.2 Changing the gear oil 🗣️

**Warning**

**Danger of scalding** Engine and gear oil get very hot when the motorcycle is ridden.

- Wear suitable protective clothing and safety gloves.
- In the event of scalding, rinse the area affected immediately with lukewarm water.

**Warning**

**Environmental hazard** Hazardous substances cause environmental damage.

- Dispose of oils, grease, filters, fuel, cleaning agents, brake fluid, etc., correctly and in compliance with the applicable regulations.

**Info**

Drain gear oil with engine at operating temperature.

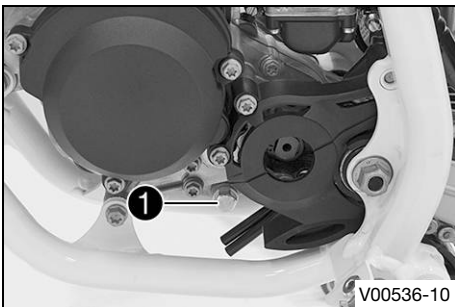

V00536-10

**Preparatory work**

- Stand the motorcycle on the plug-in stand on a horizontal surface.

**Main work**

- Place a suitable container under the engine.
- Remove oil drain plug ① with the magnet.
- Let the gear oil drain fully.
- Thoroughly clean the oil drain plug with magnet.
- Clean the sealing surface on the engine.
- Mount and tighten the oil drain plug with the magnet and a new seal ring.

**Guideline**

Oil drain plug with magnet	M12x1.5	20 Nm (14.8 lbf ft)
----------------------------	---------	---------------------

- Remove filler plug ② and fill up with gear oil.

Gear oil	0.20 l (0.21 qt.)	Gear oil (SAE 75W) 🗣️ (p. 87)
----------	-------------------	-------------------------------

**Info**

Too little gear oil or poor-quality gear oil results in premature wear to the transmission.

- Mount and tighten filler plug ②.

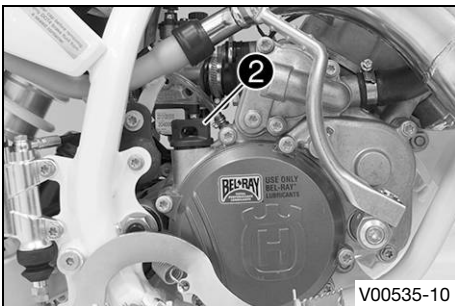

V00535-10



**Danger**

**Danger of poisoning** Exhaust gases are toxic and inhaling them may result in unconsciousness and death.

- Always make sure there is sufficient ventilation when running the engine.
- Use an effective exhaust extraction system when starting or running the engine in an enclosed space.

- Start the engine and check that it is oil-tight.

**Finishing work**

- Check the gear oil level. (📖 p. 77)

## 16.3 Adding gear oil 🛠️



**Info**

Too little gear oil or poor-quality gear oil results in premature wear to the transmission.

**Preparatory work**

- Stand the motorcycle upright on a horizontal surface.

**Main work**

- Remove screw ❶.

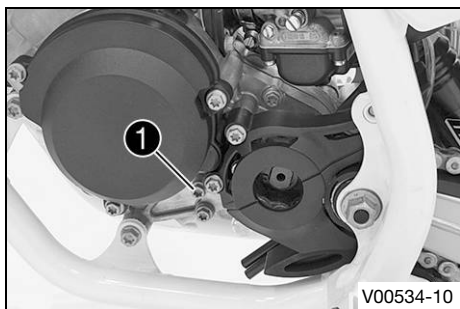

- Remove filler plug ❷.
- Add gear oil until it flows out of the hole of the gear oil level screw.

Gear oil (SAE 75W) (📖 p. 87)

- Mount and tighten screw ❶.

**Guideline**

Screw, gear oil level check	M6	6 Nm (4.4 lbf ft)
-----------------------------	----	-------------------

- Mount and tighten filler plug ❷.

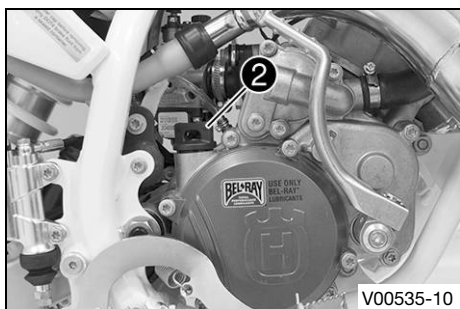

**Danger**

**Danger of poisoning** Exhaust gases are toxic and inhaling them may result in unconsciousness and death.

- Always make sure there is sufficient ventilation when running the engine.
- Use an effective exhaust extraction system when starting or running the engine in an enclosed space.

- Start the engine and check that it is oil-tight.



## 17.1 Cleaning the motorcycle

### Note

**Material damage** Components become damaged or destroyed if a pressure cleaner is used incorrectly. The high pressure forces water into the electrical components, connectors, throttle cables, and bearings, etc. Pressure which is too high causes malfunctions and destroys components.

- Do not direct the water jet directly on to electrical components, connectors, throttle cables or bearings.
- Maintain a minimum distance between the nozzle of the pressure cleaner and the component.  
Minimum clearance 60 cm (23.6 in)

### Warning

**Environmental hazard** Hazardous substances cause environmental damage.

- Dispose of oils, grease, filters, fuel, cleaning agents, brake fluid, etc., correctly and in compliance with the applicable regulations.

### Info

To maintain the value and appearance of the motorcycle over a long period, clean it regularly. Avoid direct sunshine when cleaning the motorcycle.

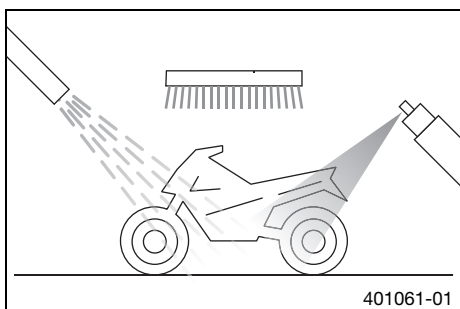

- Close off the exhaust system to keep water from entering.
- Remove loose dirt first with a soft jet of water.
- Spray dirty parts with a normal commercial engine cleaner and then brush off with a soft brush.

### Info

Use warm water containing normal motorcycle cleaner and a soft sponge. Never apply motorcycle cleaner to a dry vehicle; always rinse the vehicle with water first.

- After rinsing the motorcycle with a gentle spray of water, allow it to dry thoroughly.
- Remove the closure of the exhaust system.
- Empty the carburetor float chamber. 

### Warning

**Danger of accidents** Moisture and dirt impair the brake system.

- Explain to your child that he or she must brake carefully several times to dry out and remove dirt from the brake linings and the brake discs.

- After cleaning, let your child ride the vehicle a short distance until the engine warms up and the brakes have dried due to careful application of the brakes.

### Info

The heat produced causes water at inaccessible locations in the engine and on the brake system to evaporate.

- Push back the protection caps on the handlebar controls to allow water to evaporate.
- After the motorcycle has cooled off, lubricate all moving parts and bearings.
- Clean the chain.  p. 46
- Treat bare metal (except for brake discs and the exhaust system) with a corrosion inhibitor.
- Treat all plastic parts and powder-coated parts with a mild cleaning and care product.

## 18.1 Storage

### Warning

**Danger of poisoning** Fuel is poisonous and a health hazard.

- Avoid skin, eye and clothing contact with fuel.
- Immediately consult a doctor if you swallow fuel.
- Do not inhale fuel vapors.
- In case of skin contact, rinse the affected area with plenty of water.
- Rinse the eyes thoroughly with water, and consult a doctor in case of fuel contact with the eyes.
- Change your clothing in case of fuel spills on them.
- Keep fuels correctly in a suitable canister, and out of the reach of children.

### Info

If you plan to garage the motorcycle for a longer period, perform the following steps or have them performed. Before storing the motorcycle, check all parts for function and wear. If service, repairs, or replacements are necessary, you should do this during the storage period (less workshop overload). In this way, you can avoid long workshop waiting times at the start of the new season.

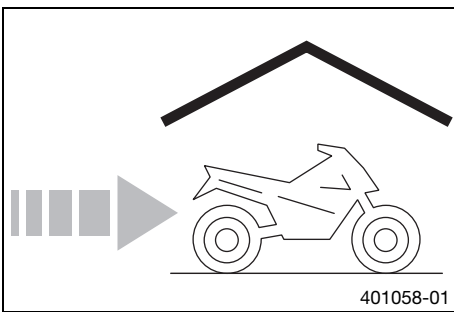

- When refueling for the last time before taking the motorcycle out of service, add fuel additive.
- Refuel. (📖 p. 18)
- Clean the motorcycle. (📖 p. 79)
- Change the gear oil. 🛠️ (📖 p. 77)
- Check the antifreeze and coolant level. (📖 p. 69)
- Empty the carburetor float chamber. 🛠️
- Check the tire air pressure. (📖 p. 68)
- Store the vehicle in a dry location that is not subject to large fluctuations in temperature.

### Info

Husqvarna Motorcycles recommends raising the motorcycle.

- Raise the motorcycle with a lift stand. (📖 p. 30)
- Cover the vehicle with a tarp or similar cover that is permeable to air.

### Info

Do not use non-porous materials since they prevent humidity from escaping, thus causing corrosion.

Avoid running the engine for a short time only. Because the engine will not warm up sufficiently, the water vapor produced during combustion will condense, causing engine parts and the exhaust system to rust.

## 18.2 Preparing for use after storage

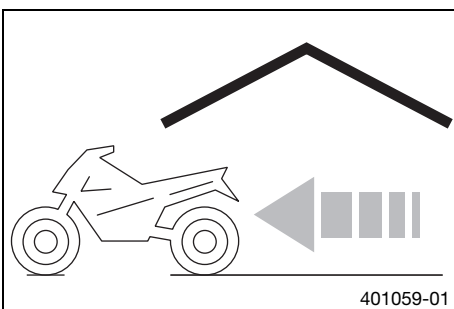

- Remove the motorcycle from the lift stand. (📖 p. 30)
- Perform checks and maintenance measures when preparing for use. (📖 p. 16)
- Take a test ride.

Faults	Possible cause	Action
Engine turns but does not start	Operating error	– Carry out the start procedure. (📖 p. 16)
	Motorcycle was out of use for a long time and there is old fuel in the float chamber	– Empty the carburetor float chamber. 🛠️
	Fuel supply interrupted	– Check the fuel tank breather. – Clean the fuel tap. – Check/set the carburetor components. 🛠️
	Spark plug oily or wet	– Clean and dry the spark plug, or change it if necessary.
	Electrode distance (plug gap) of spark plug too wide	– Adjust the plug gap. Guideline Spark plug electrode gap 0.60 mm (0.0236 in)
	Fault in ignition system	– Check the ignition system. 🛠️
	Short circuit cable in wiring harness frayed, kill switch defective	– Check the kill switch. 🛠️
	The connector or ignition coil is loose or oxidized	– Clean the plug-in connection and treat it with contact spray.
	Water in carburetor or jets blocked	– Check/set the carburetor components. 🛠️
Engine has no idle	Idling jet blocked	– Check/set the carburetor components. 🛠️
	Adjusting screws on the carburetor are in turned to the wrong position	– Carburetor – adjust the idle speed. 🛠️ (📖 p. 73)
	Spark plug defective	– Change spark plug.
	Ignition system defective	– Check the ignition coil. 🛠️ – Check the spark plug connector. 🛠️
Engine does not speed up	The carburetor is flowing over because the float needle is dirty or worn	– Check/set the carburetor components. 🛠️
	Loose carburetor jets	– Check/set the carburetor components. 🛠️
	Fault in ignition system	– Check the ignition system. 🛠️
Engine has too little power	Fuel supply interrupted	– Check the fuel tank breather. – Clean the fuel tap. – Check/set the carburetor components. 🛠️
	Air filter very dirty	– Clean the air filter and air filter box. 🛠️ (📖 p. 44)
	Exhaust system leaky, deformed or too little glass fiber yarn filling in main silencer	– Check exhaust system for damage. – Change the glass fiber yarn filling of the main silencer. 🛠️ (📖 p. 45)
	Ignition system defective	– Check the ignition coil. 🛠️ – Check the spark plug connector. 🛠️
	Diaphragm or reed valve housing damaged	– Check the diaphragm and reed valve housing.
	Noticeable wear	– Overhaul the engine.
	Clutch engagement speed too low or too high	– Check the clutch setting. 🛠️ (📖 p. 74)
Engine stalls or is popping into the carburetor	Lack of fuel	– Turn the knurled screw on the fuel tap all the way counterclockwise. – Refuel. (📖 p. 18)
	Engine takes in bad air	– Check the intake flange and carburetor for tightness.
	The connector or ignition coil is loose or oxidized	– Clean the plug-in connection and treat it with contact spray.
Engine overheats	Too little coolant in cooling system	– Check the cooling system for leakage. – Check the coolant level. (📖 p. 70)
	Too little air stream	– Switch off engine when standing.

Faults	Possible cause	Action
Engine overheats	Radiator fins very dirty	– Clean radiator fins.
	Foam formation in cooling system	– Drain the coolant. 🛠️ (📖 p. 70) – Refill with coolant. 🛠️ (📖 p. 71)
	Damaged cylinder head or cylinder head gasket	– Check the cylinder head or cylinder head gasket.
	Bent radiator hose	– Change the radiator hose. 🛠️
White smoke emission (steam in exhaust gas)	Damaged cylinder head or cylinder head gasket	– Check the cylinder head or cylinder head gasket.
Gear oil exits at the vent hose	Too much gear oil added	– Check the gear oil level. (📖 p. 77)
Water in the gear oil	Damaged shaft seal ring or water pump	– Check the shaft seal ring and water pump.

## 20.1 Engine

Design	1-cylinder 2-stroke engine, water-cooled, with reed intake
Displacement	49.0 cm <sup>3</sup> (2.99 cu in)
Stroke	40 mm (1.57 in)
Bore	39.5 mm (1.555 in)
Crankshaft bearing	2 grooved ball bearings
Conrod bearing	Needle bearing
Piston pin bearing	Needle bearing
Pistons	Aluminum cast
Piston rings	1 rectangular ring
Engine lubrication	Mixture oil lubrication
Primary transmission	33:61 straight cut spur gear
Clutch	Multi-disc automatic clutch on the main shaft/centrifugal force
Gearbox	Rigid 1-stage reduction gear
Transmission ratio	14:31
Ignition	SELETTTRA 2p D36
Spark plug	NGK LR 8 B
Spark plug electrode gap	0.60 mm (0.0236 in)
Cooling	Water-cooled
Starting aid	Kickstarter

## 20.2 Engine tightening torques

Screw, bearing retainer	M5	5 Nm (3.7 lbf ft)	–
Screw, kickstarter	M5	6 Nm (4.4 lbf ft)	<b>Loctite® 243™</b>
Screw, stator clamp	M5	6 Nm (4.4 lbf ft)	<b>Loctite® 222™</b>
Screw, water pump wheel	M5	5 Nm (3.7 lbf ft)	<b>Loctite® 243™</b>
Bleeder flange of engine case	M6	4 Nm (3 lbf ft)	<b>Loctite® 243™</b>
Drain plug, water pump cover	M6	6 Nm (4.4 lbf ft)	–
Screw, alternator cover	M6	6 Nm (4.4 lbf ft)	–
Screw, clutch cover	M6	10 Nm (7.4 lbf ft)	–
Screw, engine case	M6	10 Nm (7.4 lbf ft)	–
Screw, engine sprocket cover	M6	10 Nm (7.4 lbf ft)	–
Screw, exhaust flange	M6	10 Nm (7.4 lbf ft)	<b>Loctite® 243™</b>
Screw, fitting pin	M6	10 Nm (7.4 lbf ft)	<b>Loctite® 648™</b>
Screw, gear oil level check	M6	6 Nm (4.4 lbf ft)	–
Screw, ignition coil	M6	4 Nm (3 lbf ft)	<b>Loctite® 243™</b>
Screw, intake flange	M6	5 Nm (3.7 lbf ft)	<b>Loctite® 243™</b>
Screw, pressure plate	M6	10 Nm (7.4 lbf ft)	<b>Loctite® 243™</b>
Screw, water pump cover	M6	10 Nm (7.4 lbf ft)	–
Screw, cylinder head	M7	18 Nm (13.3 lbf ft)	–
Nuts, cylinder base	M8	20 Nm (14.8 lbf ft)	–
Screw, outer clutch hub	M8	35 Nm (25.8 lbf ft)	<b>Loctite® 243™</b>
Stud bolt, cylinder base	M8	10 Nm (7.4 lbf ft)	–
Spark plug	M10x1	10... 12 Nm (7.4... 8.9 lbf ft)	–
Nut, primary gear	M10x1.25	40 Nm (29.5 lbf ft)	<b>Loctite® 243™</b>
Nut, rotor	M10x1.25	15 Nm (11.1 lbf ft)	<b>Loctite® 243™</b>
Oil drain plug with magnet	M12x1.5	20 Nm (14.8 lbf ft)	–

## 20.3 Carburetor with carburetor tuning

Carburetor type	Dell'Orto PHBG 19BS
Needle position	2nd position from top
Idle mixture adjusting screw	
Open	3 turns
Main jet	95
Jet needle	W7
Idling jet	50
Needle jet	262AU
Throttle slide	40
Cold start jet	60

## 20.4 Capacities

### 20.4.1 Gear oil

Gear oil	0.20 l (0.21 qt.)	Gear oil (SAE 75W) (📖 p. 87)
----------	-------------------	------------------------------

### 20.4.2 Coolant

Coolant	0.7 l (0.7 qt.)	Coolant (📖 p. 87)
---------	-----------------	-------------------

### 20.4.3 Fuel

Fuel tank capacity, approx.	2.3 l (2.4 qt.)	Super unleaded (95 octane) mixed with 2-stroke engine oil (1:60) (📖 p. 88)
-----------------------------	-----------------	--

## 20.5 Chassis

Frame	Central tube frame of chrome molybdenum steel tubing, powder-coated	
Fork	<b>WP Performance Systems</b> Upside down <b>AER 35</b>	
Shock absorber	<b>WP Performance Systems</b> 3614 DCC	
Suspension travel		
Front	205 mm (8.07 in)	
Rear	185 mm (7.28 in)	
Fork offset	22 mm (0.87 in)	
Brake system		
Front	Disc brake with four-pot brake caliper	
Rear	Disc brake with two-pot brake caliper	
Brake disc diameters		
Front	160 mm (6.3 in)	
Rear	160 mm (6.3 in)	
Brake discs - wear limits		
Front	2.2 mm (0.087 in)	
Rear	2.2 mm (0.087 in)	
Tire air pressure off road		
Front	1.0 bar (15 psi)	
Rear	1.0 bar (15 psi)	
Secondary drive ratio	11:40	
Chain	1/2 x 3/16"	
Rear sprockets available	38, 39, 40, 41, 42	
Steering head angle	66°	
Wheelbase	1,032±10 mm (40.63±0.39 in)	
Seat height unloaded	684 mm (26.93 in)	

Ground clearance unloaded	252 mm (9.92 in)
Weight without fuel, approx.	41.5 kg (91.5 lb.)

## 20.6 Tires

Front tires	Rear tires
<b>60/100 - 12 36M TT</b> MAXXIS MAXX CROSS SI	<b>2.75 - 10 38J TT</b> MAXXIS MAXX CROSS SI
The tires specified represent one of the possible series production tires. Additional information is available in the Service section under: <a href="http://www.husqvarna-motorcycles.com">www.husqvarna-motorcycles.com</a>	

## 20.7 Fork

Fork part number	07.18.6Q.02	
Fork	<b>WP Performance Systems Upside down AER 35</b>	
Rebound damping		
Comfort	15 clicks	
Standard	12 clicks	
Sport	10 clicks	
Air pressure	2 bar (29 psi)	
Fork length	685 mm (26.97 in)	
Oil capacity external mechanism left	25±5 ml (0.85±0.17 fl. oz.)	Fork oil (SAE 4) (48601166S1) (📖 p. 87)
Oil capacity, right cartridge	240 ml (8.11 fl. oz.)	Fork oil (SAE 4) (48601166S1) (📖 p. 87)
Grease capacity, left cartridge	6 ml (0.2 fl. oz.)	Multi-purpose grease (00062010051) (📖 p. 89)

## 20.8 Shock absorber

Shock absorber article number	03.18.7Q.02	
Shock absorber	<b>WP Performance Systems 3614 DCC</b>	
Compression damping, low-speed		
Comfort	18 clicks	
Standard	15 clicks	
Sport	12 clicks	
Compression damping, high-speed		
Comfort	2.5 turns	
Standard	2 turns	
Sport	1.5 turns	
Rebound damping		
Comfort	17 clicks	
Standard	15 clicks	
Sport	13 clicks	
Spring preload		
Standard	3 mm (0.12 in)	
Spring rate		
Weight of rider: 15... 25 kg (33... 55 lb.)	30 N/mm (171 lb/in)	
Weight of rider (standard): 25... 35 kg (55... 77 lb.)	35 N/mm (200 lb/in)	
Weight of rider: 35... 45 kg (77... 99 lb.)	40 N/mm (228 lb/in)	
Spring length	130 mm (5.12 in)	
Gas pressure	10 bar (145 psi)	
Static sag	12 mm (0.47 in)	
Riding sag	80 mm (3.15 in)	
Fitted length	275 mm (10.83 in)	

Shock absorber oil	Shock absorber fluid (SAE 2.5) (50180751S1) (📖 p. 88)
--------------------	---

## 20.9 Chassis tightening torques

Screw, side cover	EJOT PT® K60x20-Z	2 Nm (1.5 lbf ft)	–
Spoke nipple	M3.5	3 Nm (2.2 lbf ft)	–
Screw, brake line bracket	M5	2 Nm (1.5 lbf ft)	–
Screw, brake linings	M5	8 Nm (5.9 lbf ft)	–
Nut, push rod ball joint on foot brake cylinder	M6	10 Nm (7.4 lbf ft)	–
Rear brake caliper screw	M6	10 Nm (7.4 lbf ft)	Loctite® 243™
Remaining nuts, chassis	M6	10 Nm (7.4 lbf ft)	–
Remaining screws, chassis	M6	10 Nm (7.4 lbf ft)	–
Screw, chain sliding piece	M6	3 Nm (2.2 lbf ft)	–
Screw, fender	M6	6 Nm (4.4 lbf ft)	–
Screw, fork stub	M6	10 Nm (7.4 lbf ft)	–
Screw, front brake disc	M6	14 Nm (10.3 lbf ft)	Loctite® 243™
Screw, rear brake disc	M6	14 Nm (10.3 lbf ft)	Loctite® 243™
Screw, start number plate	M6	4 Nm (3 lbf ft)	–
Screw, throttle grip	M6	4.5 Nm (3.32 lbf ft)	–
Nut, foot brake lever	M8	22 Nm (16.2 lbf ft)	–
Nut, rim lock	M8	10 Nm (7.4 lbf ft)	–
Remaining nuts, chassis	M8	25 Nm (18.4 lbf ft)	–
Remaining screws, chassis	M8	25 Nm (18.4 lbf ft)	–
Screw, bottom triple clamp	M8	15 Nm (11.1 lbf ft)	–
Screw, chain sliding piece	M8	15 Nm (11.1 lbf ft)	–
Screw, engine bracket	M8	25 Nm (18.4 lbf ft)	Loctite® 243™
Screw, front brake caliper	M8	20 Nm (14.8 lbf ft)	Loctite® 243™
Screw, handlebar clamp	M8	20 Nm (14.8 lbf ft)	–
Screw, rear sprocket	M8	25 Nm (18.4 lbf ft)	Loctite® 243™
Screw, top triple clamp	M8	20 Nm (14.8 lbf ft)	–
Nut, swingarm pivot	M10	45 Nm (33.2 lbf ft)	–
Remaining nuts, chassis	M10	45 Nm (33.2 lbf ft)	–
Remaining screws, chassis	M10	45 Nm (33.2 lbf ft)	–
Screw, bottom shock absorber	M10	45 Nm (33.2 lbf ft)	Loctite® 243™
Screw, front wheel spindle	M10	40 Nm (29.5 lbf ft)	Loctite® 243™
Screw, handlebar support	M10	40 Nm (29.5 lbf ft)	Loctite® 243™
Screw, top shock absorber	M10	45 Nm (33.2 lbf ft)	Loctite® 243™
Nut, rear wheel spindle	M12x1	40 Nm (29.5 lbf ft)	–
Nut, steering head	M20x1.5	10 Nm (7.4 lbf ft)	–
Nut, steering head	M20x1.5	9 Nm (6.6 lbf ft)	Only applies when using: Holding wrench for steering head bearing (45229050000)



## Brake fluid DOT 4

### Standard/classification

- DOT

### Guideline

- Use only brake fluid that complies with the specified standard (see specifications on the container) and that possesses the corresponding properties.

### Recommended supplier

#### Bel-Ray®

- Super DOT 4 Brake Fluid

## Coolant

### Guideline

- Only use high-grade, silicate-free coolant with corrosion inhibitor additive for aluminum motors. Low grade and unsuitable antifreeze causes corrosion, deposits and frothing.
- Do not use pure water as only coolant is able to meet the requirements needed in terms of corrosion protection and lubrication properties.
- Only use coolant that complies with the requirements stated (see specifications on the container) and that has the relevant properties.

Antifreeze protection to at least	-25 °C (-13 °F)
-----------------------------------	-----------------

The mixture ratio must be adjusted to the necessary antifreeze protection. Use distilled water if the coolant needs to be diluted.

The use of premixed coolant is recommended.

Observe the coolant manufacturer specifications for antifreeze protection, dilution and miscibility (compatibility) with other coolants.

### Recommended supplier

#### Bel-Ray®

- Moto Chill Racing Coolant

## Engine oil, 2-stroke

### Standard/classification

- JASO FD (📖 p. 90)

### Guideline

- Only use high grade 2-stroke engine oil of a reputable brand.

Synthetic engine oil
----------------------

### Recommended supplier

#### Bel-Ray®

- Si-7 Synthetic 2T

## Fork oil (SAE 4) (48601166S1)

### Standard/classification

- SAE (📖 p. 90) (SAE 4)

### Guideline

- Use only oils that comply with the specified standards (see specifications on the container) and that exhibit the corresponding properties.

## Gear oil (SAE 75W)

### Standard/classification

- SAE (📖 p. 90) (SAE 75W)

### Guideline

- Use only gear oils that comply with the specified standards (see specifications on the container) and that exhibit the required properties.

### Recommended supplier

#### Bel-Ray®

- Gear Saver

## Shock absorber fluid (SAE 2.5) (50180751S1)

### Standard/classification

- SAE (📖 p. 90) (SAE 2.5)

### Guideline

- Use only oils that comply with the specified standards (see specifications on the container) and that exhibit the corresponding properties.

## Super unleaded (ROZ 95/RON 95/PON 91)

### Standard/classification

- DIN EN 228 (ROZ 95/RON 95/PON 91)

### Guideline

- Only use unleaded super fuel that matches or is equivalent to the specified fuel grade.
- Fuel with an ethanol content of up to 10 % (E10 fuel) is safe to use.



### Info

Do **not** use fuel containing methanol (e. g. M15, M85, M100) or more than 10 % ethanol (e. g. E15, E25, E85, E100).

## Super unleaded (95 octane) mixed with 2-stroke engine oil (1:60)

### Standard/classification

- DIN EN 228
- JASO FD (📖 p. 90) (1:60)

### Mixture ratio

1:60	Engine oil, 2-stroke (📖 p. 87) Super unleaded (ROZ 95/RON 95/PON 91) (📖 p. 88)
------	---

### Recommended supplier

#### Bel-Ray®

- Si-7 Synthetic 2T

## Air filter cleaning agent

Recommended supplier

Bel-Ray®

- Foam Filter Cleaner & Degreaser

## Grip adhesive (00062030051)

Recommended supplier

KTM AG

- GRIP GLUE

## High viscosity grease

Recommended supplier

SKF®

- LGHB 2

## Long-life grease

Recommended supplier

Bel-Ray®

- Waterproof Grease

## Multi-purpose grease (00062010051)

Recommended supplier

Klüber Lubrication®

- CENTOPLEX 2 EP

## Offroad chain spray

Guideline

Recommended supplier

Bel-Ray®

- Blue Tac Chain Lube

## Oil for foam air filter

Recommended supplier

Bel-Ray®

- Foam Filter Oil

## Universal oil spray

Recommended supplier

Bel-Ray®

- 6 in 1

### JASO FD

JASO FD is a classification for a 2-stroke engine oil that was specifically developed for the extreme demands of racing. Thanks to first rate synthetic esters and specially designed additives, superb combustion is achieved even under extreme operating conditions.

### SAE

The SAE viscosity classes were defined by the Society of Automotive Engineers and are used for classifying oils according to their viscosity. The viscosity describes only one property of oil and says nothing about quality.

## 24 LIST OF ABBREVIATIONS

Art. no.	Article number
ca.	circa
cf.	compare
e.g.	for example
etc.	et cetera
i.a.	inter alia
no.	number
poss.	possibly

<b>A</b>	
<b>Accessories</b>	7
<b>Air filter</b>	
cleaning	44
installing	43
removing	43
<b>Air filter box</b>	
cleaning	44
<b>Air suspension AER 35</b>	
	22
<b>Antifreeze</b>	
checking	69
<b>Auxiliary substances</b>	
	7
<b>B</b>	
<b>Basic chassis setting</b>	
checking with rider's weight	22
<b>Brake discs</b>	
checking	55
<b>Brake fluid</b>	
of front brake, adding	56
of rear brake, adding	61
<b>Brake fluid level</b>	
front brake, checking	55
rear brake, checking	61
<b>Brake linings</b>	
front brake, checking	57
of front brake, changing	57
rear brake, changing	62
rear brake, checking	62
<b>C</b>	
<b>Capacity</b>	
coolant	71, 84
fuel	19, 84
gear oil	77, 84
<b>Carburetor</b>	
idle	73
idle speed, adjusting	73
<b>Chain</b>	
checking	48
cleaning	46
<b>Chain guide</b>	
adjusting	50
checking	48
<b>Chain tension</b>	
adjusting	47
checking	47
<b>Chassis number</b>	
	10
<b>Choke</b>	
	12
<b>Cleaning</b>	
	79
<b>Clutch</b>	
adjusting	75
setting, checking	74
<b>Clutch cover</b>	
clutch cover, removing	75

installing the clutch cover	76
<b>Compression damping, low-speed</b>	
shock absorber, adjusting	23
<b>Coolant</b>	
draining	70
refilling	71
<b>Coolant level</b>	
checking	69-70
<b>Cooling system</b>	
	69
<b>Customer service</b>	
	7
<b>D</b>	
<b>Dust boots</b>	
cleaning	31
<b>E</b>	
<b>Engine</b>	
running in	15
<b>Engine number</b>	
	10
<b>Engine sprocket</b>	
checking	48
<b>Engine sprocket cover</b>	
installing	46
removing	46
<b>Environment</b>	
	6
<b>F</b>	
<b>Figures</b>	
	7
<b>Filler cap</b>	
closing	12
opening	11
<b>Foot brake lever</b>	
basic position, adjusting	60
free travel, adjusting	60
free travel, checking	59
<b>Fork legs</b>	
air pressure, adjusting	26
basic setting, checking	26
bleeding	30
installing	32
removing	32
<b>Fork part number</b>	
	10
<b>Fork protector</b>	
installing	31
removing	31
<b>Frame</b>	
checking	50
<b>Front fender</b>	
installing	37
removing	37
<b>Front wheel</b>	
installing	65
removing	65
<b>Fuel tank</b>	
installing	51
removing	50

**Fuel tap** ..... 12

**G**

**Gear oil**  
 adding ..... 78  
 changing ..... 77

**Gear oil level**  
 checking ..... 77

**H**

**Hand brake lever** ..... 11  
 basic position, adjusting ..... 54  
 checking play ..... 54  
 play, adjusting ..... 54

**Handlebar position** ..... 28  
 adjusting ..... 28

**High Speed compression damping**  
 shock absorber, adjusting ..... 23

**I**

**Implied warranty** ..... 7  
**Intended use** ..... 5

**K**

**Kick starter** ..... 13  
**Kill switch** ..... 11

**L**

**Lower triple clamp**  
 installing ..... 34  
 removing ..... 33

**M**

**Main silencer**  
 glass fiber yarn filling, changing ..... 45  
 installing ..... 45  
 removing ..... 44

**Motorcycle**  
 cleaning ..... 79  
 lift stand, raising with ..... 30  
 lift stand, removing from ..... 30

**O**

**Operating substances** ..... 7  
**Owner's Manual** ..... 6

**P**

**Play in throttle cable**  
 checking ..... 72

**Plug-in stand** ..... 13

**Preparing for use**  
 advice on first use ..... 14  
 after storage ..... 80  
 checks and maintenance measures when preparing for use ..... 16

**Protective clothing** ..... 6

**R**

**Rear sprocket**  
 checking ..... 48

**Rear wheel**  
 installing ..... 66  
 removing ..... 66

**Rebound damping**  
 fork, adjusting ..... 27  
 shock absorber, adjusting ..... 24

**Refueling**  
 fuel ..... 18

**Riding sag**  
 adjusting ..... 26

**Right side cover**  
 installing ..... 38  
 removing ..... 38  
 securing ..... 39

**Rubber grip**  
 checking ..... 53  
 securing ..... 53

**S**

**Safe operation** ..... 5

**Seat**  
 mounting ..... 43  
 removing ..... 42

**Seat height**  
 adjusting ..... 28

**Service** ..... 7

**Service hour counter** ..... 13

**Service schedule** ..... 20-21

**Shock absorber**  
 installing ..... 42  
 removing ..... 41  
 riding sag, checking ..... 25  
 spring preload, adjusting ..... 25  
 static sag, checking ..... 24

**Shock absorber article number** ..... 10

**Side cover, left**  
 installing ..... 40  
 removing ..... 39  
 securing ..... 41

**Spare parts** ..... 7

**Spoke tension**  
 checking ..... 68

**Start number plate**  
 installing ..... 37  
 removing ..... 36

**Starting** ..... 16

**Steering head bearing**  
 greasing ..... 36

**Steering head bearing play**  
 adjusting ..... 36  
 checking ..... 35

**Storage** ..... 80

**Swingarm**  
 checking ..... 50

## T

### Technical data

capacities	84
carburetor	84
chassis	84
chassis tightening torques	86
engine	83
engine tightening torques	83
fork	85
shock absorber	85
tires	85

### Throttle cable play

adjusting	72
-----------	----

### Throttle cable routing

checking	52
----------	----

### Throttle grip

	11
--	----

### Tire air pressure

checking	68
----------	----

### Tire condition

checking	67
----------	----

### Transport

	18
--	----

### Troubleshooting

	81-82
--	-------

### Type label

	10
--	----

## U

### Use definition

	5
--	---

## V

### View of vehicle

front left	8
rear right	9

## W

### Warranty

	7
--	---

### Work rules

	6
--	---



PIONEERING SINCE 1903



3402091en

09/2016



**Husqvarna**<sup>®</sup>  
MOTORCYCLES

Husqvarna Motorcycles GmbH  
Stallhofnerstraße 3 | 5230 Mattighofen | Austria  
[www.husqvarna-motorcycles.com](http://www.husqvarna-motorcycles.com)



Photo: Mitterbauer,  
Husqvarna Motorcycles GmbH